



- (51) International Patent Classification:
B60N 2/48 (2006.01)
- (21) International Application Number:
PCT/US2013/051554
- (22) International Filing Date:
23 July 2013 (23.07.2013)
- (25) Filing Language: English
- (26) Publication Language: English
- (30) Priority Data:
61/675,048 24 July 2012 (24.07.2012) US
- (71) Applicant: TOYOTA BOSHOKU AMERICA, INC.
[US/US]; 28000 West Park Drive, Novi, MI 48377 (US).
- (72) Inventors: RONZI, Brett; 3096 Donna Drive, Highland,
MI 48357 (US). ISAACSON, Troy, Allen; 1294 Briar-
wood Ct., Wixom, MI 48393 (US).
- (74) Agent: BUTCHKO, Karin, H.; Carlson, Gaskey & Olds,
P.C., 400 West Maple Road, Suite 350, Birmingham, MI
48009 (US).

- (81) Designated States (unless otherwise indicated, for every kind of national protection available): AE, AG, AL, AM, AO, AT, AU, AZ, BA, BB, BG, BH, BN, BR, BW, BY, BZ, CA, CH, CL, CN, CO, CR, CU, CZ, DE, DK, DM, DO, DZ, EC, EE, EG, ES, FI, GB, GD, GE, GH, GM, GT, HN, HR, HU, ID, IL, IN, IS, JP, KE, KG, KN, KP, KR, KZ, LA, LC, LK, LR, LS, LT, LU, LY, MA, MD, ME, MG, MK, MN, MW, MX, MY, MZ, NA, NG, NI, NO, NZ, OM, PA, PE, PG, PH, PL, PT, QA, RO, RS, RU, RW, SC, SD, SE, SG, SK, SL, SM, ST, SV, SY, TH, TJ, TM, TN, TR, TT, TZ, UA, UG, US, UZ, VC, VN, ZA, ZM, ZW.
- (84) Designated States (unless otherwise indicated, for every kind of regional protection available): ARIPO (BW, GH, GM, KE, LR, LS, MW, MZ, NA, RW, SD, SL, SZ, TZ, UG, ZM, ZW), Eurasian (AM, AZ, BY, KG, KZ, RU, TJ, TM), European (AL, AT, BE, BG, CH, CY, CZ, DE, DK, EE, ES, FI, FR, GB, GR, HR, HU, IE, IS, IT, LT, LU, LV, MC, MK, MT, NL, NO, PL, PT, RO, RS, SE, SI, SK, SM, TR), OAPI (BF, BJ, CF, CG, CI, CM, GA, GN, GQ, GW, KM, ML, MR, NE, SN, TD, TG).

Published:
— with international search report (Art. 21(3))

[Continued on next page]

(54) Title: HEADREST ADJUSTMENT MECHANISM FOR VEHICLE SEATS

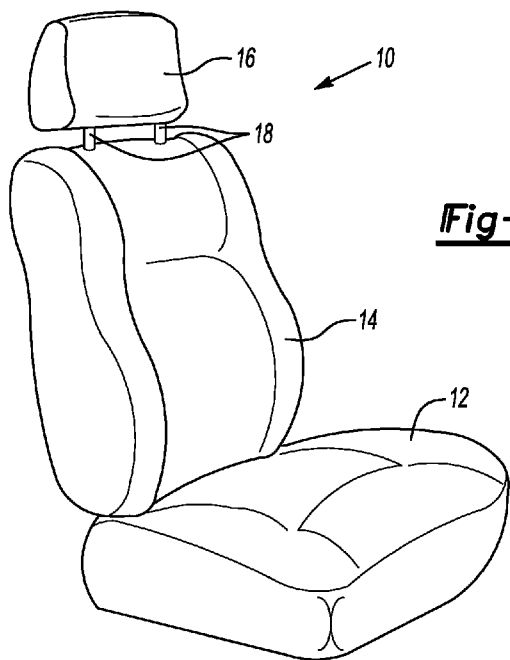

Fig-1

(57) Abstract: A bushing allows for adjustability of a position of a headrest. The bushing includes a head portion having an opening and a passageway opening. The bushing also includes a body portion defining an internal passageway. The passageway opening of the head portion is aligned with the internal passageway of the body portion. The body portion includes a wall surrounding an area of reduced thickness, and a protrusion is located on an internal surface of the area of reduced thickness. The bushing also includes a moveable portion received in the opening of the head portion. The moveable portion is moveable between a first position where a feature engages a notch of a post receivable in the internal passageway of the body portion and the passageway opening of the head portion to retain the headrest in a position and a second position where the feature is disengaged from the notch of the post, allowing the post and the headrest to move relative to the bushing.

WO 2014/018471 A1

- *before the expiration of the time limit for amending the claims and to be republished in the event of receipt of amendments (Rule 48.2(h))*

HEADREST ADJUSTMENT MECHANISM FOR VEHICLE SEATS

REFERENCE TO RELATED APPLICATIONS

[0001] The application claims priority to United States Provisional Application No. 61/675,048 filed on July 24, 2012.

BACKGROUND OF THE INVENTION

[0002] A vehicle seat can include an adjustable headrest mounted to a backrest of the vehicle seat. The headrest can be moved in a generally vertical direction relative to the seat. Two posts are mounted to the headrest. Two guide sleeves are located within the backrest of the vehicle seat, and a bushing is received in each of the two guide sleeves. Each post is receivable in one of the two guide sleeves.

[0003] Each post includes a plurality of notches. One bushing includes a mechanism that is received in one of the notches, securing the post and the attached headrest in a position. When the headrest is to be moved to another position relative to the backrest of the vehicle seat, the mechanism of the bushing is removed from the notch of the post, allowing the post, and therefore the attached headrest, to slide in the generally vertical direction relative to the backrest of the vehicle seat to a desired position. Once the headrest is in the desired position, the mechanism is released to allow the mechanism to engage another notch of the post, securing the headrest in the desired position.

SUMMARY OF THE INVENTION

[0004] A bushing allows for adjustability of a position of a headrest. The bushing includes a head portion having an opening and a passageway opening. The bushing also includes a body portion defining an internal passageway. The passageway opening of the head portion is aligned with the internal passageway of the body portion. The body portion includes a wall surrounding an area of reduced thickness, and a protrusion is located on an internal surface of the area of reduced thickness. The bushing also includes a moveable portion received in the opening of the head portion. The moveable portion is moveable between a first position where a feature

engages a notch of a post receivable in the internal passageway of the body portion and the passageway opening of the head portion to retain the headrest in a position and a second position where the feature is disengaged from the notch of the post, allowing the post and the headrest to move relative to the bushing.

[0005] A headrest assembly includes a headrest, two posts secured to the headrest, where at least one of the two posts includes a plurality of notches, and a bushing to allow adjustability of a position of the headrest. The bushing includes a head portion having an opening and a passageway opening. The bushing also includes a body portion defining an internal passageway, where the passageway opening of the head portion is aligned with the internal passageway of the body portion. The body portion includes a wall surrounding two areas having a reduced thickness on opposing sides of the body portion, and a protrusion is located on an internal surface of each of the two areas of reduced thickness. A first distance is defined between the internal surfaces of the two areas of reduced thickness, a second distance is defined between the two projections, and the second distance is less than the first distance. One of the two posts with the plurality of notches is received in the internal passageway of the body portion and the passageway opening of the head portion of the bushing and has a third diameter that is greater than the second distance defined between the two projections. The bushing also includes a moveable portion received in the opening of the head portion. The moveable portion is moveable between a first position where a feature engages one of the plurality of notches of the post receivable in the internal passageway of the body portion and the passageway opening of the head portion of the bushing to retain the headrest in a position and a second position where the feature is disengaged from the one of the plurality of notches of the post, allowing the post and the headrest to move relative to the bushing.

[0006] These and other features of the present invention can be best understood from the following specification and drawings, the following of which is a brief description.

BRIEF DESCRIPTION OF THE DRAWINGS

[0007] Figure 1 illustrates a perspective view of a vehicle seat and a headrest adjustment mechanism;

[0008] Figure 2 illustrates a view of a top portion of a backrest of a vehicle seat, the headrest, and an adjustment mechanism;

[0009] Figure 3 illustrates a perspective view of a bushing;

[0010] Figure 4 illustrates a cross sectional view of a moveable portion received within an opening of a head portion of the bushing when a metal piece engages a notch in a post to retain the headrest in a first position;

[0011] Figure 5 illustrates a cross sectional view of the moveable portion received within the opening of the head portion of the bushing when the metal piece does not engage the notch in the post to allow the post and the headrest to move relative to the backrest;

[0012] Figure 6 illustrates another perspective view of the bushing;

[0013] Figure 7 illustrates a side view of the moveable portion;

[0014] Figure 8 illustrates a front view of the moveable portion;

[0015] Figure 9 illustrates a front view of the bushing;

[0016] Figure 10 illustrates a cross-sectional view of the body portion of the bushing including areas having a reduced thickness and projections on the internal surface of the areas having a reduced thickness; and

[0017] Figure 11 illustrates a top view of the bushing showing the projections on the internal surface of the areas having a reduced thickness.

DETAILED DESCRIPTION OF THE PREFERRED EMBODIMENTS

[0018] Figure 1 illustrates a vehicle seat 10 includes a seat 12 and a backrest 14. The vehicle seat 10 includes a headrest 16 that is movable in a generally vertical direction (along an axis Z) relative to the backrest 14. At least one post 18 is secured to the headrest 16. In one example, the vehicle seat 10 includes two posts 18. One of the posts 18 includes a plurality of notches 42, as explained below. The post 18 has a diameter C.

[0019] Figure 2 illustrates a top portion of the backrest 14 of the vehicle seat 10. A guide sleeve 20 corresponding to each post 18 is received within the backrest 14. In one example, the guide sleeve 20 is made of metal. In one example, there are two guide sleeves 20. A bushing 22a and 22b is received in each of the guide sleeves 20. In one example, the bushing

22a is a master bushing, and the bushing 22b is a slave bushing. That is, the master bushing is actuated to allow movement of the headrest 16 relative to the backrest 14 of the vehicle seat 10. As explained below, a mechanism of the bushing 22a is manually actuated to allow the post 18, and therefore the headrest 16, to move relative to the backrest 14.

[0020] Figure 3 illustrates the bushing 22a. In one example, the bushing 22a is made of molded plastic. The bushing 22a includes a body portion 24 that is received inside one of the guide sleeves 20. The body portion 24 includes an internal passageway 26 that extends along the axis Z. The body portion 24 also includes a resilient feature 40 that is received in an opening (not shown) in the guide sleeve 20. When the body portion 24 is inserted into the guide sleeve 20, the resilient feature 40 is compressed inwardly to allow the body portion 24 to slide within to the guide sleeve 20. However, once the resilient feature 40 is aligned with the opening, the resilient feature 40 is biased outwardly into the opening to retain the body portion 24 within the guide sleeve 20.

[0021] The bushing 22a also includes a head portion 28 that defines a space 30 accessible through an opening 32 on a first side 34 of the head portion 28. The head portion 28 also includes a wall 36 (shown in Figure 4) on a second side 38 of the head portion 28. The head portion 28 also includes passageway opening 44 aligned with the internal passageway 26 of the body portion 24. In one example, the body portion 24 and the head portion 28 are integrally formed into a single component.

[0022] Figures 4 and 5 illustrate a moveable portion 46 received in the space 30 of the head portion 28. In one example, the head portion 28 is formed of molded plastic. The moveable portion 46 includes a manual contact surface 48, an opposing spring surface 50 and a passage 52 that is alignable with the passageway 26 of the body portion 24 and the passageway openings 44 of the head portion 28. A metal piece 54, such as a steel sheet, is molded into or snap fit in the moveable portion 46. In one example, the metal piece 54 is a metal plate. A resilient member 56 is located between the wall 36 of the head portion 28 and the spring surface 50 of the moveable portion 46. In one example, the resilient member 56 is a coil spring. The metal piece 54 and the resilient spring 56 are two separate components that are non-integral.

[0023] As shown in Figure 4, when the moveable portion 46 is in a first position, the resilient member 56 biases the moveable portion 46 in a direction X to a first position such that a portion of the metal piece 54 is received within a notch 42 of the post 18 that is received in the passageway openings 44 of the head portion 28, the passage 52 of the moveable portion 46, and the passageway 26 of the body portion 24. Engagement of the metal piece 54 in the notch 42 of the post 18 secures the post 18, and therefore the headrest 16, in a position.

[0024] As shown in Figure 5, when pressure is applied on the manual contact surface 48 of the moveable portion 46 (for example, by a finger of a person), the moveable portion 46 moves in the direction Y to a second position and compresses the resilient member 56. When the moveable portion 46 is in the second position, the metal piece 54 is not received in a notch 42 in the post 18, allowing the post 18, and therefore the headrest 16, to move axially along the axis Z relative to the backrest 14 and the bushing 22a.

[0025] When the pressure is released from the manual contact surface 48 of the moveable portion 46, the resilient member 56 biases the moveable portion 46 back to the first position, as shown in Figure 4. The metal piece 54 engages another notch 42 of the post 18, securing the post 18, and therefore the headrest 16, in another position.

[0026] As shown in Figure 6, the moveable portion 46 includes a flexible projection 58 (shown in Figures 7 and 8) that is received in an opening 60 in the head portion 28 when the moveable portion 46 is received in the space 30 of the head portion 28. The flexible projection 58 retains the moveable portion 46 within the opening 60 of the head portion 28. As the moveable portion 46 moves between the first position and the second position, the flexible projection 58 moves within the opening 60 of the head portion 28 to removably retain the moveable portion 46 inside the head portion 28.

[0027] As shown in Figure 9, the bushing 22a also includes a collar 62 located between the body portion 24 and the head portion 28. The collar 62 includes an opening 64 having a flat bottom surface 66 and a curved upper surface 68. A flexible wall 70 is defined between the flat bottom surface 66 of the opening 64 and a lower surface 72 of the collar 62. A rib 74 projects from the lower surface 72 of the collar 62 (Figure 2). When the bushing 22a is positioned in the guide

sleeve 20, the flexible wall 70 and the rib 74 are deformable and contact an upper surface of the guide sleeve 20 to absorb impact.

[0028] As shown in Figure 10, the body portion 24 includes an area 76 having a reduced wall thickness. That is, a thickness of the area 76 is less than a thickness of the surrounding wall of the body portion 24 of the bushing 22. In one example, the area 76 is substantially rectangular. In one example, the area 76 is recessed from an external side of the body portion 24. That is, an inner surface of the body portion 24 does not include any recessed portion as part of the area 76 and is substantially smooth in this area. In one example, the body portion 24 includes two areas 76 on opposing sides of the body portion 24. The area 76 is continuous with the surrounding wall of the body portion 24, and there are no spaces or gaps between the area 76 and the surrounding wall of the body portion 24. In one example, the area 76 is located between the collar 62 and the resilient feature 40. As the area 76 has a thickness less than the thickness of the surrounding material of the body portion 24, it is more flexible.

[0029] The body portion 24 includes an elongated rib 78 located on an inner surface of the passageway 26 of the body portion 24 and aligned with the area 76 having a reduced wall thickness. The elongated rib 78 extends along the X axis. In one example, there are two elongated ribs 78 each aligned with one of the two areas 76 of reduced wall thickness. In one example, each elongated rib 78 is located across from the other elongated rib 78. A diameter of the passageway 26 of the body portion 24 has a diameter A, and a distance between the two elongated ribs 78 is a distance B. The distance B is less than the distance A. Additionally, the diameter C of the post 18 is slightly greater than the distance B between the elongated ribs 78.

[0030] When the post 18 is received in the passageway 26 of the body portion 24 of the bushing 22a, the larger diameter post 18 presses on the elongated ribs 78 as the distance B between the elongated ribs 78 is less than the diameter C of the post 18. As the area 76 has a reduced wall thickness, the area 76 can flex when the larger diameter post 18 is located between the smaller distance elongated ribs 78. As the post 18 is moved within the passageway 26 of the body portion 24, the post 18 continues to press on the elongated ribs 78, providing friction which allows for better control of the movement of the post 18 when the post 18 is being moved to adjust a location of the headrest 16. The contact also decreases buzz, squeak and rattle of the mechanism.

[0031] When the headrest 16 is to be moved along the Z axis to another position, the manual contact surface 48 of the moveable portion 46 is pressed, removing the metal piece 54 from one of the notches 42 in the post 18. This allows the post 18, and the attached headrest 18, to move to a desired position along the axis Z. Once the headrest 16 is in the desired position, the manual contact surface 48 is released, and the resilient member 56 biases the moveable portion 46 into another notch 42 of the post 18, securing the headrest 16 in a new position.

[0032] The foregoing description is only exemplary of the principles of the invention. Many modifications and variations are possible in light of the above teachings, for instance, the inlet vanes may also have intermediate positions. It is, therefore, to be understood that within the scope of the appended claims, the invention may be practiced otherwise than using the example embodiments which have been specifically described. For that reason the following claims should be studied to determine the true scope and content of this invention.

CLAIMS

What is claimed is:

1. A bushing to allow adjustability of a position of a headrest, the bushing comprising:
a head portion having an opening and a passageway opening;
a body portion defining an internal passageway, wherein the passageway opening of the head portion is aligned with the internal passageway of the body portion, the body portion includes a wall surrounding an area of reduced thickness, and a protrusion is located on an internal surface of the area of reduced thickness; and
a moveable portion received in the opening of the head portion, wherein the moveable portion is moveable between a first position wherein a feature engages a notch of a post receivable in the internal passageway of the body portion and the passageway opening of the head portion to retain the headrest in a position, and a second position wherein the feature is disengaged from the notch of the post, allowing the post and the headrest to move relative to the bushing.
2. The bushing as recited in claim 1 wherein the body portion includes two areas of reduced thickness and two protrusions, wherein one of the two areas of reduced thickness and one of the two protrusions and the other of the two areas of reduced thickness and other of the two protrusions are located across from each other, a first distance is defined between the internal surfaces of the two areas of reduced thickness, a second distance is defined between the two projections, and the second distance is less than the first distance.
3. The bushing as recited in claim 1 wherein the head portion and the body portion are integral and made of molded plastic.
4. The bushing as recited in claim 1 wherein the head portion includes a first side and a second side, wherein the opening is located at the first side and a wall is located near the second side.

5. The bushing as recited in claim 4 including a resilient member located between the moveable portion and the wall of the head portion.
6. The bushing as recited in claim 5 wherein the resilient member is a coil spring.
7. The bushing as recited in claim 5 wherein the resilient member biases the moveable portion to the first position, and manual pressure moves the moveable portion to the second position against the bias of the resilient member.
8. The bushing as recited in claim 1 wherein the feature that engages the notch of the post is a metal piece.
9. The bushing as recited in claim 8 wherein the metal piece is molded into the moveable portion or snap fit into an opening in the moveable portion.
10. The bushing as recited in claim 8 wherein a resilient member biases the moveable portion to the first position, manual pressure moves the moveable portion to the second position against the bias of the resilient member, and the resilient member and the metal portion are separate components.
11. The bushing as recited in claim 1 wherein the head portion includes an aperture and the moveable portion includes a projection that is received in the aperture to removeably retain the moveable portion in the head portion as the moveable portion moves relative to the head portion.
12. The bushing as recited in claim 1 wherein the protrusion is elongated and extends along a substantially vertical axis.

13. A headrest assembly comprising:
- a headrest;
 - two posts secured to the headrest, wherein at least one of the two posts includes a plurality of notches; and
 - a bushing to allow adjustability of a position of the headrest, the bushing including:
 - a head portion having an opening and a passageway opening,
 - a body portion defining an internal passageway, wherein the passageway opening of the head portion is aligned with the internal passageway of the body portion, the body portion includes a wall surrounding two areas of reduced thickness on opposing sides of the body portion, a protrusion is located on an internal surface of each of the two areas of reduced thickness, a first distance is defined between the internal surfaces of the two areas of reduced thickness, a second distance is defined between the two projections, the second distance is less than the first distance, and one of the two posts with the plurality of notches is received in the internal passageway of the body portion and the passageway opening of the head portion of the bushing and has a third diameter that is greater than the second distance defined between the two projections, and
 - a moveable portion received in the opening of the head portion, wherein the moveable portion is moveable between a first position wherein a feature engages one of the plurality of notches of the post receivable in the internal passageway of the body portion and the passageway opening of the head portion of the bushing to retain the headrest in a position, and a second position wherein the feature is disengaged from the one of the plurality of notches of the post, allowing the post and the headrest to move relative to the bushing.
14. The headrest assembly as recited in claim 13 wherein the head portion and the body portion are integral and made of molded plastic.

15. The headrest assembly as recited in claim 13 wherein the head portion includes a first side and a second side, wherein the opening is located at the first side and a wall is located near the second side.

16. The headrest assembly as recited in claim 15 including a resilient member located between the moveable portion and the wall of the head portion.

17. The headrest assembly as recited in claim 16 wherein the resilient member is a coil spring.

18. The headrest assembly as recited in claim 16 wherein the resilient member biases the moveable portion to the first position, and manual pressure moves the moveable portion to the second position against the bias of the resilient member.

19. The headrest assembly as recited in claim 13 wherein the feature that engages one of the notches of the post is a metal piece.

20. The headrest assembly as recited in claim 19 wherein the metal piece is molded into the moveable portion or snap fit into an opening in the moveable portion.

21. The headrest assembly as recited in claim 19 wherein a resilient member biases the moveable portion to the first position, manual pressure moves the moveable portion to the second position against the bias of the resilient member, and the resilient member and the metal portion are separate components.

22. The headrest assembly as recited in claim 13 wherein the head portion includes an aperture and the moveable portion includes a projection that is received in the aperture to removeably retain the moveable portion in the head portion as the moveable portion moves relative to the head portion.

23. The headrest assembly as recited in claim 13 wherein the protrusion is elongated and extends along a substantially vertical axis.

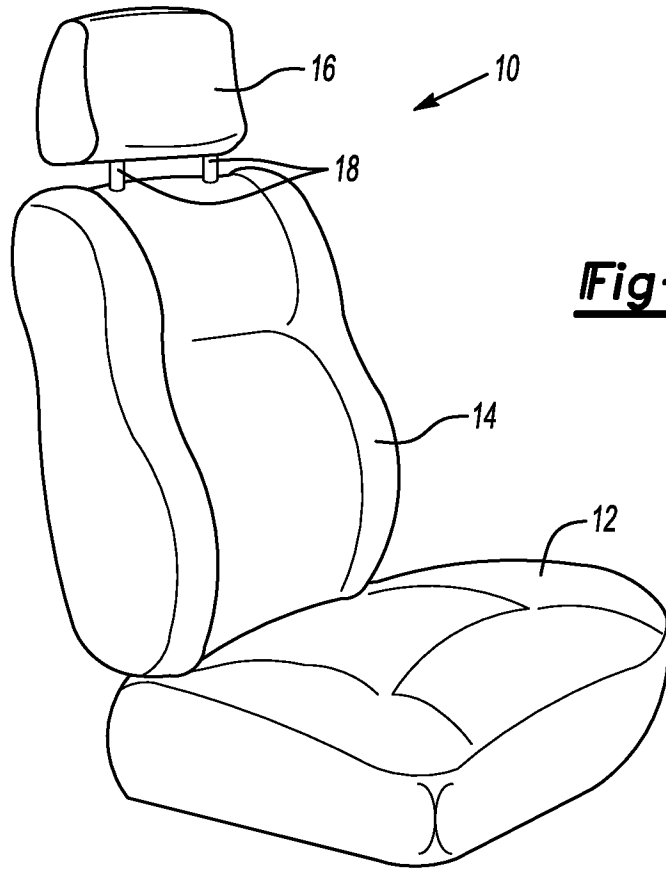

Fig-1

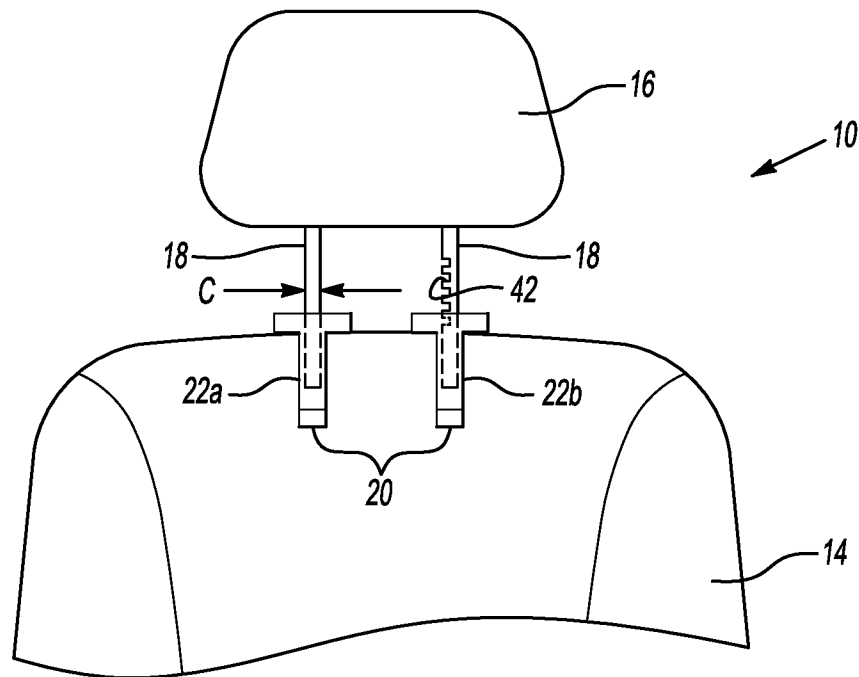

Fig-2

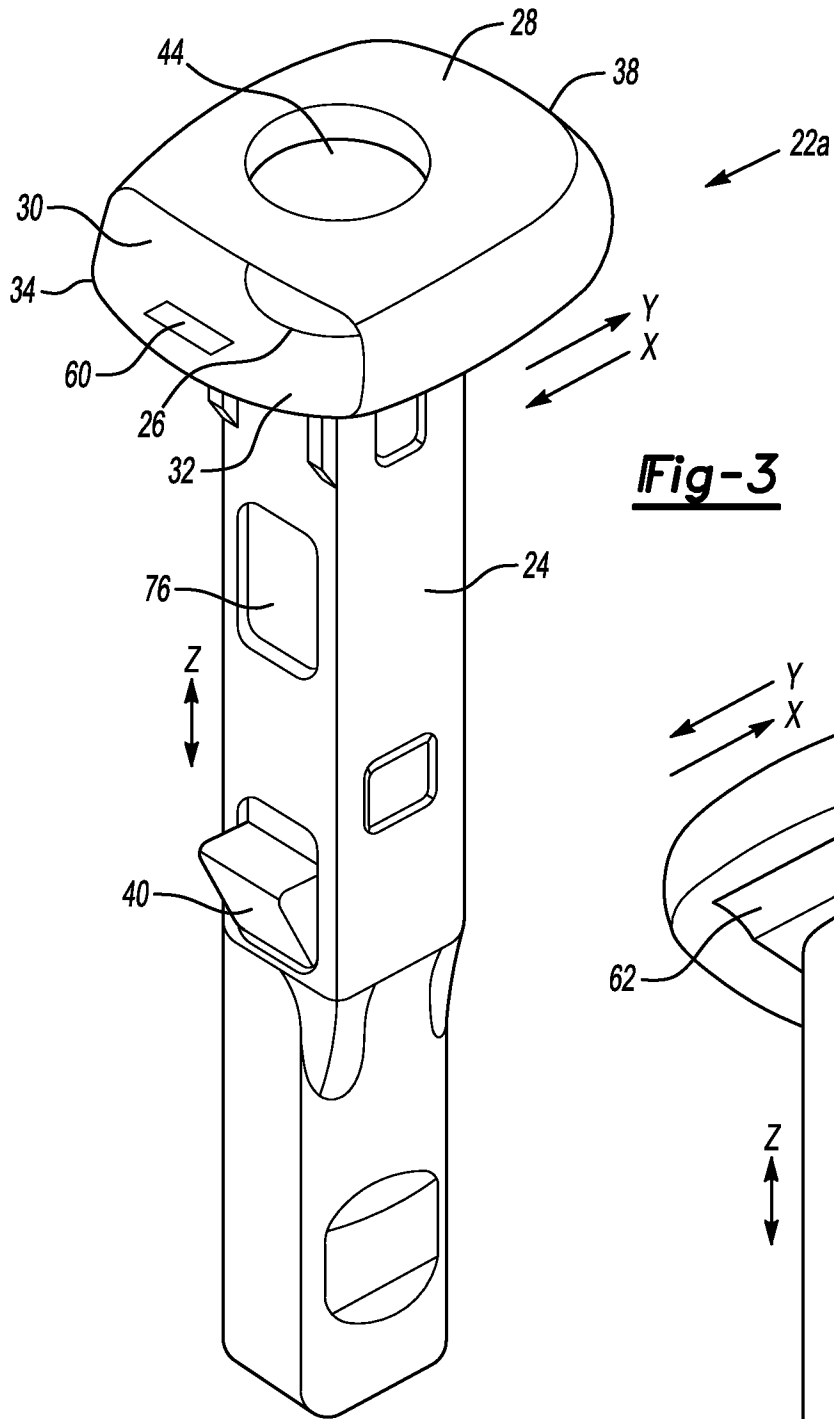

Fig-3

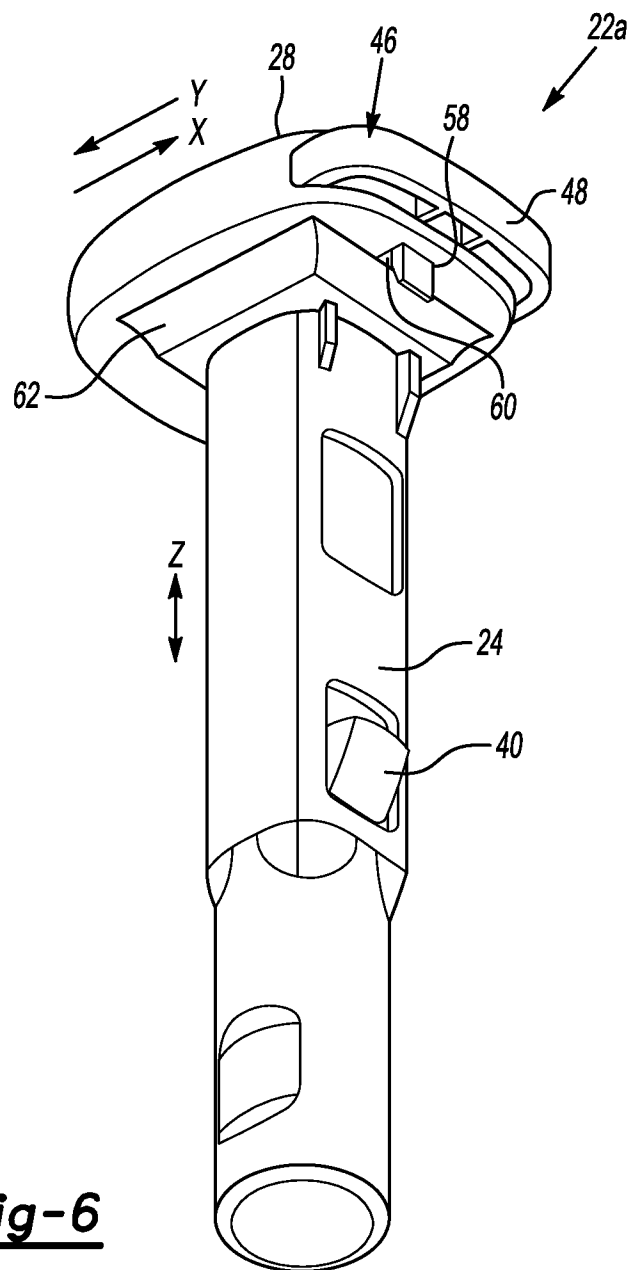

Fig-6

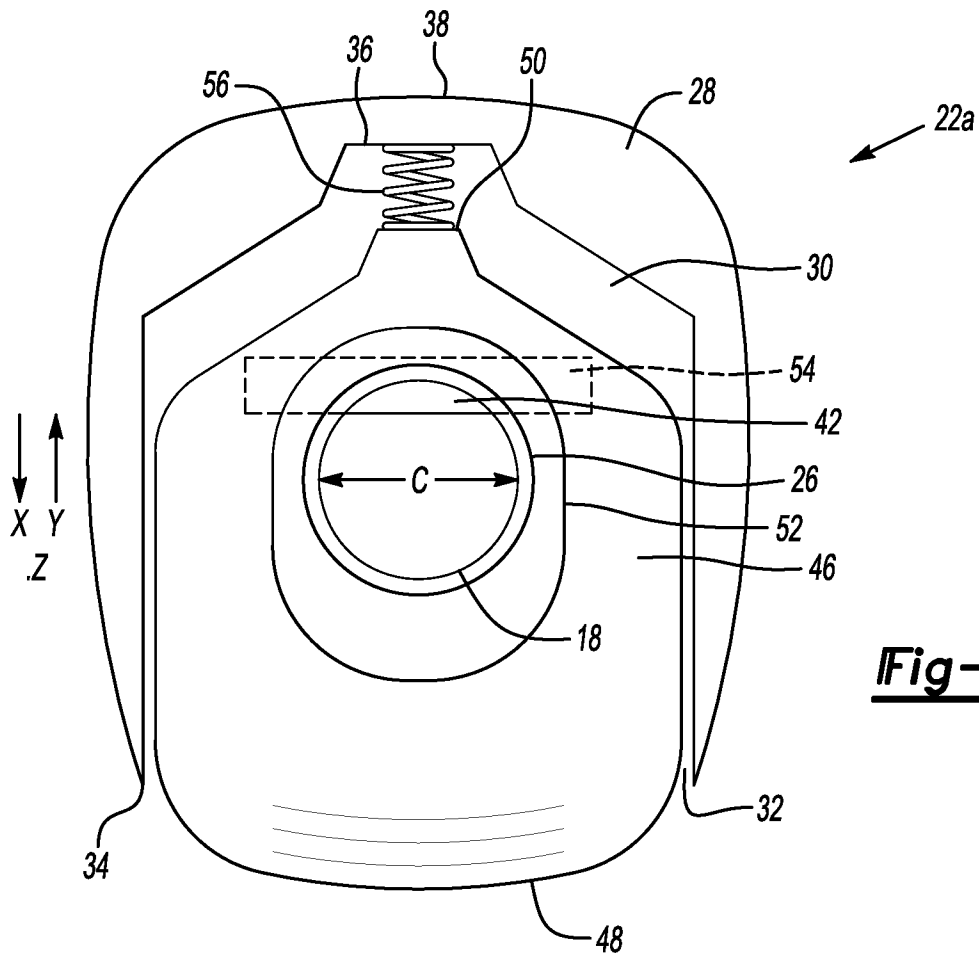

Fig-4

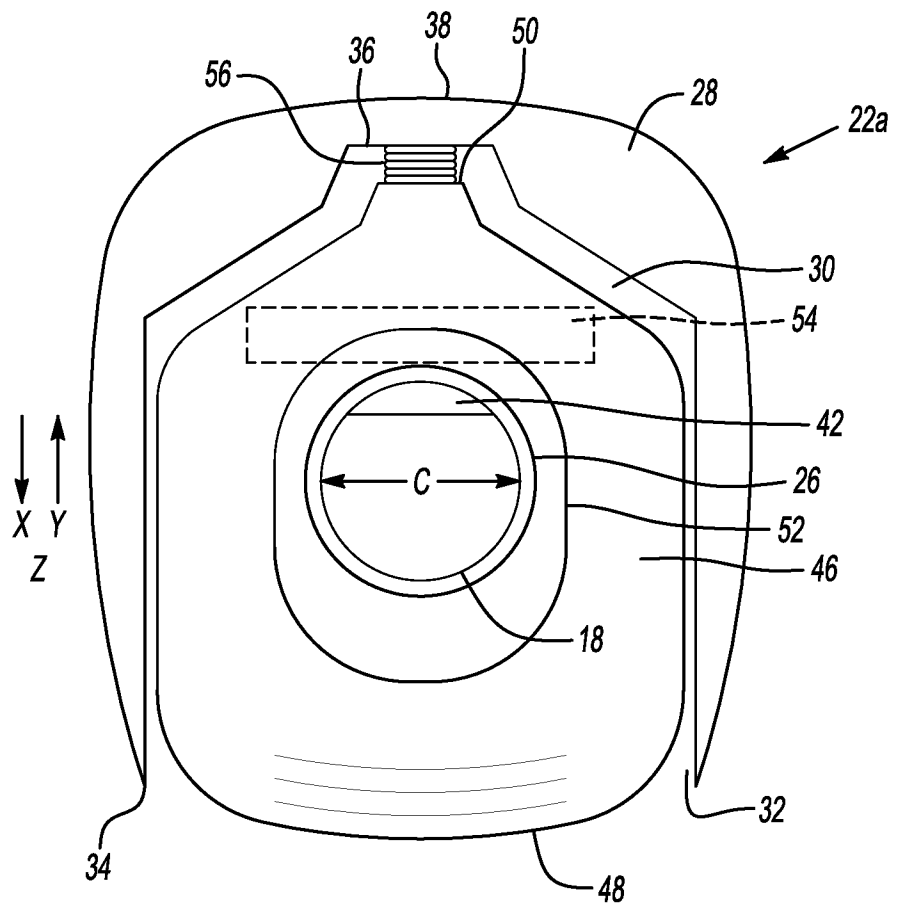

Fig-5

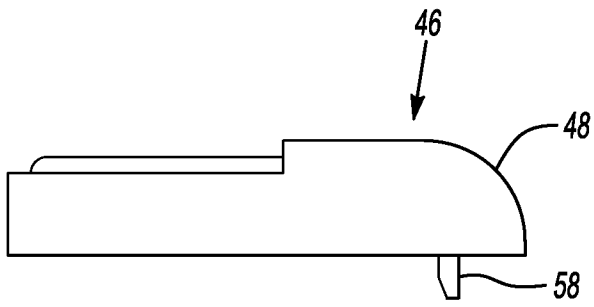

Fig-7

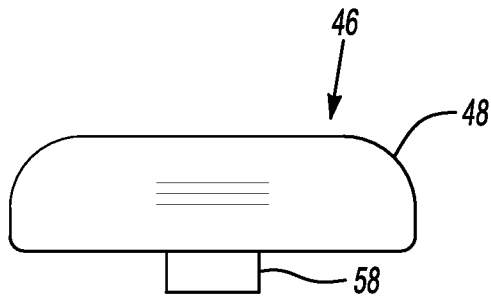

Fig-8

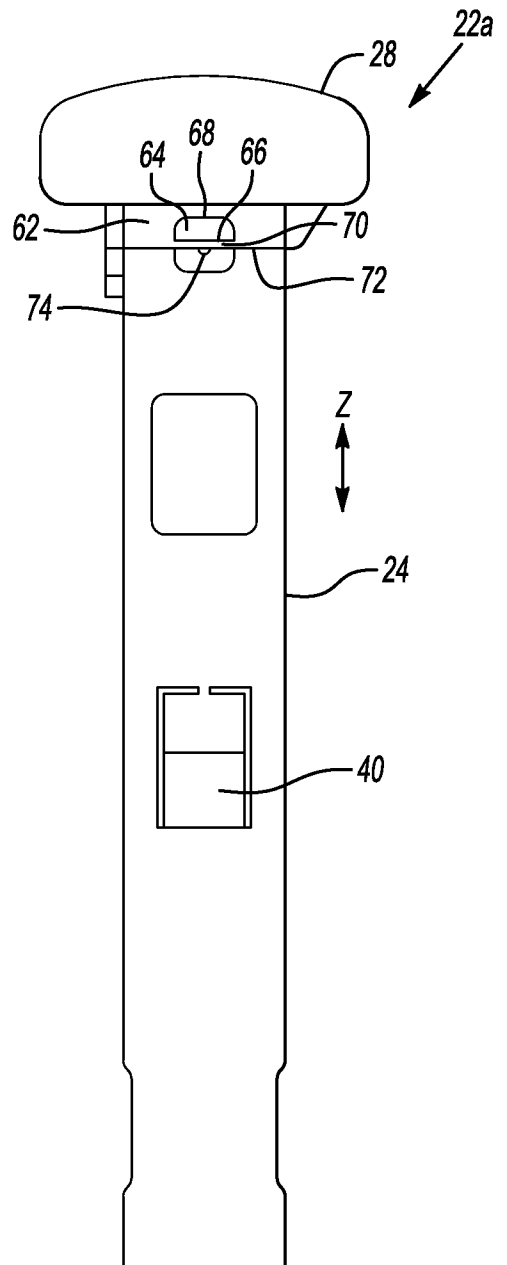

Fig-9

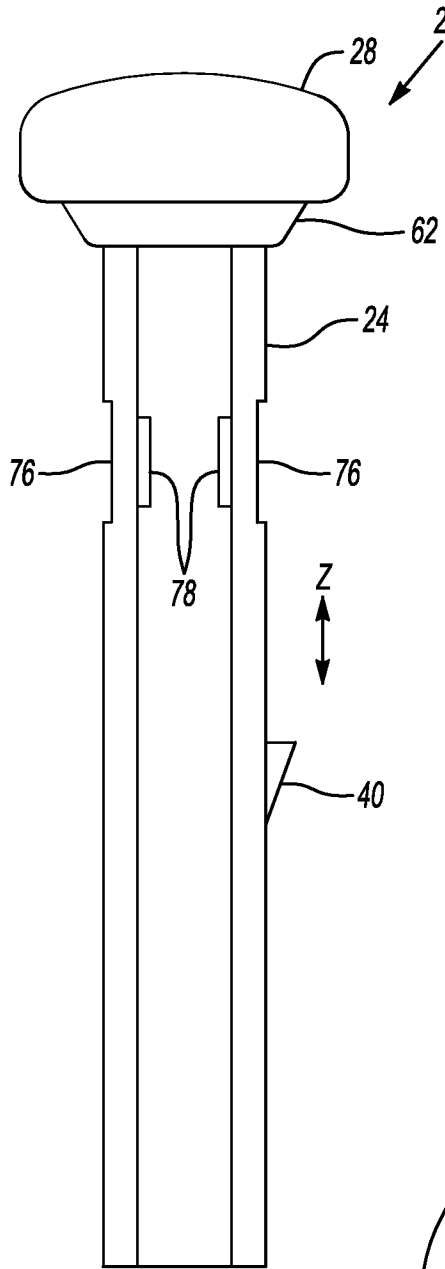

Fig-10

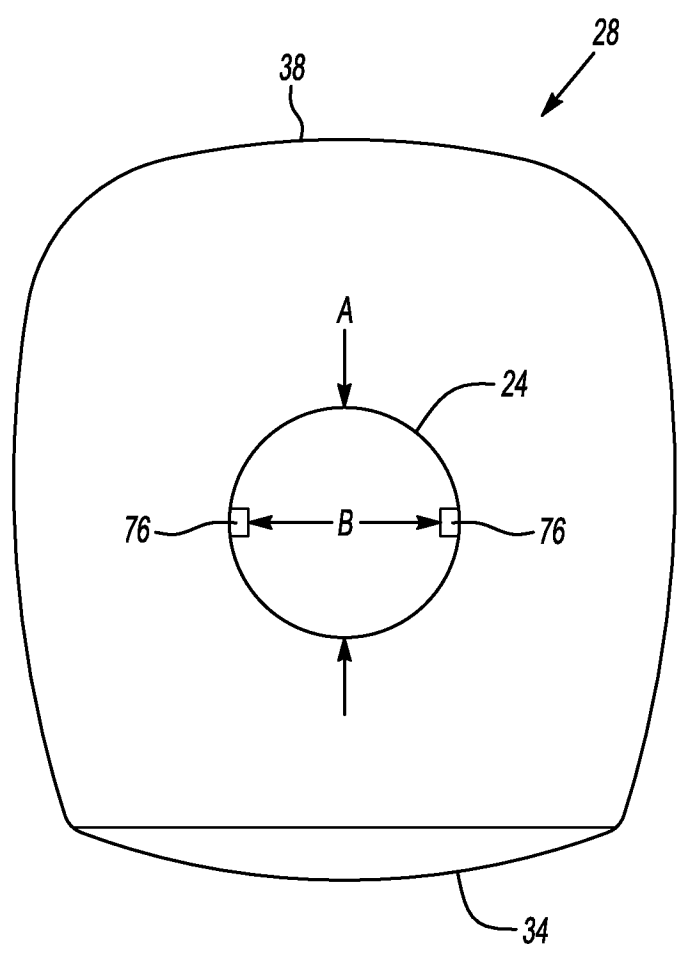

Fig-11

INTERNATIONAL SEARCH REPORT

International application No
PCT/US2013/051554

A. CLASSIFICATION OF SUBJECT MATTER
 INV. B60N2/48
 ADD.
 According to International Patent Classification (IPC) or to both national classification and IPC

B. FIELDS SEARCHED
 Minimum documentation searched (classification system followed by classification symbols)
 B60N

Documentation searched other than minimum documentation to the extent that such documents are included in the fields searched

Electronic data base consulted during the international search (name of data base and, where practicable, search terms used)
 EPO-Internal, WPI Data

C. DOCUMENTS CONSIDERED TO BE RELEVANT

Category*	Citation of document, with indication, where appropriate, of the relevant passages	Relevant to claim No.
X	US 5 738 413 A (DE FILIPPO EMILIO [IT]) 14 April 1998 (1998-04-14) the whole document -----	1-23
X	US 5 860 703 A (COURTOIS BERNARD [FR] ET AL) 19 January 1999 (1999-01-19) the whole document -----	1-23
X	DE 196 31 100 A1 (GRAMMER AG [DE]) 5 February 1998 (1998-02-05) the whole document -----	1-4, 13
A		5-12, 14-23
X	US 5 667 276 A (CONNELLY JOHN M [US] ET AL) 16 September 1997 (1997-09-16) the whole document -----	1-23

Further documents are listed in the continuation of Box C. See patent family annex.

* Special categories of cited documents :

"A" document defining the general state of the art which is not considered to be of particular relevance	"T" later document published after the international filing date or priority date and not in conflict with the application but cited to understand the principle or theory underlying the invention
"E" earlier application or patent but published on or after the international filing date	"X" document of particular relevance; the claimed invention cannot be considered novel or cannot be considered to involve an inventive step when the document is taken alone
"L" document which may throw doubts on priority claim(s) or which is cited to establish the publication date of another citation or other special reason (as specified)	"Y" document of particular relevance; the claimed invention cannot be considered to involve an inventive step when the document is combined with one or more other such documents, such combination being obvious to a person skilled in the art
"O" document referring to an oral disclosure, use, exhibition or other means	"&" document member of the same patent family
"P" document published prior to the international filing date but later than the priority date claimed	

Date of the actual completion of the international search 6 December 2013	Date of mailing of the international search report 13/12/2013
--	--

Name and mailing address of the ISA/ European Patent Office, P.B. 5818 Patentlaan 2 NL - 2280 HV Rijswijk Tel. (+31-70) 340-2040, Fax: (+31-70) 340-3016	Authorized officer Zevelakis, Nikolaos
--	---

INTERNATIONAL SEARCH REPORT

Information on patent family members

International application No PCT/US2013/051554

Patent document cited in search report	Publication date	Patent family member(s)	Publication date
US 5738413	A	14-04-1998	BR 9606227 A 25-08-1998
			DE 69616042 D1 22-11-2001
			EP 0819571 A2 21-01-1998
			IT T0960614 A1 16-01-1998
			PL 317573 A1 19-01-1998
			TR 9601061 A2 21-02-1998
			US 5738413 A 14-04-1998

US 5860703	A	19-01-1999	DE 69702229 D1 13-07-2000
			DE 69702229 T2 04-01-2001
			EP 0822117 A1 04-02-1998
			FR 2751926 A1 06-02-1998
			US 5860703 A 19-01-1999

DE 19631100	A1	05-02-1998	NONE

US 5667276	A	16-09-1997	DE 19645824 A1 03-07-1997
			FR 2743033 A1 04-07-1997
			US 5667276 A 16-09-1997
