

(19) World Intellectual Property Organization
International Bureau



(43) International Publication Date
28 December 2000 (28.12.2000)

PCT

(10) International Publication Number
WO 00/79406 A1

(51) International Patent Classification⁷: G06F 15/16, 15/173

(21) International Application Number: PCT/US00/17269

(22) International Filing Date: 23 June 2000 (23.06.2000)

(25) Filing Language: English

(26) Publication Language: English

(30) Priority Data:
09/339,468 23 June 1999 (23.06.1999) US

(71) Applicant: INFOLIO, INC. [US/US]; 1960 Zanker Road, San Jose, CA 95112 (US).

(72) Inventors: WATANABE, Ryoji; 22284 Palm Avenue, Cupertino, CA 95014 (US). FUNG, Henry, T.; 3453 Varner Court, San Jose, CA 95132 (US). ALPDEMIR, Ahmet; 2318 Oak Flat Road, San Jose, CA 95131 (US). BABBAR, Raj; 45365 Potawatami Drive, Fremont, CA 94539 (US).

(74) Agents: ANANIAN, R., Michael et al.; Flehr Hohbach Test Albritton & Herbert LLP, Suite 3400, 4 Embarcadero Center, San Francisco, CA 94111-4187 (US).

(81) Designated States (national): AE, AG, AL, AM, AT, AU, AZ, BA, BB, BG, BR, BY, BZ, CA, CH, CN, CR, CU, CZ, DE, DK, DM, DZ, EE, ES, FI, GB, GD, GE, GH, GM, HR, HU, ID, IL, IN, IS, JP, KE, KG, KP, KR, KZ, LC, LK, LR, LS, LT, LU, LV, MA, MD, MG, MK, MN, MW, MX, MZ, NO, NZ, PL, PT, RO, RU, SD, SE, SG, SI, SK, SL, TJ, TM, TR, TT, TZ, UA, UG, UZ, VN, YU, ZA, ZW.

(84) Designated States (regional): ARIPO patent (GH, GM, KE, LS, MW, MZ, SD, SL, SZ, TZ, UG, ZW), Eurasian patent (AM, AZ, BY, KG, KZ, MD, RU, TJ, TM), European patent (AT, BE, CH, CY, DE, DK, ES, FI, FR, GB, GR, IE, IT, LU, MC, NL, PT, SE), OAPI patent (BF, BJ, CF, CG, CI, CM, GA, GN, GW, ML, MR, NE, SN, TD, TG).

Published:

- With international search report.
- With amended claims.

For two-letter codes and other abbreviations, refer to the "Guidance Notes on Codes and Abbreviations" appearing at the beginning of each regular issue of the PCT Gazette.

(54) Title: SYSTEM AND OPERATING METHOD FOR AN INTERNET-BASED CONTENT ADAPTATION SERVICE

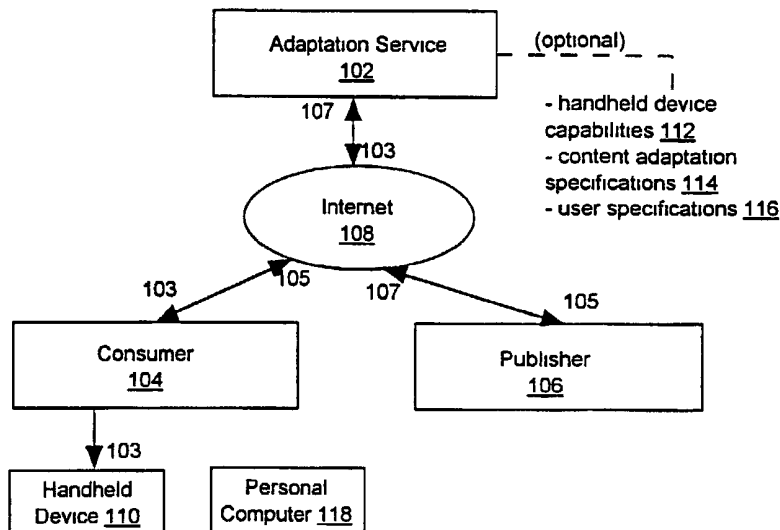

(57) Abstract: A system and operating model and method for an Internet-based adaptation service (102), utilizing a consumer (103) and a publisher (105) in communication via Internet (108). The adaptation service transforms Internet content into an adapted form that can be used on a handheld device (110) that cannot not use conventional Internet content. The adaptation service generates the adapted content in accordance with preferences of the Internet content provider. Among other things, these preferences can cover appearance, functionality and advertizing content of the adapted content. The adaptation service ensures that the handheld can use the content in part by transforming the Internet content based on known capabilities of the target handheld.



WO 00/79406 A1

SYSTEM AND OPERATING METHOD FOR AN INTERNET-BASED CONTENT ADAPTATION SERVICE

Field of the Invention

The present invention relates to a system and operating method for use by content providers who wish to provide to end users content adapted for use on computers that could possibly be intermittently connected to the Internet.

BACKGROUND OF THE INVENTION

A typical Internet user is able to access content whenever he or she desires. This is because most users access the Internet using computers with always-available Internet connections (e.g., persistent or dialup hardwired connections, or wireless connections). However, more users are beginning to access and/or view Internet content from handheld/portable computers, or other information devices or appliances (hereinafter, "handhelds"), which are only able to connect to the Internet intermittently, if at all. This type of user needs to be able to download Internet content to his or her handheld when it is connected to the Internet directly or indirectly (e.g., via a standalone personal computer or a server that can provide Internet content). Moreover, the downloaded content needs to be structured so that it can be viewed on the portable that is the destination of the downloaded data. Some of these features are provided by various products, including AvantGo™, ProxiNet™, Oracle Panama™, Online Anywhere™ and Palm Query Apps., which are now described.

AvantGo is viewer for Internet content that can be installed on a variety of portables running the PalmOS™ or WindowsCE™ operating systems. AvantGo can be used to view HTML content that has been re-authored for compatibility with the AvantGo viewer by content providers, such as CNNfn™, The Wall Street Journal™ and the New York Times™.

5 AvantGo can also be used to view Internet content that has not been re-authored, but such content could be difficult to view on handhelds, but this is not a key aspect of the AvantGo model. Re-authored content is provided by the content providers and is stored on Internet servers that also serve conventional Internet content from the providers. As a result, the AvantGo system requires content providers to commit additional resources (e.g., time/effort

10 to reauthor content, server resources) to support handheld users of AvantGo. Typically, users who wish to download content to AvantGo must do so via an Internet server running AvantGo Server software, or via a personal computer or kiosk (e.g., via a docking station) with an Internet connection. Additional information on AvantGo can be obtained at the AvantGo.com web site.

15

Another system for delivering Internet content to handheld users is Oracle's Project Panama. "Oracle Project Panama is capable of dynamically transforming existing Internet content to a generic XML format, and then generating any device specific output desired. Examples of markup languages supported include HTML, WML, HDML, TTML and

20 VoxML." Project Panama White Paper," available at <http://www.oracle.com/mobile/panama/panampwp.htm> (March 1999). Project Panama provides a service creation environment that allows content providers to create a web service that makes their content available to all mobile devices. The service creation environment creates the generic XML web service representation based on analysis of

25 the web site. "The analysis can be done either by an [sic] system administrator for more complex transaction based web services or by the end user for more simple types of information services." *Id.* Project Panama also provides a personalized portal from which a user of a mobile, Internet-connected device can access the web. A drawback of Project Panama is that it is a piece of software that must be loaded onto a server and not a pure

30 web service that can be accessed and employed by any content provider with Internet access. Another drawback of Project Panama is that, because end users are allowed solely to perform the web site analysis that determines how the site will look on their handhelds, content providers will not necessarily be able to ensure consistency and quality of their

web site when viewed from handheld devices. That is, Project Panama does not allow content providers to configure via a pure web-based interface adaptation of their web content. This and other systems that allow content adaptation without the approval of content providers could run afoul of copyright law, which grants to copyright holders the exclusive right to create derivative works, which could conceivably include adapted versions of copyrighted online content. Additionally, allowing users to determine how a web site is presented on a handheld could mean lost opportunities for selling advertising placed with the downloaded content.

ProxiNet is yet another system for providing Internet content to users of handheld devices. ProxiNet is based on the idea of providing proxy servers between users and Web servers that offload web processing from the users' handheld devices. In this system, when a user requests Internet content, a proxy server "distills" in real-time the requested content to a format appropriate to the capabilities of the handheld device. The distilled content is not represented using HTML. Once downloaded to the handheld device, the distilled web pages are displayed by proprietary ProxiWeb client software therefore, the ProxiNet service only needs to support one distillation format and one client application. ProxiNet does not allow content providers to configure adaptation. Additional information on the concepts underlying ProxiNet can be found in: "Adapting to Network and Client Variation Using Infrastructural Proxies: Lessons and Perspectives," Armando Fox, Steven D. Gribble, Yatin Chawathe, Eric A. Brewer, *available at* <http://www.ProxiNet.com/papers>.

Online Anywhere is a piece of software that allows content providers to configure the adaptation of their software. At present, the Online Anywhere software is not a centralized service that can be accessed by any content provider with Internet access. Rather, the content providers need to load the Online Anywhere software on their own (or their ISP's) server before performing content adaptation.

Finally, PalmVII™ systems provide a methodology for providing filtered access to web pages via client software called Palm Query Applications. This system is similar to AvantGo in that the Palm Query Application (PQA) must be written in special form of HTML, however, compared to AvantGo, an additional step is also involved wherein the programmer uses an installed development tool (the Query Application Builder) to

turn the HTML into a query application, which is then made available to end users for installation and use. More information on PQAs can be found at <http://www.palm.com/devzone/palmvii>.

5 Additionally, it appears that none of the preceding systems are able to merge at a central site (i.e., at a site removed from a content provider's web site) and in real-time complementary content, such as advertising, with content requested by users of handhelds. The lack of this ability prevents content providers from gaining additional revenues from providing content to users of handhelds who are using specially formatted content.

10

 Therefore, there is a need for an Internet-based content transformation service that enables users to acquire content that is configured for their handheld devices in a format that is approved by the content providers. There is a further need for such a service where the content providers can specify the format of the transformed content without needing to perform laborious web site analysis. There is also a need for an Internet-based content transformation service that enables appropriate advertising to be inserted into the transformed content. There is a further need for such a service that performs content transformation in real-time, freeing content providers from storing as many different forms of content as types of supported platforms. In addition, there is a further need for such a service wherein the users of the service are not required to have an Internet connection for their handheld devices.

15

20

SUMMARY

 The present invention is a system, operating model and method for an Internet-based, content adaptation service. In particular, a system and operating model implemented in accordance with the present invention includes a publisher, a consumer and an adaptation service. The publisher provides Internet content. The consumer employs a handheld device, laptop computer, notebook computer, desktop personal computer, or other information appliance (the invention is most advantageous for, but not limited to, a handheld device) to use an adapted version of the Internet content. The adaptation service transforms the Internet content to the adapted version for use by the consumer. The adapted version is formatted so as to be compatible with capabilities of the handheld device or other computer or information appliance and content transformation specifications of the

25

30

publisher indicating preferences regarding at least the appearance of the adapted version. Additionally, the adaptation service can be configured to merge complementary content with the adapted version. The complementary content can include advertising, editorial content or other content related to the adapted content. The adaptation service can also
5 be configured to obtain approval from content providers for the modification of their content.

More generally, the present invention is a business method for an Internet based content adaptation service that enables a publisher to make Internet content available to
10 users of handheld devices, laptop computers, notebook computers, desktop personal computers, or other information appliances. The adaptation service is hosted on the Internet and provides a pure, web-based interface via which the publisher can specify characteristics of an adapted version of the Internet content for use on handheld devices. The adaptation service is configured to transform the Internet content to the adapted version in accordance
15 with the publisher-specified characteristics.

Typically, interested users can obtain the content via a pure, web-based user interface. However, the present invention can be implemented so that users can also obtain the content via e-mail or any other digital communication means. The invention also
20 provides a computer program, computer program modules, and computer product embodying the models, method, and procedures described herein.

BRIEF DESCRIPTION OF THE DRAWINGS

Additional objects and features of the invention will be more readily apparent from
25 the following detailed description and appended claims when taken in conjunction with the drawings, in which:

FIG. 1A is a schematic of a basic embodiment of an adaptation service implemented in accordance with the present invention;

FIG. 1B is a schematic of an elaboration of the basic embodiment of the adaptation
30 service shown in FIG. 1A;

FIG. 1C is a schematic of an extension of the embodiments of the adaptation service shown in FIGS. 1A and 1B;

FIG. 2 is a block diagram of an embodiment of the present invention showing details of computers 240, 220, 202 employed, respectively by an adaptation server, publisher and consumer;

FIGS. 3A-3C are diagrams of a sequence of screens presented by the adaptation service to a consumer who needs to generate an adapted version of Internet content;

FIG. 4 are flow diagrams illustrating a series of operations performed on a consumer's computer 202, publisher's server 220 and adaptation server 240 in the course of adapting Internet content for use by a particular user on a particular type of handheld device; and

FIG. 5 is a block diagram of an alternative embodiment where the client computer is configured with a client software agent that can download on schedule adapted content placed by a user in a software market basket;

FIG. 6 is a block diagram of an alternative embodiment including a library site that collects adapt links for a set of adaptable content items;

FIG. 7 is a block diagram of an alternative embodiment wherein the adaptation service 102 and a publisher/content provider 106 communicate configuration and adaptation information via e-mail; and

FIG. 8 is a block diagram of an alternative embodiment wherein the adaptation service 102 can send a consumer 104 exchange meta-information about Internet content.

DETAILED DESCRIPTION

Referring to FIG. 1A, there is shown a diagram of a basic embodiment of an adaptation service 102 implemented in accordance with the present invention. The adaptation service 102 is coupled to content consumers 104 and publishers 106 via the Internet 108. In the illustrated embodiment, all interactions between the adaptation service 102, the consumers 104 and the publishers 106 are via standard Internet (i.e., web-based) front-ends, although special-purpose front-ends could also be used.

In one embodiment, the adaptation service 102 transforms in real-time Internet content 107 from the publishers 106 into adapted content 103 used by the customers 104. The adaptation service 102 initiates a transformation in response to an Internet request 105 from a consumer 104 that invokes the adaptation service 102. For example, a consumer 104 might invoke the service 102 by selecting a characteristic icon displayed by all web

pages that can be transformed by the adaptation service. After transforming the requested content 107 the service 102 downloads the adapted content 103 to the consumer 104. In some embodiments, the adaptation service 102 can cache the adapted content so that it can be speedily delivered to other consumers 104 with similar requests 105. It will also
5 be apparent from the description provided here, that while we describe aspects of the inventive structure and method relative to transforming Internet content in real-time, in at least one embodiment of the invention, the transformation may be performed in non-real time, such as transformation on demand or transformation according to a predetermined schedule that transforms the content and caches or otherwise stores the content until the
10 consumer makes the demand, or according to a predetermined schedule. For example, a non-real-time procedure may involve transforming the content at 5:00 am every morning in anticipation of a consumer making a request for the transformed content after 8:00 am.

The consumer 104 can access the adaptation service 102 using any type of client
15 device, including a laptop personal computer, a notebook computer, an information appliance, or a desktop PC that is intermittently connected to the Internet via modem dialup or via a persistent Internet connection, or a handheld device with dialup or persistent Internet access. Since the inventive structure and method are particularly advantageous for a handheld device, we described the inventive structures, procedures, and method with
20 reference to handheld devices; however the invention is not limited to such handheld devices. References to handheld devices in the specification are references to any of these devices. Additionally, the adapted content 103 can be used on any type of viewer, including a handheld device or other computing device or information appliance with no Internet access that is able to receive the adapted content 103 via another, Internet-connected device.

25
Optionally, the adaptation service 102 generates the adapted content 103 in accordance with:

- capabilities 112 of a handheld device 110 used by a particular customer 104 to access the adapted content 103;
 - content adaption specifications 114 indicating preferences of the publisher 106 regarding the method by which the content 107 is adapted by the service 102; and
- 30

- user specifications 116, which can influence, without negating the content adaptation specifications 114 (unless that is allowed by the publisher 106), the content adaptation performed by the adaptation service 102.

5 In different situations the consumer 104 might access the adaptation service 102 from the handheld device or from a personal computer 118 that can download the adapted content 103 to the handheld device 110. The latter configuration is necessary when the handheld device 110 is unable to use Internet content (e.g., because it can't connect to the Internet or does not have the hardware and/or software capabilities to use Internet content). Business models for implementing the adaptation service of FIG. 1A are now
10 described with reference to FIGS. 1B and 1C.

 Referring to FIG. 1B, there is shown a diagram of an adaptation service business model in which the adaptation service 102 includes an adaptation configuration service component 120 used by publishers 106, a content marketplace service component 124
15 used by consumers 102 and an adaptation and delivery engine 122 that generates and delivers the adapted Internet content 103.

A publisher 106 uses the adaptation configuration service 120 to:

- make Internet source content 107 available for adapted republication by the adaptation service 102; and
- configure the adaptation of the source content 107 (e.g., by providing an adaptation specification 114 - FIG. 1A).
- convey their permission to the adaptation of the content 107 and the
25 distribution of the adapted content by the adaptation service 102.

The adaptation specification can indicate, among other things, the URL (Universal Resource Locator) of the source content 107, what subset of the source site should be transformed by the service 102 and how the selected Internet content 107 should be transformed. Publishers can provide one or more specification 114 for each piece of source content,
30 each of the specifications being for a different client device configuration or type.

Consumers 104 use the marketplace service 124 to retrieve adapted content 103 made available by the adaptation service 102 via the delivery engine 122. The marketplace

service 124 can provide adapted content 103 according to at least three different modes of operation:

- a consumer 104 can select an individual content item 107 and download its adapted version 103 immediately;
- 5 ● a consumer 104 can add selected content 107 to a personal “shopping basket” 126 and then take delivery of the corresponding adapted content 103 in a deferred or alternative fashion (e.g., on schedule); or
- in “preview mode,” a consumer 104 can look at what the content 107 will look like after adaptation by browsing the adapted version 103 in some
10 way, without needing to download all of the adapted content 103.

A consumers’s personal shopping basket can be maintained by the adaptation service 102 on its servers or on the consumer’s Internet platform. The consumer’s shopping basket 126 could also be maintained by another business providing a “marketplace” service.

15 Consumers 104 can also use the adaptation service 102 to further personalize the adapted content 103. For example, consumers can specify via the adaptation service 102:

- the capabilities 112 (FIG. 1A) of the target device 110 on which they wish to use/view the content 103; and
- particular sections of the adapted content 103 they are interested in
20 downloading.

One mechanism for informing the adaptation service 102 of the target device capabilities 112 is described in a co-pending U.S. patent application, Universal Mobile ID System and Method for Digital Rights Management (Serial No. 09/237,317), filed by Henry Fung and John Huan Zhao, which is incorporated herein by reference. The marketplace service
25 can be implemented as a public web site, as a private web site, on an intra-enterprise server, as a dialup service or using equivalent technology.

The adaptation and delivery engine 122 transforms selected Internet content 107 into the adapted content 103 in accordance with the adaptation specification 114, the target-
30 device capabilities 112 and any other adaptation information provided by the consumer 104 and/or the publisher 106. The adaptation and delivery engine 122 then downloads the adapted content to the requesting consumer 104 in the conventional manner. Another adaptation service business model is now described with reference to FIG. 1C.

Referring to FIG. 1C, there is shown a diagram of an adaptation service business model in which the adaptation service 102 includes an adaptation configuration service component 120, adaptation and delivery engine 122, content marketplace service component 124 and complementary content 130. As in the embodiment of FIG. 1B, publishers 106 interact with the adaptation configuration service component 120, consumers 104 interact with the content marketplace service component 124 and the adaptation and delivery engine generates and delivers to consumers 104 the adapted content 103. In addition, publishers 106 can ask the adaptation service 102 to merge portions of the complementary content 130 with the adapted content 103. The complementary content 130 can include paid advertising 132, editorial content 134 and other content 136 related to requested content 107.

In one embodiment, the complementary content 130 that is merged with the adapted content 103 is selected based on rules 138 provided by the publisher of the adapted content 103, a requesting consumer's demographic profile (e.g., age, sex, income, education, marital status, interests) 140 and the type 142 of the requested content 107. For example, a publisher 106 of adaptable sports content 107 could include in their adaptation specification 114 a rule directing the adaptation service 102 to merge ads for appropriate sporting equipment into their adapted content 103 if the requesting consumer 104 has indicated an interest in sports. What is appropriate sporting equipment could be determined by the adaptation service 102 or specified in detail by the publisher 106. Additional details of a representative embodiment are now described with respect to FIG. 2.

Referring to FIG. 2, there is shown is a block diagram of an embodiment of the present invention showing details of computers 240, 220, 202 employed, respectively by an adaptation service 102, publisher 106 and a representative Internet user/consumer 104. Each of the computers 240, 220, 202 has an associated memory 242, 222, 203 in which are stored programs and data used for the respective computer's operation. Each memory represents any combination of memory types, including fast semiconductor memory (e.g., RAM or ROM), slower magnetic memory (e.g., hard disk storage) and optical memory. Each of the computers 240, 220, 202 also includes a processor (not shown) that executes programs in the respective memory 242, 222, 203.

A consumer 104 uses the computer 202 to retrieve content from publishers 106 via the Internet 108. In the memory 203 of the computer 202 is stored a conventional web browser 206 and, optionally, specialized programs 210 that can be used by the consumer 104 to interact with the adaptation service 102. The programs 210 are optional as all
5 consumer 104 interactions with the adaptation service 102 can be via standard Internet programs, such as the browser 206. The illustrated embodiment shows a situation where the representative user 104 intends to use the adapted content 103 on a handheld computer 204 with a limited set of capabilities as compared to the computer 202. It is presumed that the handheld computer 204 does not have Internet access capabilities; therefore, the
10 adapted content 103 is downloaded to the handheld device 204 via the computer 202. In an alternative embodiment where the computer 204 can access and use, in at least a rudimentary manner, Internet content 107, the adapted content 103 can be downloaded directly to the handheld device 204.

15 The handheld computer 204 includes a memory 205 which, as described above, can be any combination of different types of memory. In a typical configuration the memory 205 includes non-volatile memory for long term data storage and RAM for short term data storage and program execution. The memory 205 includes browser/viewer software 208 which is employed by the consumer 104 to use/view the adapted content
20 103 on the handheld device 204. The software 208 can be a novel browser/viewer program or a conventional microviewer/browser for AvantGo, CDF, HTML, XML or other-formatted content. The memory 205 can also include an optional set of capability data 210 indicating characteristics of the handheld device 204, at least some of which are taken into account by the adaptation service 102 when generating the adapted version 103. As
25 described in the co-pending U.S. patent application (Serial No. 09/237,317), the handheld computer can inform the computer 202 and the adaptation service 102 of these capabilities using a universal mobile ID.

30 The capability data 210 can include, but is not limited to, factors such as display resolution (i.e., number of addressable vertical and horizontal pixels), display color depth (i.e., number of bits per pixel) and browser/viewer type. Alternatively, the capability data 210 can be maintained on the consumer computer 202 or on the adaptation service 102.

The configuration shown in FIG. 2 is just one hardware embodiment of the present invention. More generally, the present invention is adaptable to any environment where a consumer 104 with computer resources, including a handheld device 204 and, when the handheld device cannot connect to the Internet 108, a computer 202 with a connection to the Internet, selects Internet content to be adapted for and then downloaded to the handheld device 204. The computer resources can also include resources distributed across the Internet that a consumer can use to fulfill one or more consumer-oriented functions. For example, refer to the alternative embodiments described with reference to FIGS. 5 and 6. In addition to reforming content to work with small form factor devices or devices having limited computing resources, the content configuration performed by the present invention can include, but is not limited to: modifying a site to have a closed, consistent site structure; translating or summarizing site content; or downloading a content package to a user to keep the content current (this could be applied to computer program content or to information content).

A publisher site 106 includes a server 220 that provides content 107 over the Internet 108 in response to user requests 105. The server 220 has a memory 222 that includes publisher server software 228 and web page code 230. In the conventional manner, the server software 228 responds to web page requests 105 transmitted over the Internet from users such as the user 104 by returning the requested pages. The web page code 230 is also conventional in that it represents using standard markup language, such as HTML or eXtensible Markup Language (XML), elements of the publisher's web pages. For example, the code 230a for a particular web page, WP1, includes code for three elements: an adaptation button 232a, element_1 232b and element_2 232c. The adaptation button code 232a, which embodies a novel concept of the present invention, is displayed by the browser 206 as a characteristic widget that indicates that the associated web page WP1 can be adapted for use on the user's handheld device 204. When the adaptation widget is selected by the consumer 104, the underlying adaptation code 232a causes the browser 206 to invoke the adaptation service 102, which subsequently initiates a process by which, in accordance with the present invention, the associated web page is transformed to an adapted version.

The adaptation service 102 includes a server 240 that transforms content 107 from publishers 106 in accordance with user and publisher specifications. The server 240 includes a memory 242 in which is stored adaptation server software 242 and content and user specifications 244, 246. The adaptation server software 242 interacts with publishers 5 106 who wish to provide adapted content 103 and consumers 104 who wish to use the adapted content 103. In particular, the adaptation service software 242 allows publishers to define the specifications 244 pertaining to their content and users to indicate the specifications 246 of their handheld devices 204 used to access the adapted content 103. The adaptation server software 242 also generates in real-time the adapted content 103 10 in accordance with the content and user specifications 244, 246 and, optionally, merges complementary content with the adapted content 103. If specific content and user specifications 244, 246 are not provided by particular publishers 106 and consumers 104, generic settings 244, 246 can be used that are generally appropriate for most web content 107 and handheld devices 204.

15
FIG. 2 shows the situation where two publishers 106 (only one of which is shown) have provided respective content specifications 252a, 252b. Each specification 252 provides a template for transforming a publisher's content in a variety of formats that are not limited to the illustrated formats. For example, the Publisher 1 specification 252a 20 includes approved transformations for elements 1 and 2 254a-1, 254a-2, and web pages (WP) 1 and 2 256a-1, 256a-2. The specification 252a also includes advertisements 258 that can be merged with the adapted content 103 of Publisher 1. Note that complementary content, such as the advertisements 258, need not necessarily be associated with a particular publisher 106 as many different publishers might wish to sell ad space to the same 25 advertisers in the adapted content 103. A series of screen displays illustrating interactions of a consumer 102 with the web page WP1 (corresponding to the web page WP1 of FIG. 2), before and after adaptation processing, is now described with respect to FIGS. 3A-3C.

30 Referring to FIGS. 3A-3C, there are shown diagrams of a sequence of screens presented on the consumer computer 202 (FIG. 2) and on the handheld computer 204 illustrating different stages in a consumer's request for and use of an adapted version of a web page WP1 262. In FIG. 3A, the consumer computer 202 is displaying an un-adapted web page WP1 262, which includes web page elements 266, 268 and a characteristic

adaptation widget 264 that is displayed on any web page that can be transformed by the adaptation service 102. FIG. 3B shows the same screen after the consumer 104 has selected the adaptation widget 264. In response to this selection, an additional adaptation device information window 270 is displayed on which the user can enter attributes of the handheld device on which the adapted content is to be viewed. Alternatively, the user may enter the attributes of the handheld device on the same window as the un-adapted web page WP1 262. In yet another alternative, the user may not need to explicitly enter the characteristics of the handheld, instead relying on protocols (such as the user-agent property of HTTP) that exchange information from which the adaptation service could deduce the device characteristics in some cases.

FIG. 3C shows the adapted web page as it is seen on the display of the handheld computer 202. This display includes transformed versions 266x, 268x of the unadapted elements 266, 268 and complementary advertising 272 merged with the displayed adapted content 103. As described above, the format of and placement on the adapted web page of the adapted elements and complementary content can be determined by any combination of the adaptation server software and the publisher 106 (via the content specification 252), and selected display or viewer/browser-related aspects of the adapted version 103 can be determined by any combination of the user 102 (via the user specification 246) or the adaptation server software 242. A situation has been described where the content adaptation information (i.e., content specifications 244 (FIG. 2)) is provided per page of content; this and other details presented above are merely exemplary and are not intended to limit the scope of the present invention. For example, the present invention also encompasses situations where each of the content specifications 244 is related to a group of content from one or more publishers 106. In another application (called site-structure transformation), the entire structure of a site is transformed so that it is suitable for off-line use. Site-structure transformation is particularly useful as most web content is structured with an endless web of interconnected links, which is not consistent with the closed-world environment of offline use. In particular, the site-structure transformation reorganizes web site structure or eliminates links to create a consistent, closed content set that is suitable for offline use of the web site. A flowchart of actions by the publisher, user and adaptation service are now described with reference to FIG. 4.

Referring to FIG. 4, there is shown a flow diagram illustrating a series of operations performed on the user computer 202, publisher server 220 and adaptation server 240 in the course of adapting Internet content for use by a particular user 102 on a particular type of handheld device 204. Each operation is labeled with an index in parentheses, which is referred to in this discussion. As a first step (2.1) the user 102 selects an adaptation widget 264 on an un-adapted web page 262 displayed on the consumer computer to request an adapted version of the web page 262. The selection of the adaptation widget 264 causes the browser 206 to notify the adaptation server 240 of the selection event (2.2) along with the identity (e.g., publisher, web page URL, etc.) of the web page being viewed when the selection occurred. In response, the adaptation server software 242 processes the notification (2.3) and, because this was the first selection in a particular transaction of the adaptation widget, returns web page code for a window on which the user can enter the characteristics of his or her handheld device (2.4). The user completes the device information on the window (2.5) and again selects the adaptation widget 264 (2.6), which causes the browser 206 to return the user device specifications 246 to the adaptation server 240 (2.7). In response to this second selection of the adaptation widget 264 the adaptation server software 242 generates in real-time the adapted web page 103 corresponding to the web page being viewed on the consumer computer 202 (2.8) and returns that web page to the consumer computer 202 (2.8). Adaptation client software 210 on the consumer computer 202 then downloads the adapted web page 103 to the handheld computer 204 for offline user.

Alternative embodiments of this series of operations are also within the scope of the present invention given the same or different hardware and software. For example, if the handheld computer 204 had rudimentary abilities to use standard web content, it could perform all operations attributed to the consumer computer 202 in the previous description.

In yet another alternative embodiment, if the user has previously registered the characteristics of their handheld device with the adaptation service 102 in the manner described in the cross-referenced U.S. patent application (Serial No. 09/237,317), the steps wherein the user fills in the device information would not be necessary.

In another embodiment, shown in FIG. 5, a downloading session initiated by a consumer session may have an "add to basket" option 310 displayed on a web page 312 (e.g., the web page to be adapted or some other web page) that allows the actual downloading of adapted content 103 to be deferred to a later time and possibly a different device. In this situation, the consumer's computer 202, or the target computer 204 for the downloaded, adapted material 103, can be configured with a client software agent 320 that wakes up and downloads to content added to the basket (or a selected subset) on schedule 324, e.g., during the night. The basket 126 and software agent 320 can be stored/executed on the consumer's devices 202/204 or in whole or in part on another consumer computing resource located on the Internet. The basket is also useful for collecting favorite content of the user in one place so the user doesn't have to hunt around the Web for the content.

In another embodiment, shown in FIG. 6, there is a "library" web site 330 that collects together adapt buttons for a group of content 332. In one embodiment, by pressing a single library adapt button 334, the user/consumer 104 is able to adapt all (or a selected subset) of the content linked into the library 330 as described with reference to FIGS. 3 and 4. Alternatively, the library web site 330 can simply server as a repository of adapt buttons 334a-d associated with individual content pages/sites in lieu of placing adapt buttons 334 on the respective pages/sites. The library web site adapt button(s) could also be configured to allow users to add selected content to the user's personal basket. As shown in FIG. 6, the associated content links 338 are stored on a server 336 associated with the library web site 330. More generally, the adapt button 232 associated with adaptable content does not need to be displayed on the actual content to be adapted - it can be displayed on any other web page or can be included as a link in an e-mail message 337 directed to the consumer. In the e-mail scenario, the consumer 104 can indicate in an e-mail reply 339 to the server 336 the set of content they would like to have adapted. The server 336 in turn will communicate the set of content to be adapted to the adaptation service 102 (which could be co-located with the library site 330).

In another embodiment, shown in FIG. 7, the publisher/content provider 106 can submit content specifications 244 to the adaptation service 102 via e-mail 340. Similarly,

the content provider can receive adaptation information 344 (e.g., diagnostic feedback, adaptation statistics) from the adaptation service 240 (FIG. 2) via e-mail 346.

5 In another embodiment, shown in FIG. 8, the adaptation service 102 can be configured to provide meta-information 350 (i.e., information about information) to the consumer 104 about adaptable content. The meta-information can include, but is not limited to, the size and /or number of pages of the content when adapted 352, results 354 from searches on the content (i.e., the adaptation service can perform searches for consumers 104), multimedia support 356 in the content when adapted, etc. Given this
10 meta-information 350, the consumer 104 is able to decide whether or not they wish to proceed to download the adapted content.

Additionally, it has been disclosed that the adapted content 103 can be provided to the user 104 via a web-based interface. More generally, adapted content 103 can be
15 consumed by a user 104 via e-mail or any other type of electronic interface capable of delivering information to a consumer 104. In other embodiments, the content can be sourced from the publisher to the adaptation service via an equivalent range of electronic interfaces, including FTP and e-mail. Finally, in addition to the type of content adaptation already described, the range of adaptations that can be implemented within the context
20 of the present invention can include, but is not limited to: language translation, content condensation/summarization and any other type of content transformation that is based on configuration information/content specification 244 (FIG. 2) provided by a publisher 106.

25 While the present invention has been described with reference to a few specific embodiments, the description is illustrative of the invention and is not to be construed as limiting the invention. Various modifications may occur to those skilled in the art without departing from the true spirit and scope of the invention as defined by the appended claims. All patents and publications referenced herein are hereby incorporated by reference.

30

WHAT IS CLAIMED IS:

1. An operating model for an Internet-based, content adaptation service, comprising:
a publisher who provides Internet content;
a consumer with computing resources, including a handheld device employed by
5 the consumer to use an adapted version of the Internet content;
an adaptation server configured to transform the Internet content to the adapted
version for use by the consumer on the handheld device, wherein the adapted version is
formatted so as to be compatible with capabilities of the handheld device and content
transformation specifications of the publisher indicating preferences of the publisher
10 regarding characteristics of the adapted version.
2. The operating model of claim 1, wherein the computer resources further comprise
an Internet-connected computer, such that, when the handheld device does not have an
Internet connection, the consumer downloads the adapted version to the handheld device
15 via the Internet-connected computer.
3. The operating model of claim 1, wherein the adapted version is usable when the
handheld device is not connected to the Internet.
- 20 4. The operating model of claim 1, wherein the Internet content comprises a
characteristic symbol indicating that the Internet content is adaptable, such that, when the
consumer selects the characteristic symbol while using the Internet content, a dialog
window is presented to the consumer wherein the consumer can indicate the capabilities
of the handheld device, the capabilities being returned to the adaptation server for use in
25 transforming the Internet content into the adapted content.
5. The operating model of claim 4, wherein the capabilities are returned to the
adaptation server when the consumer selects the characteristic symbol for a second time.
- 30 6. The operating model of claim 1, wherein the adaptation server comprises a memory
programmed with the transformation specification.

7. The operating model of claim 6, wherein the adaptation server is configured to create the transformation specification from input provided by the publisher.

5 8. The operating model of claim 6, wherein the memory is further programmed with advertising content to be merged with the adapted content returned by the adaptation server to the user in accordance with rules provided by the publisher.

9. The operating model of claim 1, wherein the adapted version is at least one of:
10 an alternative version of the Internet content with reduced size;
an alternative version of the Internet content with reduced multimedia content;
a translation of the Internet content;
a summary/condensation of the Internet content; and
a site structure transformation including an alternative version of the Internet content
with fewer pages or altered link structure.

15 10. The operating model of claim 1, wherein:
the computing resources comprise a personal shopping basket and client agent
software;
the Internet content, when displayed by the computing resources, is associated with
20 an add to basket button that, when selected by the consumer, causes a link to the Internet
content to be added to the personal shopping basket; and
the client agent software is configured to download the adapted versions of at least
a subset of the Internet content whose links are in the personal shopping basket.

25 11. The operating model of claim 1, wherein the adapted versions are downloaded according to a schedule stored in the computing resources.

12. The operating model of claim 1, further comprising:
a library web site that collects adapt buttons for a group of the Internet content;
30 wherein:
the library web site, when displayed by the computing resources, is associated with
one or more library adapt buttons that, when selected by the consumer, cause the adapted

versions of at least a subset of the group of the Internet content to be downloaded for use on the handheld device.

- 5 13. The operating model of claim 12, wherein the one or more library adapt buttons, when selected by the consumer, further allow at least a second subset of the group of the Internet content to be added to a personal basket for subsequent downloading.
- 10 14. The operating model of claim 1, wherein adaptation information regarding status of adaptation of the Internet content is forwarded by the adaptation service to the publisher and content transformation specifications are forwarded by the publisher to the adaptation service via any combination of: Internet-based services.
- 15 15. The operating model of claim 1, wherein the adaptation service is a pure web-based service that can be accessed by the publisher and the consumer without installing any special-purpose software associated with the adaptation service.
- 20 16. The operating model of claim 1, wherein the adaptation service is configured to provide to the consumer meta-information about the Internet content prior to downloading of the adapted version by the user;
- 25 17. The operating model of claim 16, wherein the meta-content comprises at least one of:
size of the adapted version;
search results on the adapted version; and
level of multimedia support provided by the adapted version.
18. The operating model of claim 1, wherein the content adaptation service transforms the Internet content into the adapted version only upon request.
- 30 19. The operating model of claim 1, wherein the characteristics comprise appearance of the adapted version.

20. An operating method for an Internet-based, content adaptation service, comprising:
transforming Internet content to an adapted version for use on a handheld device;
and

5 formatting the adapted version so as to be compatible with capabilities of the
handheld device and content transformation specifications of a provider of the Internet
content indicating preferences of the publisher regarding characteristics of the adapted
version.

10 21. The operating method of claim 20, wherein the transforming of the Internet content
into the adapted version is performed only upon request.

22. The operating method of claim 20, wherein the characteristics comprise appearance
of the adapted version.

15 23. The operating method of claim 20, wherein the transforming comprises at least
one of:

reducing size and multimedia content of the Internet content;

translating the Internet content from one language to another language;

summarizing the Internet content; and

20 transforming site structure of the Internet content by reducing pages or altering
link structure thereof.

24. The operating method of claim 20, further comprising:
creating the transformation specification from input provided by the publisher.

25 25. The operating model of claim 20, further comprising:
merging the adapted content returned by the adaptation server with advertising
content in accordance with rules provided by the publisher.

30 26. The operating method of claim 20, further comprising:
displaying the Internet content with an add to basket button;
adding a link to the Internet content to a personal shopping basket of the consumer
upon selection by the consumer of the add to basket button; and

downloading the adapted versions of at least a subset of the Internet content whose links are in the personal shopping basket.

- 5 27. The operating model of claim 26, wherein downloading the adapted versions linked in the personal shopping basket comprises downloading the adapted versions according to a schedule.
- 10 28. The operating method of claim 20, further comprising:
collecting at a single library site adapt buttons for a group of the Internet content.
29. The operating method of claim 20, further comprising:
providing the consumer meta-information about the Internet content prior to downloading of the adapted version by the user.
- 15 30. A business method for an Internet based content adaptation service, comprising:
a publisher with Internet content it wishes to make available to users of handheld devices;
an adaptation service hosted on the Internet that provides a pure, web-based interface via which the publisher can specify characteristics of an adapted version of the Internet
20 content for use on the handheld devices, the adaptation service being configured to transform the Internet content to the adapted version in accordance with the publisher-specified characteristics.
- 25 31. The business method of claim 30, wherein the adaptation service is configured to obtain permission from the publisher to transform the Internet content.
32. The business method of claim 30, wherein the adaptation service is configured to transform the Internet content upon request.
- 30 33. The business method of claim 30, wherein the adaptation service is further configured to transform the Internet content to the adapted version in accordance with user-specified handheld device characteristics.

34. The business method of claim 33, further comprising a pure web-based user interface whereby the user enters the user-specified handheld device characteristics.

35. The business method of claim 34, wherein the user-specified handheld device characteristics comprise at least one of: display resolution; display color depth; and browser type.

36. The business method of claim 33, further comprising a pure web-based user interface whereby the user-specified handheld device characteristics are deduced from information exchanged with the adaptation service.

37. An operating model for an Internet-based, content adaptation service, comprising:
a publisher who provides Internet content;

a consumer with computing resources, including a information device employed by the consumer to use an adapted version of the Internet content; and

an adaptation server configured to transform the Internet content to the adapted version for use by the consumer on the information device, wherein the adapted version is formatted so as to be compatible with capabilities of the information device and content transformation specifications of the publisher indicating preferences of the publisher regarding characteristics of the adapted version.

38. The operating model of claim 37, wherein the computer resources further comprise an Internet-connected computer, such that, when the information device does not have an Internet connection, the consumer downloads the adapted version to the information device via the Internet-connected computer.

39. The operating model of claim 37, wherein the adapted version is usable when the information device is not connected to the Internet.

40. The operating model of claim 37, wherein the Internet content comprises a characteristic symbol indicating that the Internet content is adaptable, such that, when the consumer selects the characteristic symbol while using the Internet content, a dialog window is presented to the consumer wherein the consumer can indicate the capabilities

of the information device, the capabilities being returned to the adaptation server for use in transforming the Internet content into the adapted content.

5 41. A business method for an Internet based content adaptation service, comprising:
a publisher with Internet content it wishes to make available to users of information devices;

an adaptation service hosted on the Internet that provides a pure, web-based interface via which the publisher can specify characteristics of an adapted version of the Internet content for use on the information devices, the adaptation service being configured to
10 transform the Internet content to the adapted version in accordance with the publisher-specified characteristics.

15 42. The business method of claim 41, wherein the adaptation service is configured to obtain permission from the publisher to transform the Internet content.

43. The business method of claim 41, wherein the adaptation service is configured to transform the Internet content upon request.

20 44. The business method of claim 41, wherein the adaptation service is further configured to transform the Internet content to the adapted version in accordance with user-specified information device characteristics.

25 45. The business method of claim 44, further comprising a pure web-based user interface whereby the user enters the user-specified information device characteristics.

46. A an Internet-based content adaptation system, comprising:
a first computer receiving Internet content from a content publisher;
coumputer resources including an information appliance employed by a consumer
to use an adapted version of the Internet content;

30 an adaptation server configured to transform the Internet content to the adapted version for use by the consumer on the computer resources, wherein the adapted version is formatted so as to be compatible with capabilities of the information appliance and

content transformation specifications of the publisher indicating preferences of the publisher regarding characteristics of the adapted version.

5 47. The system of claim 46, wherein the computer resources further comprise an Internet-connected computer, such that, when the information appliance does not have an Internet connection, the consumer downloads the adapted version to the information appliance via the Internet-connected computer.

10 48. The system of claim 46, wherein the adapted version is usable when the handheld device is not connected to the Internet.

15 49. The system of claim 46, wherein the Internet content comprises a characteristic symbol indicating that the Internet content is adaptable, such that, when the consumer selects the characteristic symbol while using the Internet content, a dialog window is presented to the consumer wherein the consumer can indicate the capabilities of the handheld device, the capabilities being returned to the adaptation server for use in transforming the Internet content into the adapted content.

20 50. The operating model of claim 49, wherein the capabilities are returned to the adaptation server when the consumer selects the characteristic symbol for a second time.

51. The system of claim 46, wherein the adaptation server comprises a memory programmed with the transformation specification.

25 52. The system of claim 51, wherein the adaption server is configured to create the transformation specification from input provided by the publisher.

30 53. The system of claim 51, wherein the memory is further programmed with advertising content to be merged with the adapted content returned by the adaptation server to the user in accordance with rules provided by the publisher.

54. The system of claim 46, wherein the adapted version is at least one of:
an alternative version of the Internet content with reduced size;

an alternative version of the Internet content with reduced multimedia content;
a translation of the Internet content;
a summary/condensation of the Internet content; and
a site structure transformation including an alternative version of the Internet content
5 with fewer pages or altered link structure.

55. The system of claim 46, wherein:

the computing resources comprise a personal shopping basket and client agent
software;

10 the Internet content, when displayed by the computing resources, is associated with
an add to basket button that, when selected by the consumer, causes a link to the Internet
content to be added to the personal shopping basket; and

the client agent software is configured to download the adapted versions of at least
a subset of the Internet content whose links are in the personal shopping basket.

15

56. The system of claim 46, wherein the adapted versions are downloaded according
to a schedule stored in the computing resources.

57. The system of claim 46, further comprising:

20 a library web site that collects adapt buttons for a group of the Internet content;
wherein:

the library web site, when displayed by the computing resources, is associated with
one or more library adapt buttons that, when selected by the consumer, cause the adapted
versions of at least a subset of the group of the Internet content to be downloaded for use
25 on the handheld device.

25

58. The system of claim 57, wherein the one or more library adapt buttons, when
selected by the consumer, further allow at least a second subset of the group of the Internet
content to be added to a personal basket for subsequent downloading.

30

59. The system of claim 46, wherein adaptation information regarding status of
adaptation of the Internet content is forwarded by the adaptation service to the publisher

and content transformation specifications are forwarded by the publisher to the adaptation service via any combination of Internet-based services.

5 60. The system of claim 46, wherein the adaptation service is a pure web-based service that can be accessed by the publisher and the consumer without installing any special-purpose software associated with the adaptation service.

10 61. The system of claim 46, wherein the adaptation service is configured to provide to the consumer meta-information about the Internet content prior to downloading of the adapted version by the user;

15 62. The system of claim 61, wherein the meta-content comprises at least one of:
size of the adapted version;
search results on the adapted version; and
level of multimedia support provided by the adapted version.

63. The system of claim 46, wherein the content adaptation service transforms the Internet content into the adapted version only upon request.

20 64. The system of claim 46, wherein the characteristics comprise appearance of the adapted version.

AMENDED CLAIMS

[received by the International Bureau on 02 December 2000 (02.12.00);
original claims 7 amended;
remaining claims unchanged (1 page)]

7. The operating model of claim 6, wherein the adaption server is configured to create the transformation specification from said preferences of the publisher regarding characteristics of the adapted version input by the publisher.
8. The operating model of claim 6, wherein the memory is further programmed with advertising content to be merged with the adapted content returned by the adaptation server to the user in accordance with rules provided by the publisher.
9. The operating model of claim 1, wherein the adapted version is at least one of:
an alternative version of the Internet content with reduced size;
an alternative version of the Internet content with reduced multimedia content;
a translation of the Internet content;
a summary/condensation of the Internet content; and
a site structure transformation including an alternative version of the Internet content with fewer pages or altered link structure.
10. The operating model of claim 1, wherein:
the computing resources comprise a personal shopping basket and client agent software;
the Internet content, when displayed by the computing resources, is associated with an add to basket button that, when selected by the consumer, causes a link to the Internet content to be added to the personal shopping basket; and
the client agent software is configured to download the adapted versions of at least a subset of the Internet content whose links are in the personal shopping basket.
11. The operating model of claim 1, wherein the adapted versions are downloaded according to a schedule stored in the computing resources.
12. The operating model of claim 1, further comprising:
a library web site that collects adapt buttons for a group of the Internet content;
wherein:
the library web site, when displayed by the computing resources, is associated with one or more library adapt buttons that, when selected by the consumer, cause the adapted

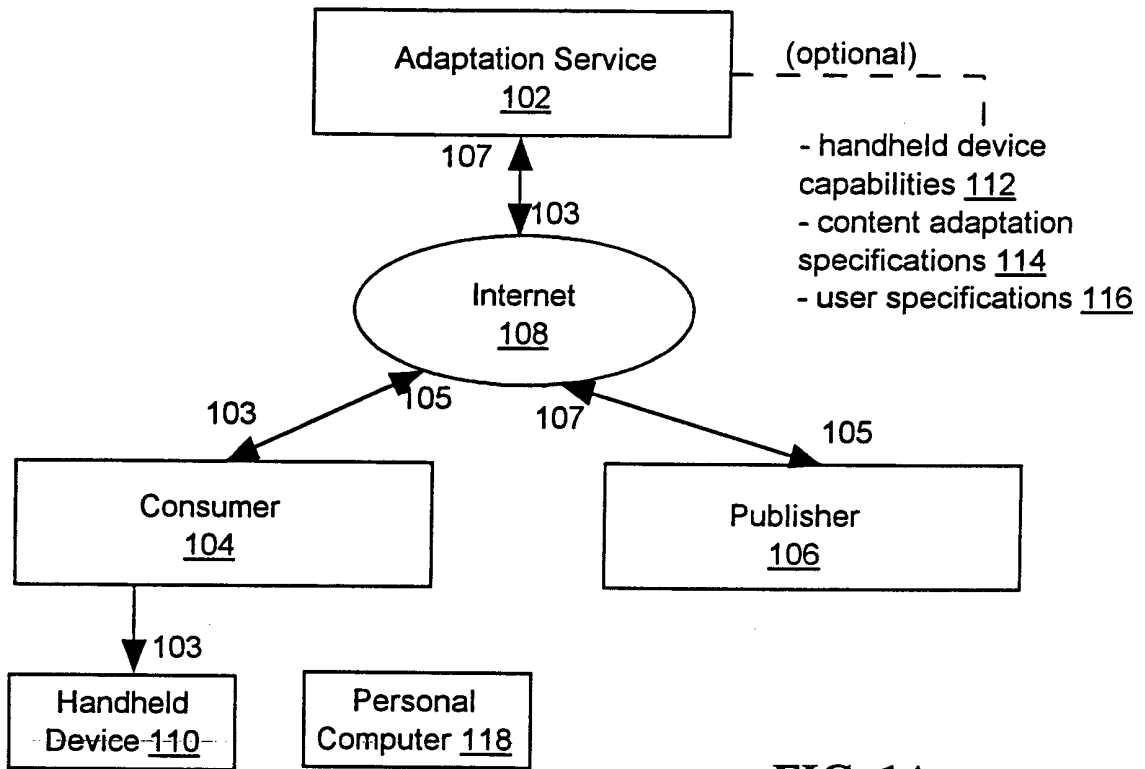

FIG. 1A

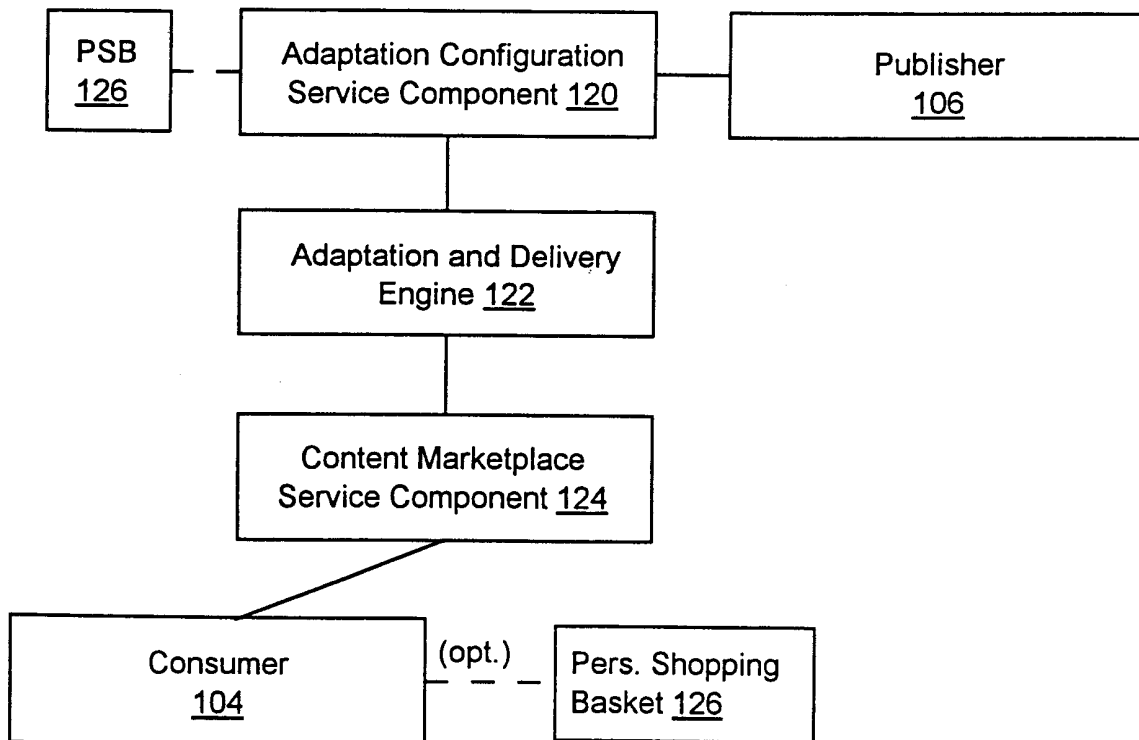

FIG. 1B

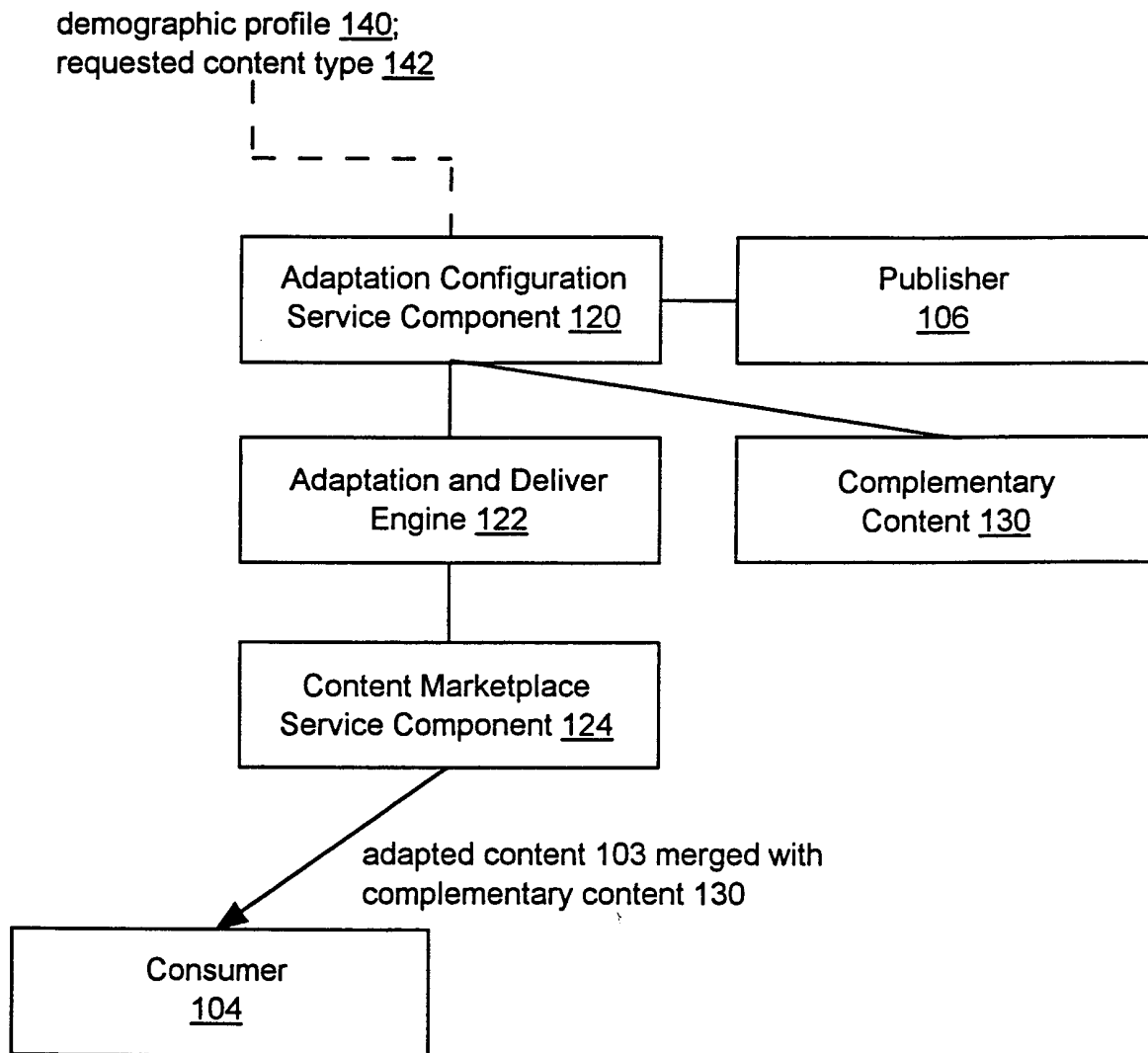

FIG. 1C

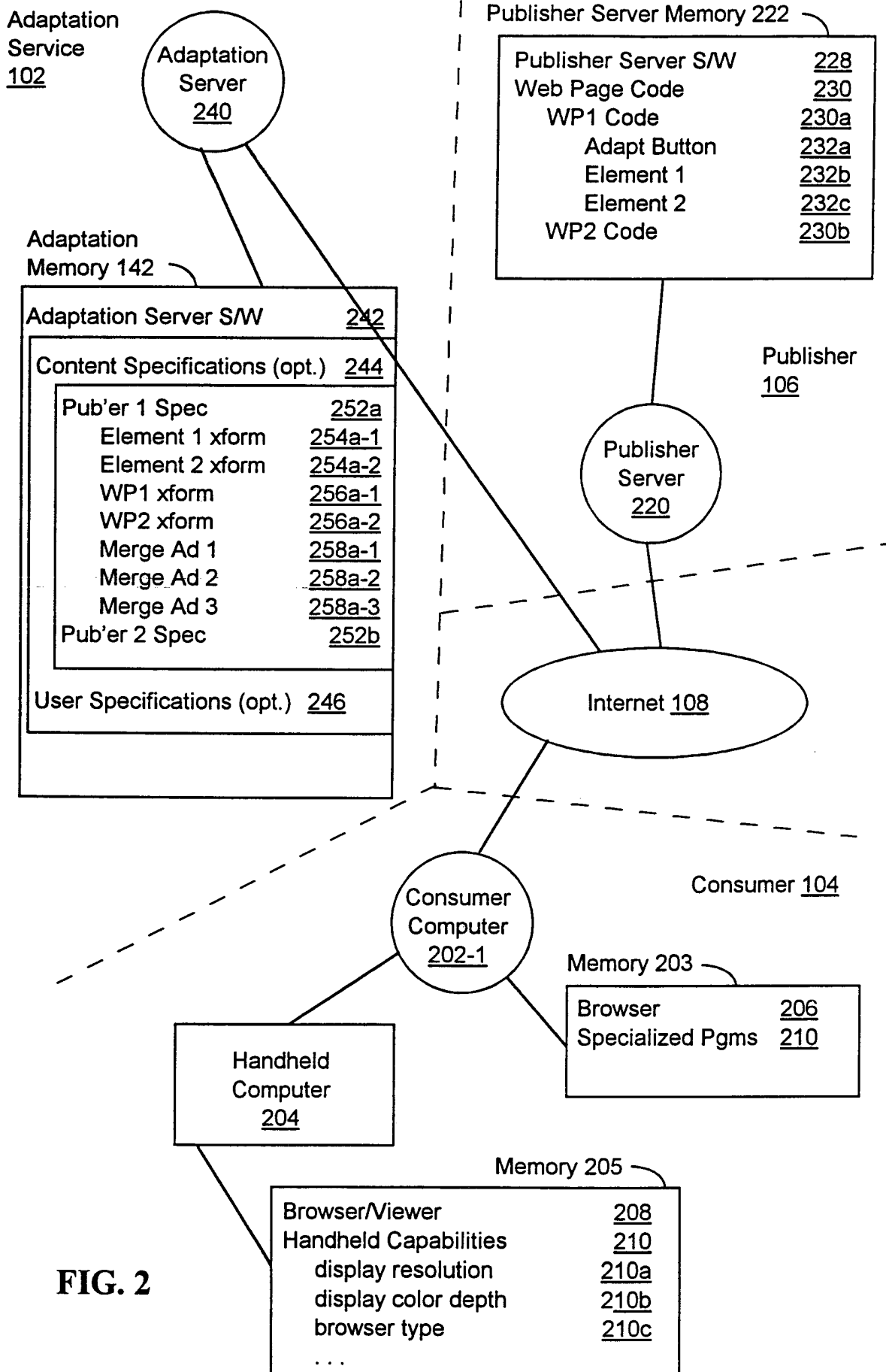

FIG. 2

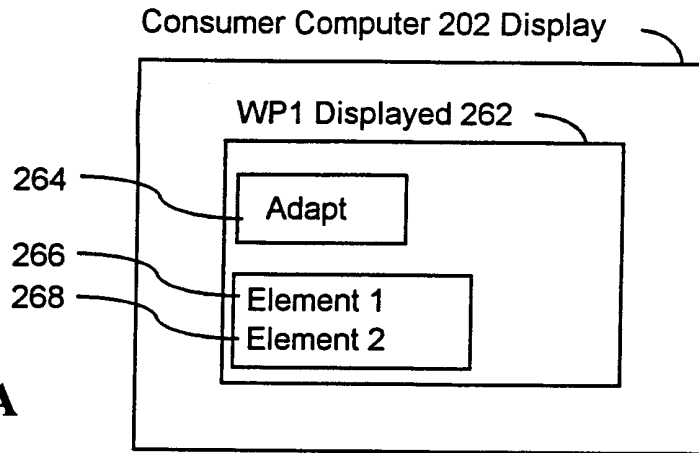

FIG. 3A

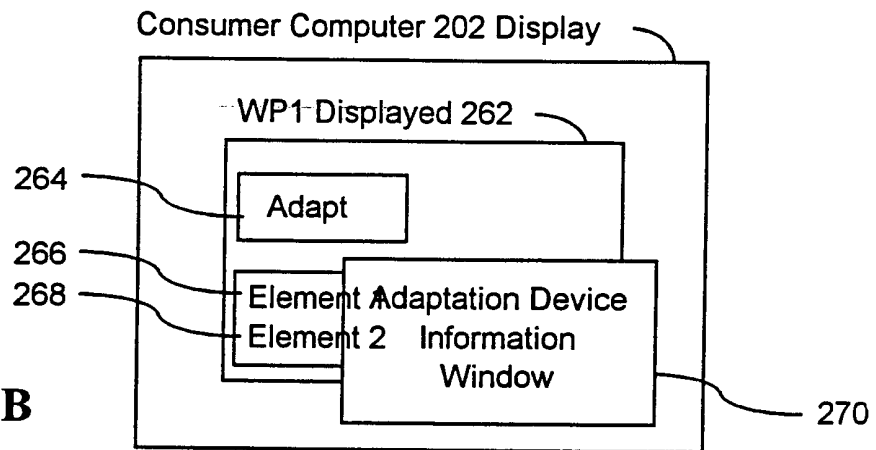

FIG. 3B

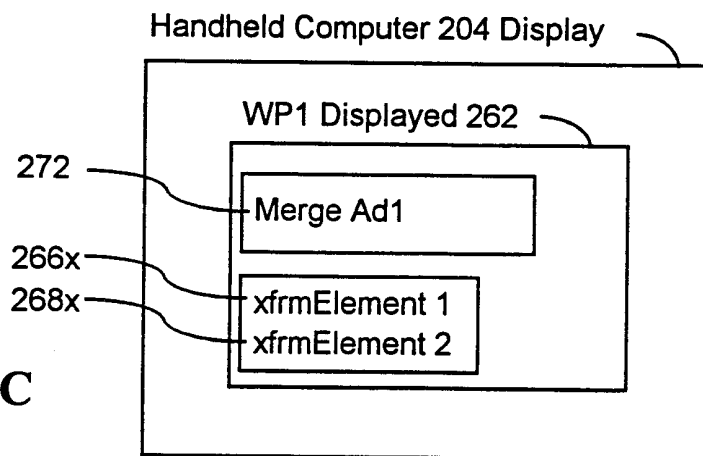

FIG. 3C

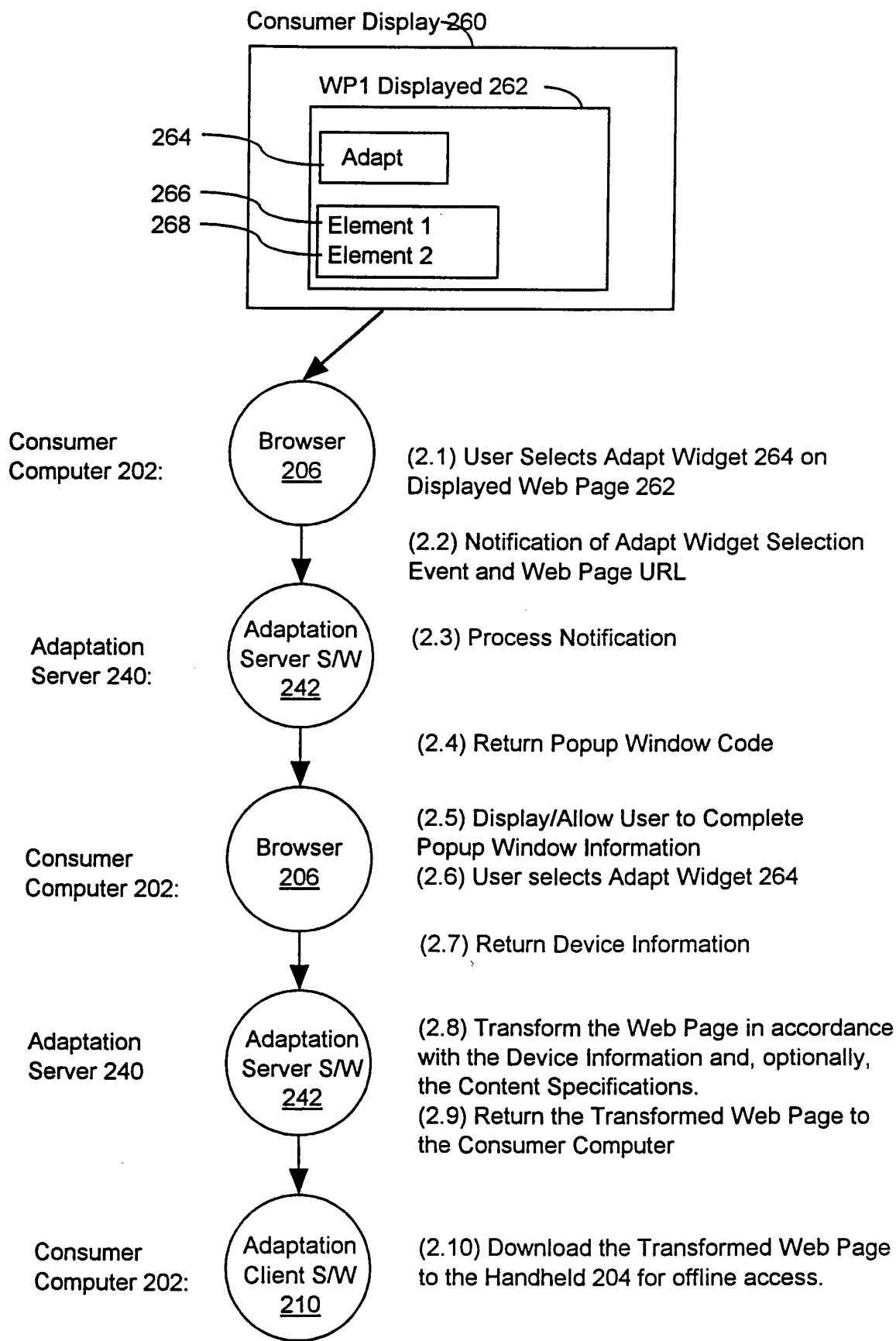

FIG. 4

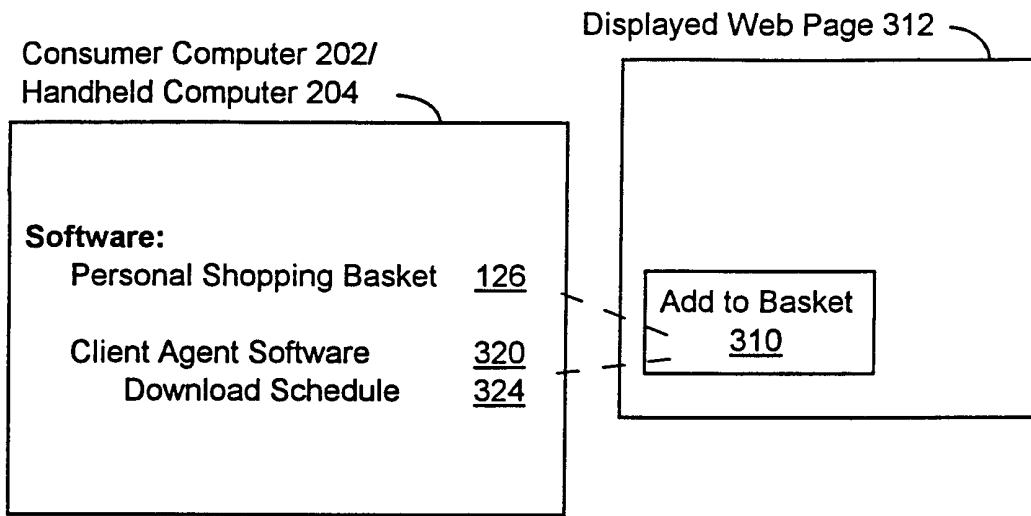

FIG. 5

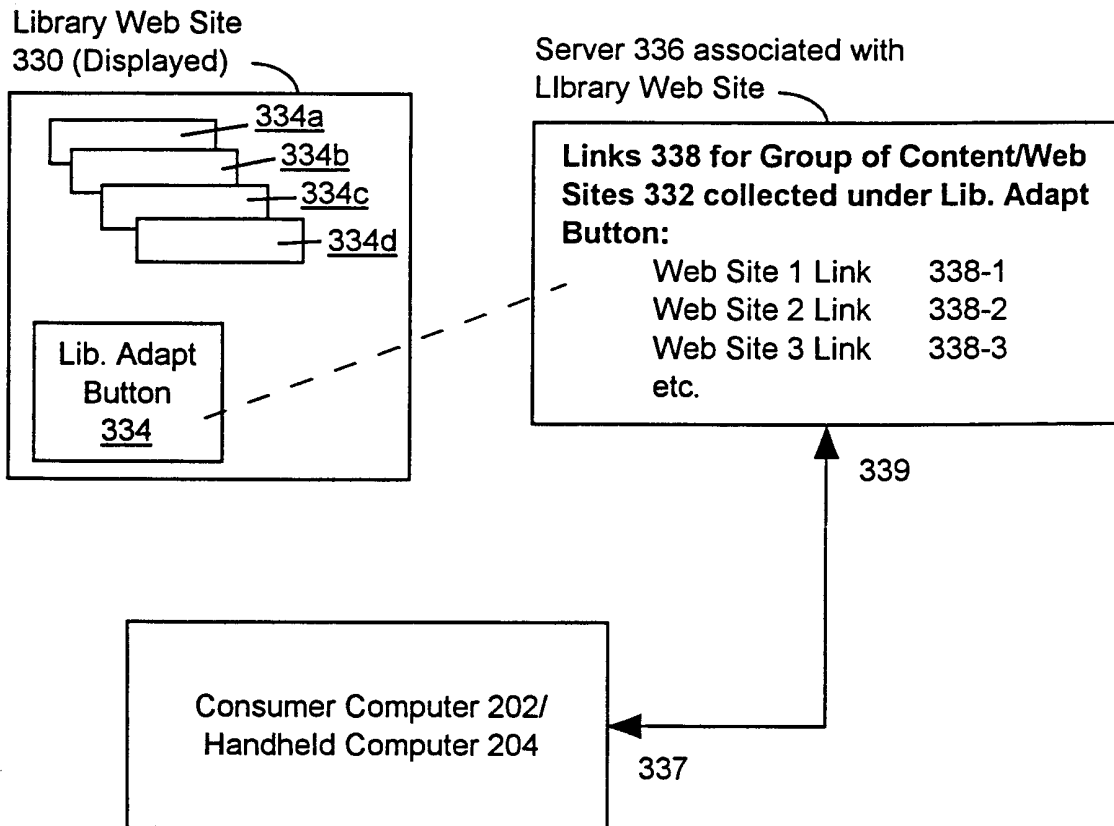

FIG. 6

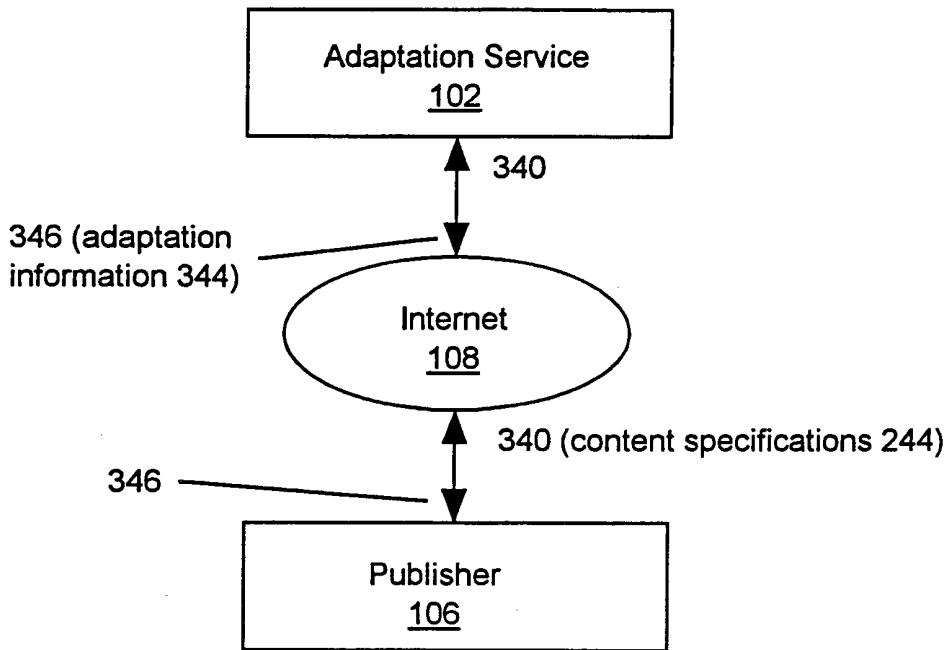

FIG. 7

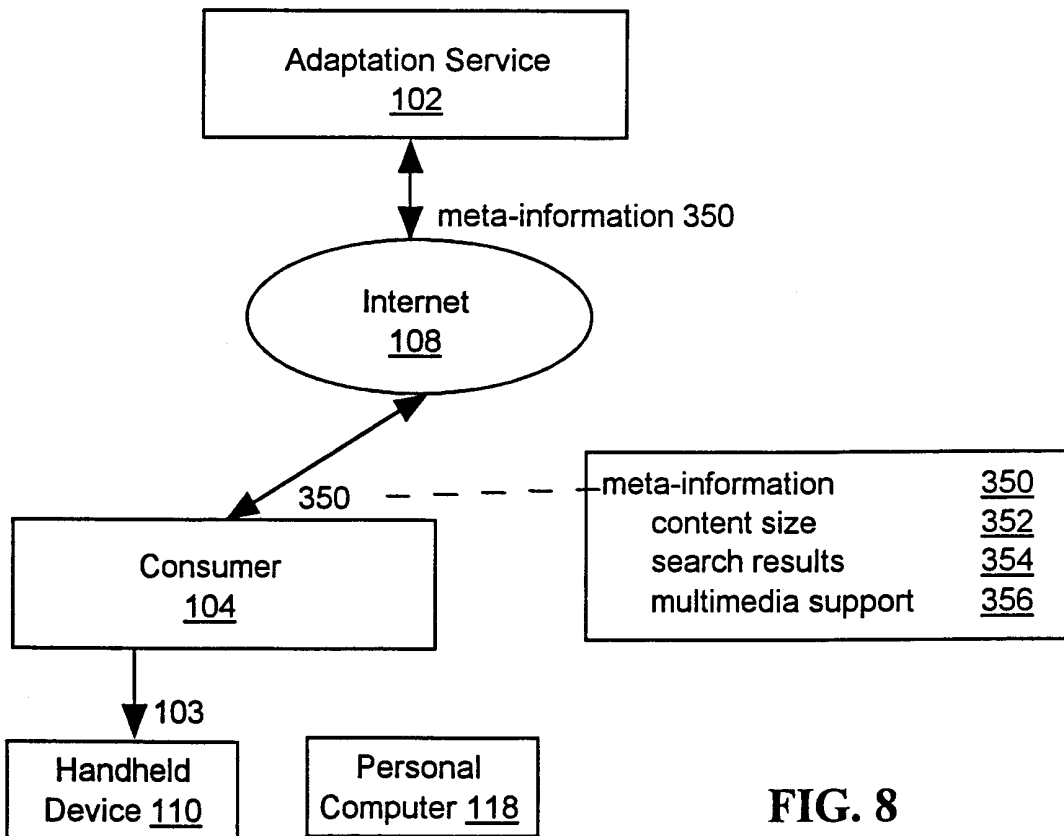

FIG. 8

INTERNATIONAL SEARCH REPORT

International application No.
PCT/US00/17269

A. CLASSIFICATION OF SUBJECT MATTER IPC(7) :G06F 15/16, 15/173 US CL :709/217, 226, 227, 246 According to International Patent Classification (IPC) or to both national classification and IPC		
B. FIELDS SEARCHED		
Minimum documentation searched (classification system followed by classification symbols) U.S. : 709/217, 226, 227, 246		
Documentation searched other than minimum documentation to the extent that such documents are included in the fields searched		
Electronic data base consulted during the international search (name of data base and, where practicable, search terms used) ACM search terms: web page PDA content		
C. DOCUMENTS CONSIDERED TO BE RELEVANT		
Category*	Citation of document, with indication, where appropriate, of the relevant passages	Relevant to claim No.
Y	US 5,727,159 A (KIKINIS) 10 March 1998, whole document.	1-64
Y	FOX. A. Adapting to network and client variability via on-demand dynamic distillation ACM Architectural Support for Programming Languages and Operating Systems. October 1996. pages 160-170, especially page 169.	1-64
Y	US 5,911,776 A (GUCK) 15 June 1999, whole document.	7, 18, 21, 24, 32, 41-45
A	US 5,887,133 (BROWN et al) 23 March 1999, whole document.	10-12, 34, 43
<input type="checkbox"/> Further documents are listed in the continuation of Box C. <input type="checkbox"/> See patent family annex.		
* *A* *E* *L* *O* *P*	Special categories of cited documents: document defining the general state of the art which is not considered to be of particular relevance earlier document published on or after the international filing date document which may throw doubts on priority claim(s) or which is cited to establish the publication date of another citation or other special reason (as specified) document referring to an oral disclosure, use, exhibition or other means document published prior to the international filing date but later than the priority date claimed	*T* *X* *Y* *&*
Date of the actual completion of the international search 10 SEPTEMBER 2000		Date of mailing of the international search report 03 OCT 2000
Name and mailing address of the ISA/US Commissioner of Patents and Trademarks Box PCT Washington, D.C. 20231 Facsimile No. (703) 305-3230		Authorized officer MICHAEL RAZAVI <i>James R. Matthews</i> Telephone No. (703) 305-3900