

(12) UK Patent

(19) GB

(11) 2628262

(13) B

(45) Date of B Publication

16.04.2025

(54) Title of the Invention: **A water heater**

(51) INT CL: **F24H 9/20** (2022.01)      **F24H 15/31** (2022.01)      **G05D 7/00** (2006.01)

(21) Application No: **2408772.8**

(22) Date of Filing: **07.10.2020**

Date Lodged: **18.06.2024**

(62) Divided from Application No  
**2015863.0** under section 15(9) of the Patents Act 1977

(43) Date of A Publication **18.09.2024**

(72) Inventor(s):  
**Keith Alan Hart**  
**Mark Hopkins**

(73) Proprietor(s):  
**Norcros Group (Holdings) Limited**  
**Ladyfield House, Station Road, Wilmslow, Cheshire,**  
**SK9 1BU, United Kingdom**

(74) Agent and/or Address for Service:  
**Forresters IP LLP**  
**Rutland House, 148 Edmund Street, BIRMINGHAM,**  
**B3 2JA, United Kingdom**

(56) Documents Cited:

**GB 2341667 A**                      **GB 2232274 A**  
**GB 2103391 A**                      **US 20060202141 A1**

(58) Field of Search:

As for published application 2628262 A viz:  
INT CL **F16K, F24H, G05D**  
Other: **WPI, EPODOC, Patent Fulltext**  
updated as appropriate

Additional Fields  
Other: **SEARCH-PATENT**

GB 2628262 B

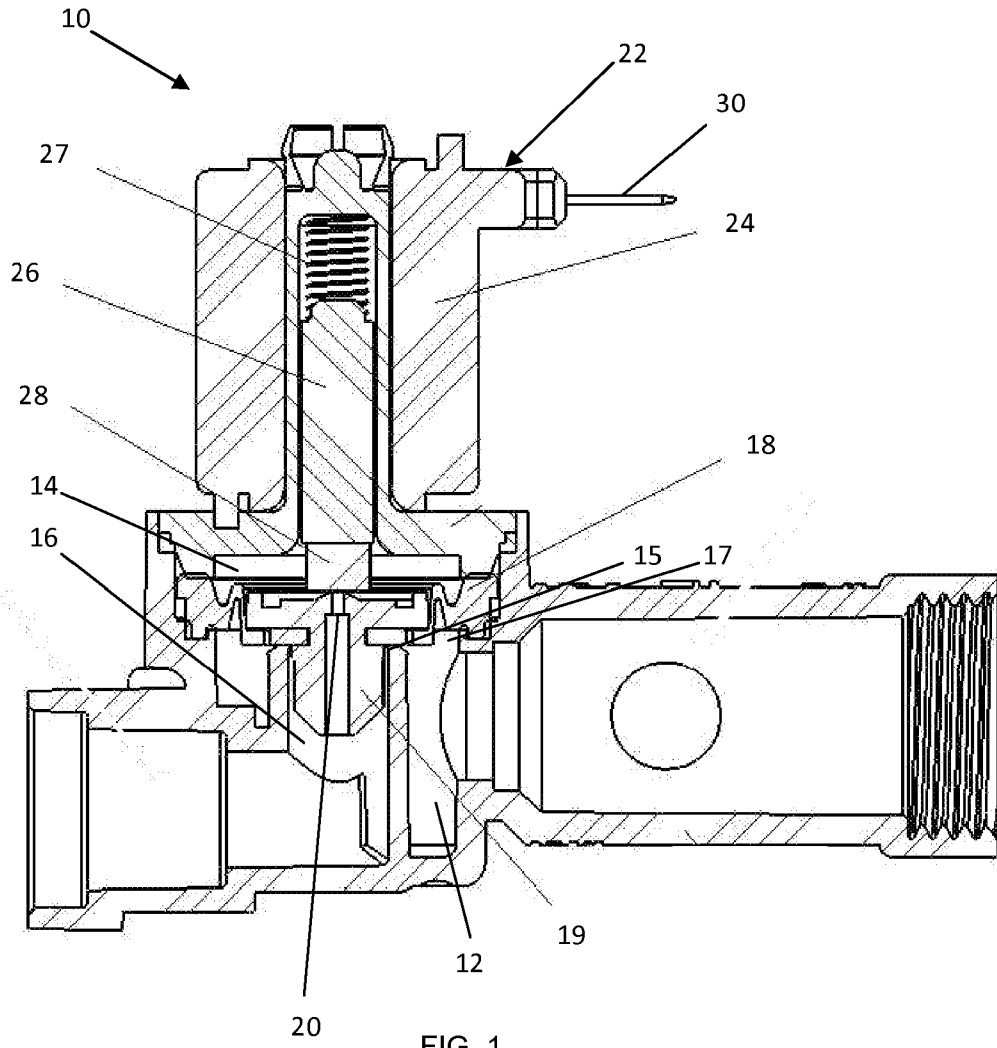

09 07 24

09 07 24

2 / 10

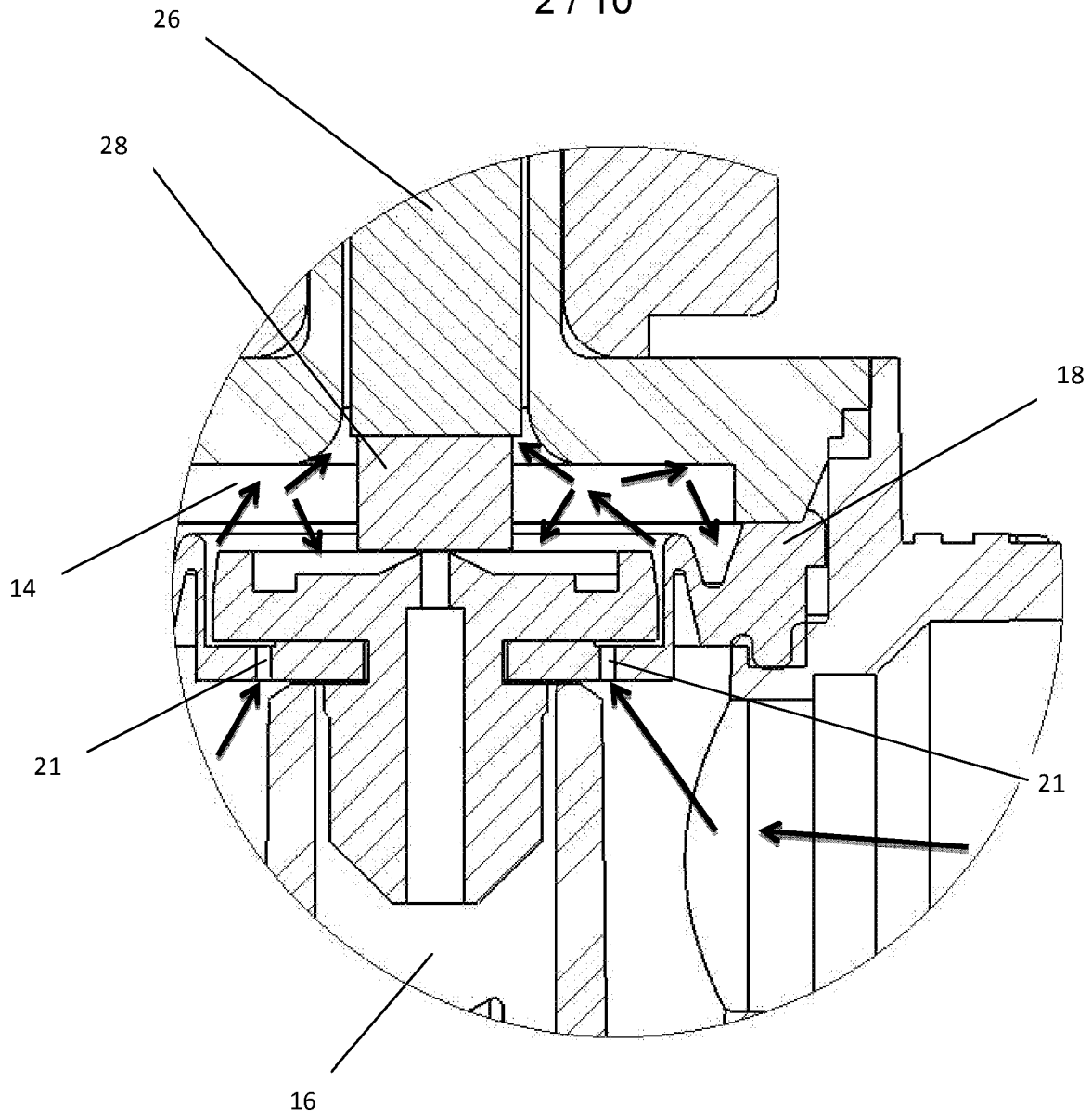

FIG. 2

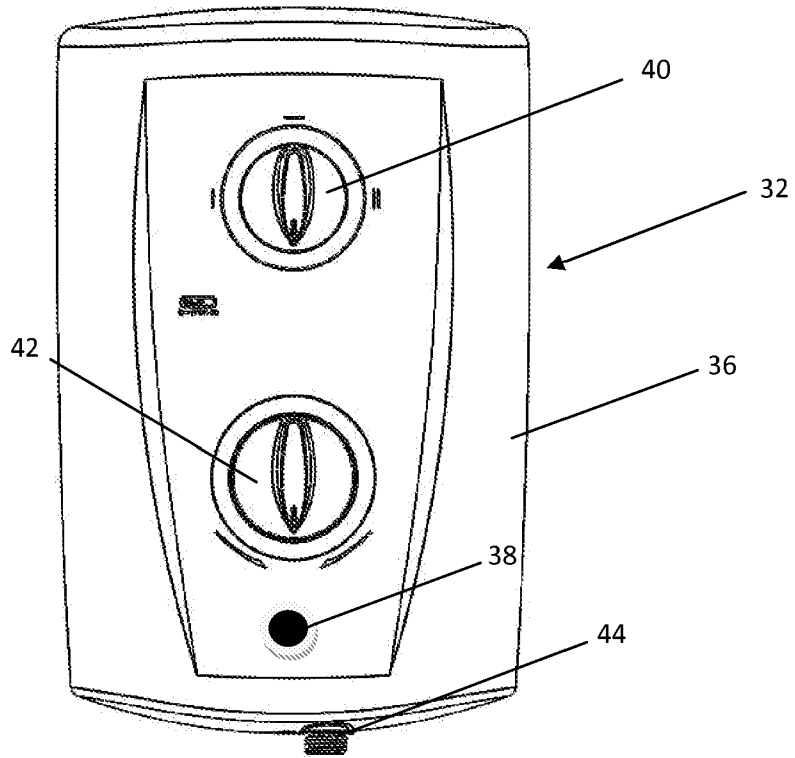

Fig. 3

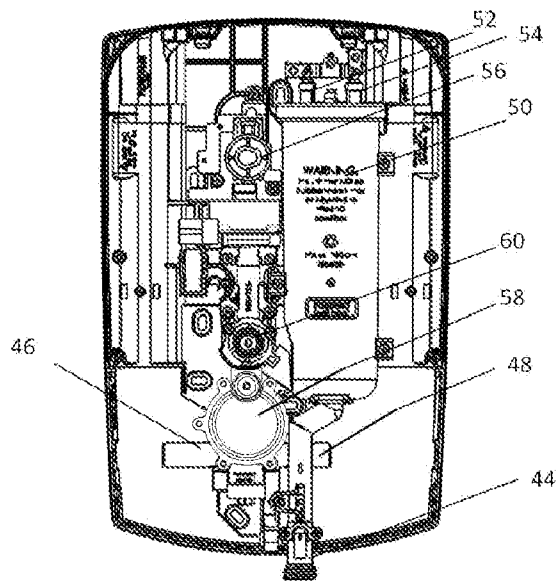

Fig. 4

09 07 24

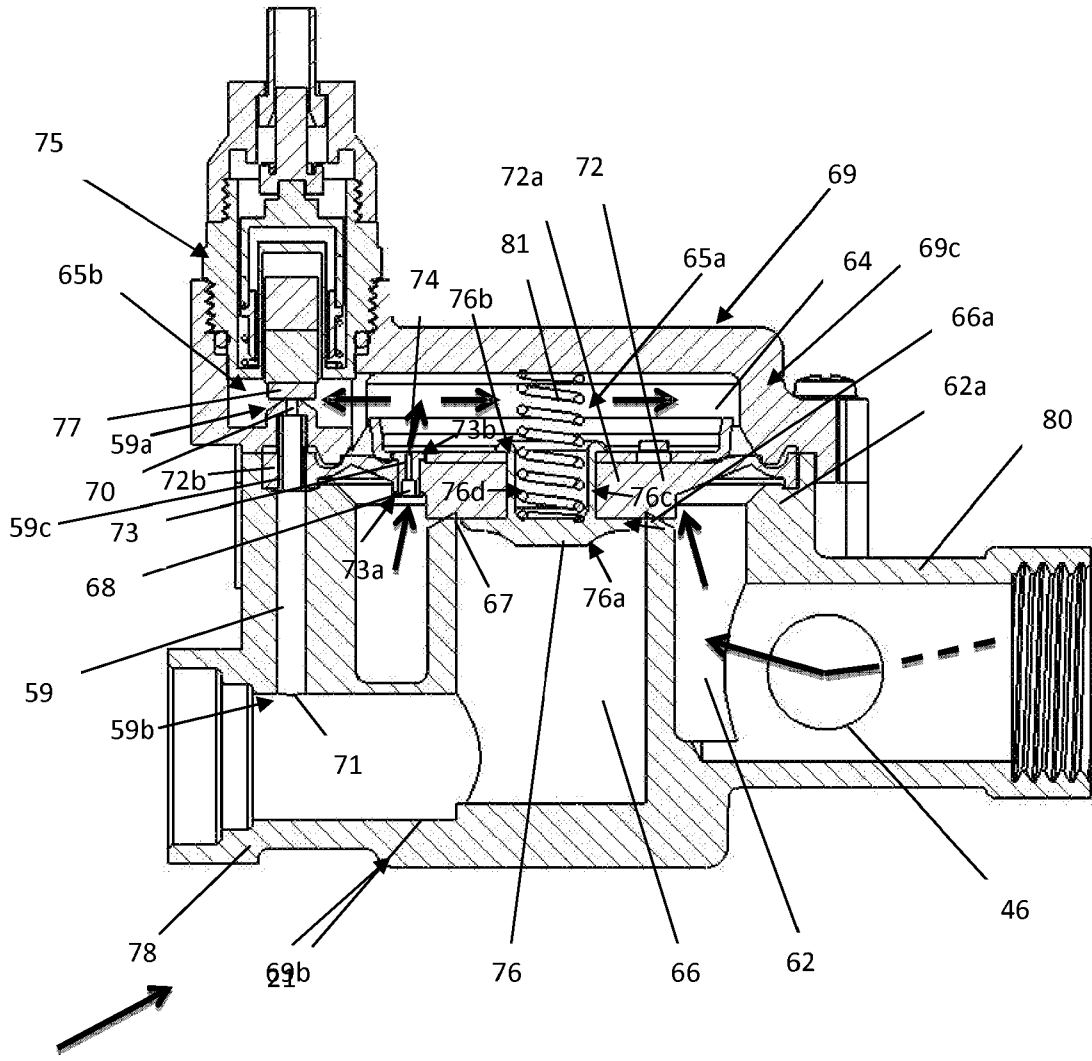

Fig.5

09 07 24

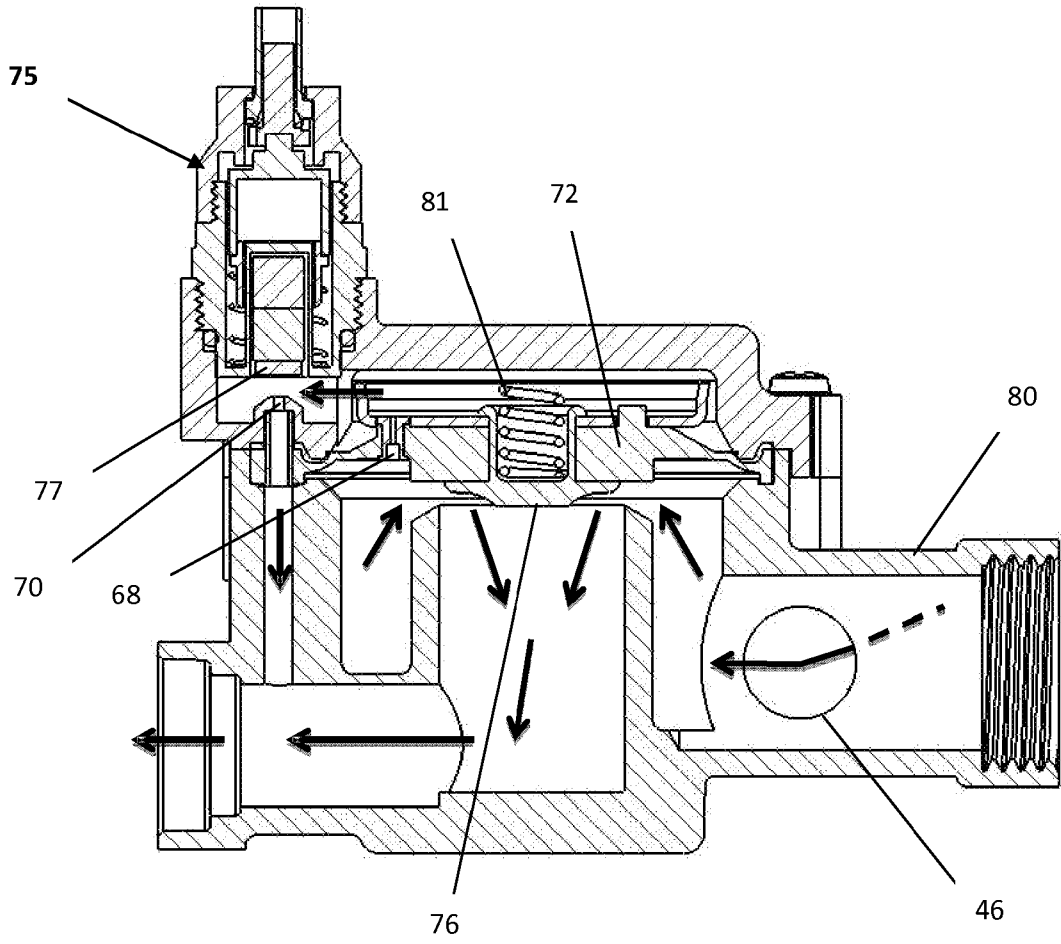

Fig.6

09 07 24

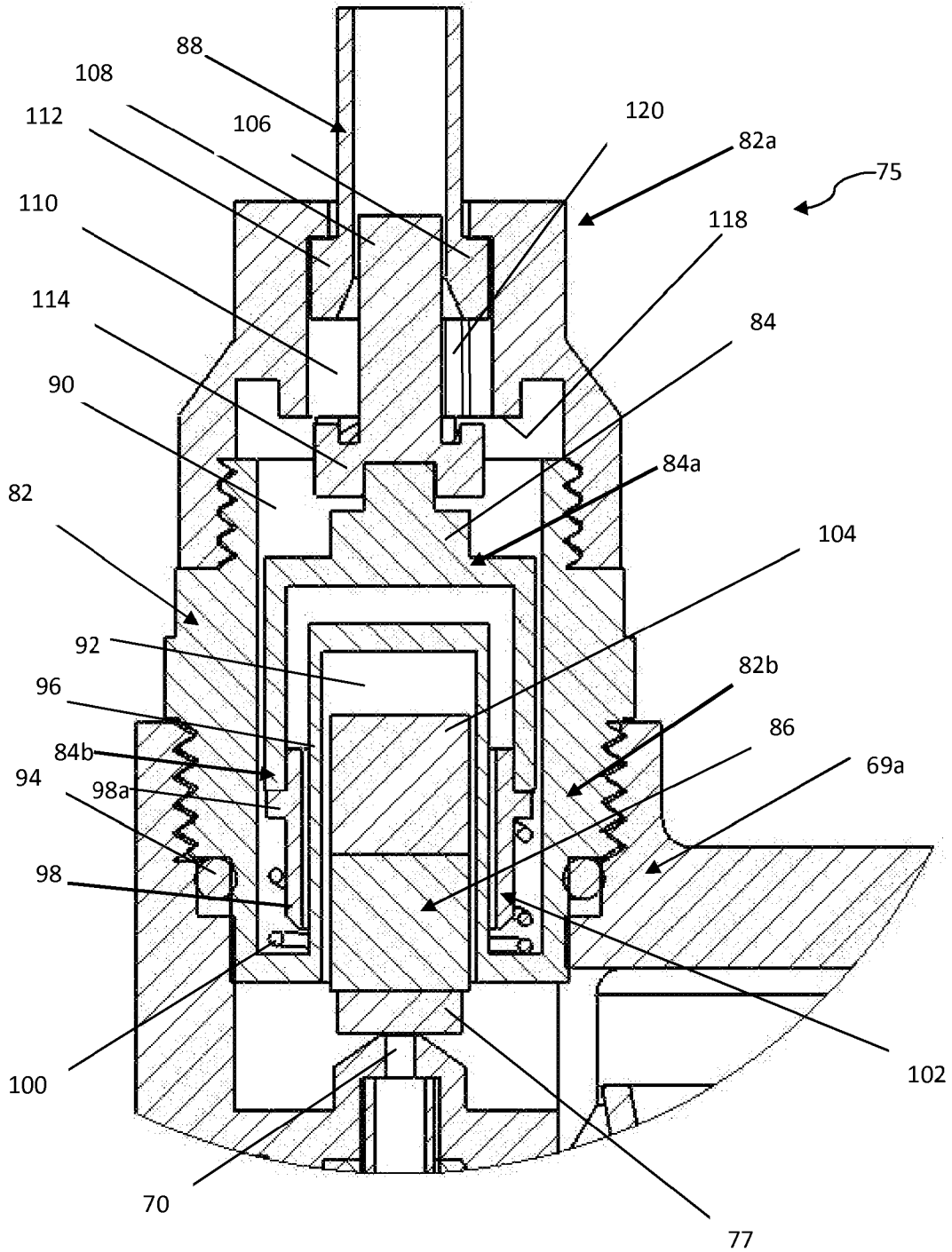

Fig. 7

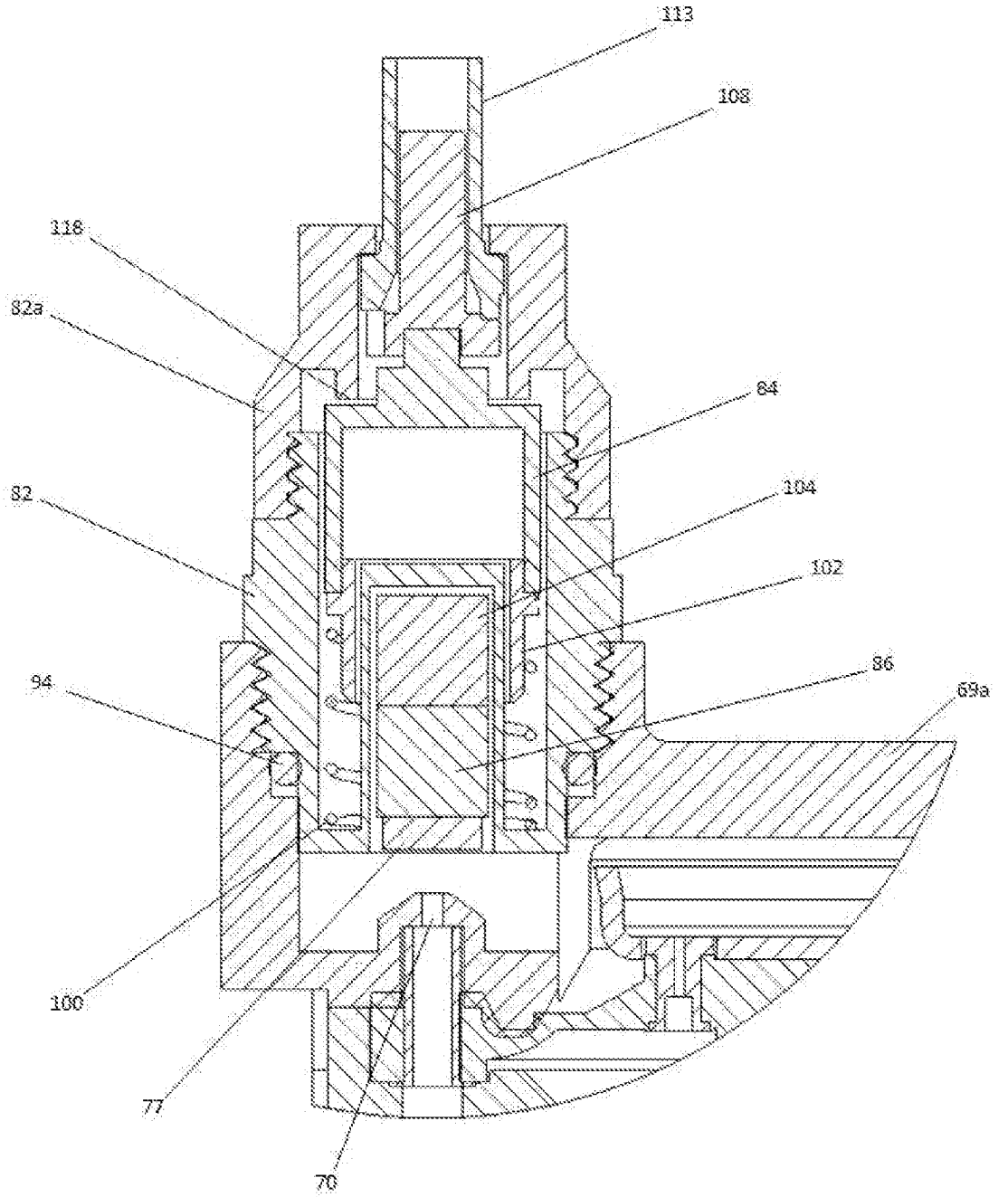

Fig. 8a

09 07 24

09 07 24

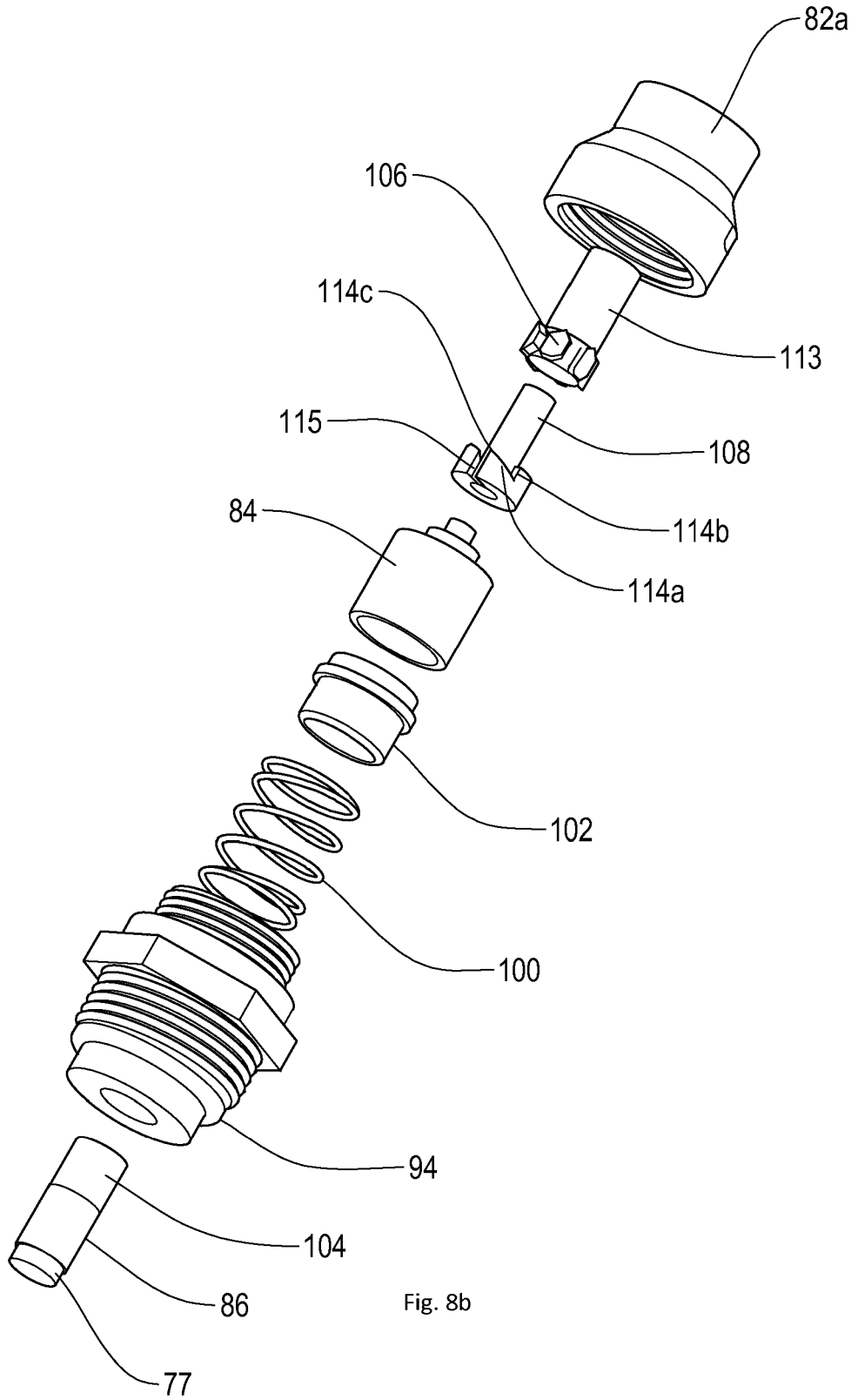

Fig. 8b

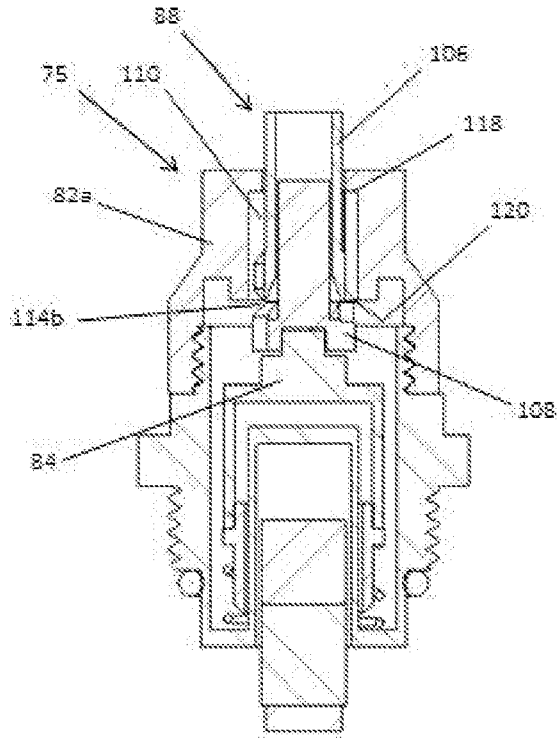

Fig. 9a

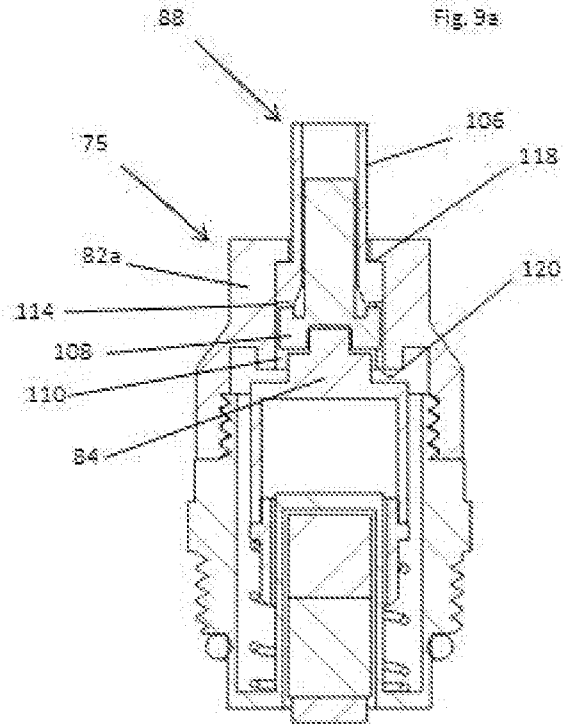

Fig. 9b

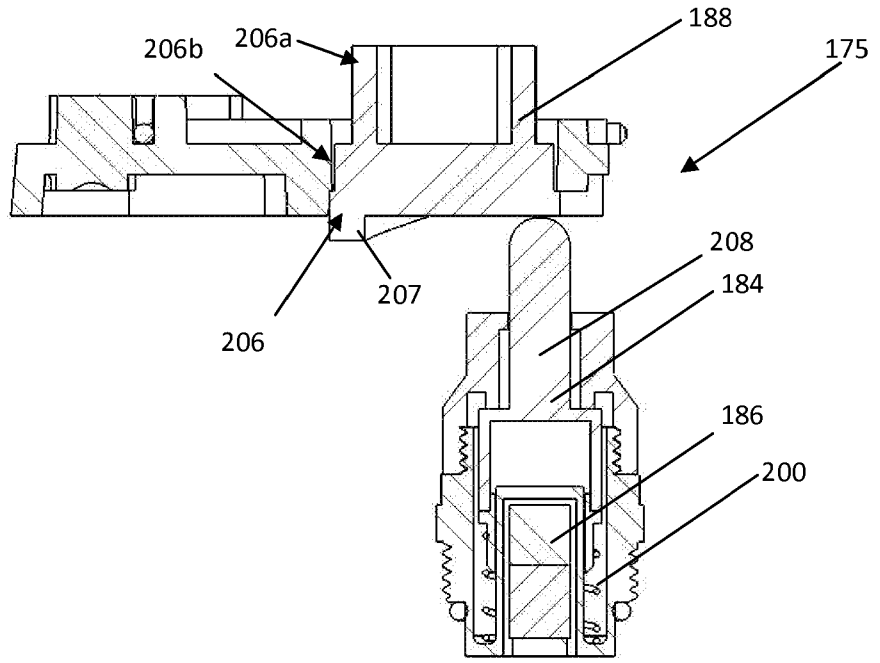

Fig. 10a

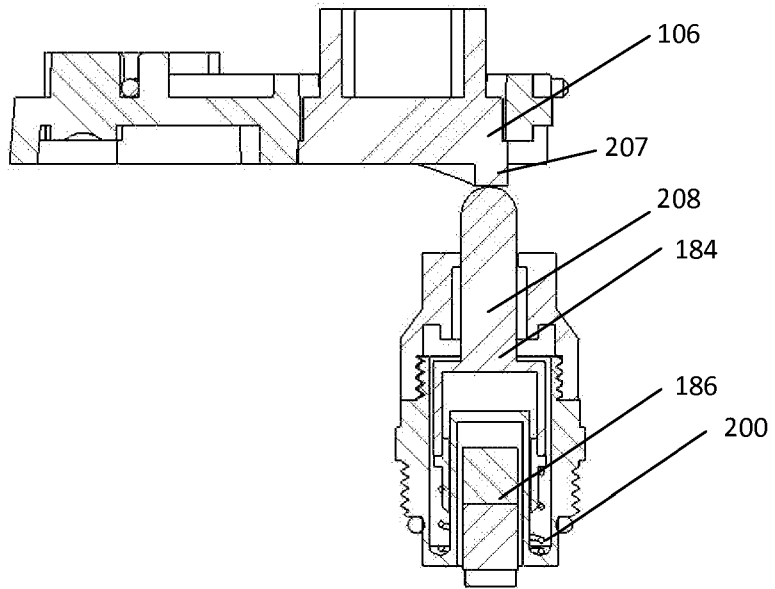

Fig. 10b

Title: A water heater

5 Description of Invention

The present invention relates to a water heater, in particular, but not exclusively, an instantaneous water heater.

10 An electric shower is an example of an apparatus which has an instantaneous water heater for heating water for use by a user during showering. The water heater has a heating chamber for receiving water from a mains water supply and one or more electrically operated heating elements positioned in the heating chamber for heating the water.

15 A number of known prior art such showers have two heating elements within the heating chamber, and have controls (usually on a front facing surface of the shower cover ) to control operation of the shower. There may be a control for turning the shower on/off and controlling operation of the heating elements so that none, one or both of the elements are operated. In certain showers, a separate control, e.g. a push button, may be provided to turn the shower  
20 on/off, and a separate control, e.g. a dial or slidable switch, may be provided to control operation of the heating elements. The ability to selectively operate the heating elements so that all, or a subset of them, may be operated is required because the temperature of ambient water will vary, and so, during a hot day, only a single heating element may be required to bring the water to the required final temperature and, during a cold day, both heating elements  
25 may be required to do so. Prior art showers may also include a control for adjusting the temperature of the water outputted by the shower. The control is configured to vary the flow rate of water through the heating chamber so as to control the amount of heat absorbed by the water before it is outputted.

30

Prior art electric showers generally include a valve assembly for controlling the flow of water from a mains inlet of the shower to the heating chamber. The valve assembly would be positioned to lie immediately downstream of the mains inlet of the shower and upstream of the  
35 rest of the water conduit components of the shower. The valve assembly will typically be operable between open (when the shower is turned on) and closed positions (when the shower is turned off) through the use of a solenoid valve that requires electrical power to be supplied for its operation.

In more detail, an example of such a prior art valve assembly 10 is shown in figures 1 and 2. The valve assembly 10 includes a valve inlet chamber 12 for communication with the mains inlet (not shown), a pilot chamber 14 for communication with the valve inlet chamber 12, and, a valve outlet chamber 16 for communication with the valve inlet chamber 12 and the chamber of the water heater (not shown). The valve assembly 10 includes a diaphragm 18 positioned in the pilot chamber 14 moveable between a first position, in which flow of water from the valve inlet chamber 12 to the valve outlet chamber 16 is inhibited, and a second position, in which flow of water from the valve inlet chamber 12 to the valve outlet chamber 16 is permitted. The valve outlet chamber 16 defines a seat on which the diaphragm 18 sits in its first position to prevent the flow of water into an inlet opening 15 of the valve outlet chamber 16. The diaphragm 18 extends across the outlet opening 15 of the valve outlet chamber 16 and an inlet opening 17 of the valve inlet chamber 12.

The diaphragm 18 includes a pilot hole 20 positioned centrally thereof for use in controlling movement of the diaphragm 18 between its first and second positions during use by permitting communication between the pilot chamber 14 and the valve outlet chamber 16. Diaphragm 18 is connected to a guide member 19 that extends into the valve outlet chamber 16 to constrain movement of the diaphragm 18 relative to the chamber 16 and provides a pilot passage in communication with pilot hole 20. The diaphragm 18 further includes a bleed inlet 21 positioned arranged radially outwardly from the pilot hole 20 and configured so as to permit water to flow from the valve inlet chamber 12 to the pilot chamber 14 irrespective of whether the diaphragm 18 is in its first or second positions.

The valve assembly 10 includes a blocking device 22 operable by a solenoid 24 thereof. The blocking device 22 includes a metal rod 26 movable within a recess of the blocking device 22 between a retracted and an extended position. The metal rod 26 includes a blocking member 28, in the form of a rubber seal, at a lower end thereof. The metal rod 26 is arranged vertically and aligned with respect to the pilot hole 20 such that, in its extended position, the blocking member 28 blocks the pilot hole 20 so as to close the pilot hole 20, and, in its retracted position, the blocking member 28 is spaced above the pilot hole 20 so to open the pilot hole 20. The metal rod 26 is biased to its extended position by a spring 27 positioned above the metal rod 26 within the recess.

Movement of the blocking device 22 is effected by solenoid 24. Solenoid 24 includes electrical connectors 30 to provide power thereto and connect it to control circuitry of the shower. During operation, electrical power must be supplied to the solenoid 24 so that, on a user turning the shower on, the solenoid 24 is operated by the control circuitry so that a coil of the

solenoid 24 generates a magnetic field. The magnetic field exerts a force on the metal rod 26 urging it upwards into its retracted position, thereby lifting the blocking member 28 and opening the pilot hole 20.

5 Operation of the valve assembly 10 will now be described. With reference to figure 2, when the shower is off, the blocking member 28 is urged, by the spring 27 acting on metal rod 26, to abut, and close the pilot hole 20. Water in the valve inlet chamber 12 is permitted to flow into the pilot chamber 14 through the bleed inlet 21. However, water cannot flow from the pilot chamber 14 into the valve outlet chamber 16 because the diaphragm 18 is in its closed  
10 position, blocking the flow of water thereto. As the pilot chamber 14 and valve inlet chamber 12 are in fluid communication, the pressure in both chambers is equal. For this reason, there is no pressure differential across the diaphragm 18 and so the diaphragm 18 stays in its closed position.

15 When the shower is turned on by a user, the solenoid 24 effects movement of the metal rod 26 so that the blocking member 28 is lifted and the pilot hole 20 opened. Water can now flow from the pilot chamber 14 into the valve outlet chamber 16 via the pilot hole 20. The pressure in the pilot chamber 14 thus decreases, causing a pressure differential to occur across the diaphragm 18 which urges the diaphragm 18 upwards into its open position, thus permitting  
20 the flow of water from the valve inlet chamber 12 into the valve outlet chamber 16.

When the shower is turned off by the user, the solenoid 24 is turned off, thereby removing its magnetic field and the metal rod 26 is urged to its extended position thus pushing the blocking member 28 to its closed position in which it closes the pilot hole 20. With the pilot hole 20 now  
25 closed, the pressure differential is removed and the diaphragm 18 thus moves back to its closed position.

There are drawbacks with such valve assembly designs. The presence of the guide member 19 providing the pilot passage within the valve outlet chamber 16 means that it lies directly in  
30 the flow and so it creates a restriction to the flow capacity; particularly so for situations where there is low mains water pressure. The arrangement of the metal rod 26 and blocking member 28 being above the diaphragm 18 restricts how far the diaphragm 18 can move in its open position and, if the diaphragm 18 lifts too far, the pilot hole 20 may engage with the blocking member 28 even though the metal rod 26 is in its retracted position. Thus a "shut-off"  
35 situation may occur and/or limitations on the movement of the diaphragm will effect water flow, particularly at low pressures.

The present invention, amongst other things, seeks to ameliorate the issues and drawbacks associated with prior art valve assemblies in this field.

According to an aspect of the present invention we provide a water heater including:

- 5 an inlet for connection to a water supply;  
a housing defining a heating chamber for receiving water;  
an electrically operable heating element positioned in the heating chamber;  
an outlet for connection to an output device, wherein the outlet is in  
communication with the heating chamber to receive water therefrom during use; and  
10 a valve assembly connected to the inlet to receive water therefrom and for permitting  
and inhibiting the flow of water downstream of the valve assembly; the valve assembly  
including:  
a valve inlet chamber in communication with the inlet;  
a pilot chamber for communication with the valve inlet chamber, wherein  
15 the pilot chamber has a main pilot chamber portion and a secondary pilot chamber  
portion;  
a valve outlet chamber for communication with the valve inlet  
chamber and the heating chamber,  
a bleed inlet for permitting water to flow from the valve inlet chamber to the  
20 pilot chamber;  
a pilot inlet in communication with the pilot chamber which may be opened to  
permit water flow from the pilot chamber, and which may be closed to inhibit water  
flow from the pilot chamber;  
a blocking device having a blocking member moveable between a first  
25 position, in which the blocking member blocks the pilot inlet so as to close the pilot  
inlet to inhibit flow of water from the pilot chamber, and, a second position in which the  
blocking member does not block the pilot inlet so as to open the pilot inlet to permit  
flow of water from the pilot chamber; and  
a diaphragm positioned in the pilot chamber which is moveable in the main  
30 pilot chamber portion between a first position, in which flow of water from the valve  
inlet chamber to the valve outlet chamber is inhibited by the diaphragm, and a second  
position, in which flow of water from the valve inlet chamber to the valve outlet  
chamber is permitted by the diaphragm,  
wherein, the pilot inlet, when opened, effects movement of the diaphragm to  
35 its first position, and, when closed, effects movement of the diaphragm to its second  
position, and  
wherein the pilot inlet is spaced away from the main pilot chamber portion.

Optionally or preferably the pilot inlet is positioned in the secondary pilot chamber portion and/or the secondary pilot chamber portion is adjacent the main pilot chamber portion.

- 5 Optionally or preferably the pilot inlet is spaced apart from the bleed inlet, preferably or optionally, laterally spaced apart.

Optionally or preferably including a bleed passage having a first end including the bleed inlet and a second end including a bleed outlet, wherein the diaphragm includes, or, is connected to, the bleed passage, and optionally or preferably the bleed inlet is positioned in the valve inlet chamber, and/or the bleed outlet is positioned in the main pilot chamber portion.

Optionally or preferably including a pilot passage having a first end in communication with the pilot inlet and a second end including a pilot outlet, and/or optionally or preferably the pilot inlet is positioned in the secondary pilot chamber portion.

Optionally or preferably the bleed passage and pilot passage extend parallel to each other.

Optionally or preferably including a valve outlet member connected to the valve outlet chamber to receive water therefrom, and optionally or preferably the pilot inlet is fluidly connected to the valve outlet member.

Optionally or preferably the valve inlet chamber surrounds at least a portion of the valve outlet chamber, optionally or preferably the valve outlet chamber and the valve inlet chamber are each generally cylindrical.

Optionally or preferably the valve outlet chamber includes an end defining an opening for communication with the valve inlet chamber, and wherein the diaphragm rests on the end to block the opening when the diaphragm is in its first position.

Optionally or preferably the valve inlet chamber includes an end defining an opening for communication with the valve outlet chamber, and wherein the diaphragm blocks the opening to inhibit said communication when the diaphragm is in its first position.

Optionally or preferably the bleed inlet is in communication with the valve inlet chamber.

Optionally or preferably including a first housing which includes the valve outlet chamber and valve inlet chamber, optionally or preferably the valve outlet chamber and valve inlet chamber are integrally formed by the housing as a single component part.

Optionally or preferably the diaphragm is biased towards its first position, optionally or preferably including a biasing device for biasing the diaphragm towards its first position.

- 5      Optionally or preferably the blocking device is mechanically operable, or electrically operable, to drive movement of the blocking member from its first position to its second position. and/or optionally or preferably the blocking device is positioned to overlie the secondary pilot chamber portion.
- 10     Optionally or preferably the blocking device includes:
- a first member and a second member including the blocking member, wherein the first and second members are magnetically coupled such that movement of the first member causes movement of the second member; and
- an actuator mechanically operable to effect movement of the first member to
- 15     move the second member between first and second positions,
- wherein, in the first position, the second member urges the blocking member to block the pilot inlet, and, in the second position, the second member holds the blocking member away from the pilot inlet so the pilot inlet is not blocked.
- 20     According to another aspect of the present invention we provide a water heater including:
- an inlet for connection to a water supply;
- a housing defining a heating chamber for receiving water;
- an electrically operable heating element positioned in the heating chamber;
- an outlet for connection to an output device, wherein the outlet is in
- 25     communication with the heating chamber to receive water therefrom during use; and
- a valve assembly connected to the inlet to receive water therefrom and for permitting and inhibiting the flow of water downstream of the valve assembly, the valve assembly including:
- a valve inlet chamber in communication with the inlet;
- 30     a pilot chamber for communication with the valve inlet chamber;
- a valve outlet chamber for communication with the valve inlet chamber and the heating chamber,
- a bleed inlet for permitting water to flow from the valve inlet chamber to the pilot chamber;
- 35     a pilot inlet in communication with the pilot chamber which may be opened to permit water flow from the pilot chamber, and which may be closed to inhibit water flow from the pilot chamber;

a diaphragm positioned in the pilot chamber moveable between a first position, in which flow of water from the valve inlet chamber to the valve outlet chamber is inhibited by the diaphragm, and a second position, in which flow of water from the valve inlet chamber to the valve outlet chamber is permitted by the diaphragm;

wherein, the pilot inlet, when opened, effects movement of the diaphragm to its first position, and, when closed, effects movement of the diaphragm to its second position, and

a blocking device including:

a first member, and a second member including a blocking member for blocking the pilot inlet, wherein the first and second members are magnetically coupled such that movement of the first member causes movement of the second member;

an actuator mechanically operable to effect movement of the first member to move the second member between first and second positions,

wherein, in the first position, the second member urges the blocking member to block the pilot inlet, and, in the second position, the second member holds the blocking member away from the pilot inlet so the pilot inlet is not blocked.

Optionally or preferably the blocking device includes a housing defining:

a) a first space in which the first member is positioned; and

b) a second space for receiving the second member,

wherein the first space is sealed with respect to the second space,

and, optionally or preferably the second space is in fluid communication with pilot chamber, preferably or optionally the second space opens into the secondary pilot chamber portion.

Optionally or preferably wherein the first member is configured to move linearly and / or the second member is configured to move linearly.

Optionally or preferably the first member is moveable between first and second positions which correspond to the first and second positions of the second member respectively, optionally or preferably including a biasing device for biasing the first member to its second position and optionally or preferably, when dependent directly or indirectly on claim 17, the biasing device is positioned in the first space.

Optionally or preferably the first member includes one of a magnet or a magnetically susceptible material, and the second member includes the other of the magnetic or magnetically susceptible material.

- 5      Optionally or preferably the actuator includes a cam member and the first member includes a cam follower, wherein the cam member engages with the cam follower to effect movement of the first member, optionally or preferably the cam member is rotationally moveable, or the cam member is linearly moveable.
- 10     Optionally or preferably:
- a) the blocking device includes first and second stop elements;
  - b) the cam member includes a series of cam formations; and
  - c) the cam follower includes a series of cam follower formations,
- 15     wherein the blocking device, cam member and cam follower are configured such that, in a first configuration, the second stop elements engage with the cam follower formations to hold the first member in an extended position, and, in a second configuration, the second stop elements do not engage the cam follower formations and the first stop element engages with the cam formations to retain the first member in a retracted position, and optionally or preferably the first configuration corresponds to the first position of the
- 20     first member and the second configuration corresponds to the second position of the first member.

Optionally or preferably operation of the actuator includes the cam member moving axially and movement of the cam member causes the cam follower to rotate, and/or optionally or preferably operation of the actuator causes the blocking device, cam member and cam follower to move from the first or second configuration to the other of the first or second configuration.

30     Optionally or preferably the water heater according to any preceding clause is an instantaneous water heater.

According to another aspect of the present invention we provide a hand wash unit or shower including a water heater according to any preceding clause.

35     Embodiments of the invention will now be described, by way of example only, with reference to the accompanying drawings, of which:

Figure 1 is a side-cross section view of a prior art solenoid valve assembly for a water heater;

Figure 2 is a partially enlarged cross-section view of the solenoid valve assembly of figure 1 showing the flow of water in a closed state thereof;

- 5 Figure 3 is a plan view of a water heater in accordance with embodiments of the present invention;

Figure 4 is a plan view showing the internal components of the water heater of figure 3;

- 10 Figure 5 is a side cross-section view of a component part of the water heater of figure 3 in a first, closed, state showing the flow of water therein;

Figure 6 is a side cross-section view of the component part of figure 5 in a second, open, state showing the flow of water therein;

15

Figure 7 is a side cross-section partial view of a component of the component part of figure 4 and 5 in a first, closed, state;

- 20 Figure 8a is a side cross-section partial view of the component of figure 7 in a second, open, state;

Figure 8b is a perspective exploded view of the components of figure 7 ;

- 25 Figures 9a and 9a are magnified views of a component of figure 7 in the first, closed, state, and second, open, state respectively; and

Figures 10a and 10b correspond to side cross-section views of a component part according to embodiments of the present invention in first and second states respectively.

- 30 With reference to figures 3 to 10, embodiments of the present invention will be described. Although these embodiments are described in relation to a shower, it will be appreciated that embodiments may similarly be employed for other types of water heater, e.g. hand washer units.

- 35 Figure 3 shows a water heater 32 including an external cover 36, control 38, in the form of a push-button, for turning the water heater on or off (which may start or stop water flow into the water heater 32), control 40, in the form of a dial, for operating heating elements of the water

heater 32, and a control 42, in the form of dial, for controlling the flow rate of water through the water heater so as to vary the temperature of water outputted by the water heater 32. Water heated by the water heater 32 leaves through an outlet 44 which is connectable to an output device (not shown), e.g. a hose connected to a shower head, for a user to direct the heater water onto the user's body as desired.

Figure 4 shows the internal components of the water heater 32. The water heater 32 includes first and second inlets 46, 48, either of which may be connected to a water supply depending on the direction of a mains water supply pipe on site. The inlet(s) 46, 48 may be directly connected to a mains water supply pipe and receive the mains water supply before the water travels downstream of the inlet(s) 46, 48 into the rest of the water heater 32. In embodiments, the water heater 32 may include a single inlet.

The water heater 32 includes a housing 50 defining a heating chamber / main chamber for receiving water and a pair of electrically operable heating elements 52, 54 positioned in the heating chamber. The outlet 44 is in communication with the heating chamber to receive water therefrom during use.

The water heater 32 includes a power selector switch 56 that is connected to the control 40 and which switch 56 is operatively connected to the heating elements 52, 54 by control circuitry.

The water heater 32 includes a valve assembly 58 connected to the inlets 46, 48 to receive water therefrom and for permitting and inhibiting, e.g. starting and stopping, the flow of water downstream of the valve assembly 58. The valve assembly 58 may thus permit or inhibit the flow of water received by the inlet 46 or 48 so as to permit or inhibit water flowing downstream from the valve assembly 58 to the other components of the water heater 32.

The water heater 32 includes a flow control valve 60 that is connected to control 42. The flow control valve 60 is downstream of the valve assembly 58 and connected thereto to receive water from the valve assembly 58, and upstream of the heating chamber and connected thereto so that the flow control valve 60 controls the flow of water into the heating chamber.

With reference to figures 5, and 6, the valve assembly 58 includes a valve inlet chamber 62 in communication with the inlets 46, 48, a pilot chamber 64 in communication with the valve inlet chamber 62, a valve outlet chamber 66 for communication with the valve inlet chamber 62 and the heating chamber, a bleed inlet 68, e.g. an opening, for permitting water to flow from the

- valve inlet chamber 62 to the pilot chamber 64, a pilot inlet 70, e.g. an opening, in communication with the pilot chamber 64 which may be opened to permit water to flow from the pilot chamber 64 (as shown in figure 6), and which may be closed to inhibit the flow of water from the pilot chamber 64 (as shown in figure 5). The pilot chamber 64 may include a
- 5 main pilot chamber portion 65a, and a secondary pilot chamber portion 65b in embodiments. The main pilot chamber portion 65a may overlie and/or extend over the valve inlet chamber 62 and valve outlet chamber 66. The secondary pilot chamber portion 65b may be adjacent to the main pilot chamber portion 65a and extend laterally away from the portion 65a.
- 10 The valve assembly 58 includes a diaphragm 72 at least partially positioned in the pilot chamber 64 moveable between a first position (shown in figure 5), in which flow of water from the valve inlet chamber 62 to the valve outlet chamber 66 is inhibited, and a second position (shown in figure 6), in which flow of water from the valve inlet chamber 62 to the valve outlet chamber 66 is permitted. In embodiments for which the main pilot chamber portion 65a and
- 15 secondary pilot chamber portion 65b are provided, the diaphragm 72 may move within the main pilot chamber portion 65a. The pilot inlet 70, when opened, effects movement of the diaphragm 72 to its second position, and, when closed, effects movement of the diaphragm 72 to its first position. The diaphragm 72 may be made from a resiliently flexible material, e.g. rubber or the like. In embodiments, movement of the diaphragm 72 between first and second
- 20 positions refers to the diaphragm 72, or a portion thereof, deforming from a non-extended or non-deformed state (shown in figure 5) in which it is generally horizontal, to its extended or deformed state (shown in figure 6) in which the diaphragm 72 is generally lifted upwardly towards the pilot chamber 64.
- 25 In embodiments including the main pilot chamber portion 65a and secondary pilot chamber portion 65b, the pilot inlet 70 may be spaced away from the main pilot chamber portion 65a, e.g. positioned remotely, and/or provided separately from the main pilot chamber portion 65a, whilst being in communication with the main pilot chamber portion 65a. In embodiments, the pilot inlet 70 may be an opening provided by a portion of the housing which defines the second
- 30 pilot chamber portion 65b. In embodiments, the pilot inlet 70 is provided as part of the diaphragm, e.g. as a component part connected thereto or as an opening in the diaphragm. In embodiments, a blocking device 75 may be provided as a part of the valve assembly 58 itself. The blocking device 75 may include a blocking member 77 moveable between a first position (shown in figure 5), in which the blocking member 77 blocks the pilot inlet 70 so as to close the
- 35 pilot inlet 70, and, a second position (shown figure 6) in which the blocking member 77 does not block the pilot inlet 70 so as to open the pilot inlet 70. The blocking member 77 may be in the form of a rubber seal or the like.

In more detail, in embodiments, the valve inlet and outlet chambers 62, 66 are arranged such that they are generally coaxial and/or the inlet chamber 62 surrounds the outlet chamber 66 or a portion thereof. The chambers 62, 66 may each be generally cylindrical. The valve inlet chamber 62 may have a greater diameter than the valve outlet chamber 66. The chambers 62, 66 may be open at respective ends 62a, 66a which face towards the pilot chamber 64. In embodiments including main pilot chamber portion 65b, the chambers 62, 66 face towards this portion 65b. The valve outlet chamber 66 end may include a seat 67 for the diaphragm 72. The diaphragm 72 may rest on the seat 67 to block the opening defined by end 66a when the diaphragm 72 is in its first position.

The diaphragm 72 may, in embodiments, extend across the whole of the ends 62a, 66a, so as to provide a barrier between the ends 62a, 66a and the pilot chamber 64. The diaphragm 72 may include the bleed inlet 68 and have it provided on a portion of the outer, upstream surface (as considered when the diaphragm 72 is in its first position), of the diaphragm 72 facing the valve inlet chamber 62 so that the bleed inlet 68 is positioned in the valve inlet chamber 62 when the diaphragm 72 is in its first position. The diaphragm 72 may include a bleed passage 73 having a first end 73a including the bleed inlet 68, and a second end 73b including a bleed outlet 74, e.g. an opening. The bleed outlet 74 may be provided on a portion of the outer, downstream surface (as considered when the diaphragm is in its first position) of the diaphragm 72 facing the pilot chamber 64 so that the bleed outlet 74 is positioned in the pilot chamber 64. In embodiments, the bleed inlet 68, bleed passage 73 and bleed outlet 74 may be provided as a single component part, e.g. a metal pressing or the like, that is connected to the diaphragm 72 and extends therethrough.

The diaphragm 72 may be connected to a guide 76 for guiding movement of the diaphragm 72. The guide 76 includes a first end 76a, a second end 76b and a connecting section 76c extending therebetween. The first end 76a abuts a portion of the outer, downstream, surface of the diaphragm 72 which faces into the valve outlet chamber 66, and the second end 76b abuts a portion of the outer, upstream, surface of the diaphragm which faces into the pilot chamber 64. The first end 76a may be in the form of a generally flat disc shape, e.g. made from metal. The second end 76b may be generally circular, and may have an upturned flange around its circumference. The connecting section 76c defines a passage 76d therein which opens up into the pilot chamber 64. The connecting section 76c may be formed integrally with the first end 76 a as a single component piece made from, for example, metal.

In embodiments, the diaphragm 72 includes a main portion 72a, which may be generally circular in embodiments, and a secondary portion 72b which extends away from a periphery of the main portion 72a. The main portion 72a may be positioned in the main pilot chamber portion 65a and/or the secondary portion 72b may be positioned in the secondary pilot chamber portion 65b. The main portion 72a may be configured so as to move within the main pilot chamber portion 65b and may include the guide 76 connected thereto. The secondary portion 72b may include a recess indirectly connected to the pilot inlet 70 as will be described. The secondary portion 72b may extend so as to lie below the secondary pilot chamber portion 65b.

The pilot chamber 64 and/or main pilot chamber portion 65a thereof where provided in embodiments, may be configured to overlie the valve inlet and outlet chambers 62, 66. The pilot chamber 64 and/or the main pilot chamber portion 65b thereof may be a generally disc shaped space.

The chambers 62, 64, 66, may be internal spaces defined by respective portions of a housing 69 of the valve assembly 58. The housing 69 may be made from metal or any suitable material. A portion 69a of the housing 69 may define at least a part of the secondary pilot chamber where provided and/or provide the pilot inlet 70 therein. Portion 69a may be near, or at, a respective end portion of the housing 69 that is spaced apart from the valve inlet and outlet chambers 62, 64. In embodiments, portion 69a may include a section that abuts the secondary portion 72b of the diaphragm 72 so as to hold this portion 72b in place.

The valve assembly 58 may include a pilot passage 59 having a first end 59a, in communication with the pilot inlet 70, and may include a second end 59b including a pilot outlet 71, e.g. an opening. In embodiments, the pilot passage 59 may be provided by the housing 69. In embodiments, the pilot passage 59 may include a tubular member 59c which extends from the first end 59a / pilot inlet 70 and may also extend through the diaphragm 72, e.g. secondary portion 72b thereof. The pilot passage 59 may extend axially and be laterally spaced apart from the valve chambers 62, 66. The pilot passage 59 may extend parallel to the chambers 62, 66. The bleed passage 73 and pilot passage 59 may extend parallel to each other in embodiments.

In embodiments, housing 69 may include a first housing 69b which includes the valve outlet chamber 66 and valve inlet chamber 62, and may be integrally formed by the housing 69b as a single component part. The housing 69 may include a second housing 69c which is connected, e.g. fastened thereto, to the first housing 69b so as to define the pilot chamber 64.

In embodiments, at least a portion of the pilot passage 59 may be provided by the housing 69, and/or be provided by the first housing 69b. For embodiments having a first and second housing 69b, 69c, the diaphragm 72 is pressed at its circumference between the mating surfaces of the housings 69b, 69c within a complimentary recess defined therein.

5

The valve assembly 58 may include a valve outlet member 78 connected to the valve outlet chamber 66 to receive water therefrom, and/or a valve inlet member 80 connected to the valve inlet chamber 62 to provide water thereto. These members 78, 80 may be formed as part of the housing 69 or may be provided by other component parts of the water heater 32 and connect to the respective chambers 62, 66 differently. In embodiments including the valve outlet member 78, the pilot passage 59 is positioned so that its second end 59b and the pilot outlet 71 are connected to the valve outlet member 78. In embodiments including a secondary pilot chamber portion 65b, the pilot passage 59 may extend downwardly away from the secondary pilot chamber portion 65b. In embodiments, the valve assembly 58 may not have member 78, and/or member 80. The relevant inlet / outlet conduits may connect directly to the chambers 62, 66 instead. In said arrangements, the pilot passage 59 and pilot outlet hole 71 may be connected to the said outlet conduit.

10

15

The valve assembly 58 may be configured so that the diaphragm 72 is biased towards its first position. In embodiments, this may be achieved through a biasing device 81. In embodiments, the biasing device 81 may be a spring which has a first end connected to the diaphragm 72 (at the main portion 72a where provided) or a part connected thereto, e.g. the guide 76, and a second end connected to a portion of the housing 69 which faces towards the diaphragm 72, thereby urging the diaphragm 72 in a downwards direction towards the valve seat 67.

20

25

With reference to figures 7, 8 and 9, the blocking device 75 will now be described in more detail.

30

The blocking device 75 includes a first member 84, and a second member 86 including the blocking member 77 for blocking the pilot inlet 70. The blocking device 75 includes an actuator 88 mechanically operable to effect movement of the first member 84 to move the second member 86 between first and second positions. The actuator 88 may be coupled directly or indirectly to control 38 so that, when the control 38 is pressed by a user, the actuator 88 moves to cause the first member 84 to move without any electrical power being required. In the first position (see figure 7), the second member 86, is urged to hold the blocking member 77 so as to block the pilot inlet 70, and, in the second position (see figure

35

8a), the second member 86 does not block the pilot inlet 70. As will be described, the first and second members 84, 86 are magnetically coupled such that movement of the first member 84 causes movement of the second member 86 without any electrical power being required. Mechanical movement of the actuator 88 thus effects operation of the blocking device 75 without the requirement of any electrical power. The first member 84 is moveable between first and second positions that correspond to the first and second positions of the second member 86 respectively.

In embodiments, the blocking device 75 may include a housing 82 which may be connected, e.g. removably connected, to the remainder of the valve assembly 58. The housing 82 may be generally elongate and/or may extend generally vertically in side view. The housing 82 may be connected, to a portion, e.g. portion 69a, which defines at least a portion of the pilot chamber 64, e.g. the secondary pilot chamber portion 65b where provided. The connection may be a threaded connection to permit easy removal of the blocking device 75 for replacement and/or repair thereof.

The housing 82 defines a first space 90, internally of the housing 82, in which the first member 84 is positioned; and a second space 92, external of the housing 82, for receiving the second member 86. The first space 90 is sealed with respect to the second space 92. This may provide the advantage of preventing leakages from the space 92 to other areas of the water heater where electrical components may be present. Also, by not having to prevent an additional sealing mechanism, high pressures are not generated that could otherwise affect operation of the valve assembly. The second space 92 is in communication with the pilot chamber 64. In embodiments, where provided, the second space 92 opens into the secondary pilot chamber portion 65b.

The housing 82 may have a first, upper, end 82a, which sits adjacent the cover 36, and a second, lower, end 82b which is connected to the housing 69. The second end 82a may include a thread which mates with a complementary thread provided on an inwardly facing side wall of the housing 82. An o-ring 94 may be positioned between the second end 82b and an end face of the housing 69 to seal therebetween.

The housing 82 may be generally cylindrical. The housing 82 may include an externally facing recess 96 (facing towards pilot chamber 64) that extends inwardly from, and centrally of, the second end 82b to define the second space 92 to the outside of the housing 82. The first space 90 is generally n-shaped in side cross-section and its lower portion surrounds the second space 92.

The first member 84 may have a first, upper, end 84a which is positioned adjacent to the actuator 88 and a second, lower, end, 84b which extends towards the second end of the housing 82.

5

The first member 84 may be generally tubular and may be open at its lower end 84b. The first member 84 may include an intermediate member 98 that may also be generally tubular and/or have a radially extending flange 98a upon which the other part of the first member 84 sits. The second, lower, end 82b of the housing 82 partially extends into the lower end of the intermediate member 98. The intermediate member 98 may include a portion 102 formed from a magnetically susceptible material, e.g. metal, or a magnetic material at its lower end. The portion 102 may extend around or surround the second space 92. In embodiments, there the first member 84 may be fixedly connected, integrally formed, or otherwise configured, e.g. a single component piece of metal, to include one or more of the features of the intermediate member 98. In embodiments, the first member 84 may have no separate intermediate member 98, and instead, the first member 84 may be a single component part which extends all the way down to rest on the bottom wall on the inside of the housing 82. In embodiments, the first and second members 84, 86, and/or housing 82 may have alternative shapes or configurations. The members 84, 86, and/or housing 82 may have complementary shapes that can be accommodated within the spaces 90, 92 defined by the housing 82.

10

15

20

A biasing device 100 biases the first member 84 to its second position. The biasing device 100 may be a spring and/or it may be provided in the first space 90. The biasing device 100 may surround the intermediate member 98 and sit between the flange 98a and the bottom wall of end 82b of the housing 82 so as to bias the first member 84 away from the lower end 82b of the housing 82. In embodiments not having a separate intermediate member 98, the first member 84 may incorporate a flange which rests on the biasing device 100. The first member 84 may move linearly between its first and second positions within the first space 90.

25

30

35

The second member 86 may be generally elongate and rod-shaped to complement the shape of the second space 92 in which it is received. The second member 86 may support a magnet 104 at a first, upper, end 86a thereof, and the blocking member 77 at a second, lower, end 86b thereof. The second member 86 is not mechanically connected to the housing 82 and is held in place due to the magnetic coupling between the second member 86 and the intermediate member 98 which surrounds / extends around it. In embodiments for which the first member 84 has no separate intermediate member 98, the magnetic coupling is between the first and second members 84, 86. As will be described, the second member 86 is

configured to move linearly between its first, extended, position (figure 7) and its second, retracted, position (figure 8a).

5 The actuator 88 may be coupled to the upper end of the first member 84. The actuator 88 may include a cam member 106 for engaging with a cam follower 108 coupled to the first member 84. The cam member 106 engages with the cam follower 108 to effect movement of the first member 84. The actuator 88 is positioned within a recess 110 provided at the upper end of the housing 82a. The actuator 88 extends upwardly outside of the housing 82a through the recess 110.

10

The cam member 106 may include a series of cam formations 112 and the cam follower 108 may include a series of cam follower formations 114 separated by axially extending grooves 115 between the formations 114. The actuator may include a tubular shaft 113 having a lower end including cam member 106 and the cam formations 112. The cam formations 112 are a series of ribs that are uniformly spaced apart from one another. The cam follower 108 includes a tubular shaft 116 that extends through the tubular shaft 113 and has a lower end on which the cam follower formations 114 are provided. The cam follower formations 114 (see figure 8b) are a series of inclined surfaces, forming saw tooth-like edges, each formation beginning at a first, bottom, point 114a, terminating at a second, top, point 114b with a smooth inclined surface 114c extending therebetween. A respective groove 115 separates respective adjacent cam follower formations 114. The tubular shaft 116 rests on the top of the first member 84. In more detail, the first member 84 includes an upwardly extending central projection that extends into the tubular shaft of the cam follower 108.

15

20

25 The blocking device 75 includes first and second stop elements 118, 120 for interaction with the first member 84 and cam member 106 / follower 108 as will be described.

In embodiments, the first stop element 118 is provided by a downwardly facing surface at the first, upper, end 82a of the housing 82. The surface may be defined by a downwardly extending circular flange. The second stop elements 120 are a series of radially inwardly extending elongate ribs that are spaced apart along the housing 82 about the recess 110 thereof.

30

The blocking device 75, actuator 88, cam member 106 and cam follower 108 are configured in a first configuration such that, in the first position of the first member 84, the second stop elements 120 engage with the cam follower formations 114b to hold the first member 84 in an extended, lowered, position (see figure 9a), and a second configuration such that, in the

35

second position of the first member, the second stop elements 120 do not engage the cam follower formations 114 and the first stop element 118 engages with the cam member 106 to retain the first member 84 in a retracted, raised, position (see figure 9b ). Movement of the actuator 88 includes the cam member 106 moving axially and movement of the cam member 108 causes the cam follower 108 to rotate. As will be described, movement of the actuator 88 causes the actuator 88 to move from its first or second configuration to the other of its first or second configuration. The actuator 88 is functionally akin to the retractable mechanism utilised in ballpoint and mechanical pencils.

10 Operation of the valve assembly 58 as part of the water heater 32 will now be described. Starting from a state in which the water heater 32 is off, the blocking device 75 will be in the configuration shown in figure 7 with the first and second members 84, 86 in their respective first positions such that the blocking member 77 blocks the pilot inlet 70 so as to close it. The actuator 88, in this position, is arranged so that the second stop elements 120 engage at  
15 respective lower ends thereof with corresponding cam follower formations 114 at the respective second, top, points 114b thereof. This effectively causes the first member 84 to be urged, against the force of the biasing device 100, towards the lower end 82b of the blocking device 75 to be positioned there. Due to the first member 84 being magnetically coupled to the second member 86, the first member 84, through intermediate member 98, exerts a  
20 magnetic force on the second member 86 so as to keep the second member 86 in its second, extended, position. In this position, the second member 86 pushes against the pilot hole 70, with the blocking member 77 closing the pilot hole 70.

In the "off" state of the water heater, water from the first or second inlet 46, 48, depending on  
25 which inlet is connected to the mains water supply, fills the valve inlet member 80 and the valve inlet chamber 62. Water similarly fills the pilot chamber 64 through the bleed inlet 68 being in communication with the pilot chamber 64. The water in the valve inlet chamber 62 and pilot chamber 64 is thus at the same pressure, meaning that there is no pressure differential across the diaphragm 72. The biasing device 81 thus urges the diaphragm 72 to  
30 its first position in which the flow of water from the valve inlet chamber 62 to the valve outlet chamber 66 is blocked due to the diaphragm 72 blocking the openings of the chambers 62a, 66a.

To turn the water heater to its "on" state, the user presses control 38. Control 38 is connected  
35 to the actuator 88 and so movement of the control 38 causes the cam member 106 to push down on the cam follower 108 until the cam follower formations 114 disengage from the second stop elements 120. Due to the biasing device 100 pushing upwards on the first

member 84, and the shape of the cam follower formations 114, the cam follower 108 is caused to rotate so as to cause the cam member 106 formations to come into engagement with the respective first, bottom, points 114a of the cam follower formations 114 whilst the grooves 115 slidingly receive the second stop elements 120 therein, as the first member 84 moves upwardly until the first stop element 118 engages with the first member 84 to prevent further movement of the first member 84. The first member 84 is now in its second, retracted, position.

The movement of the first member 84 to its second position, effects movement of the second member 86 to its second position because there is a magnetic coupling between the first and second members 84, 86. When the first member 84 moves, a corresponding movement of the second member 86 occurs. Thus the second member 86 is moved to its retracted state so that it is substantially wholly positioned within the second space 92. In this position, the blocking member 77 is spaced apart, in a raised state, with respect to the pilot hole 70, leaving the pilot hole 70 open.

Water will now flow from the pilot chamber 64 towards the pilot inlet 70, and flow into the valve outlet member 78 through the pilot passage 59. Thus, a pressure drop will occur in the pilot chamber 64 which creates a pressure differential across the diaphragm 72. The diaphragm 72 is then urged to its second position, against the force of the biasing device 81, so that the valve outlet chamber 66 is in communication with the valve inlet chamber 62 and water flows from the valve inlet chamber 62 into the valve outlet chamber 66 before it exits via the valve outlet member 78 downstream to the rest of the water heater components.

When a user has finished showering, the user may operate the control 36 to turn the water heater off. Movement of the control 36 causes the blocking device 75 to be actuated. The actuator 88 is pushed downwards, causing cam member 106 to move downwardly causing a rotation of the cam follower 108 until the first stop elements 118 engage with the respective second, top, points 114b of the cam follower formations 112 thus returning the blocking device 75 to the state shown in figure 7. In doing so, the first member 84 is pushed into its first, extended, position, and, due to the magnetic coupling between the first and second members 84, 86, the second member 86 is similarly moved to its first, extended, position. In this position, the blocking member 75 is urged against the pilot inlet 70 and thereby closes the pilot inlet 70. The water pressure will now begin to equalise across the pilot chamber 64 and the valve inlet chamber 62 due to the bleed inlet 68 communicating between the two spaces, until there is no longer a pressure differential across the diaphragm 72. The biasing device 81 thus

urges the diaphragm 72 to its first position, thus stopping the flow of water to the valve outlet chamber 66.

5 The present invention, in embodiments, has a number of advantages. Due to the pilot hole 70 being located away from a main portion of the pilot chamber in which the diaphragm 72 moves during use, there is no requirement to provide a guide member with a pilot passage that extends into the valve outlet chamber 66. Thus, unlike prior art designs, there is no such guide in the flow path of the water during operation and means that the valve assembly 58 may operate better in situations where there is low water pressure. Similarly, by not having 10 the blocking device 75 being above the diaphragm 72, no restriction is placed on how far the diaphragm 72 can move in its open position. It will be appreciated that embodiments of the invention may utilise a blocking device 75 whilst still benefitting from one or more of these advantages.

15 It will be appreciated that, in embodiments, the diaphragm 72 may not include a secondary portion 72b. In such embodiments, the diaphragm 72 has a main portion 72a that is positioned in the main pilot chamber portion 65a. The pilot inlet 70 and associated pilot passage may be entirely separate from the diaphragm 72 with no direct or indirect connection therebetween.

20 Advantages are associated with the embodiments described which utilise the magnetic coupling in that no electricity needs to be supplied to operate the valve assembly 58. Thus, one may test operation of the water heater 32 to check that there are no water leaks without having to connect the water heater 32 to an electricity supply. This improves the safety of the 25 water heater 32 during installation, for example. Another advantage is that wear and tear that would occur with prior art designs is avoided through the use of a magnetic coupling.

In embodiments other types of actuator configurations may be utilised. With reference to figures 10a, 10b, these show a blocking device 175 which shares many features in common 30 with the blocking device 75 described above for use with water heaters that may have a rotary dial as a control 138 rather than a push button. Common features are denoted by the same reference numeral with the addition of 100.

35 The main difference is that the actuator 188 includes a cam member 206 which moves rotationally to effect movement of the first and second members 184, 186. In more detail, the actuator 188 / cam member 206 are supported to be rotatable about its axis. The actuator 188 has a first, upper, end 206a that sits adjacent the cover 36 and is operatively connected to the

rotatory dial control 138. The cam member 206 has a second, lower, end 206b, which includes a profiled projection 207 which extends a portion of the circumference of second end 206b and a non-raised portion which extends around the remaining portion of the circumference thereof. The first member 184 incorporates a cam follower 208 that is integrally  
5 formed as a generally elongate raised projection. The cam member 206 is positioned directly above the first member 184.

During operation, when the water heater is in its "off" state, the cam member 206 is so positioned that its profiled projection is engaged with the top of the cam follower 208 so as to  
10 urge the cam follower 208 downwards causing the first member 184 to be in its extended first position and thus the second member 186 in its extended first position. When the user rotates the control 138 to turn the water heater on and start water flow downstream into the water heater 32, the cam member 206 is rotated by the control 138 such that the profiled projection 207 moves out of contact with the cam follower 208. The cam follower 208 then  
15 moves upwards, under the force exerted by the biasing device 200, until it abuts the second stop element 220. In this condition, the first member 184 is in its second, retracted, position and so is the second member 186, thus permitted water to flow through the valve assembly 58 and to the rest of the water heater.

It will be appreciated that, in embodiments, that the magnetic coupling between the first and second members may be achieved in different ways. The first member may include one of a magnet or a magnetically susceptible material, and the second member may include the other of the magnetic or magnetically susceptible material. It will be appreciated that the described  
20 embodiments of the blocking device may be advantageously used as part of prior art valve assemblies such as those of figures 1 and 2 because no electricity is required to operate the blocking device. Other advantages of the blocking device are that space is saved overall because no spring, e.g. spring 27, is required in the as required by prior art designs to bias the metal rod 26 to a closed position. This is also desirable because spring 27 is positioned within a space that communicates with the pilot chamber / water flow path meaning that it could  
25 contaminate the water and/or corrode over time.  
30

Further aspects of the present disclosure are set out in the set of numbered clauses below.

1. A water heater including:  
35 an inlet for connection to a water supply;  
a housing defining a heating chamber for receiving water;  
an electrically operable heating element positioned in the heating chamber;

an outlet for connection to an output device, wherein the outlet is in communication with the heating chamber to receive water therefrom during use; and

a valve assembly connected to the inlet to receive water therefrom and for permitting and inhibiting the flow of water downstream of the valve assembly; the valve assembly including:

5

a valve inlet chamber in communication with the inlet;

a pilot chamber for communication with the valve inlet chamber, wherein the pilot chamber has a main pilot chamber portion and a secondary pilot chamber portion;

10

a valve outlet chamber for communication with the valve inlet chamber and the heating chamber,

a bleed inlet for permitting water to flow from the valve inlet chamber to the pilot chamber;

15

a pilot inlet in communication with the pilot chamber which may be opened to permit water flow from the pilot chamber, and which may be closed to inhibit water flow from the pilot chamber;

20

a blocking device having a blocking member moveable between a first position, in which the blocking member blocks the pilot inlet so as to close the pilot inlet to inhibit flow of water from the pilot chamber, and, a second position in which the blocking member does not block the pilot inlet so as to open the pilot inlet to permit flow of water from the pilot chamber; and

25

a diaphragm positioned in the pilot chamber which is moveable in the main pilot chamber portion between a first position, in which flow of water from the valve inlet chamber to the valve outlet chamber is inhibited by the diaphragm, and a second position, in which flow of water from the valve inlet chamber to the valve outlet chamber is permitted by the diaphragm,

wherein, the pilot inlet, when opened, effects movement of the diaphragm to its first position, and, when closed, effects movement of the diaphragm to its second position, and

30

wherein the pilot inlet is spaced away from the main pilot chamber portion.

2. A water heater according to clause 1 wherein the pilot inlet is positioned in the secondary pilot chamber portion and/or the secondary pilot chamber portion is adjacent the main pilot chamber portion.

35

3. A water heater according to clause 1 or 2 wherein the pilot inlet is spaced apart from the bleed inlet, preferably or optionally, laterally spaced apart.

4. A water heater according to clause 1, 2 or 3 including a bleed passage having a first end including the bleed inlet and a second end including a bleed outlet, wherein the diaphragm includes, or, is connected to, the bleed passage, and optionally or preferably the bleed inlet is positioned in the valve inlet chamber, and/or the bleed outlet is positioned in the main pilot chamber portion.
5. A water heater according to any preceding clause including a pilot passage having a first end in communication with the pilot inlet and a second end including a pilot outlet, and/or optionally or preferably the pilot inlet is positioned in the secondary pilot chamber portion.
6. A water heater according to clause 5, when directly or indirectly depending on clause 3, wherein the bleed passage and pilot passage extend parallel to each other.
7. A water heater according to any preceding clause including a valve outlet member connected to the valve outlet chamber to receive water therefrom, and optionally or preferably the pilot inlet is fluidly connected to the valve outlet member.
8. A water heater according to any preceding clause wherein the valve inlet chamber surrounds at least a portion of the valve outlet chamber, optionally or preferably the valve outlet chamber and the valve inlet chamber are each generally cylindrical.
9. A water heater according to any preceding clause wherein the valve outlet chamber includes an end defining an opening for communication with the valve inlet chamber, and wherein the diaphragm rests on the end to block the opening when the diaphragm is in its first position.
10. A water heater according to any preceding clause wherein the valve inlet chamber includes an end defining an opening for communication with the valve outlet chamber, and wherein the diaphragm blocks the opening to inhibit said communication when the diaphragm is in its first position.
11. A water heater according to any preceding clause wherein the bleed inlet is in communication with the valve inlet chamber.
12. A water heater according to any preceding clause including a first housing which includes the valve outlet chamber and valve inlet chamber, optionally or preferably the valve outlet chamber and valve inlet chamber are integrally formed by the housing as a single component part.

13. A water heater according to any preceding clause wherein the diaphragm is biased towards its first position, optionally or preferably including a biasing device for biasing the diaphragm towards its first position.
- 5
14. A water heater according to any preceding clause, wherein the blocking device is mechanically operable, or electrically operable, to drive movement of the blocking member from its first position to its second position. and/or optionally or preferably the blocking device is positioned to overlie the secondary pilot chamber portion.
- 10
15. A water heater according to any preceding clause wherein the blocking device includes:
- a first member and a second member including the blocking member, wherein the first and second members are magnetically coupled such that movement of the first member causes movement of the second member; and
  - 15 an actuator mechanically operable to effect movement of the first member to move the second member between first and second positions,
  - wherein, in the first position, the second member urges the blocking member to block the pilot inlet, and, in the second position, the second member holds the blocking member away from the pilot inlet so the pilot inlet is not blocked.
- 20
16. A water heater including:
- an inlet for connection to a water supply;
  - a housing defining a heating chamber for receiving water;
  - an electrically operable heating element positioned in the heating chamber;
  - 25 an outlet for connection to an output device, wherein the outlet is in communication with the heating chamber to receive water therefrom during use; and
  - a valve assembly connected to the inlet to receive water therefrom and for permitting and inhibiting the flow of water downstream of the valve assembly, the valve assembly including:
- 30
- a valve inlet chamber in communication with the inlet;
  - a pilot chamber for communication with the valve inlet chamber;
  - a valve outlet chamber for communication with the valve inlet chamber and the heating chamber,
  - a bleed inlet for permitting water to flow from the valve inlet chamber to the
- 35
- pilot chamber;
  - a pilot inlet in communication with the pilot chamber which may be opened to permit water flow from the pilot chamber, and which may be closed to inhibit water flow from the pilot chamber;

a diaphragm positioned in the pilot chamber moveable between a first position, in which flow of water from the valve inlet chamber to the valve outlet chamber is inhibited by the diaphragm, and a second position, in which flow of water from the valve inlet chamber to the valve outlet chamber is permitted by the diaphragm;

wherein, the pilot inlet, when opened, effects movement of the diaphragm to its first position, and, when closed, effects movement of the diaphragm to its second position, and

a blocking device including:

a first member, and a second member including a blocking member for blocking the pilot inlet, wherein the first and second members are magnetically coupled such that movement of the first member causes movement of the second member;

an actuator mechanically operable to effect movement of the first member to move the second member between first and second positions,

wherein, in the first position, the second member urges the blocking member to block the pilot inlet, and, in the second position, the second member holds the blocking member away from the pilot inlet so the pilot inlet is not blocked.

17. A water heater according to clause 15 or 16, wherein the blocking device includes a housing defining:

c) a first space in which the first member is positioned; and

d) a second space for receiving the second member,

wherein the first space is sealed with respect to the second space, and, optionally or preferably the second space is in fluid communication with the pilot chamber, preferably or optionally the second space opens into the pilot chamber.

18. A water heater according to clause 17 wherein the first member is configured to move linearly and / or the second member is configured to move linearly.

19. A water heater according to any one of clauses 15 to 18, wherein the first member is moveable between first and second positions which correspond to the first and second positions of the second member respectively, optionally or preferably including a biasing device for biasing the first member to its second position and optionally or preferably, when dependent directly or indirectly on clause 17, the biasing device is positioned in the first space.

20. A water heater according to any one of clauses 15 to 19 wherein the first member includes one of a magnet or a magnetically susceptible material, and the second member includes the other of the magnet or magnetically susceptible material.
- 5
21. A water heater according to any one of clauses 15 to 20 wherein the actuator includes a cam member and the first member includes a cam follower, wherein the cam member engages with the cam follower to effect movement of the first member, optionally or preferably the cam member is rotationally moveable, or the cam member is linearly
- 10
22. A water heater according to clause 21 wherein:
- d) the blocking device includes first and second stop elements;
  - e) the cam member includes a series of cam formations; and
  - 15 f) the cam follower includes a series of cam follower formations,
- wherein the blocking device, cam member and cam follower are configured such that, in a first configuration, the second stop elements engage with the cam follower formations to hold the first member in an extended position, and, in a second configuration, the second stop elements do not engage the cam follower formations and the first stop
- 20
- element engages with the cam formations to retain the first member in a retracted position, and optionally or preferably the first configuration corresponds to the first position of the first member and the second configuration corresponds to the second position of the first member.
- 25
23. A water heater according to clause 21 or 22 wherein operation of the actuator includes the cam member moving axially and movement of the cam member causes the cam follower to rotate, and/or optionally or preferably operation of the actuator causes the blocking device, cam member and cam follower to move from the first or second
- 30
- configuration to the other of the first or second configuration.
24. A water heater according to any preceding clause, wherein the water heater is an instantaneous water heater.
- 35
25. A hand wash unit or shower including a water heater according to any preceding clause.

When used in this specification and claims, the terms "comprises" and "comprising" and variations thereof mean that the specified features, steps or integers are included. The terms  
5 are not to be interpreted to exclude the presence of other features, steps or components.

The features disclosed in the foregoing description, or the following claims, or the accompanying drawings, expressed in their specific forms or in terms of a means for performing the disclosed function, or a method or process for attaining the disclosed result, as  
10 appropriate, may, separately, or in any combination of such features, be utilised for realising the invention in diverse forms thereof.

Although certain example embodiments of the invention have been described, the scope of the appended claims is not intended to be limited solely to these embodiments. The claims  
15 are to be construed literally, purposively, and/or to encompass equivalents.

Claims

1. A water heater including:  
an inlet for connection to a water supply;  
5 a housing defining a heating chamber for receiving water;  
an electrically operable heating element positioned in the heating chamber;  
an outlet for connection to an output device, wherein the outlet is in  
communication with the heating chamber to receive water therefrom during use; and  
10 a valve assembly connected to the inlet to receive water therefrom and for permitting  
and inhibiting the flow of water downstream of the valve assembly and into the heating  
chamber, the valve assembly including:  
a valve inlet chamber in communication with the inlet;  
a pilot chamber for communication with the valve inlet chamber;  
15 a valve outlet chamber for communication with the valve inlet  
chamber and the heating chamber,  
a bleed inlet for permitting water to flow from the valve inlet chamber to the  
pilot chamber;  
a pilot inlet in communication with the pilot chamber which may be opened to  
20 permit water flow from the pilot chamber, and which may be closed to inhibit water  
flow from the pilot chamber;  
a diaphragm positioned in the pilot chamber moveable between a first  
position, in which flow of water from the valve inlet chamber to the valve outlet  
chamber is inhibited by the diaphragm, and a second position, in which flow of water  
25 from the valve inlet chamber to the valve outlet chamber is permitted by the  
diaphragm;  
wherein, the pilot inlet, when opened, effects movement of the diaphragm to  
its second position, and, when closed, effects movement of the diaphragm to its first  
position, and  
a blocking device including:  
30 a first member, and a second member including a blocking member  
for blocking the pilot inlet, wherein the first and second members are  
magnetically coupled such that movement of the first member causes  
movement of the second member;  
an actuator mechanically operable to effect movement of the first  
35 member to move the second member between first and second positions,  
wherein, in the first position, the second member urges the blocking  
member to block the pilot inlet, and, in the second position, the second

member holds the blocking member away from the pilot inlet so the pilot inlet is not blocked.

2. A water heater according to claim 1, wherein the blocking device includes a housing  
5 defining:
- a first space in which the first member is positioned; and
  - a second space for receiving the second member,
- wherein the first space is sealed with respect to the second space,  
and, optionally or preferably the second space is in fluid communication with the pilot  
10 chamber, preferably or optionally the second space opens into the pilot chamber.
3. A water heater according to claim 2 wherein the first member is configured to move  
linearly and / or the second member is configured to move linearly.
- 15 4. A water heater according to any one of claims 1, 2 or 3 wherein the first member is  
moveable between first and second positions which correspond to the first and second  
positions of the second member respectively, optionally or preferably including a biasing  
device for biasing the first member to its second position and optionally or preferably,  
when dependent directly or indirectly on claim 2, the biasing device is positioned in the  
20 first space.
5. A water heater according to any one of claims 1 to 4 wherein the first member  
includes one of a magnet or a magnetically susceptible material, and the second member  
includes the other of the magnet or magnetically susceptible material.
- 25 6. A water heater according to any one of claims 1 to 5 wherein the actuator includes a  
cam member and the first member includes a cam follower, wherein the cam member  
engages with the cam follower to effect movement of the first member, optionally or  
preferably the cam member is rotationally moveable, or the cam member is linearly  
30 moveable.
7. A water heater according to claim 6 wherein:
- g) the blocking device includes first and second stop elements;
  - h) the cam member includes a series of cam formations; and
  - 35 i) the cam follower includes a series of cam follower formations,
- wherein the blocking device, cam member and cam follower are configured such that,  
in a first configuration, the second stop elements engage with the cam follower formations  
to hold the first member in an extended position, and, in a second configuration, the

- second stop elements do not engage the cam follower formations and the first stop element engages with the cam formations to retain the first member in a retracted position, and optionally or preferably the first configuration corresponds to the first position of the first member and the second configuration corresponds to the second position of the first member.
- 5
8. A water heater according to claim 6 or 7 wherein operation of the actuator includes the cam member moving axially and movement of the cam member causes the cam follower to rotate, and/or optionally or preferably operation of the actuator causes the blocking device, cam member and cam follower to move from the first or second configuration to the other of the first or second configuration.
- 10
9. A water heater according to any preceding claim, wherein the water heater is an instantaneous water heater.
- 15
10. A hand wash unit or shower including a water heater according to any preceding claim.