

(No Model.)

2 Sheets—Sheet 2.

L. HUSSEY & E. McCANN.

DEVICE FOR REMOVING AIR FROM STEAM HEATING SYSTEMS.

No. 524,110.

Patented Aug. 7, 1894.

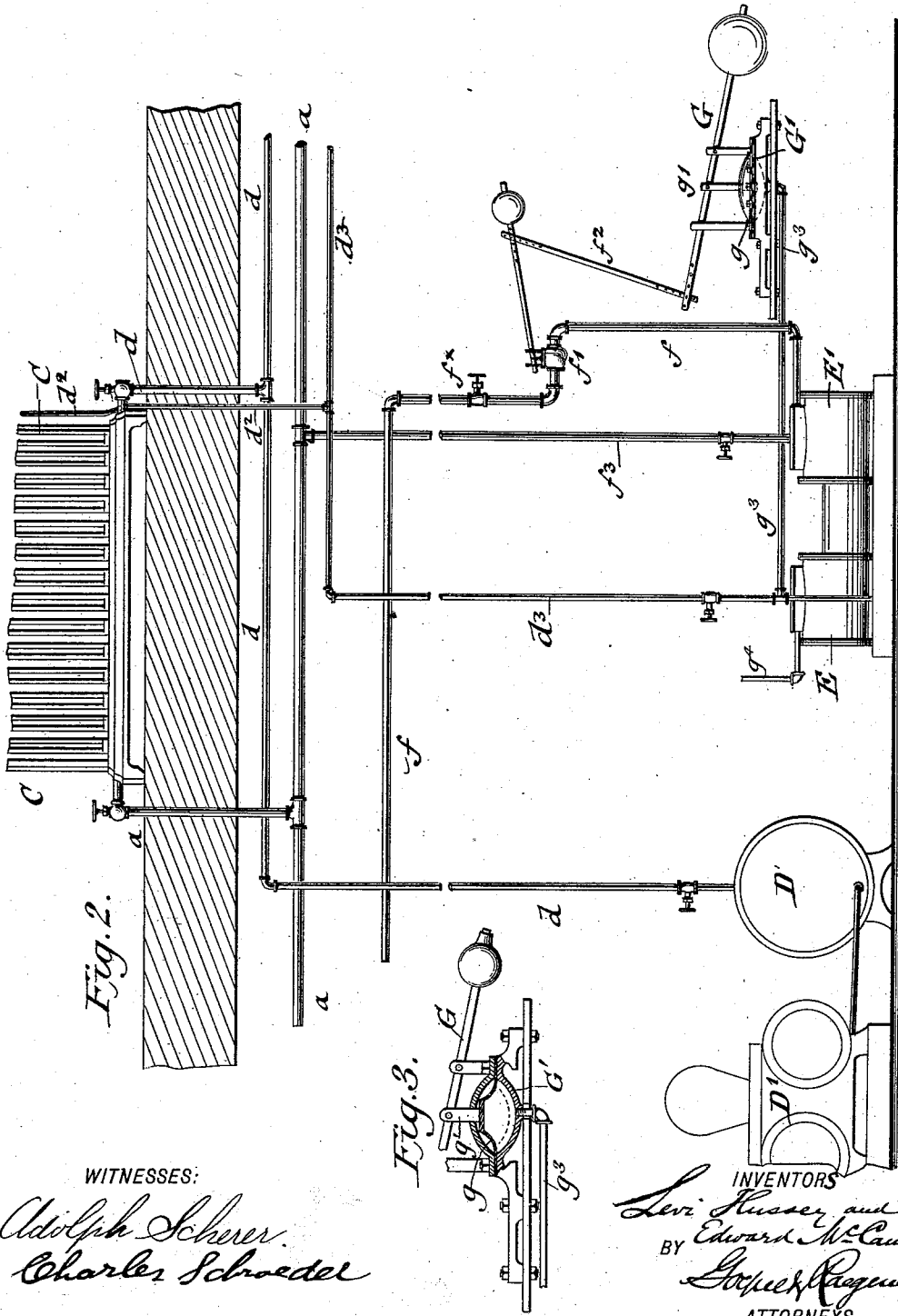

Fig. 2.

Fig. 3.

WITNESSES:

Adolph Scherer.
Charles Schroedel

INVENTORS

Levi Hussey and
Edward McCann
BY
Stephen Rogers
ATTORNEYS.

UNITED STATES PATENT OFFICE.

LEVI HUSSEY AND EDWARD McCANN, OF NEW YORK, N. Y.

DEVICE FOR REMOVING AIR FROM STEAM-HEATING SYSTEMS.

SPECIFICATION forming part of Letters Patent No. 524,110, dated August 7, 1894.

Application filed July 27, 1893. Serial No. 481,602. (No model.)

To all whom it may concern:

Be it known that we, LEVI HUSSEY and EDWARD McCANN, citizens of the United States, residing in the city of New York, in the county and State of New York, have invented certain new and useful Improvements in Devices for Removing Air from Steam-Heating Systems, of which the following is a specification.

In the steam-heating systems heretofore in use, the air in the radiators is generally permitted to escape through suitable air-valves which are connected with an air-pipe that leads to a suitable tank in which the escape-pipe is closed by a hydraulic seal. Considerable annoyance is caused in steam-heating by the presence of the air in the radiators, as thereby the quick and effective radiation of the heat is retarded and to some extent impaired, for the reason that the air in the radiators cannot be removed quickly enough when the steam is admitted to the same.

The object of our invention is to supply to steam-heating systems, in which radiators or coils for distributing the heat are used, a device by which the air in the radiators is quickly removed and discharged by means of an air-pump the working of which is automatically regulated by the steam or air, acting respectively indirectly or directly upon a flexible diaphragm whenever any one of the radiators or coils is connected with the supply of steam, so that the steam can quickly fill the entire radiator without being prevented from doing so by the body of air in the upper part thereof.

Our invention consists of a device for removing the air from the radiators or coils of steam-heating systems, which comprises an air-pump connected with the air-valves of each coil or radiator, said pump being automatically operated whenever any coil or radiator is connected with the steam-supply, by the opening of a balanced valve in the steam-pipe leading to the steam-cylinder of the air-pump so as to start the latter and remove the air from the coil or radiator, when the pump is stopped again by a suitable diaphragm connected with the balanced valve in the steam-pipe, as will be fully described hereinafter and finally pointed out in the claims.

In the accompanying drawings, Figure 1 represents an elevation of an ordinary steam-heating system with our improved device for removing the air from the coils or radiators of the same, and Fig. 2 is an elevation of our improved device for removing the air, drawn on a larger scale, and showing its connection with a radiator. Fig. 3 is a sectional view, partly in elevation, of the diaphragm-chamber and attached parts.

Similar letters of reference indicate corresponding parts.

Referring to the drawings, A represents a steam-boiler, from which the steam for heating a building is supplied. A pressure-reducing valve B is arranged in the steam-supply main a , which latter is connected in the usual manner with the coils or radiators C, by which the heat is distributed and emitted in the different parts of the building. Each coil or radiator C is connected with an exhaust-pipe d , by which the water of condensation and the uncondensed steam are returned to a tank D, from which the water of condensation is returned by a pump D' to the boiler in the usual manner. Each coil or radiator C is provided with an automatic air-valve d' that communicates with the upper part of the coil or radiator. The air-valves d' are connected by pipes d^2 with an air exhaust-pipe d^3 , and the latter is connected with an air-pump E that is operated by a steam-cylinder E', said pump and cylinder being of any approved construction. Live steam is supplied to the steam-cylinder by a pipe f leading from the steam main a .

The arrangement of the heating coils or radiators, and the connection of the same with the steam-boiler and the tank for receiving the water of condensation are well known and used in the steam-heating systems heretofore in use. They form therefore, no part of our invention, the new feature of which consists in the arrangement of an air-pump in connection with the air-valves of the different coils or radiators, and by means of which the pump is automatically started or stopped so as to remove in a reliable manner and effectively, the air from any of the coils or radiators and facilitate thereby the quick and effective dis-

tribution of the steam throughout the entire heating system.

The means by which the air-pump E is stopped and started consist of any suitable form of balanced valve f' in steam supply-pipe f leading to the steam-cylinder of the air-pump E, said valve being connected with a fulcrumed and weighted lever G. Lever G is connected to a spindle g' of a movable diaphragm g that is supported in a closed chamber G' , the lower part of which, below said diaphragm, is connected by a branch-pipe g^3 with the air-pipe d^3 leading to the air-pump, as shown clearly in Figs. 2 and 3.

A suitable discharge g^4 from the air-pump may lead off to the ash-pit, for instance, or to any other preferred place. A stop-valve f^x is arranged in the steam-supply-pipe f whereby the air-pump and the device for stopping or starting the same can be entirely cut off. The exhaust-steam is conducted from the steam-cylinder E' by an exhaust-pipe f^3 to the steam-main and used for heating the building.

Our improved device for removing the air from radiators, in steam-heating systems, operates as follows:—When the steam is turned on, and supplied at low pressure to the different coils or radiators of the heating system, the stop-cock f^x is turned on so that the steam can pass from the steam-main a to the steam-cylinder by which the air-pump E is operated. Whenever a coil or radiator is turned on and steam is supplied to the same, the air is exhausted through the air-valve d' of the same and drawn out of the air-pipes d^2 d^3 g^3 , and the space below the diaphragm g , so as to produce the lowering of the same, whereby the weighted lever G and its connection with the balanced valve f' is operated and the balanced valve is closed and the steam-supply shut off. The working of the pump exhausts the air from the coil or radiator and the pipes connected with the pump, and exerts thereby a suction-action on the diaphragm so that the weighted lever G is lowered and the steam-supply valve f' is closed. The working of the pump is thereby automatically interrupted until the next coil or radiator is connected with the steam-main. The air in the coil or radiator passing into the connecting air-pipes destroys the suction on the diaphragm, so that the return of the diaphragm into its normal position and its action on the weighted levers produce the opening of the balanced steam-valve and the supply of steam to the steam-cylinder of the air-pump, so that the latter is automatically started, which operation is continued until the air is removed from the radiator and its connecting pipes, so that the vacuum in the pipes and diaphragm chambers actuates the diaphragm and the connecting levers and shuts off thereby the supply of steam to the cylinder of the air-pump.

The advantages of our improved steam-

heating system are, first, by the automatic working of the air-pump, the air is quickly removed from any one of the coils or radiators of the heating system, so that the radiator is immediately capable of emitting heat from its entire radiating surface, as no air remains in any part of the coils or radiators by which the proper heating capacity of the same is impaired. Second, that the air-suction device is operated without loss of steam in a very simple and reliable manner, and the stopping and starting of the air-pump take place in a perfectly automatic manner. Third, the steam-heating system is adapted by the device for removing the air in the radiators in a higher degree, to the large buildings in which it is used.

Having thus described our invention, we claim as new and desire to secure by Letters Patent—

1. The combination, with the coils or radiators of a steam-heating-system, and the supply and return-pipes for the same, of an air-pump connected with the air-valves of the coils or radiators, a steam-cylinder for actuating said air-pump, and mechanism for automatically starting and stopping the air-pump, respectively when the steam is let into the steam-cylinder and when the air is exhausted by the pump, the same consisting of a steam-supply-valve in the supply-pipe of the steam-cylinder, a valve-controller connected with said steam-supply-valve, and means connected with the air-pump for automatically operating said valve-controller through the medium of air-pressure, whereby said supply-valve is automatically opened or closed to permit the pump to remove the air in the coils or radiators, substantially as set forth.

2. The combination, with the coils or radiators of a steam-heating-system, and supply and return-pipes for the same, of an air-pump, an air-suction-pipe connecting the air-valves of the coils or radiators, a steam-cylinder for said air-pump, a steam supply-pipe for said steam-cylinder, and mechanism for automatically starting and stopping the air-pump, respectively when the steam is let into the steam-cylinder and when the air is exhausted by the pump, the same consisting of a steam-supply-valve in the supply-pipe of the steam-cylinder, a valve-controller connected with said steam-supply-valve, and means connected with the air-pump for automatically operating said valve-controller through the medium of air-pressure, whereby said supply-valve is automatically opened or closed to permit the pump to remove the air in the coils or radiators, substantially as set forth.

3. The combination, with the coils or radiators of a steam-heating system and their supply- and return-pipes, of an air-pump, an air-suction-pipe connecting the pump with the air-valves of the coils or radiators, a steam-cylinder for said air-pump, a steam supply-

pipe for said cylinder, a balanced steam-supply-valve in said steam-pipe, a diaphragm-chamber connected with the air suction-pipe, a weighted lever connected with the spindle
5 of the diaphragm in said chamber, and a rod between the balanced steam supply-valve and the weighted diaphragm-lever, substantially as set forth.

In testimony that we claim the foregoing as our invention we have signed our names in presence of two subscribing witnesses.

LEVI HUSSEY.
EDWARD McCANN.

Witnesses:

PAUL GOEPEL,
CHARLES SCHROEDER.