

March 9, 1937.

W. STEPHENSON

2,072,909

PLATE CLAMP FOR PRINTING MACHINES

Filed June 22, 1932

3 Sheets-Sheet 1

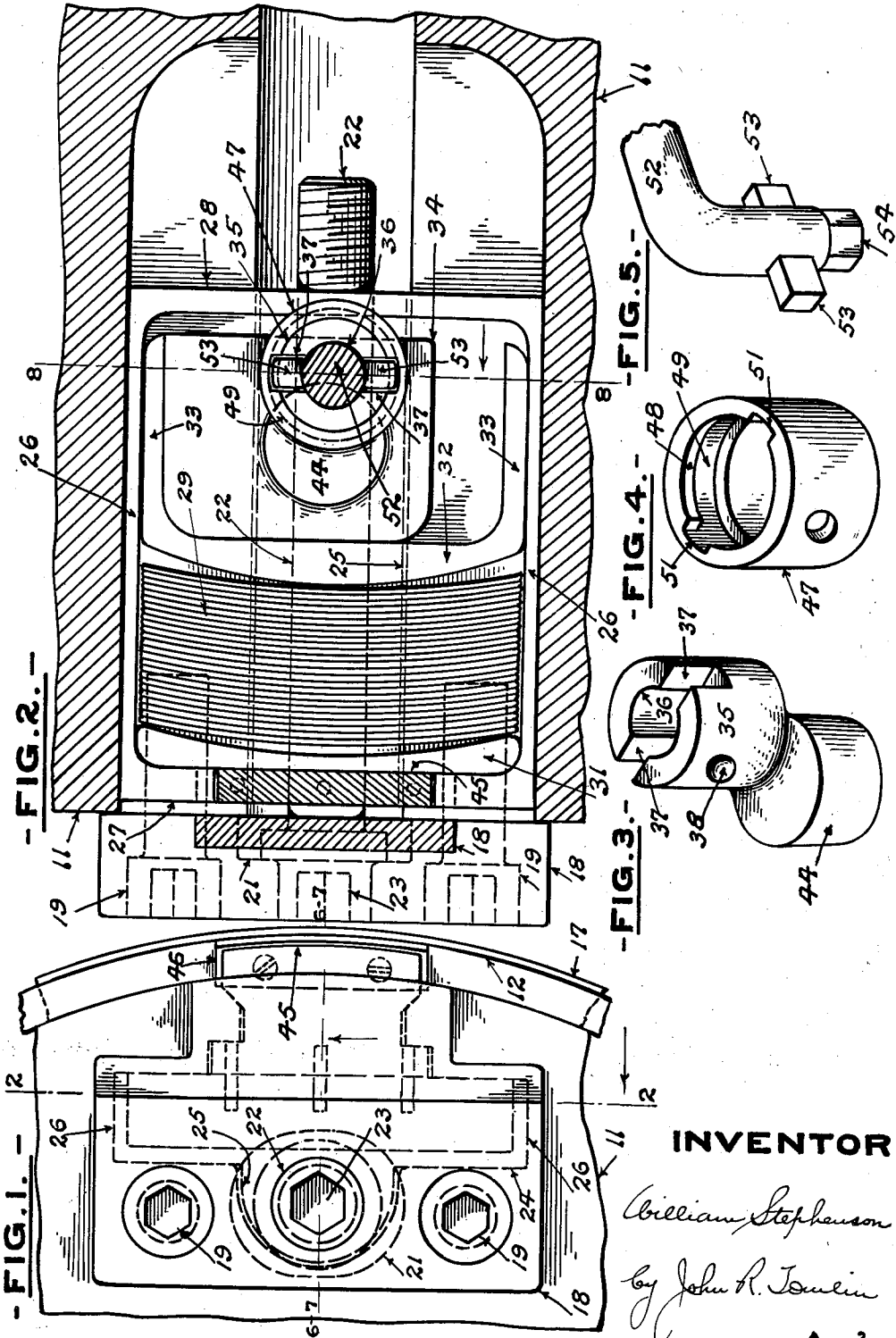

INVENTOR

*William Stephenson*

*by John R. Tomlin*

ATTY

March 9, 1937.

W. STEPHENSON

2,072,909

PLATE CLAMP FOR PRINTING MACHINES

Filed June 22, 1932

3 Sheets-Sheet 2

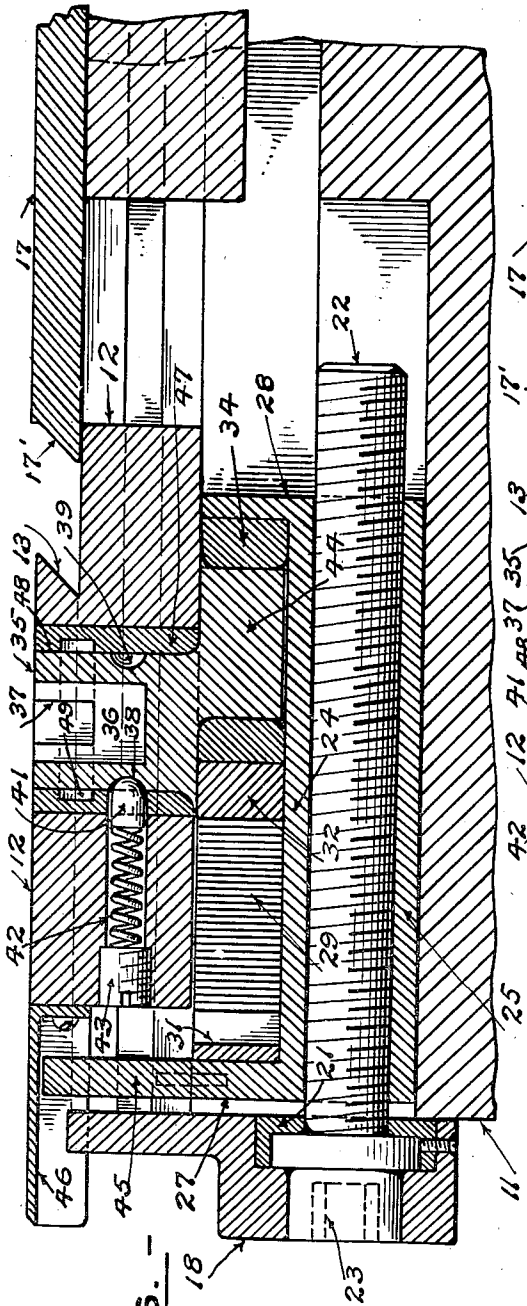

-FIG. 6.-

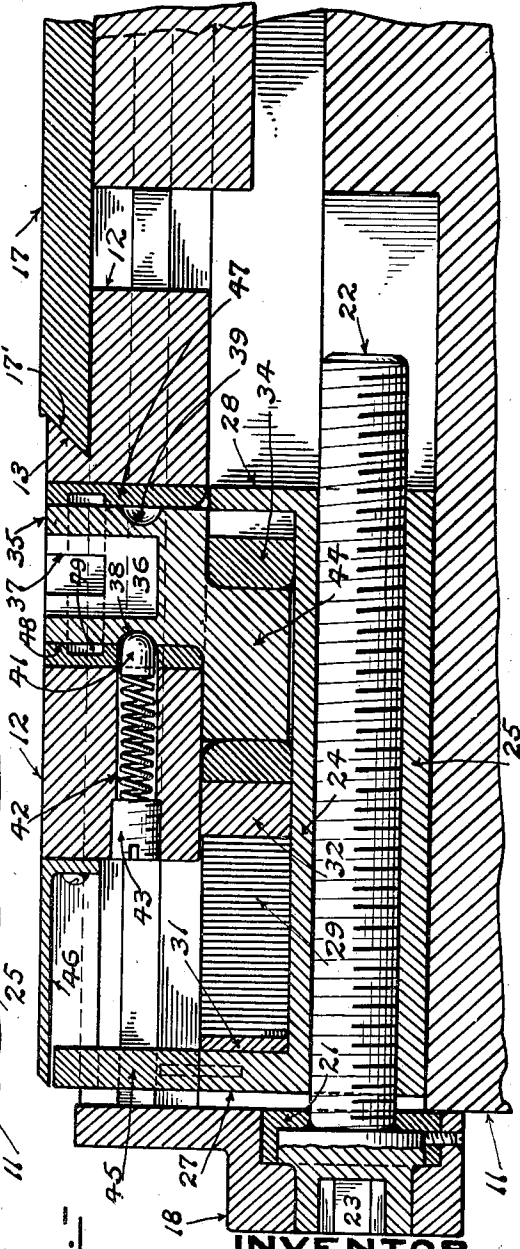

-FIG. 7.-

INVENTOR.

*William Stephenson*  
*by John R. Towne*

ATTY.

March 9, 1937.

W. STEPHENSON

2,072,909

PLATE CLAMP FOR PRINTING MACHINES

Filed June 22, 1932

3 Sheets-Sheet 3

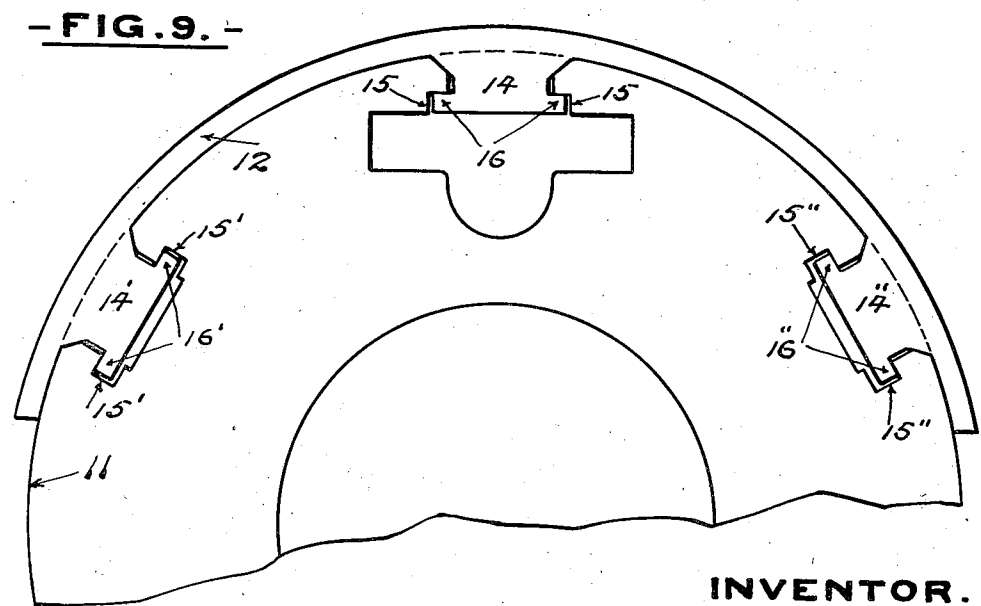
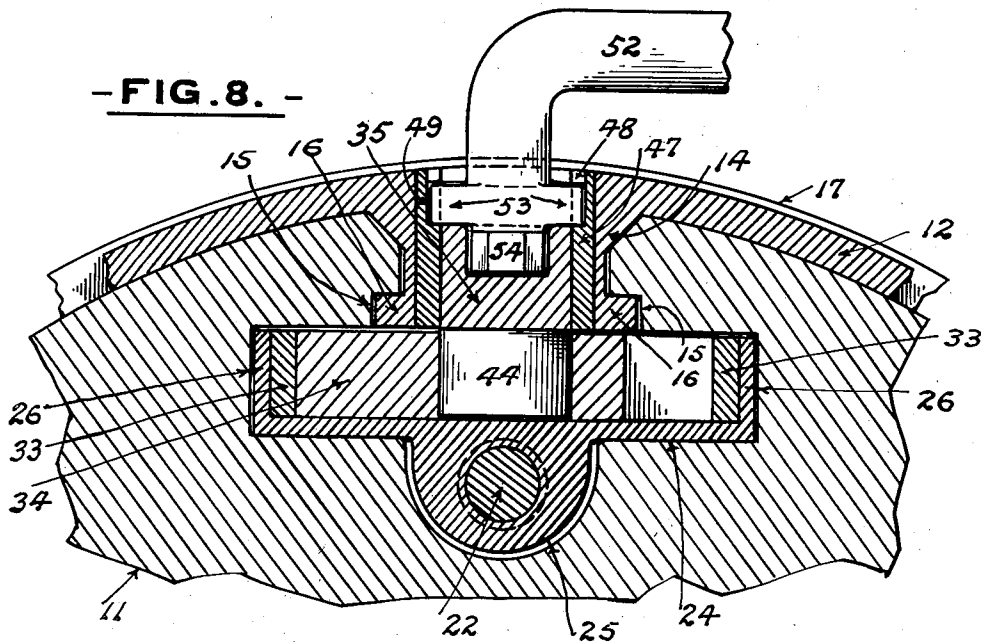

INVENTOR.

*William Stephenson*

*by John R. Joulin*

ATTY.

# UNITED STATES PATENT OFFICE

2,072,909

## PLATE CLAMP FOR PRINTING MACHINES

William Stephenson, Rutherford, N. J., assignor,  
by mesne assignments, to R. Hoe & Co., Inc.,  
New York, N. Y., a corporation of New York

Application June 22, 1932, Serial No. 618,651

20 Claims. (Cl. 101—378)

This invention relates to improvements in plate clamps adapted to secure stereotype or other printing plates on the cylinders of a rotary printing machine.

5 A stereotype plate for a rotary printing machine is usually made with its curved edges beveled or tapered, and adapted to be engaged by undercut clips slidably mounted on the printing cylinder and forced against the beveled edges  
10 of the plate by screws or other mechanical means which are fixed in position while the cylinder is stationary.

With the present high speeds the centrifugal and other forces caused thereby, result in loosening the plates due to their indentation or wear  
15 so that with clips once fixed in place, the plates, which are of comparatively soft type-metal, become loose and sometimes forcibly displaced resulting in accidents, damage and delay.

20 It is one of the objects of this invention to provide mechanical means for clamping the plates on the printing cylinder, and in addition to this, strong spring pressure is used to keep the plate clips in sufficiently forcible contact  
25 with the plates at all times when they are operatively mounted and in use.

By means of this invention the stereotype plates are held securely in place, and if their edges should be indented, for any reason, the  
30 constant spring pressure will cause the clips to follow them and compensate for this. Stereotype plates, especially from different trimming machines, are of slightly different dimensions between their clamping edges, but the mechanism  
35 of this invention provides quick and ready means for securing plates of different sizes and thus obviates delay or inconvenience on this account.

This invention provides a quick acting locking pin having a preferably integral crank pin,  
40 which is turned only about one-half a revolution to lock a plate in operative position, whereas the prior methods hereinbefore mentioned require a much longer time as they are dependent  
45 on the considerable travel of a screw or screws of small pitch necessitating many rotations thereof which are time consuming, and also inefficient for reasons previously explained.

In addition to the quick acting means for operating the plate clips, this invention also includes  
50 an adjusting screw to adapt the apparatus to promptly secure stereotype plates of considerably different dimensions between their clamping edges longitudinally of the printing cylinder.

The quick acting locking pin is operated by  
55 about a one-half turn of a hand wrench which is

easily moved during the major part of its rotation, but as its movement continues its eccentric or crank pin gradually deflects a powerful spring, and when the pin is locked in operative position  
5 the spring continues the pressure of the clip against the edge of the printing plate, regardless of whether the plate is indented or of slightly different width from the normal.

It will thus be seen that the mechanism of the present invention provides a speedy and simple  
10 movement for securing a plate on a printing cylinder, and the constant spring pressure is always working to maintain the pressure of the clip against the plate under all operating conditions notwithstanding the previous difficulties  
15 connected therewith as heretofore explained.

It is also an object of this invention to provide a plate clamping mechanism for printing machines of generally improved construction  
20 whereby the device is simple, durable and inexpensive to manufacture, as well as convenient, practical, serviceable and efficient in use.

With the foregoing and other objects in view, which will appear as the description proceeds,  
25 the invention resides in the combination and arrangement of parts and in the details of construction hereinafter described and claimed, it being understood that various changes in the  
30 precise embodiment of the invention herein disclosed may be made within the scope of what is claimed without departing from the spirit of the invention.

The preferred embodiment of the invention is illustrated in the accompanying drawings,  
35 wherein:

Figure 1 is an end elevation of part of a printing cylinder with this invention applied thereto;

Figure 2 is a sectional plan on the line 2—2 of Figure 1 looking in the direction of the arrow,  
40 and showing certain parts in their clamping positions;

Figure 3 is a perspective view of the operating stub shaft or locking pin and the eccentric or  
45 crank pin integral therewith;

Figure 4 is a perspective view of the sleeve or bushing in which the stub shaft or locking pin is  
rotatably mounted;

Figure 5 is a perspective view of the operating wrench or lever with part of its handle omitted  
50 for ease of illustration;

Figure 6 is a sectional elevation on the line 6—6 of Figure 1 looking in the direction of the  
arrow, with the moving parts shown in retracted or inoperative positions;

Figure 7 is a view similar to Figure 6 taken on

the line 7—7 of Figure 1 looking in the direction of the arrow but with the moving parts in projected or closed and operative positions;

Figure 8 is a cross section on the line 8—8 of Figure 2 looking in the direction of the arrow, with the wrench in elevation, and

Figure 9 is an end elevation of part of a printing cylinder showing the manner of mounting the plate clip thereon.

Referring now to the characters of reference on the drawings:—

Part of a printing or form cylinder of a rotary printing machine is indicated as 11, the plate clip slidably mounted therein is 12, the undercut plate engaging edge of which is 13.

It should be noted that the plate clip is arcuate and extends around almost half of the plate cylinder and other similar clips, not shown, complete this part of the equipment to hold a plurality of plates thereon.

Intermediate clips are also used as customary to hold the inner edges of the plates. The arcuate clip 12 has a center slide portion 14 mounted in the printing cylinder 11 in the rabbets 15 and is retained by its tongues 16, and, in addition to this, the clip 12 has similar end slides 14' and 14'' the tongues 16' and 16'' of which are mounted in the rabbets 15' and 15'' respectively.

Part of the printing plate is indicated as 17 and its beveled edge against which the clip is adapted to engage is 17'.

The mechanism of this invention is preferably applied to the central portion and slide 14 of the arcuate clip 12 as illustrated, and operates the entire clip thus requiring a minimum of apparatus, time and labor in use.

A front or clip plate 18 is provided and is fixedly secured on the end of the cylinder by the two socket head cap screws 19.

A spring box or container 24 has a lower or inner boss 25 as shown, which is internally threaded, and rotatably mounted therein is the threaded adjusting screw 22 having a thrust collar as shown and is retained in the clip plate 18 by the bushing 21.

This adjusting screw has a socket 23 in its head and can be turned by inserting the hexagon end 54 of the wrench 52 therein, thus adjusting the positions of the parts connected therewith.

This adjustment is not used when the different printing plates are of substantially uniform sizes, and it is only necessary to use this adjustment to accommodate the mounting of plates of varying sizes.

The spring container 24 is made in the form of an open top rectangular box as illustrated, with sides 26, front end 27 and rear or inner end 28.

In this box is mounted a spring 29 preferably composed of a plurality of steel plates or leaves as shown, and in order that these shall best function they have an initial set or curvature, when free, opposite to that illustrated in Figure 2. In other words, the spring 29 when free would have its convex side nearer to the center of the printing cylinder and its concave side nearer to the end of the cylinder, whereas when in use and flexed as illustrated in Figures 2 and 7 the curvature is reversed as shown.

This provides the maximum spring pressure for operation with the minimum size of spring and attachments.

A front bearing plate or abutment 31 is provided which bears against the ends of the leaves of the spring and allows its deflection while on

the other side of the spring a curved follower plate 32 is provided and adapted to press centrally of the spring. This is provided with wings or guides 33 adapted to slide along the spring box sides 26 and thereby insure its correct axial movement.

Mounted in the spring box is a thrust member or locking plate 34 having a cylindrical hole nearer to one end as shown. Rotatably mounted in the plate clip 12 and its center slide portion 14 is a locking member or pin 35, having a cylindrical socket 36, and slots 37 connecting therewith, and it is also provided with recesses 38 and 39 to receive the end of the plunger pin 41, which is adapted to be projected by the spring 42 that is held in place by the slotted screw 43 as illustrated, and this yieldably locks the parts in forward or in the rear positions.

A crank pin or eccentric 44 is preferably formed integral with the locking pin 35, and is seated in the cylindrical hole in the locking plate 34 and is thus adapted to move it by the revolution of the locking pin 35.

Secured to the front end 27 of the spring box is the indicator plate 45 which is held in place by the dowel pins as shown or it may be made integral with the front end 27 of the spring box if preferred. Above this and mounted on the plate clip 12 is the indicator 46, which when its end is flush with the indicator plate 45 as illustrated in Figure 7, shows that the printing plate is properly locked in position.

The locking pin 35 is mounted in the bushing 47 which is provided with a top annular collar 48 having an annular space 49 below it and is further provided with the slots 51 in its opposite sides.

These slots are adapted to permit the introduction and withdrawal of the lug wrench 52 having the opposed lugs 53 and the hexagon end 54.

The lug wrench can only be entered or withdrawn when the slots 51 and 37 are in registry, which is the case when the plate clip is either in its securely locked or in its fully open position and so yieldingly held by the locking pin 41 in the recess 39 or 38 respectively. The hexagon end 54 of the wrench is adapted to fit in the socket 23 in the head of the adjusting bolt 22 so that one tool only is necessary to operate the devices of this invention.

The mechanism when located as illustrated in the drawings forming part hereof is adapted for use at that end of the printing cylinder where it is shown on account of its convenience for the operator and the position of the wrench for his easy manipulation.

This same mechanism is also used at the other end of the printing cylinder, and all that is necessary to do to adapt it to this use, is to turn the locking block 34 over or upside down.

This makes the clamping mechanisms right and left respectively, and each is best adapted for easy use by the operator.

Having thus described the apparatus, a further description of its features, adaptability and mode of operation will now be presented:—

When the various parts of the mechanism are in the locations illustrated in Figure 6 they are in the fully retracted or unlocked positions and the spring 29 exerts only its lesser initial pressure.

In this case, as may be seen in Figure 6, the locking pin 35 has been rotated to move the plate clip 12 to the left and a considerable gap or space exists between the undercut surface 13

of the plate clip 12 and the beveled edge 17' of the printing plate 17.

It should also be noted that at this time, the plunger pin 41 is seated in the recess 38 of the locking pin 35 to yieldingly hold the parts in positions shown. In addition to this it will also be seen in Figure 6 that the indicator 46 projects outwardly a considerable distance beyond the indicator plate 45 and this is easily discovered either by sight or touch, showing plainly that the printing plate is fully unlocked.

When the locking mechanisms are in the positions shown in Figure 6 a printing plate 17 is manually located in the position shown, whereupon the end of the wrench 52 is inserted in the socket 36 of the locking pin 35 with its lugs 53 in the slots 37 after passing through the slots 51 in the collar 48 of the bushing 47.

This may be done by the same operator who has just placed the printing plate 17 in position on the cylinder 11, with its other bevel edge against another clip, not shown.

The wrench handle is then turned about one-half a revolution, until its lugs 53 register respectively with the other slots 51 in the collar 48 of the bushing 47 whereupon the wrench can be withdrawn. It should be noted that the lug wrench can only be inserted when the clip 12 is unlocked or fully locked.

As the locking pin 35 and the crank pin 44 are integral, and relatively eccentric the partial rotation of the locking pin 35 will also partially revolve the crank pin or eccentric 44. As the partial rotation and revolution proceeds the plate clip 12 is projected by the movement of the locking pin 35, until its undercut edge 13 engages the beveled edge 17' of the printing plate 17, and simultaneously the eccentric 44, which is integral with the locking pin tends to move toward the outer end of the cylinder.

As however this latter movement is resisted by the pressure of the spring 29 the first effect is to project the undercut part 13 of the clip 12 against the bevel edge 17' of the printing plate 17, and after this is done the continuation of the movement bends the spring until it assumes the flexed shape shown in Figure 2 when the parts are in positions shown in that figure and in Figure 7.

The arrangement and proportions of the parts are such that when in locked position the axis of the locking pin 35 is slightly past the longitudinal center line through the axis of the eccentric 44 as may be seen in Figure 2, while the locking plate 34 is abutting the guide 33, thus securely holding the printing plate in place as shown in Figure 7. At such a time the spring 29 is compressed and constantly maintains the pressure of the clip 12 against the printing plate 17 and even if the latter should be indented by the forces due to its rotation or vibration the spring will cause the clip to follow up and continue its contact with the plate with a substantially constant and predetermined force. The spring and other parts are so designed that this clamping force is always of substantially the degree required or necessary to best accomplish the purpose.

The indicator 46 is so designed and proportioned that when its beveled edge is flush with the indicator plate 45, as shown in Figure 7, the parts are in position to produce the desired clamping pressure, and the indicator may be both visually and tangibly inspected by the op-

erator to assure himself that the parts are properly operative, with the printing plates properly secured so that it is safe to start the rotation of the printing cylinder.

Should the edge of the bevel of the indicator 46 be not flush with the face of the indicator plate 45 as determined by sight if light is good or by touch if in semi-darkness, the end 54 of the wrench 52 is inserted in the socket 23 of the adjusting bolt 22 and turned until the edge of the indicator is flush with the indicator plate 45, whereupon the parts are positioned to produce the desired clamping pressure.

Should successive printing plates be of different dimensions longitudinally of the printing cylinder, the adjusting bolt 22 may be turned to compensate for this, in order to maintain the desired clamping pressure.

The adjusting screw 22 or a longer one than shown can be used to accommodate the mechanism of this invention to clamp printing plates of any sizes dependent on the widths of paper used to produce the printed products.

This adjusting screw 22 can also be used before or after the locking pin 35 and its attachments are operated to quickly clamp a plate and this can be done in a few seconds to properly accommodate printing plates of any widths.

It should also be noted that the forward projection of the plate clip 12 by the operation of the locking pin 35 and eccentric 44 is accomplished speedily in its first stages with little resistance, but, when the clip is about to engage with the plate, the leverage is greater, thus providing increased force when it is necessary.

The size and strength of the spring 29 are determined, and the pressure applied to the printing plates thereby is also arranged by the design and proportion of the parts, so that only a sufficient and substantially predetermined pressure is used.

By so doing, the plates are held firmly and securely, but can not be distorted or buckled as heretofore by undue pressure applied to a clamping screw or screws as sometimes occurs, with prior devices, due to haste, ignorance or excessive force applied to the screw by the operator.

By means of this invention all the plates on the printing cylinders can be clamped with substantially the same or desired pressures, thus eliminating the personal equation and therefore obviating the difficulties with certain prior devices as mentioned herein.

When a plate is locked in position as above described and illustrated in Figures 2 and 7 and it is desired to remove it, the wrench is inserted in the locking pin 35 and turned in a direction reverse of that used for clamping, whereupon the plate clip is promptly retracted allowing the printing plate to be removed and replaced by another one in the manner previously indicated.

As the locking pin and spring clamping arrangement in connection therewith can be operated in a few seconds by the quick turn of a wrench, it can thus be seen that this mechanism is both a time and labor saver as compared to other methods and this of course is a desideratum.

What I claim is:

1. The combination with a printing cylinder having a printing plate thereon, of a plate clip slidably mounted on the cylinder, a locking pin rotatably mounted in the clip, an eccentric forming part of the locking pin, a spring carried by the cylinder and adapted to be flexed by the eccentric, and means for rotating the locking pin

whereby the plate clip is projected and engages the printing plate with a yielding pressure.

2. A printing cylinder, a plate clip slidably mounted thereon, a locking pin mounted in the clip, a crank on said pin, means for rotating said pin, thereby revolving the crank and reciprocating said pin and clip, a bearing for said crank, and a spring connected to said cylinder, said spring being flexed by the movement of said crank.

3. The combination with a printing cylinder having a printing plate mounted thereon, of a plate clip adapted to engage the printing plate, said clip being slidably mounted on said cylinder, a locking pin rotatably mounted in said clip, an eccentric on said pin, a spring connected to said cylinder and said eccentric, and means for rotating said pin to thereby project said clip, whereby said eccentric flexes said spring, causing said clip to hold the printing plate with yielding pressure.

4. A printing cylinder having a printing plate, a plate engaging clip slidably mounted thereon, a container mounted in said cylinder, a screw rotatably mounted in said cylinder and threaded in said container adapted to adjust their relative positions, a spring in said container, a locking pin rotatably mounted in said clip, an eccentric on said locking pin, a spring carried in said container, a locking plate in said container in which said eccentric is rotatably mounted and adapted to flex said spring, and means for rotating said locking pin, whereby the spring is flexed as the plate clip is forwardly projected into engagement with the printing plate.

5. A printing cylinder having a plurality of grooved slots extending longitudinally thereof, a printing plate with beveled clamping edges mounted on said cylinder, an arcuate plate clip with an undercut edge adapted to engage the printing plate, a plurality of slides on said clip mounted in the slots aforesaid, a locking pin rotatably mounted in said clip and the central slide thereof, an eccentric on said pin, a bearing in which said eccentric is mounted, a spring associated with said bearing, and means for rotating said pin adapted to project and retract said clip, whereby the spring is flexed by the eccentric during the forward projecting movement, thereby causing the clip to engage the printing plate with a substantially predetermined but yielding spring pressure.

6. A printing cylinder having a plurality of grooved slots extending longitudinally thereof, a printing plate with beveled clamping edges mounted on said cylinder, an arcuate plate clip with an undercut edge adapted to engage the printing plate, a plurality of slides on said clip mounted in the slots aforesaid, a locking pin rotatably mounted in said clip and the central slide thereof, an eccentric on said pin, a bearing in which said eccentric is mounted, a spring associated with said bearing, a screw rotatably secured to said cylinder and adapted to longitudinally adjust said bearing, and means for rotating said pin adapted to project and retract said clip, whereby the spring is flexed by the eccentric during the forward projecting movement, thereby causing the clip to engage the printing plate with a substantially predetermined but yielding spring pressure.

7. A printing cylinder having a plurality of grooved slots extending longitudinally thereof, a printing plate with beveled clamping edges mounted on said cylinder, an arcuate plate clip with an undercut edge adapted to engage the printing

plate, a plurality of slides on said clip mounted in the slots aforesaid, a locking pin rotatably mounted in said clip and the central slide thereof, means for securely locking said pin in its projected position and for yieldably locking it in its retracted position, an eccentric on said pin, a container carrying a bearing in which said eccentric is mounted, a spring associated with said bearing, a screw rotatably secured to said cylinder and threaded in said container, and means for rotating said pin adapted to project and retract said clip, whereby the spring is flexed by the eccentric during the forward projecting movement, thereby causing the clip to engage the printing plate with a substantially predetermined but yielding spring pressure.

8. In a rotary printing machine, a printing cylinder, a plate clip slidable longitudinally of the cylinder, a rotatable locking member movable with the clip, an eccentric on the locking member, a spring, an abutment for the spring adjustable longitudinally of the cylinder, and a thrust member engaging the eccentric and operably connected to the spring.

9. In a rotary printing machine, a printing cylinder, a plate clip slidable longitudinally of the cylinder, a rotatable locking member movable with the clip, an eccentric on the locking member, a thrust member engaging the eccentric, an abutment secured to the cylinder, and a multiple leaf spring operably connected between the thrust member and the abutment.

10. In a rotary printing machine, a printing cylinder, a plate clip slidable longitudinally of the cylinder, a rotatable locking member movable with the clip, an eccentric on the locking member, a thrust member engaging the eccentric, an abutment secured to the cylinder and adjustable longitudinally thereof, and a multiple leaf spring operably connected between the thrust member and the abutment.

11. In a mechanism for clamping stereotype plates to a form cylinder, a plate clip longitudinally movable on said form cylinder, a container positioned within said cylinder, a laminated spring within said container, a slidable thrust member engaged by said spring, and manually actuated means engaging said plate clip and thrust member to project said plate clip and simultaneously flex said spring, whereby a yielding pressure is exerted upon the plate clip when projected into engagement with a plate.

12. The combination with a printing cylinder having a printing plate thereon, of a clip longitudinally slidable on the cylinder, means for projecting the clip to engage and lock said printing plate on the printing cylinder, an indicator secured to the end of the plate clip and longitudinally movable therewith and an indicator plate, relatively stationary with respect to said clip, cooperating with said indicator to determine by their relative positions the correctness of the clip engagement with said printing plate.

13. In a mechanism for clamping stereotype plates to a form cylinder, a plate clip longitudinally movable on said form cylinder, a container arranged within said cylinder, means to adjust the position of said container longitudinally of said cylinder, a manually rotatable locking pin positioned within said clip and having an eccentric portion positioned within said container, and a spring in said container associated with said eccentric portion, whereby upon rotation of the locking pin, said plate clip is moved into clamped engagement with the plate and is maintained in

yielding spring pressed engagement therewith by the cooperative action between the eccentric and spring.

14. In a mechanism for clamping stereotype plates to a form cylinder, a plate clip longitudinally movable on said form cylinder, a container arranged within said cylinder, means to adjust the container longitudinally of the cylinder, a spring within said container, a thrust member within said container, a manually rotatable locking pin positioned within said clip, and an eccentric portion on said locking pin positioned within said thrust member, whereby upon rotation of the locking pin, the thrust member is moved backward by the eccentric against the pressure of the spring and the plate clip is moved forward into yieldable engagement with the plate.

15. In a plate clamping mechanism for a printing machine, a plate engaging member slidable into and out of plate clamping position, resilient means operatively associated with said member and arranged to urge the same into plate clamping position, means carried by said plate clamping member and adapted to move it toward and away from plate clamping position, and means to adjust said member relatively to the plate when in plate clamping position.

16. In a plate clamping mechanism for a printing machine, a plate engaging member slidable into and out of plate clamping position, resilient means operatively associated with said member and arranged to urge the same into plate clamping position, means carried by said plate engaging member to move said plate clamping member toward and away from plate clamping position, means to adjust said member relatively to the plate when in plate clamping position, and means to indicate the amount of such adjusting movement.

17. In a plate clamping mechanism for a printing machine, a plate engaging member slidable into and out of plate clamping position,

resilient means operatively associated with said member and arranged to urge the same into plate clamping position, means carried by said plate clamping member and adapted to move it toward and away from plate clamping position, and means to increase and decrease the tension of said resilient means when said member is in plate clamping position.

18. In a mechanism for clamping plates to a cylinder of a printing machine, a plate clamping member longitudinally movable relatively to said cylinder, a part disposed in said cylinder and movable relatively to said member, a spring mounted in said cylinder in engagement with said part, and operable means in said cylinder in operative engagement with said part through said spring and in engagement with said member to move said member into and out of plate clamping position.

19. In a device for clamping a plate on a cylinder of a printing machine, a plate clip slidably mounted on the cylinder, a resilient member, a part rotatably secured to said plate clip, and mechanism affected by said resilient means to press said plate clip against the plate and cooperating with said part upon rotation thereof to move said plate clip toward and away from the plate.

20. In a mechanism for clamping plates to a cylinder, a plate clamping clip longitudinally movable relatively to said cylinder, spring pressed means in said cylinder, a member rotatably mounted to and longitudinally movable with said clip, a part of said member being eccentric thereto and in operable association with said spring pressed means, and means to rotate said member in one direction, to move said clip and said spring pressed means in opposite directions, to clamp the plate to said cylinder, and to compress said compressible means.

WILLIAM STEPHENSON.