

Nov. 26, 1935.

C. R. JERRY

2,022,316

METALLIC INLAY DECORATION FOR SPECTACLE CASES

Filed Oct. 12, 1934

2 Sheets-Sheet 1

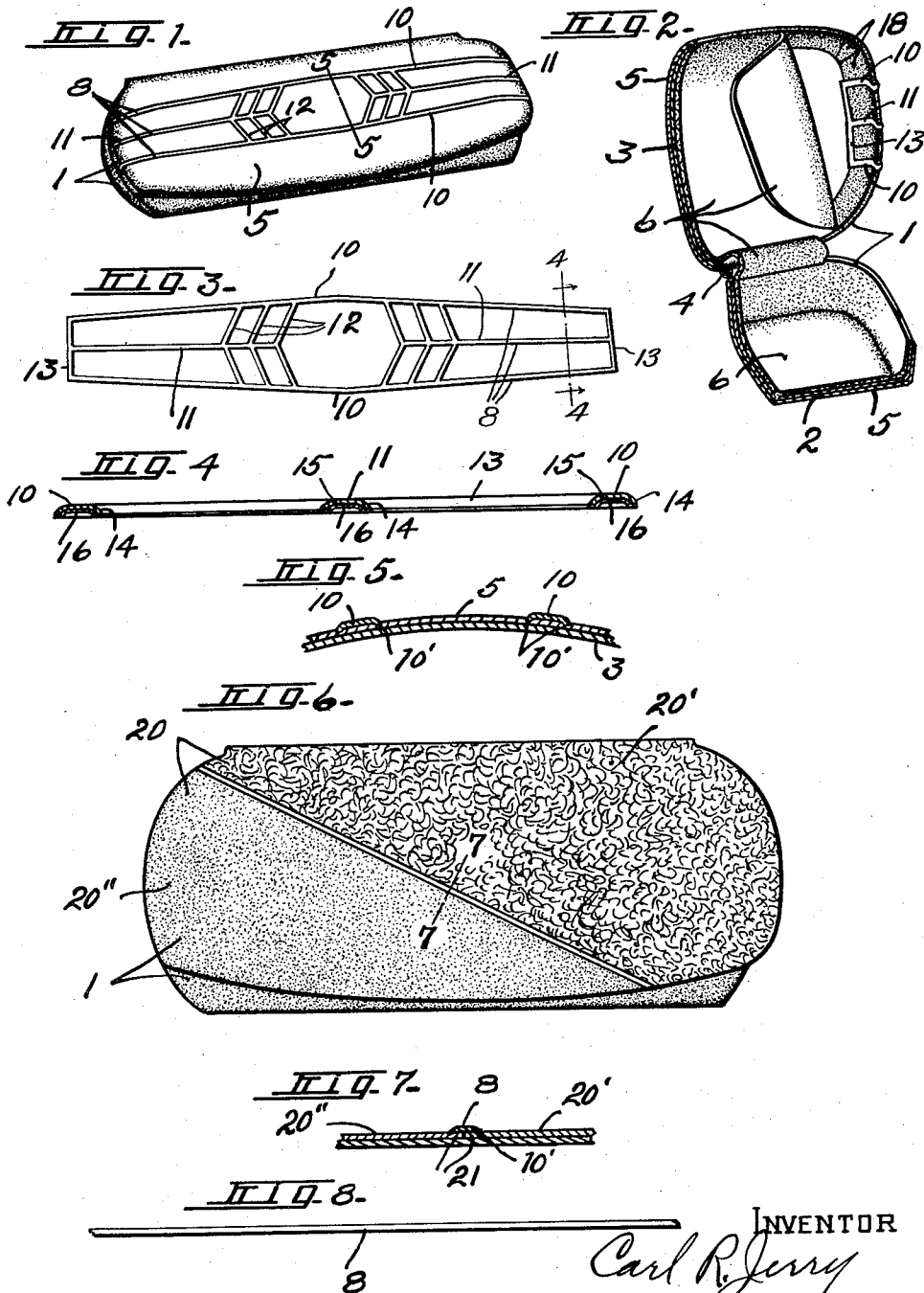

WITNESS  
*J. J. Mains*

INVENTOR  
*Carl R. Jerry*  
BY  
*Hoguet and Neary*  
ATTORNEYS

Nov. 26, 1935.

C. R. JERRY

2,022,316

METALLIC INLAY DECORATION FOR SPECTACLE CASES

Filed Oct. 12, 1934

2 Sheets-Sheet 2

FIG. 9.

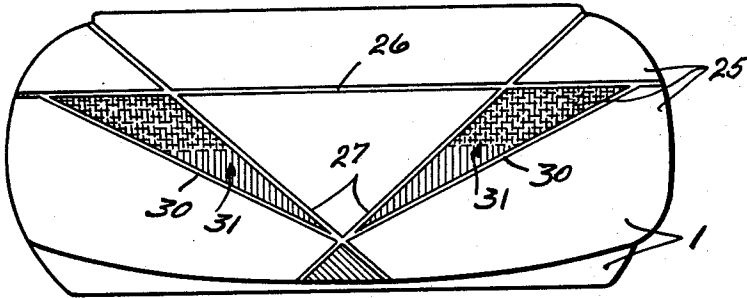

FIG. 10.

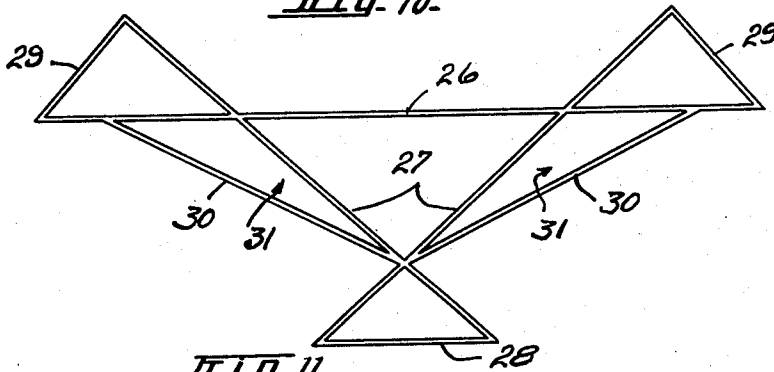

FIG. 11.

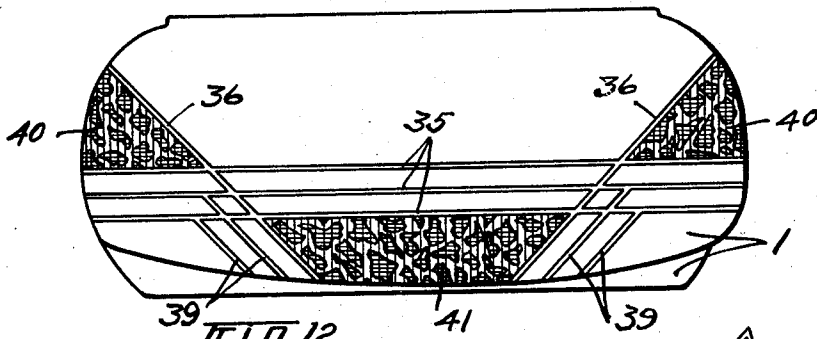
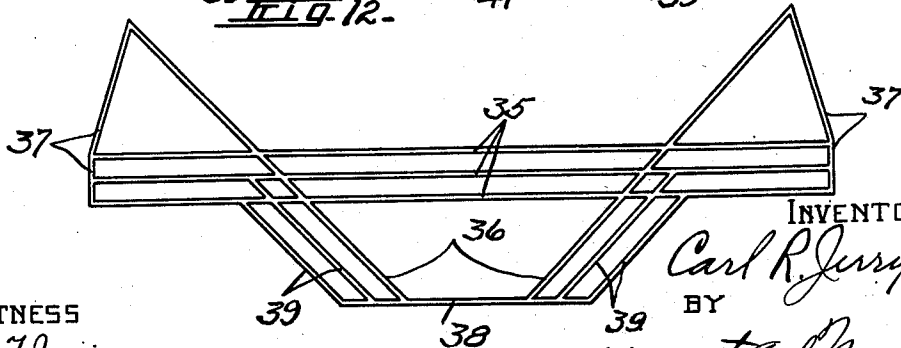

FIG. 12.



WITNESS  
*J. J. Mains*

INVENTOR  
*Carl R. Jerry*  
BY  
*Hoguet and Neary*  
ATTORNEYS

# UNITED STATES PATENT OFFICE

2,022,316

## METALLIC INLAY DECORATION FOR SPECTACLE CASES

Carl R. Jerry, Rochester, N. Y., assignor to Shuron Optical Company, Inc., Geneva, N. Y., a corporation of New York

Application October 12, 1934, Serial No. 748,108

17 Claims. (Cl. 41—34)

This invention relates to a decorated spectacle case and pertains more particularly to a decorative element for the case and to the manner of applying the same thereto.

The main object of my invention is to provide a spectacle case or the like with simple and inexpensive decoration means that may be quickly and easily applied to the conventionally constructed case.

Another object of the invention is to provide a case structure of the above mentioned class comprising a flexible covering composed of a plurality of pieces arranged in juxtaposed relation and to provide a decorative element that may be readily applied to the case in such a manner as to join and conceal the adjacent edges of the covering.

A further object of the invention resides in providing a decorative element for a case comprising metallic members which, although partially imbedded in the covering for the case member, will have the appearance of being fully inlaid.

Still another object of the invention resides in producing a decorative element for spectacle cases or the like having a structure which is readily applicable to a multiplicity of different designs.

Other objects and advantages pertaining to the construction of the decorative element and to the manner of applying the same to a spectacle case all of which will more fully appear from the following description taken in connection with the accompanying drawings in which:—

Figure 1 is a perspective view of a spectacle case having a decorative element embodying the various features of this invention associated therewith.

Figure 2 is a fragmentary perspective view illustrating one end of a spectacle case in the open position and a portion of the inner lining of the cover thereof folded backwardly to better illustrate the underlying structure.

Figure 3 is a top plan view of the decorative element illustrated in Figure 1.

Figure 4 is an enlarged transverse sectional view taken on line 4—4, Figure 3.

Figure 5 is an enlarged transverse sectional view taken on line 5—5, Figure 1.

Figure 6 is a top plan view of a spectacle case illustrating a modified form of an outer case covering together with a modified form of my novel decorative element.

Figure 7 is an enlarged detail sectional view taken on line 7—7, Figure 6.

Figure 8 is a top plan view of the decorative element illustrated in Figure 6.

Figure 9 is a plan view of a spectacle case illustrating a further modified form of decorative element.

Figure 10 is a plan view of the decorative element illustrated in Figure 9 before the same has been applied to the case.

Figure 11 is a plan view of a spectacle case illustrating a still further modified form of decorative element applied thereto.

Figure 12 is a plan view of the decorative element illustrated in Figure 11 before the same has been applied to the case.

As illustrated in Figures 1, 2 and 5 of the drawings, the spectacle case as **1** is composed of a substantially rectangular body portion **2** and a cover portion **3**, both of which are preferably composed of sheet metal stampings and are hinged together along one longitudinal edge thereof as at **4**, Figure 2. The body and cover members, as shown in Figure 2 are provided with the usual pliable outer covering **5** composed preferably of leather or a manufactured fabric of a cloth base covered with one or more coatings of what is commonly called pyroxylin or other plastic material which is then embossed or treated to obtain various colors and designs or grains.

The case is also shown as being provided with a lining **6** in the conventional manner and which may be composed of any suitable material such as plush, velvet or the like.

The hereinbefore mentioned decorative element for the case is of the nature of an inlay comprised of one or more thin relatively narrow metallic bars or strips **8** composed preferably of zinc and chromium plated on one side. However, I do not wish to be limited to any specific class of material as it is obvious that various other flexible materials, such as aluminum, chromium or nickel plated brass or the like may be readily used.

These bars or strips may be cut or stamped from a sheet of suitable material and arranged to form a multiplicity of suitable designs, depending upon the desire and skill of the designer. For instance, in Figures 1 and 3, I have illustrated one design of my novel inlay or decorative element and which is of substantially rectangular outline comprising a pair of longitudinally extending side bars **10** of greater length than that of the case member to which the inlay is to be applied. These side bars **10** are arranged in transverse spaced relation and intermediate longitudinally extending bars **11** are arranged

between the side bars 10 in longitudinal alignment with their inner ends terminating in spaced relation substantially midway between the ends of the side bars 10.

5 The inner end portions of the intermediate bars 11 are connected to the side bars 10 by obliquely disposed cross bars 12. The adjacent ends of the longitudinal bars are tied together by a cross bar 13 which, it will be noted, will maintain adjacent end portions of the longitudinal bars in predetermined fixed relation.

10 As illustrated more particularly in Figure 4, each longitudinal bar and cross bar is formed slightly concaved by the turning of the longitudinal edges thereof laterally away from the plated or outer surface of the bar as at 14 which not only aids in securing the inlay to the case as will hereinafter be more apparent, but also provides a recess 15 for the reception and maintenance of suitable adhesive that is applied to the inner surface of the bar 12 as illustrated at 16. This inlay is applied to the case during the process of manufacture of the case in the following manner.

25 The case body 2 and cover 3 are first formed in the usual manner from sheet metal by stamping or other suitable means and then these members are secured together as by hinge means 4. The outer covering 5 is cut to the proper outline and treated with a suitable adhesive such as gutta percha by the application thereof to the inner surface of the covering. The covering is then fitted to the case in the conventional manner by manually applying the same to first the outer surface of the body 2 and then to the outer surface of the covering 3 after which the marginal edge of the covering is folded inwardly about the marginal edge of these case members as illustrated at 18, Figure 2.

40 The inlay is then placed over the outer covering of either the body portion or cover portion or both, as desired, and the ends of the inlay are folded inwardly about the adjacent edge of the case member.

45 It will at this point be observed that inasmuch as the length of the side bars 10 is greater than that of the case member, as previously stated, the end tie bars 13 are positioned as illustrated in Figure 2 within the case member, as the cover 3, adjacent the marginal edge 18 of the covering 5 and will maintain the adjacent portions of the longitudinal bars 10 and 11 in predetermined spaced relation during and after the folding of the ends thereof about the marginal edge of the cover. The case is then placed in a conventionally constructed cover applying apparatus which includes a heated die that presses the covering into close contact with the outer surface of the body and cover and with the marginal and inner edges of the case. At the same time the heat of the die renders the adhesive carried by the covering material effective so that the covering is securely mounted on these metal case members.

65 It will now be understood that the inlay will receive the same treatment from the die as the case covering and will thereby be securely fixed to the case simultaneously with the outer covering and without the necessity of any change or alteration being made to the cover applying mechanism.

70 In other words, the die member will press the inlay into close contact with the outer case cover and the heat of the die will render the adhesive carried by the inlay effective for firmly securing

the inlay to the cover with the outer ends of said inlay folded inwardly about the marginal edge of the case member to which the inlay is applied. Furthermore, owing to the inlay bars having the edges thereof turned inwardly, the pressure exerted by the die will imbed the sides of the bar into the case covering to a greater or less degree and thereby further secure the inlay to the case.

10 That is, owing to the fact that the longitudinal edges of the bars are imbedded in the covering material as at 10', Figure 5, peculiarly adapts them to co-act with the adhesive in maintaining the bars against lateral displacement. Not only this, but inasmuch as the longitudinal edges 15 of the bars are slightly rounded and imbedded in the covering material, it is obvious that these edges will provide a smooth even feel and this has the further advantage of giving the impression that the thin metallic strips or bars 20 comprising the inlay are fully imbedded in the case with the outer surface thereof flush with the covering material.

25 This feature of the invention is clearly shown in Figure 5, although the drawing being made to such an enlarged scale greatly exaggerates the amount to which the inlay extends outwardly from the outer covering.

30 After the outer covering and inlay have thus been applied to the body and cover, the case is removed from the cover-applying apparatus and the inner covering or lining 6 is then manually applied in the conventional manner with the aid of a suitable adhesive so that the lining will not only cover the interior of the case body and cover but also the intumed edges of the outer covering and the intumed ends of the inlay bars so that the completed device will present a neat, finished and attractive appearance.

40 In Figures 6, 7 and 8 I have illustrated a modified form of inlay and outer covering. In this instance, the outer covering as 20 is composed of two separate contrasting pieces of material 20' and 20'' which may be of the same kind but of different color or they may be of different kinds, such for instance, as leather and a treated fabric formed in the manner previously described.

45 These covering pieces are arranged in juxtaposed relation with their adjacent edges extending diagonally across the case cover. These covering pieces may be, as shown, applied directly to the corresponding portions of the case member or the outer surface of the case may be completely covered with one of the cover members such as the fabric 20'' and the other cover piece 55 as 20' may be applied over a corresponding portion of the underlying fabric cover.

60 The inlay shown in these figures comprises a single bar 8 formed in the manner described above for the bars in the inlay shown in Figure 3. The bar 8 is arranged obliquely across the case cover in such a manner as to span the adjacent edges 21 of the covering materials so as to conceal said edges therebeneath, as illustrated in Figure 7. The bar 8 is of greater length than the underlying portion of the upper surface of the cover and has the ends thereof folded inwardly about the edges of the cover in the same manner in which the ends of the inlay shown in Figures 1 and 2 are folded and these intumed ends 70 of the bar 8 function to maintain the bar in fixed relation with the cover and are concealed by the inner covering or lining 6 in the manner previously described for the device shown in Figures 1 to 5 inclusive.

It will be noted that when the covering and inlay are constructed in the manner disclosed in Figures 6, 7 and 8 that the inlay not only serves as a decoration for the case but also functions as a retaining member for holding the adjacent edges of the two contrasting cover materials in position.

In Figures 9 to 12 inclusive, I have shown modified forms of case coverings together with further modifications of my novel decorative element or inlay. For instance, in Figure 9 the outer covering as 25 is composed of a single piece of material provided with contrasting colored portions. The inlay as shown more particularly in Figure 10 is provided with a longitudinally extending bar 26 and two angularly disposed bars 27 which extend obliquely across the longitudinal bar 26 in spaced relation to adjacent ends thereof. These angularly disposed bars 27 intersect each other near one end in a plane substantially midway between the ends of the longitudinal bar 26 and the adjacent ends of the angular bars 27 are tied together by a cross bar 28 while the other ends of the angular bars 27 and the corresponding ends of the longitudinal bar 26 are tied together by cross bars 29. Other angularly disposed bars 30 extend from the junction of the angular bars 27 outwardly in diverging planes thereto and connect with the longitudinal bar 26 intermediate the junction of the angular bars 27 with said longitudinal bar and the corresponding outer end of the longitudinal bar to form triangular sections 31.

The inlay as shown in Figure 10 is applied to the case cover in the manner shown in Figure 9 with the longitudinal bar 26 extending longitudinally of the cover in spaced parallel relation with the hinged side thereof while the junction of the angularly disposed bars 27 is arranged substantially midway between the ends of the case in spaced relation to the edge thereof opposite the hinge side.

The outer end portions of the longitudinal bar 26 and angularly disposed bars 27 are folded inwardly about the edge of the cover member in a manner shown and described for the structure shown in Figures 1 and 2 so that the cross tie members 28 and 29 will lie within the case and be concealed by the inner covering or lining thereof. It is thus seen that these tie bars function in the same manner as the tie bars 13 shown in Figure 3 for maintaining the end portions of the adjacent bars 26 and 27 in predetermined spaced relation during the application of the inlay to the case.

The major portion of the outer covering which is shown plain may be of any suitable color such as blue, while the portions of the cover defined by the triangular sections 31 are shaded as indicated by section line from a deep yellow or gold adjacent the longitudinal bar 27 to a red or pink at the opposite end thereof. Also the triangular portion defined by the outer ends of the angular bars 27 adjacent the junction thereof is colored as indicated by section lines green.

In the structure shown in Figures 11 and 12 the inlay is composed of a plurality of, in this instance three, longitudinally extending bars 35 which are arranged in slightly parallel spaced relation. A pair of angularly disposed bars 36 are arranged to extend obliquely across the longitudinal bars 35 intermediate the centers and ends thereof. As illustrated, the outer ends of the angular bars 36 and the corresponding ends of the longitudinal bars 35 are tied together by

cross bars 37 while the opposite ends of the angular bars 36 are tied together by a cross bar 38.

The cross bar 38, in this instance, has each end thereof extended beyond the corresponding angular bar 36 and is connected with the longitudinal bars 35 by a pair of angularly disposed bars 39 arranged in spaced parallel relation with the adjacent portion of the angular bar 36.

It will be noted that when this inlay is applied to the case, as illustrated in Figure 11, the cross bars 37 and 38 will lie within the case cover in spaced relation to the adjacent edge thereof similar to the manner in which the tie bars 13 are arranged and will maintain the corresponding longitudinal or angularly disposed bars in predetermined spaced relation during the application of the inlay to the case.

It will be noted by referring to Figure 11 that I have here again illustrated another decorative arrangement of the case cover which combines with the metallic inlay to produce novel artistic effects. For instance, I have shown certain portions as 40 and 41 of the case cover as outlined by the bars of the inlay member which contrast in appearance from the remaining portion of the case. These portions 40 and 41 may be formed by coloring the corresponding portions of the cover member to produce contrasting shades or the portions may be formed by embossing or the like to represent leather or the portions may be formed by securing portions of leather to the underlying portion of the outer covering to produce varied and artistic effects.

Although I have shown and particularly described the various features of this invention together with certain modifications or different arrangements thereof, I do not wish to be limited to the exact construction shown as various other changes may be readily made without departing from the spirit of the invention as set forth in the appended claims.

I claim:

1. A spectacle case or the like comprising in combination a case member and a decorative element for said case member including an elongated substantially flat element arranged across the outer surface of the case member, said elongated element being formed with an inwardly curved edge imbedded in the case member to form a substantially smooth even surface from the case member to the decorative element, and means for securing the element to said case member.

2. A spectacle case or the like comprising in combination a case member and a decorative element for said case member comprising a substantially flat bar arranged across the outer surface of the case member, said bar being formed with an inwardly curved edge imbedded in the case member to form a substantially smooth surface from the case member to the bar, and means for securing the decorative element to said case member.

3. A spectacle case or the like comprising in combination a case member and a decorative element for said case member comprising a substantially flat bar arranged across the outer surface of the case member and having the ends thereof folded inwardly about the edge of the case member for securing the bar to said member, the edges of said bar being curved inwardly toward the case to form a substantially smooth even surface from the case member to the bar.

4. A spectacle case comprising a sheet metal

cover member for the case, a covering of flexible material extending over the outer surface of the cover member, and a decorative bar arranged across the outer covering and having the ends thereof folded inwardly about the edge of the case member for securing the bar to said member, said bar being formed with inwardly curved edges imbedded in said outer covering.

5. A spectacle case or the like comprising in combination a case member having a covering of flexible material extending over the outer surface thereof, a decorative bar arranged across the covering with the ends folded inwardly about the edge of the case member for securing the bar to said member, and additional means for securing the bar to the covering.

6. In a spectacle case or the like comprising in combination a case member having a covering extending over the outer surface thereof, said covering comprising two pieces of flexible material arranged in juxtaposed relation with their adjacent edges extending across the outer surface of the case member, and a metallic bar inlay arranged over said adjacent edges of the covering, and means for securing the bar inlay in position.

7. A case for spectacles or the like comprising a case member having a covering including areas of contrasting surfaces, a metallic decorative bar arranged across said case member for joining said surfaces, the ends of the bar being folded inwardly about the edge of the case member for securing the bar to said member, and additional means for securing the bar and covering together.

8. In a case for spectacles or the like, a decorative element comprising a plurality of thin substantially flat metallic bars arranged in spaced relation, said bars being adapted to extend across the outer surface of the member of the case with the ends thereof folded inwardly about the edge of said member, and tie means connecting the adjacent ends of the bars for maintaining the corresponding end portions of said bars in fixed predetermined relation with each other.

9. A device as in claim 8 in which the bars have their longitudinal edges curved laterally whereby said edges will become more or less imbedded in the case member when the bars are applied thereto under pressure.

10. A device as in claim 8 in which the bars are formed slightly convex in cross section whereby the longitudinal edges thereof will become more or less imbedded in the case member when the bars are applied thereto under pressure.

11. In a device of the class described, the combination with a case for spectacles or the like comprising a body member and a cover member hinged together, a covering of flexible material extending over the outer surfaces of the body and cover members and folded inwardly over the edges of said members, and a lining element for said case adapted to extend over the inturned edge of the outer covering, of a thin substantially flat metallic decorative bar arranged across the outer covering of one of the case members and with the ends thereof folded inwardly about the edge of said member and extended beneath the case lining to be concealed thereby.

12. In a device of the class described, the combination with a case for spectacles or the like comprising a body member and a cover member hinged together, a covering of flexible material extending over the outer surfaces of the body and cover members and folded inwardly over the

edges of said members, and a lining element for said case adapted to extend over the inturned edge of the outer covering, of a decorative element comprising a plurality of thin substantially flat metallic elongated bars arranged with their ends in spaced relation, means comprising cross bars securing adjacent ends of the elongated bars in fixed predetermined relation, said elongated bar being arranged across the outer covering of one of the case members and having the ends thereof folded inwardly about the edge of said member with said cross bars positioned beneath the case lining to be concealed thereby.

13. A method of manufacturing a decorated case for spectacles or the like which comprises providing a decorative element from a thin substantially flat metallic bar or strip, applying adhesive to one side of the bar, positioning said bar on the outer surface of one of the case members and folding the ends of the bar inwardly about the edge of the case member, and then securing the element to the case by the application of heat and pressure.

14. A method of manufacturing a decorated case for spectacles or the like which comprises providing a decorative element from a thin substantially flat metallic bar or strip, applying adhesive to one side of the bar, positioning said bar on the outer surface of one of the case members and folding the ends of the bar inwardly about the edge of the case member, then securing the element to the case by the application of heat and pressure, and then applying a lining to the interior of the case and over said folded ends of the bar.

15. A method of manufacturing a decorated case for spectacles or the like which comprises forming a decorative element from a plurality of thin substantially flat metallic bars or strips, applying adhesive to one side of the bars, positioning said decorative element on the outer surface of one of the case members and folding the ends of certain of the bars or strips about the edge of said case member, and then securing the decorative element to the case by the application of heat and pressure.

16. A method of manufacturing a decorated case for spectacles or the like which comprises forming a decorative element from a plurality of thin substantially flat metallic bars or strips, applying adhesive to one side of the bars, positioning said decorative element on the outer surface of one of the case members and folding the ends of certain of the bars or strips about the edge of said case member, then securing the decorative element to the case by the application of heat and pressure, and then applying a lining to the interior of the case and over said folded ends of the bars.

17. A spectacle case comprising in combination a sheet metal case member having a covering of flexible material extending over the outer surface thereof, a thin metallic element located upon said covering, said metallic element being formed with an inwardly curved edge imbedded in said covering to form a substantially smooth even surface therewith, adhesive means on the under side of said metallic element for securing the same to said covering, and additional mechanical means integral with said metallic element and cooperating with said case member for holding said metallic element in position.

CARL R. JERRY.