

**(12) PATENT**  
**(19) AUSTRALIAN PATENT OFFICE**

**(11) Application No. AU 200240667 B2**  
**(10) Patent No. 766299**

(54) Title  
Routing service method in voice over internet protocol system

(51) 6 International Patent Classification(s)  
H04L 012/66

(21) Application No: 200240667 (22) Application Date: 2002.05.15

(30) Priority Data

(31) Number	(32) Date	(33) Country
01/29285	2001.05.26	KR

(43) Publication Date : 2002.11.28  
(43) Publication Journal Date : 2002.11.28  
(44) Accepted Journal Date : 2003.10.16

(71) Applicant(s)  
Samsung Electronics Co., Ltd.

(72) Inventor(s)  
Eung-Moon Yeom

(74) Agent/Attorney  
Griffith Hack,GPO Box 1285K,MELBOURNE VIC 3001

(56) Related Art  
"INTEGR.DIGI...AND INTERFACE" (TELC. TECH)GR-303-ILR DEC.'00  
US 6157636  
WO 01/06740

#### **ABSTRACT**

A routing service method in a public switched telephone network (PSTN) system uses a stand-alone gateway interworking with disparate central office lines. The stand-alone gateway checks whether a call service can be provided over the Internet with reference to an internal database having periodically updated call service state information in response to a call service request from a calling private branch exchange (PBX) connected to the stand-alone gateway via a central office line. If the call service cannot be provided over the Internet, the stand-alone gateway transmits a call service request, together with a public switched telephone network (PSTN) rerouting control request, to the calling PBX. The calling PBX transfers the call to a called party over the PSTN in response to the PSTN rerouting control request.

AUSTRALIA  
Patents Act 1990

**COMPLETE SPECIFICATION**  
**STANDARD PATENT**

**Applicant:**

SAMSUNG ELECTRONICS CO., LTD.

**Invention Title:**

ROUTING SERVICE METHOD IN VOICE OVER INTERNET  
PROTOCOL SYSTEM

The following statement is a full description of this  
invention, including the best method of performing it known to  
me/us:

**TITLE**  
**ROUTING SERVICE METHOD IN VOICE OVER INTERNET**  
**PROTOCOL SYSTEM**

5 **CLAIM OF PRIORITY**

This application makes reference to, incorporates the same herein, and claims all benefits accruing under 35 U.S.C. §119 from my application *ROUTING SERVICE METHOD IN VOICE OVER INTERNET PROTOCOL SYSTEM* filed with the Korean Industrial Property Office on 26 May 2001 and there duly assigned Serial No. 29285/2001.

10 **BACKGROUND OF THE INVENTION**

**Technical Field**

The present invention relates generally to a voice over Internet protocol (VoIP) system and, in particular, to a routing service method in a VoIP system using a stand-alone gateway.

15 **Related Art**

VoIP is a novel communication service that delivers voice information over the Internet rather than over the public switched telephone network (PSTN). A major advantage of VoIP telephony is that it avoids the tolls charged by ordinary telephone service, including domestic/international calls, because VoIP is implemented in a packet-based network. VoIP sends video information, as well as audio information, using International Telecommunications Union-Telecommunications standardization sector (ITU-T) H.323.

25 A VoIP system includes the Internet. The Internet is connected to gateways and personal computers (PCs). The gateways are connected to respective PSTNs that are in turn connected to telephones. The telephones and the PCs are endpoints that can communicate in voice (mandatory), with pictures (optional), and with data (optional) in one-to-one conversations or conferences. These terminals can carry out real-time bi-directional communications with the gateways or other

H:\jobz\k\keep\Spec\Samsung\40667-02.doc 13/08/03

terminals.

The gateways enable terminals (*e.g.*, the PCs) connected to the Internet, which is a packet-based network, or terminals (*e.g.*, the telephones) connected to the PSTNs or to the integrated services digital network (ISDN), to make real-time bi-directional communications. For example,  
5 the gateways send voice and fax data received from the PSTNs to the Internet after real-time compression and protocol conversion.

Such gateways are usually categorized into three types according to installation and usage: a built-in type that is inserted in the form of a card in a key telephone system (KTS) or a private  
10 branch exchange (PBX); a server type installed in a platform like window network terminal (NT); and a stand-alone type independent of other terminals. Stand-alone gateways are divided into trunk and ear and mouth (TANDEM) types and stand-alone types according to their functionalities. A stand-alone gateway with the TANDEM functionality supports interworking between disparate central office (CO) lines. The TANDEM stand-alone gateway is connected to a PBX and/or a KTS  
15 via an internal T1/E1 interface, a loop start trunk interface, and a subscriber line circuit (SLC) interface. A stand-alone gateway with the stand-alone functionality is connected directly to a plurality of telephones.

As to a routing service, when attempting a VoIP call in a VoIP system using stand-alone  
20 gateways upon origination of a VoIP call from a caller, the VoIP call is transferred to a local stand-alone gateway via a calling PBX. The local stand-alone gateway routes the VoIP call to a called party via a route which is chosen as the best one. The route runs from the caller to the called party through the calling PBX, the local stand-alone gateway, the Internet, a remote stand-alone gateway, and a called PBX.

25

If the local stand-alone gateway senses that the route is not available for the call service due to, for example, link-down of the remote stand-alone gateway, it chooses the second best route. The route runs from the caller to the called party through the calling PBX, the local stand-alone gateway, a PSTN central office (CO) line, a PSTN, a PSTN, and the called PBX. If the best route is not

H:\johal\kcep\Spec7\Samsung\40667-02.doc 13/08/03

available, the local stand-alone gateway takes a roundabout route through the PSTNs in order to route the call to the called party. In order to take the roundabout route via the CO line, the local stand-alone gateway and the remote stand-alone gateway should have CO line interfaces.

- 5 To offer such a roundabout route call service over a legacy network, the CO line should be prepared just in case. Preservation of the CO line for access to a legacy network, such as the PSTN, is a redundancy from the VoIP system's perspective. As a result, the line interfaces of the stand-alone VoIP system are or become less flexible.

10 **SUMMARY OF THE INVENTION**

According to one aspect of the present invention, there is provided a routing service method in a voice over internet protocol (VoIP) system using a stand-alone gateway interworking with disparate central office lines, comprising the steps of:

- 15 determining in the stand-alone gateway whether a call service can be provided over the Internet, with reference to an internal database having periodically updated call service state information, in response to a call service request from a calling private branch exchange (PBX) connected to the stand-alone gateway via a central office line;
- 20 transmitting the call service request, together with a public switched telephone network (PSTN) rerouting control request, to the calling PBX by means of the stand-alone gateway, when it is determined that the call service cannot be provided over the Internet; and
- 25 transferring the call to a called party over the PSTN by the calling PBX in response to the PSTN rerouting control request;
- wherein re-routing is performed by using a line used for an incoming call between the PSTN and the gateway.



According to a further aspect of the present invention, there is provided a routing service method in a voice over internet protocol (VoIP) system using a stand-alone gateway interworking with disparate central office lines, comprising the steps of:

H:\patent\keep\Spec\Samsung\40667-02.doc 13/08/03

determining in the stand-alone gateway whether a call service can be provided over the Internet, with reference to an internal database having periodically updated call service state information, in response to a call service request from a calling private branch exchange (PBX) connected to the stand-alone gateway via a central office line; and

5 transmitting the call service request, and requesting a public switched telephone network (PSTN) rerouting control to the calling PBX, between the calling PBX and the stand-alone gateway by means of the stand-alone gateway and through a central office line used for the call service request, when it is determined that the call service cannot be provided over the Internet

10 According to a further aspect of the present invention, there is provided a routing service method in a voice over internet protocol (VoIP) system using stand-alone gateways interworking with disparate central office lines, comprising the steps of:

providing a database which includes an access code table, an Internet protocol table, and a state table for remote gateways, and a PSTN rerouting setting field, to a local-stand alone gateway;

15 updating the state table by periodically testing links between a local stand-alone gateway and remote stand-alone gateways;

determining whether a call service over the Internet is available with reference to the state table by means of the local stand-alone gateway upon receipt of a call service request from a calling PBX connected to the local stand-alone gateway via a central office line;

20

inserting a PSTN central office line access code set in the PSTN rerouting setting field in the call service request, and transmitting the call service request with the PSTN central office line access code to the calling PBX, when the call service over the Internet is not available; and

requesting the call service to the PSTN using the PSTN central office line access code by means of the calling PBX.

25

25

According to a further aspect of the present invention, there is provided a voice over internet protocol (VoIP) system which provides a routing service, said system comprising:

a stand-alone gateway interworking with disparate central office lines;

determining means in the stand-alone gateway for determining whether a call service can be

provided over the Internet, with reference to an internal database having periodically updated call service state information, in response to a call service request from a calling private branch exchange (PBX) connected to the stand-alone gateway via a central office line;

transmitting means in the stand-alone gateway for transmitting the call service request, together with a public switched telephone network (PSTN) rerouting control request, to the calling PBX when it is determined that the call service cannot be provided over the Internet; and

transferring means for transmitting the call to a called party over the PSTN by the calling PBX in response to the PSTN rerouting control request.

10 According a further aspect of the present invention, there is provided a voice over internet protocol (VoIP) system which provides a routing service, said system comprising:

a stand-alone gateway interworking with disparate central office lines;

determining means in the stand-alone gateway for determining whether a call service can be provided over the Internet, with reference to an internal database having periodically updated call service state information, in response to a call service request from a calling private branch exchange (PBX) connected to the stand-alone gateway via a central office line; and

15

transmitting means for transmitting the call service request, and requesting a public switched telephone network (PSTN) rerouting control to the calling PBX, between the calling PBX and the stand-alone gateway by means of the stand-alone gateway and through a central office line used for the call service request when it is determined that the call service cannot be provided over the Internet.

20

According to a further aspect of the present invention, there is provided a voice over internet protocol (VoIP) system which provides a routing service, said system comprising:

25

stand-alone gateways interworking with disparate central office lines;

20

a database which includes an access code table, an Internet protocol table, and a state table for remote gateways, and a PSTN rerouting setting field, said state table being updated periodically by testing links between a local stand-alone gateway and remote stand-alone gateways;

determining means for determining whether a call service over the Internet is available with



reference to the state table by means of the local stand-alone gateway upon receipt of a call service request from a calling PBX connected to the local stand-alone gateway via a central office line; inserting means for inserting a PSTN central office line access code set in the PSTN rerouting setting field in the call service request;

- 5 transmitting means for transmitting the call service request with the PSTN central office line access code to the calling PBX, when the call service over the Internet is not available; and requesting means in the calling PBX for requesting the call service to the PSTN using the PSTN central office line access code.

10 **BRIEF DESCRIPTION OF THE DRAWINGS**

A more complete appreciation of the invention, and many of the attendant advantages thereof, will be readily apparent as the same becomes better understood by reference to the following detailed description when considered in conjunction with the accompanying drawings, in which like reference numerals indicate the same or similar components, and wherein:

- 15 FIG. 1 is a schematic view of a VoIP system;  
FIG. 2 illustrates routing in a VoIP system using stand-alone gateways;  
FIG. 3 illustrates routing in a VoIP system using stand-alone gateways according to an embodiment of the present invention;  
20 FIG. 4 is a block diagram of a stand-alone gateway according to the embodiment of the present invention;  
FIGS. 5A, 5B and 5C illustrate interface configurations between the stand-alone gateway and a PBX or a KTS according to the embodiment of the present invention;  
FIG. 6 is a flowchart illustrating a routing operation in the stand-alone gateway according to  
25 the embodiment of the present invention;  
FIG. 7 illustrates a remote gateway access code table database according to the embodiment of the present invention;  
FIG. 8 illustrates a remote gateway IP table database according to the embodiment of the present invention; and

FIG. 9 illustrates a remote gateway state table database according to the embodiment of the present invention.

### DETAILED DESCRIPTION OF THE PREFERRED EMBODIMENT

5

A preferred embodiment of the present invention will be described hereinbelow with reference to the accompanying drawings. In the following description, well-known functions or constructions are not described in detail since they would obscure the invention in unnecessary detail.

10

FIG. 1 is a schematic view of a VoIP system which uses the Internet as a backbone. Referring to FIG. 1, the VoIP system includes the Internet 8. The Internet 8 is connected to gateways 6 and 10 and to personal computers (PCs) 16 and 18. The gateways 6 and 10 are connected to PSTNs 4 and 12, respectively, which are in turn connected to telephones 2 and 14, respectively. The telephones 2 and 14 and the PCs 16 and 18 are endpoints that can communicate in voice (mandatory), with pictures (optional), and with data (optional) in one-to-one conversations or conferences. These terminals can carry out real-time bi-directional communications with the gateways 6 and 10 or other terminals. The gateways 6 and 10 enable terminals (*e.g.*, the PCs 16 and 18) connected to the Internet 8, which is a packet-based network, or terminals (*e.g.*, the telephones 2 and 14) connected to the PSTNs 4 and 12 or the integrated services digital network (ISDN), to make real-time bi-directional communications. For example, the gateways 6 and 10 send voice and fax data received from the PSTNs 4 and 12, respectively, to the Internet 8 after real-time compression and protocol conversion.



25

Gateways, such as the gateway 6 shown in FIG. 1, are usually categorized into three types according to installation and usage: a built-in type that is inserted in the form of a card in a key telephone system (KTS) or a private branch exchange (PBX); a server type installed in a platform like window network terminal (NT); and a stand-alone type independent of other terminals. Stand-alone gateways are divided again into trunk and ear and mouth (TANDEM) types and stand-alone types according to their functionalities. A stand-alone gateway with the TANDEM functionality

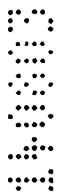

H:\patent\keep\Spec\Samsung\40667-02.doc 13/08/03

supports interworking between disparate central office (CO) lines. The TANDEM stand-alone gateway is connected to a PBX and/or a KTS via an internal T1/E1 interface, a loop start trunk interface, and a subscriber line circuit (SLC) interface. A stand-alone gateway with the stand-alone functionality is connected directly to a plurality of telephones.

5

A routing service during an attempt to make a VoIP call in a VoIP system using stand-alone gateways will now be described with reference to FIG. 2.

FIG. 2 illustrates the routing in a VoIP system using stand-alone gateways. Referring to FIG. 2, upon origination of a VoIP call from a caller 20, the VoIP call is transferred to a local stand-alone gateway 24 via a calling PBX 22. The local stand-alone gateway 24 routes the VoIP call to a called party 32 via a routing route R1 which is chosen as the best one. The route R1 runs from the caller 20 to the called party 32 through the calling PBX 22, the local stand-alone gateway 24, the Internet 26, a remote stand-alone gateway 28, and a called PBX 30.

15

If the local stand-alone gateway 24 senses that the route R1 is not available for the call service due to, for example, link-down of the remote stand-alone gateway 28, it chooses the second best route R2. The route R2 runs from the caller 20 to the called party 32 through the calling PBX 22, the local stand-alone gateway 24, a PSTN central office (CO) line 38, a PSTN 34, a PSTN 36, and the called PBX 30. If the best route R1 is not available, the local stand-alone gateway 24 takes a roundabout route through the PSTNs 34 and 36 so as to route the call to the called party 32. In order to take the roundabout route via the CO line 38, the local stand-alone gateway 24 and the remote stand-alone gateway 28 should have CO line interfaces.

To offer such a roundabout route call service over a legacy network (PSTN 34 in FIG. 2), the CO line 38 should be prepared just in case. Preservation of the CO line 38 for access to a legacy network, such as the PSTN 34, is a redundancy from the VoIP system's perspective. As a result, the line interfaces of the stand-alone VoIP system are or become less flexible.

FIG. 3 illustrates routing in a VoIP system using stand-alone gateways according to an embodiment of the present invention. Referring to FIG. 3, if call service over the Internet is not available, a VoIP call is routed via a roundabout route R3 involving a CO line 59, used for an incoming call between a calling PBX 42 and a local stand-alone gateway 44, and an existing CO line 58 between the calling PBX 42 and a PSTN 54, as compared to the routing method that uses the roundabout route R2 involving the CO line 38 between the PSTN 34 and the stand-alone gateway 24. In other words, the stand-alone gateway 44 uses an incoming trunk also as a roundabout-route outgoing trunk.

FIG. 4 is a block diagram of stand-alone gateways 44 and 48 according to the embodiment of the present invention. Referring to FIG. 4, each of the stand-alone gateways 44 and 48 comprises a system controller 60, a VoIP processor 62, a first memory 64 controlled by the system controller 60, and a second memory 66 controlled by the VoIP processor 62.

The system controller 60 provides overall control of the system. Specifically, the system controller 60 controls the operation of each board, senses and generates dual tone multi-frequency (DTMF) signals, supports a variety of dial tones, provides 256\_256 channel time slots and conference call service, and supports E1/T1 primary rate interface (PRI) digital line interfacing and R2 signaling. The first memory 64 includes a first flash memory for booting, a second flash memory for storing a program database used in the system, and a random access memory (RAM) for implementing system software. The VoIP processor 62 converts voice data for the PSTN 54 or 56 (FIG. 3) to data for the Internet 46, and supports the H.323 V3 protocol. The second memory 66 has a database for VoIP processing. The database includes an access code table, an IP table, and a state table for a remote gateway. A "rerouting insert digit" field for setting PSTN rerouting is also provided in the database.

An interface unit 80 has an SLC interface 68, a loop start trunk interface 70, a T1/E1/PRI interface 72, and an ear and mouth tie trunk (E&M) interface 74 in the form of cards. The SLC interface 68 provides an interface between a standard analog telephone and a gateway. The loop interface 70 offers a CO line interface for an exchange. The T1/E1/PRI interface 72 connects a high-

H:\j\l2\k\keep\Spec\1\Samsung\40667-02.doc 13/08/03

speed digital line T1 or E1, or an ISDN PRI line, to a gateway. The E&M interface 74 is used to link the gateway to a PBX or a KTS by means of a four-wire dedicated line.

FIGs. 5A, 5B and 5C illustrate interface configurations between a stand-alone gateway and a PBX or KTS according to the embodiment of the present invention. The stand-alone gateway 90 is linked to the PBX (or KTS) 92 by a T1/E1-T1/E1 interface in FIG. 5A, an E&M-E&M interface in FIG. 5B, and a foreign exchange office- foreign exchange station (FXO-FXS) interface in FIG. 5C. In the FXO-FXS interface of FIG. 5C, loop\_SLC interfacing is implemented separately for transmission (Tx) and reception (Rx).

10

In accordance with the embodiment of the present invention, the VoIP system includes the PBXs 42 and 50 (FIG. 3) that can access PSTNs 54 and 56, respectively, and the stand-alone gateways 44 and 48, respectively, for VoIP processing. The interface between the stand-alone gateways 44 and 48 and the PBXs 42 and 50 can be T1/E1-T1/E1, E&M-E&M, or FXO-FXS as shown in FIGs. 5A, 5B and 5C, respectively.

15

FIG. 6 is a flowchart illustrating a roundabout routing operation in the local stand-alone gateway 44 of FIG. 3. In the roundabout routing operation, the CO line 59 intended for an incoming call between the calling PBX 42 and the local stand-alone gateway 44 is also used for a roundabout outgoing call. That is, the local stand-alone gateway 44 uses the incoming trunk also as the roundabout-route outgoing trunk.

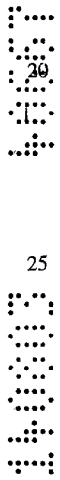

Referring to FIGs. 3 thru 6, upon origination of a VoIP call from a caller 40, the VoIP call is transferred to the local stand-alone gateway 44 through the calling PBX 42 and the CO line 59. In the local stand-alone gateway 44, the system controller 60 receives the VoIP call via the interface unit 80 configured as shown in FIGs. 5A, 5B or 5C, and provides an access code for VoIP call access (for example, '800') to the VoIP processor 62. Upon receipt of the access code '800', the VoIP processor 62 recognizes the incoming call from the calling PBX 42 in step 100 of FIG. 6. In step 102, the VoIP processor 62 obtains the IP address of the remote stand-alone gateway 48 from a remote gateway access code table in the second memory 66 using a destination phone number

25

contained in the incoming call that is obtained by accessing a VoIP port. That is, the local stand-alone gateway 44 receives the phone number entered by the caller 40 in the E.164 format, and searches the remote gateway access code table for the IP address of the remote stand-alone gateway 48 corresponding to the phone number of the E.164 format.

5

The IP address search will be described in more detail referring to FIGs. 7 thru 9. FIG. 7 illustrates an example of a remote gateway access code table database according to the embodiment of the present invention, and FIG. 8 illustrates an example of a remote gateway IP table database, while FIG. 9 illustrates a remote gateway state table database according to the embodiment of the present invention.

10

Referring to FIG. 7, the remote gateway access code table shown in FIG. 7 is a database from which an IP address is obtained using a phone number entered by a caller using an Internet phone. In FIG. 7, Access Code can be replaced with a D.D.D. number, Access Length represents D.D.D. length, and Trunk Access Code represents the trunk access code of a remote gateway. IP\_Table Index indicates an IP address group, which can be set by region (D.D.D.). Table 1 below shows an example of an access code table.

15

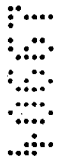

<Table 1>

index	Access code	Access length	Access code Del	Trunk Access code	IP index1	IP index2
1	031	4	Yes	8	0	1
...						

20

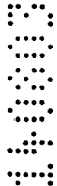

If a user enters a phone number "031-200-3000" in Seoul (Korea), a VoIP gateway obtains the IP address of an idle remote gateway from IP index 1, 2 in correspondence with "031". An actual

H:\jnlz\k\keep\Spec\Samsung\40667-02.doc 13/08/03

number that the VoIP gateway transmits to the remote gateway is "8-200-3000", which is produced by deleting "031" referring to Access code Del=Yes and, instead, inserting "8" of Trunk Access code. The remote gateway IP table shown in FIG. 8 lists the IP addresses of operating gateways for corresponding regions according to IP indexes of the access code table shown in FIG. 7.

5

Returning to FIG. 6, when the VoIP processor 62 searches for an IP address in the remote gateway access code table, it determines whether the VoIP call is serviceable over the Internet 46 in cooperation with the remote stand-alone gateway of the IP address in step 104. The determination is made with reference to the remote gateway IP table shown in FIG. 8 and the remote gateway state table shown in FIG. 9. The remote gateway state table has updated information about the channel states of remote gateways (busy, idle, and default) and the link states between the remote gateways and the local stand-alone gateway. That information is obtained by periodical link tests on the local stand-alone gateway and the remote gateways. Thus, the VoIP processor 62 can determine whether the VoIP call is serviceable with the remote gateway over the Internet 46 when the IP address is extracted from the incoming call from the calling PBX 42.

15

In step 106, the VoIP processor 62 determines whether the VoIP call service can be provided over the Internet 46. If the VoIP call is serviceable over the Internet 46, the VoIP call is processed in a normal way in step 108. In the normal VoIP call processing, the local stand-alone gateway 44 routes the VoIP call to the called party 52 via the best route R1 running from the local stand-alone gateway 44 to the called PBX 50 through the Internet 46 and the remote stand-alone gateway 48.



On the other hand, if the VoIP call service over the Internet 46 is impossible due to, for example, the link-down of the remote stand-alone gateway, channel busy, traffic congestion, packet loss, packet delay, etc., the VoIP processor 62 takes a roundabout route passing through PSTNs in steps 110 to 116.

25

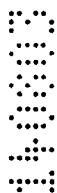

The VoIP processor 62 accesses the VoIP database of the second memory 66 in step 110, and checks whether a PSTN CO line access code value is set in the rerouting insert digit field in step 112.

H:\johkik\keep\Spec\Samsung\40667-02.doc 13/08/03

If it is set, the VoIP processor 62 generates a phone number for rerouting the VoIP call to the PSTN 54 by inserting a PSTN CO line access code ("9" in FIG. 3) before a destination phone number in step 114. In step 116, the VoIP processor 62 transfers a call corresponding to the phone number for rerouting to the PSTN 54 to the calling PBX 42 under the control of the system controller 60. At the same time, the local stand-alone gateway 44 controls the CO line 59 for an incoming call between the calling PBX 42 and the local stand-alone gateway 44 to be used for a roundabout outgoing call. That is, the local stand-alone gateway 44 uses the incoming trunk also as the roundabout outgoing trunk.

10 Meanwhile, the calling PBX 42 processes the call received via the CO line 59 as a new incoming call from the local stand-alone gateway 44. More specifically, the calling PBX 42 recognizes, from the PSTN CO line access code inserted before the phone number, that the call is destined for the PSTN 54, deletes the PSTN CO line access code (for example, "9"), and then transmits the destination phone number to the PSTN 54.

15

As described above, when taking a roundabout route for the VoIP call, the local stand-alone gateway 44 generates the PSTN access code for the calling PBX (or KTS) and inserts it before the destination phone number, so that the called PBX (or KTS) 42 can process the roundabout call without separate phone number processing for a TANDEM. A single PSTN access code can be fixed, for example, "9".



In the VoIP system of the present invention, if a VoIP call is not serviceable over the Internet 46, the VoIP call service is implemented via the second best routing route R3. The routing route R3 runs from the caller 40 to the called party 52 through the calling PBX 42, the local stand-alone gateway 44, the calling PBX 44, the PSTN 54, the PSTN 56, and the called PBX 50.

25

In accordance with the present invention, when it is necessary to take a roundabout route for a VoIP call service due to link-down, channel busy, packet loss, and packet delay between a local stand-alone gateway and a remote stand-alone gateway, the VoIP call can be routed to a called party

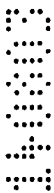

H:\j\zik\kleep\Spec\Samsung\40667-02.doc 13/08/03



via the roundabout route over the PSTN using an existing interface between a calling PBX and the local stand-alone gateway without the need for procuring a separate CO line interface for the PSTN.

Although a preferred embodiment of the present invention has been described, it will be  
5 understood by those skilled in the art that the present invention should not be limited to the described preferred embodiment. Rather, various changes and modifications can be made within the spirit and scope of the present invention, as defined by the following claims.

5

5

**THE CLAIMS DEFINING THE INVENTION ARE AS FOLLOWS:**

- 1 A routing service method in a voice over internet protocol (VoIP) system using a stand-alone gateway interworking with disparate central office lines, comprising the steps of:
- 5 determining in the stand-alone gateway whether a call service can be provided over the Internet, with reference to an internal database having periodically updated call service state information, in response to a call service request from a calling private branch exchange (PBX) connected to the stand-alone gateway via a central office line;
- 10 transmitting the call service request, together with a public switched telephone network (PSTN) rerouting control request, to the calling PBX by means of the stand-alone gateway, when it is determined that the call service cannot be provided over the Internet; and
- transferring the call to a called party over the PSTN by the calling PBX in response to the PSTN rerouting control request;
- 15 wherein re-routing is performed by using a line used for an incoming call between the PSTN and the gateway.
2. The routing service method of claim 1, wherein the transmitting step comprises sub-steps of:
- checking a re-routing insert digit when it is determined that the call service cannot be provided over the internet;
- 20 determining whether a re-routing digit bit is set;
- generating a PSTN re-routing phone number when it is determined that the re-routing digit bit is set; and
- transmitting the PSTN re-routing phone number to the calling PBX.
- 25 3. The routing service method of claim 1, further comprising providing a central office line interface between the stand-alone gateway and the calling PBX, said central office line interface being one of a T1/E1-T1/E1 interface, an ear and mouth tie trunk-ear and mouth tie trunk (E&M-E&M) interface, and a foreign exchange office- foreign exchange station (FXO-FXS) interface.

H:\pat\k\keep\Spec3\Samsung\40667-02.doc 130803

4. A routing service method in a voice over internet protocol (VoIP) system using a stand-alone gateway interworking with disparate central office lines, comprising the steps of:

determining in the stand-alone gateway whether a call service can be provided over the

5 Internet, with reference to an internal database having periodically updated call service state information, in response to a call service request from a calling private branch exchange (PBX) connected to the stand-alone gateway via a central office line; and

transmitting the call service request, and requesting a public switched telephone network (PSTN) rerouting control to the calling PBX, between the calling PBX and the stand-alone gateway  
10 by means of the stand-alone gateway and through a central office line used for the call service request, when it is determined that the call service cannot be provided over the Internet.

5. The routing service method of claim 4, wherein the transmitting step comprises sub-steps of:  
15 checking a re-routing insert digit when it is determined that the cell service cannot be provided over the internet;

determining whether a re-routing digit bit is set;

generating a PSTN re-routing phone number when it is determined that the re-routing digit  
20 bit is set; and

transmitting the PSTN re-routing phone number to the calling PBX.

20  
25

6. A routing service method in a voice over internet protocol (VoIP) system using stand-alone gateways interworking with disparate central office lines, comprising the steps of:

providing a database which includes an access code table, an Internet protocol table, and a state table for remote gateways, and a PSTN rerouting setting field, to a local-stand alone gateway;

25 updating the state table by periodically testing links between a local stand-alone gateway and remote stand-alone gateways;

determining whether a call service over the Internet is available with reference to the state table by means of the local stand-alone gateway upon receipt of a call service request from a calling

H:\jdzk\kz\spec\3\Samsung\40667-02.doc 13/08/03

PBX connected to the local stand-alone gateway via a central office line;

inserting a PSTN central office line access code set in the PSTN rerouting setting field in the call service request, and transmitting the call service request with the PSTN central office line access code to the calling PBX, when the call service over the Internet is not available; and

5 requesting the call service to the PSTN using the PSTN central office line access code by means of the calling PBX.

7. A voice over internet protocol (VoIP) system which provides a routing service, said system comprising:

10 a stand-alone gateway interworking with disparate central office lines;

determining means in the stand-alone gateway for determining whether a call service can be provided over the Internet, with reference to an internal database having periodically updated call service state information, in response to a call service request from a calling private branch exchange (PBX) connected to the stand-alone gateway via a central office line;

15 transmitting means in the stand-alone gateway for transmitting the call service request, together with a public switched telephone network (PSTN) rerouting control request, to the calling PBX when it is determined that the call service cannot be provided over the Internet; and

transferring means for transmitting the call to a called party over the PSTN by the calling PBX in response to the PSTN rerouting control request.

20 8. The system of claim 7, wherein said transmitting means performs the operations of:

checking a re-routing insert digit when it is determined that the call service cannot be provided over the internet;

determining whether a re-routing digit bit is set;

25 generating a PSTN re-routing phone number when it is determined that the re-routing bit is set; and

transmitting the PSTN re-routing phone number to the calling PBX.

9. The system of claim 7, further comprising a central office line interface between the stand-alone gateway and the calling PBX.

10. The system of claim 9, wherein the central office line interface comprises one of a T1/E1-  
5 T1/E1 interface, an ear and mouth tie trunk-ear and mouth tie trunk (E&M-E&M) interface, and a foreign exchange office- foreign exchange station (FXO-FXS) interface.

11. A voice over internet protocol (VoIP) system which provides a routing service, said system comprising:

10 a stand-alone gateway interworking with disparate central office lines;  
determining means in the stand-alone gateway for determining whether a call service can be provided over the Internet, with reference to an internal database having periodically updated call service state information, in response to a call service request from a calling private branch exchange (PBX) connected to the stand-alone gateway via a central office line; and

15 transmitting means for transmitting the call service request, and requesting a public switched telephone network (PSTN) rerouting control to the calling PBX, between the calling PBX and the stand-alone gateway by means of the stand-alone gateway and through a central office line used for the call service request when it is determined that the call service cannot be provided over the Internet.

20

12. The system of claim 11, wherein said transmitting means performs the operations of:  
checking a re-routing insert digit when it is determined that the call service cannot be provided over the internet;

25

determining whether a re-routing digit bit is set;  
generating a PSTN re-routing phone number when it is determined that the re-routing bit is set; and  
transmitting the PSTN re-routing phone number to the calling PBX.

30



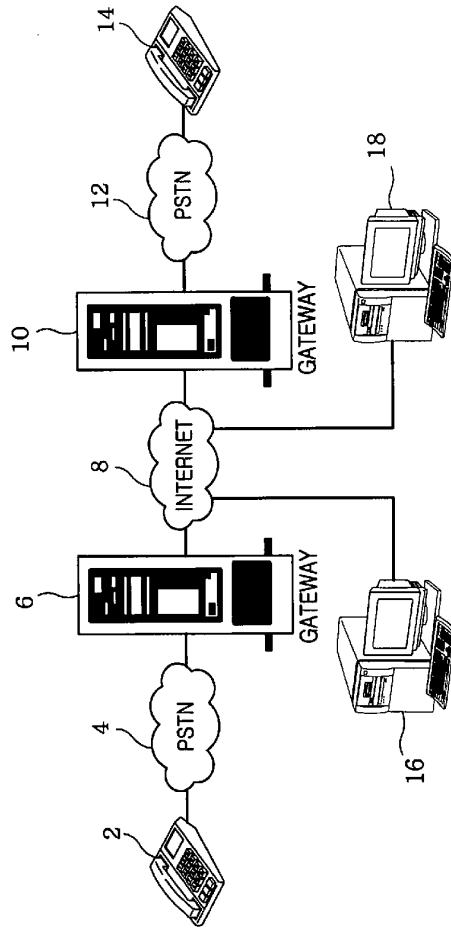

FIG.1

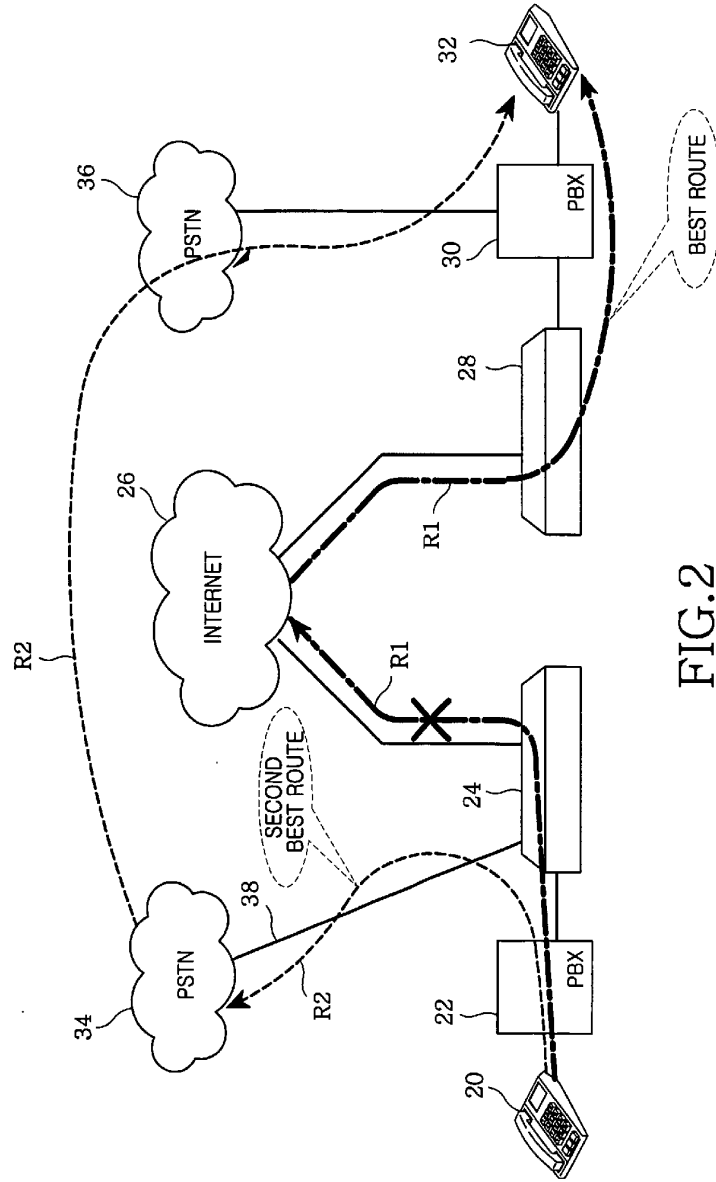

FIG.2





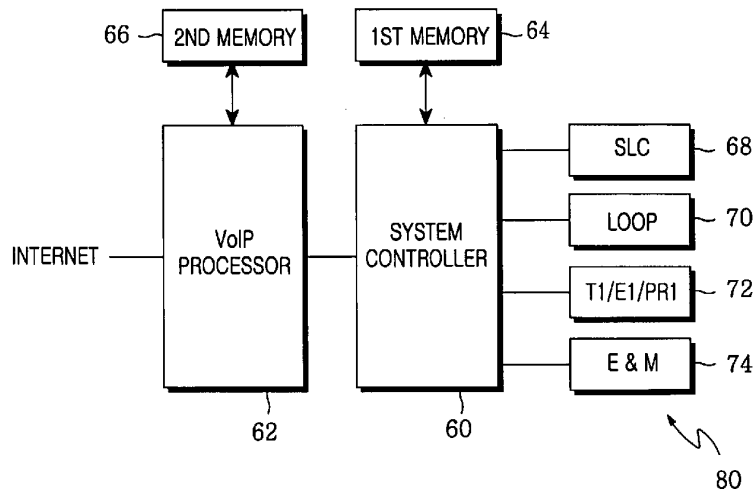
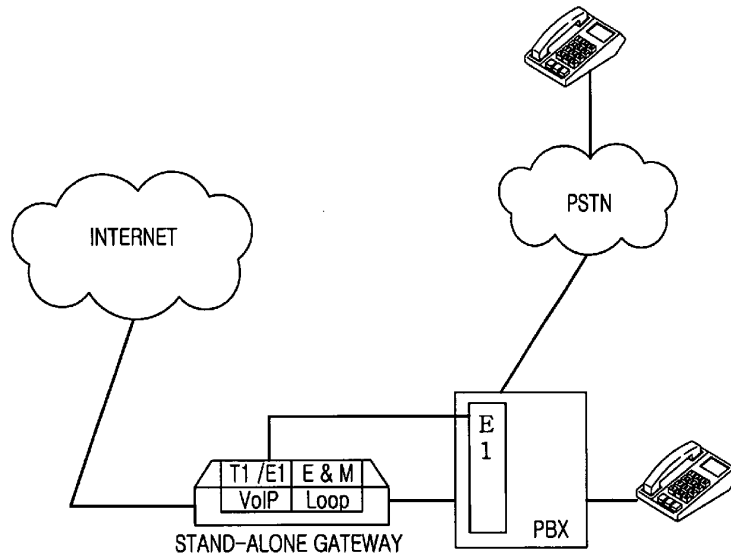

FIG. 4



<T1/E1 - T1/E1 INTERFACE>

FIG.5A

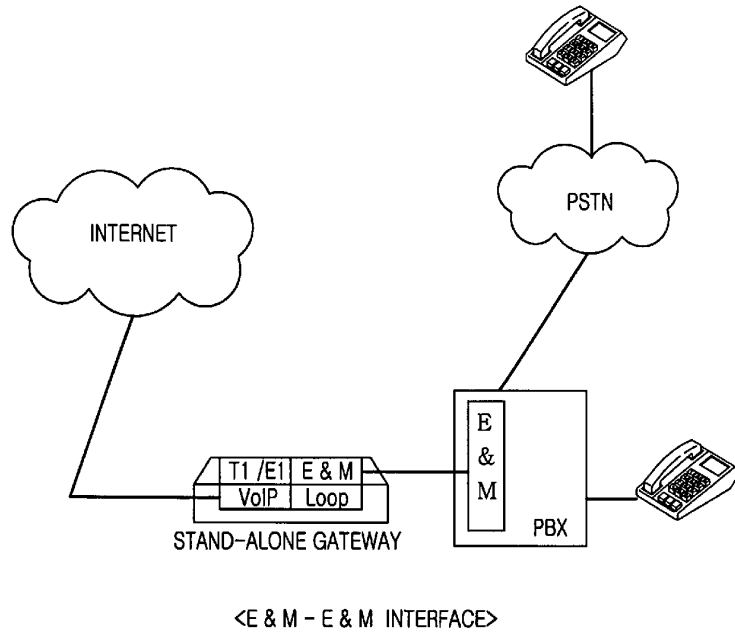
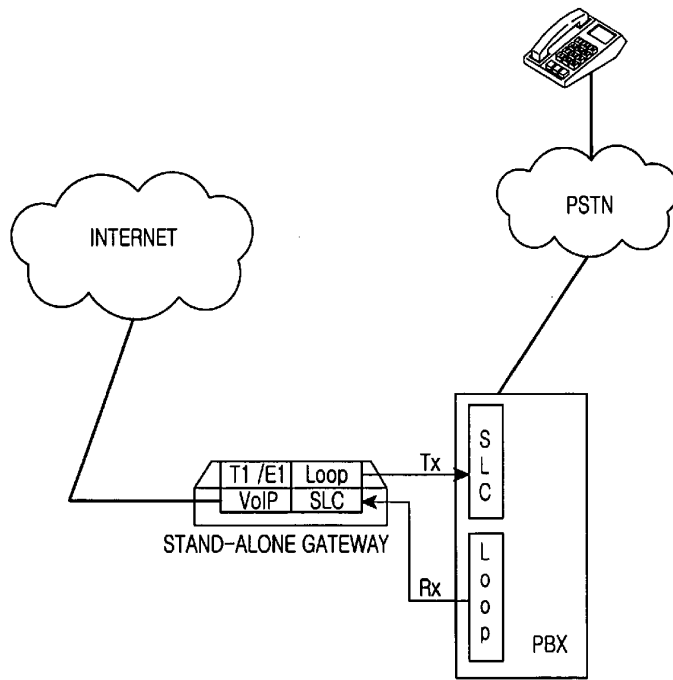

FIG.5B



<FXO - FXS INTERFACE>

FIG.5C

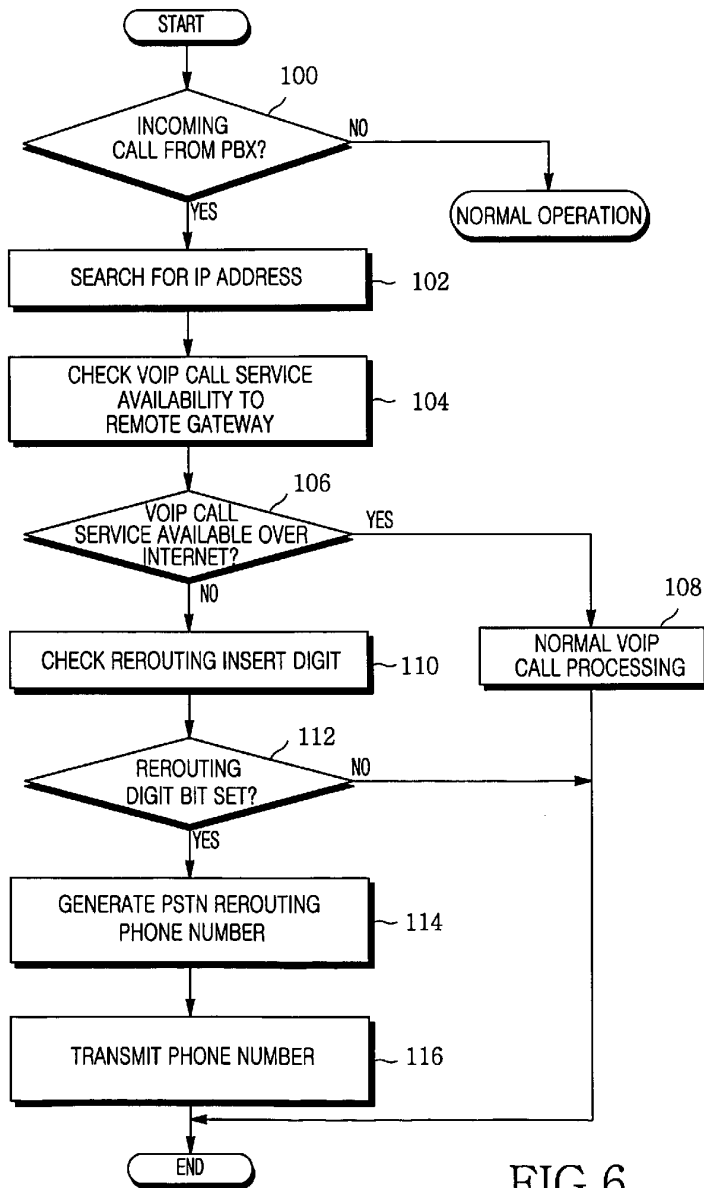

FIG.6

VoIP Access Code / VoIP DB Management / Data Base Management

VoIP General Option | VoIP DSP Option | Remote IP Status List  
 VoIP Access Code | VoIP Remote IP Table | VoIP ITM Configuration

INDEX	ACCESS CODE	ACCESS CODE LENGTH	ACCESS CODE DELETE	TRUNK CODE	ACCESS IP TABLE INDEX [0-30]	IP TABLE INDEX 2 [0-30]
32	[0000]	4	<input type="checkbox"/>	4	0	1
33			<input type="checkbox"/>			
34			<input type="checkbox"/>			
35			<input type="checkbox"/>			
36			<input type="checkbox"/>			
37			<input type="checkbox"/>			
38			<input type="checkbox"/>			
39			<input type="checkbox"/>			
40			<input type="checkbox"/>			
41			<input type="checkbox"/>			
42			<input type="checkbox"/>			
43			<input type="checkbox"/>			
44			<input type="checkbox"/>			
45			<input type="checkbox"/>			
46			<input type="checkbox"/>			
47			<input type="checkbox"/>			

INDEX [0-63] [0] [0]

UPDATE

FIG.7

VoIP Remote IP Table/VoIP DB Management/Data Base Management

VoIP General Option | VoIP DSP Option | Remote IP Status List  
 VoIP Access Code | VoIP Remote IP Table | VoIP ITM Configuration

IP TABLE[1]

INDEX	IP ACCESS	INDEX	IP ACCESS
0	192.10.200.14	16	0.0.0.0
1	192.10.200.15	17	0.0.0.0
2	192.10.200.16	18	0.0.0.0
3	0.0.0.0	19	0.0.0.0
4	0.0.0.0	20	0.0.0.0
5	0.0.0.0	21	0.0.0.0
6	0.0.0.0	22	0.0.0.0
7	0.0.0.0	23	0.0.0.0
8	0.0.0.0	24	0.0.0.0
9	0.0.0.0	25	0.0.0.0
10	0.0.0.0	26	0.0.0.0
11	0.0.0.0	27	0.0.0.0
12	0.0.0.0	28	0.0.0.0
13	0.0.0.0	29	0.0.0.0
14	0.0.0.0	30	0.0.0.0
15	0.0.0.0	31	0.0.0.0

IP TABLE INDEX [0-30] [0] [1/2]

FIG.8



Remote IP Status List/VoIP DB Management/Data Base Management									
VoIP Access Code		VoIP Remote IP Table		VoIP ITM Configuration					
VoIP General Option		VoIP DSP Option		Remote IP Status List					
NODE[1] SHELF[2] SLOT[3] IP TABLE INDEX[16]									
NO	IP ADDRESS	STATUS	NO	IP ADDRESS	STATUS				
0	0	LDLE	16	22	BUSY				
1	1	BUSY	17	23	BLOCK(LINK DOWN)				
2	2	BLOCK(LINK DOWN)	18	24	BLOCK(PACKET DELAY)				
3	3	BLOCK(PACKET DELAY)	19	25	BLOCK(PACKET LOSS)				
4	4	BLOCK(PACKET LOSS)	20	32	LDLE				
5	5	LDLE	21	33	BUSY				
6	6	BUSY	22	34	BLOCK(LINK DOWN)				
7	7	BLOCK(LINK DOWN)	23	35	BLOCK(PACKET DELAY)				
8	8	BLOCK(PACKET DELAY)	24	36	BLOCK(PACKET LOSS)				
9	9	BLOCK(PACKET LOSS)	25	37	LDLE				
10	16	LDLE	26	38	BUSY				
11	17	BUSY	27	39	BLOCK(LINK DOWN)				
12	18	BLOCK(LINK DOWN)	28	40	BLOCK(PACKET DELAY)				
13	19	BLOCK(PACKET DELAY)	29	41	BLOCK(PACKET LOSS)				
14	20	BLOCK(PACKET LOSS)	30	48	LDLE				
15	21	LDLE	31	49	BUSY				

NODE[0-7] SHELF[0-7] SLOT[0-15] IP TABLE INDEX [0-30] UPDATE

SUCCESSFULLY RECEIVED A RESPONSE

FIG.9