

(12) PATENT
(19) AUSTRALIAN PATENT OFFICE

(11) Application No. AU 199917275 B2
(10) Patent No. 739982

(54) Title
Apparatus and method for reusing satellite broadcast spectrum for terrestrially broadcast signals

(51)⁷ International Patent Classification(s)
H04H 001/00 H04B 007/185

(21) Application No: **199917275** (22) Application Date: **1998.12.15**

(87) WIPO No: **WO99/31832**

(30) Priority Data

(31) Number	(32) Date	(33) Country
08/991265	1997.12.16	US
09/001766	1997.12.31	US

(43) Publication Date : **1999.07.05**

(43) Publication Journal Date : **1999.09.02**

(44) Accepted Journal Date : **2001.10.25**

(71) Applicant(s)
Northpoint Technology, Ltd.

(72) Inventor(s)
Carmen Tawil; Saleem Tawil

(74) Agent/Attorney
PIZZEYS,PO Box 291,WODEN ACT 2606

(56) Related Art
US 5761605
AU 47506/97

17275/99



PCT

WORLD INTELLECTUAL PROPERTY ORGANIZATION
International Bureau

INTERNATIONAL APPLICATION PUBLISHED UNDER THE PATENT COOPERATION TREATY (PCT)

(51) International Patent Classification ⁶ : H04H 1/00, H04B 7/185	A1	(11) International Publication Number: WO 99/31832 (43) International Publication Date: 24 June 1999 (24.06.99)
--	----	---

<p>(21) International Application Number: PCT/US98/26655</p> <p>(22) International Filing Date: 15 December 1998 (15.12.98)</p> <p>(30) Priority Data: 08/991,265 16 December 1997 (16.12.97) US 09/001,766 31 December 1997 (31.12.97) US</p> <p>(71) Applicant: NORTHPOINT TECHNOLOGY, LTD. [US/US]; Suite 2530, 111 Congress Avenue, Austin, TX 78701 (US).</p> <p>(72) Inventors: TAWIL, Carmen; Suite 2530, 111 Congress Avenue, Austin, TX 78701 (US). TAWIL, Saleem; Suite 2530, 111 Congress Avenue, Austin, TX 78701 (US).</p> <p>(74) Agents: CULBERTSON, Russell, D. et al.; Shaffer & Culbertson, L.L.P., Building One, Suite 360, 1250 Capital of Texas Highway, S., Austin, TX 78746 (US).</p>	<p>(81) Designated States: AL, AM, AT, AU, AZ, BA, BB, BG, BR, BY, CA, CH, CN, CU, CZ, DE, DK, EE, ES, FI, GB, GE, GH, GM, HR, HU, ID, IL, IS, JP, KE, KG, KP, KR, KZ, LC, LK, LR, LS, LT, LU, LV, MD, MG, MK, MN, MW, MX, NO, NZ, PL, PT, RO, RU, SD, SE, SG, SI, SK, SL, TJ, TM, TR, TT, UA, UG, UZ, VN, YU, ZW, ARIPO patent (GH, GM, KE, LS, MW, SD, SZ, UG, ZW), Eurasian patent (AM, AZ, BY, KG, KZ, MD, RU, TJ, TM), European patent (AT, BE, CH, CY, DE, DK, ES, FI, FR, GB, GR, IE, IT, LU, MC, NL, PT, SE), OAPI patent (BF, BJ, CF, CG, CI, CM, GA, GN, GW, ML, MR, NE, SN, TD, TG).</p> <p>Published With international search report.</p> <div data-bbox="973 828 1364 1064" style="border: 1px solid black; padding: 5px; text-align: center;"> <p>IP AUSTRALIA - 5 JUL 1999 RECEIVED</p> </div>
--	--

(54) Title: APPARATUS AND METHOD FOR REUSING SATELLITE BROADCAST SPECTRUM FOR TERRESTRIALLY BROADCAST SIGNALS

(57) Abstract

A satellite receiving antenna (16) at a user location (14) receives satellite signals at a first frequency from a satellite (12). The satellite signals travel along a satellite signal route (42) within a look angle about the centerline (28) of the antenna (16). A terrestrial transmitter (20) transmits signals at the first frequency along a wireless transmission route (40) from the transmitter to the user location (14). The terrestrial transmitter (20) is located with respect to the user location (14) so that the wireless transmission route (40) is at a relatively large angle to the centerline (28) of the first antenna (16). The angle of the wireless transmission route (40) to the satellite antenna centerline (28) is large enough so that the terrestrial signals present at the location (14) result in terrestrial input signals from the antenna (16) which are less than an interference level with respect to satellite input signals produced by the antenna. Thus, the terrestrial signals do not interfere with the satellite signals even though they are transmitted at a common frequency.

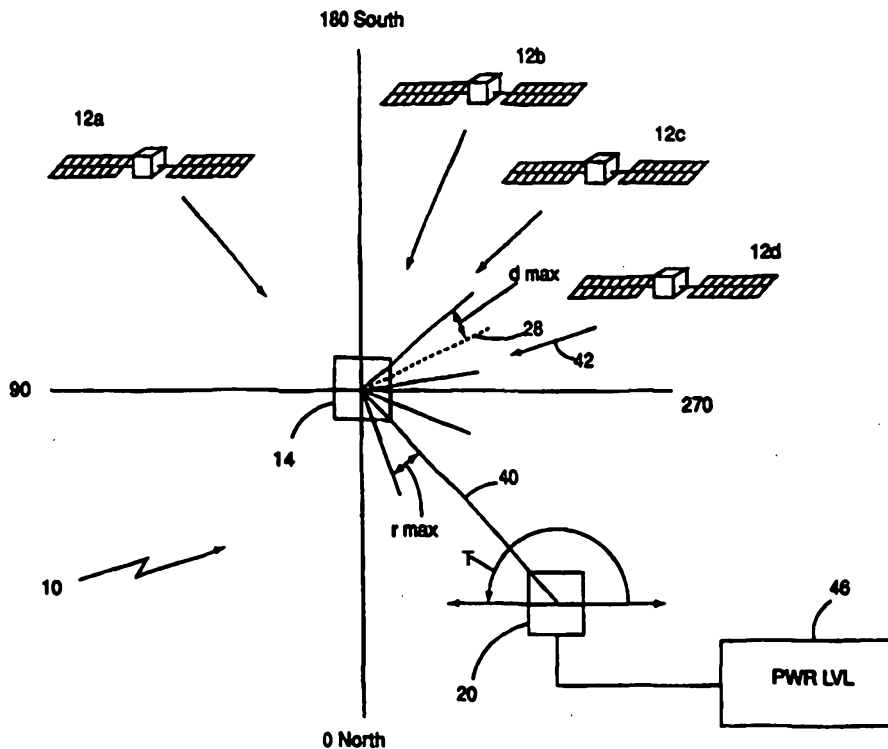

**APPARATUS AND METHOD FOR REUSING SATELLITE BROADCAST
SPECTRUM FOR TERRESTRIALLY BROADCAST SIGNALS**

BACKGROUND OF THE INVENTION

5

This invention relates to apparatus and methods for broadcasting and receiving data, including digital television signals, voice signals, and other data. More particularly, this invention relates to an apparatus and method for providing terrestrial transmissions simultaneously along with direct broadcast satellite transmissions on a common frequency.

10

Currently, television signals may be received from a satellite in geosynchronous orbit about the earth. The television signals are transmitted from a terrestrial transmitter to the satellite, perhaps communicated between different satellites, and then retransmitted from a satellite so that the signals can be received by terrestrial receivers within a certain geographic receiving area within a line of sight of the satellite. In addition to television signals, other types of data may also be transmitted to consumers through satellites in either

15

geosynchronous or non-geosynchronous orbit.

20

Direct broadcast satellite service (DBS) refers to satellite transmission of television signals and other data directly for use by individual households or subscribers having the proper signal receiving equipment. The U.S. Federal Communications Commission has dedicated the electromagnetic spectrum from 12.2 gigahertz to 12.7 gigahertz for DBS broadcasting. Numerous signal carriers are located within the DBS spectrum, each carrier carrying several individual television channels. Depending upon the compression technology applied to these signals, literally hundreds of separate channels may be available through DBS. A great benefit of the DBS system as opposed to prior satellite systems is that

25

only a small dish-type antenna is required to receive the DBS signals and the alignment of the receiving dish is not as critical as earlier satellite broadcast systems. Also, the DBS system will provide high quality reception at any point in the geographic receiving area of a satellite without the expense of land transmission lines such as those required for cable television.

Current regulations require that DBS satellites be separated from each other by at least nine (9) degrees in a geosynchronous arc. The receiving antenna for DBS signals must, therefore, be limited to receiving signals in a directional range measuring plus or minus nine (9) degrees from a centerline of the antenna. Receiving signals in a range wider than the satellite spacing would cause interference by signals transmitted by different satellites on the same frequency. The limited directional reception range of the DBS receiving antenna is the result of the gain provided by the antenna being asymmetrical about the antenna structure. DBS signals reaching the DBS receiving antenna at angles outside of the directional range of the antenna receive insufficient gain to interfere with the desired DBS signals received within the antenna directional range.

U.S. Patent No. 5,483,663 is directed to a system having a receiver arrangement in which DBS and terrestrial signals are received within similar frequency bands. The system shown in the 5,483,663 Patent may be implemented with a multiple antenna arrangement, or with a single, moveable antenna. In the multiple antenna arrangement, two separate antennas direct the received signals to a common propagation path for processing as if they were received by a single antenna and transmitted from a single location. In the single antenna arrangement, the antenna is movable between a position to receive DBS signals and another position to receive terrestrial signals.

The advantage of the system shown in U.S. Patent No. 5,483,663 is that local originating signals, whether carrying data for television or other data, may be received simultaneously with DBS signals, and processed with the same or similar equipment as that used to process the DBS signals. The local originating signals may carry local television programming which may be received along with the national or regional DBS television programming.

SUMMARY OF THE INVENTION

The invention includes an apparatus and method for transmitting terrestrial signals simultaneously with satellite signals transmitted at a common frequency.



5 The invention includes transmitting terrestrial signals in a manner which ensures that they do not interfere with satellite signals transmitted at the same frequency. Embodiments of the invention may take advantage of receiving antennae having a limited directional reception range or look angle and may include transmitting the terrestrial signals in a different range of directions than those in which the satellite signals are transmitted. The power level at which the terrestrial signals are transmitted and the directional nature of the satellite receiving antennae ensure that the satellite transmitted signals can be
10 discriminated from the terrestrially transmitted signals. Although the terrestrial signal transmission power is limited to a non-interfering transmission power level, the terrestrial transmission is still strong enough to produce a usable signal at a distant location.

15 Several different signals will be discussed in this disclosure. The term "satellite signals" refers to signals transmitted directly from a satellite, whereas the term "terrestrial signals" refers to signals transmitted directly from a terrestrial transmitter. "Satellite input signals" refers to signals resulting from satellite signals which have been picked up by an antenna and subjected to gain provided by the antenna. Finally, "terrestrial input signals" refers to signals resulting from
20 terrestrial signals which have been picked up by an antenna and subjected to gain provided by the antenna.

25 The invention is employed in the situation in which satellite signals are transmitted at a satellite transmission frequency to a terrestrial location. The satellite signals travel along a satellite signal route from the satellite to the terrestrial location and to a satellite receiving antenna at the location for receiving the satellite signals. In some embodiments of the invention, the satellite receiving antenna is omni-directional, that is, provides generally the same gain regardless of the direction from which the signals reach the antenna. In other forms of the invention, the satellite receiving antenna has a directional reception characteristic in which the gain provided by the antenna reaches a peak along an antenna centerline and generally decreases as the angle from the centerline increases.

30 The omni-directional satellite receiving antenna need not be oriented in a particular direction to receive signals from a satellite. However, in order to receive satellite signals with the directional satellite receiving antenna, the antenna must be aligned in a satellite reception position. In this satellite reception position, the
35 satellite signal route lies close



enough to the antenna centerline that the signals receive sufficient gain from the antenna structure to produce satellite input signals which are at least at a usable input signal level. This minimum usable input signal level represents the minimum input signal level at which the receiving or signal processing equipment can extract the desired data.

5 According to the invention, the terrestrial signals are transmitted at the same frequency as the satellite signals. The terrestrial signals are transmitted along a wireless route from the terrestrial transmitter to a user location which may have a satellite receiving antenna. The invention avoids interference between the terrestrial and satellite signals by ensuring that the power level of the terrestrial input signals at the satellite receiving antenna is below an interference level with respect to the satellite input signals at the satellite receiving antenna. The interference level is an input signal power level which is so close in power to the satellite input signal power level that the satellite input signals cannot be discriminated or distinguished. Terrestrial input signals below the interference level do not prevent the receiving or signal processing equipment associated with the satellite receiving antenna from distinguishing and extracting data from the satellite input signals. Also according to the invention, although the terrestrial signals are transmitted so that they do not interfere with the satellite signals, the terrestrial signals present at the user location must be strong enough so that they may be received by an appropriately aligned terrestrial receiving antenna at the location and distinguished from satellite input signals at the terrestrial receiving antenna. That is, the terrestrial signals present at the location must be at least at a minimum usable terrestrial signal level.

15 Where the satellite receiving antenna is omni-directional, both the satellite signals and the terrestrial signals picked up by the antenna receive substantially the same gain. Thus for omni-directional satellite receiving antennae, the terrestrial transmission power level must be controlled so that the terrestrial signals present at the user location have a sufficiently lower power level than the satellite signals present at the user location.

25 Where the satellite receiving antenna at the user location is a directional antenna, the invention may take advantage of the directional characteristic of the antenna and may transmit terrestrial signals at a high enough power level while still producing a terrestrial input signal at the satellite receiving antenna which is below the interference level. In the case of the directional satellite receiving antenna, the antenna is oriented in the satellite

30

reception position at the user location. The terrestrial transmitter is located with respect to the user location such that the wireless transmission route from the terrestrial transmitter to the user location is at a relatively large angle from the satellite receiving antenna centerline. At this relatively large angle, the terrestrial signals receive much less gain than the satellite signals. Thus, the terrestrial signal power level at the user location may be the same as or even higher than the satellite signal level and, due to the different gain applied to the signals by the antenna structure, still result in a terrestrial input signal having a power level below the interference level with respect to the satellite input signal level.

In some applications of the invention, depending upon the direction at which a directional satellite receiving antenna must be directed to receive satellite signals, the terrestrial transmissions may be limited to a certain azimuth range. This terrestrial transmission azimuth range is limited so that it does not include any directions that are within the satellite reception look angle of a directional satellite receiving antenna aligned to receive signals from a particular satellite. In order to cover a large geographic service area for terrestrial signal reception while maintaining the terrestrial transmission power at a non-interfering level, a plurality of terrestrial transmitters may be spaced apart over the area. In this case the effective transmission areas of the different transmitters combine to ensure the terrestrial signals may be received clearly at each location within the desired geographic service area.

The satellite transmissions and terrestrial transmissions may contain or carry any type of data including television, internet communications, voice, video, or any other type of data. Although the invention is not limited to any particular transmission frequencies, the invention is particularly well adapted for transmission frequencies above one thousand (1000) megahertz. Also, although the invention is not limited for use with a particular transmission modulation technique, modulation techniques such as phase modulation and spectrum spreading (frequency hopping) are currently preferred.

These and other objects, advantages, and features of the invention will be apparent from the following description of the preferred embodiments, considered along with the accompanying drawings.

BRIEF DESCRIPTION OF THE DRAWINGS

FIGURE 1 is a schematic representation showing the positions of a plurality of satellites in relation to a single terrestrial transmitter and a receiver or user location.

FIGURE 2 is a somewhat schematic representation of a receiving antenna structure for receiving satellite and terrestrial transmitted signals at a common frequency.

FIGURE 3 is a schematic representation of the spacing for a number of terrestrial transmitters required to allow reception over a large geographic area.

FIGURE 4 is a schematic representation of a terrestrial transmitter and terrestrial transmission power control arrangement embodying the principles of the invention.

DESCRIPTION OF THE PREFERRED EMBODIMENTS

An apparatus according to the invention for providing terrestrially transmitted signals simultaneously on the same frequency used to transmit satellite signals is illustrated in FIGURE 1. As shown in FIGURE 1, there may be one or more satellites in orbit about the earth. FIGURE 1 shows four satellites 12a, 12b, 12c, and 12d spaced apart at four separate directions from a user location 14. Satellite receiving antenna 16 and terrestrial receiving antenna 18, which will be discussed in detail with reference to FIGURE 2, may be located at the user location 14.

Each of these satellites 12a-d is positioned in geosynchronous orbit about the center of the earth, and is positioned at a certain longitude and latitude above the earth's surface. In geosynchronous orbit, each satellite remains at a fixed location with respect to the earth's surface, and thus, with respect to the user location 14. As is known by those skilled in the art, a directional receiving antenna may be directed at a certain elevation and direction or azimuth toward a desired satellite location for receiving signals from the particular satellite. Of course the satellite signals may be transmitted from satellites which are not in geosynchronous orbit. In this non-geosynchronous orbit case, the directional satellite receiving antenna can receive satellite signals only as the particular satellite passes through the directional reception range or look angle of the satellite receiving antenna, or the antenna must be moved to track the satellite.

Currently, all direct broadcast satellites within the line of sight of North America are positioned at longitudes and latitudes requiring a directional receiving antenna to face in a

southerly direction from North America to receive signals. Although FIGURE 1 shows four satellites 12a-d for purposes of describing the invention, more or fewer satellites may be spaced apart within a line of sight of a certain geographical area. Regardless of the number of satellites, the directional satellite receiving antenna must be directed at a particular azimuth and elevation to receive signals from a particular satellite. The term "azimuth" refers to the direction with respect to a reference direction such as due north, commonly zero degrees. "Elevation" refers to the angle of the antenna centerline above horizontal.

In contrast to directional receiving antennae, omni-directional antennae need not be oriented in any particular direction in order to receive signals. Thus an omni-directional antenna at the user location 14 would receive signals equally well from each of the satellites 12a-d.

DBS satellites all transmit different signals in the same frequency band. The U.S. Federal Communications Commission has set aside the electromagnetic spectrum from 12.2 gigahertz to 12.7 gigahertz for DBS broadcasting. In order to ensure no interference from signals between two adjacent satellites transmitting at the same frequency, two conditions must be met. First, the satellite receiving antenna must be a directional antenna and limited to receive signals at the DBS signal strength only within a certain reception range about the centerline of the antenna. Secondly, the satellites must be spaced apart so that a receiving antenna may be positioned with only a single satellite transmitting in the directional reception range or look angle of the antenna.

According to current regulations, individual DBS satellites must be separated at least nine (9) degrees in the geosynchronous arc. Thus, each DBS receiving antenna must have a directional reception range, look angle, or aperture of plus or minus nine (9) degrees or less as measured from a centerline of the antenna. Although current regulations require a spacing of no less than nine (9) degrees separation, the invention is not limited to use in situations in which the satellites have this degree of separation or in which the satellites operate in the current DBS frequencies.

FIGURE 1 also shows a terrestrial transmitter 20 capable of transmitting in one or more frequencies identical to a frequency transmitted by one of the DBS satellites. The terrestrial transmitter 20 transmits directionally within a certain transmission range or azimuth range T. The transmission range T shown in FIGURE 1 is 180 degrees, although

the range may be more or less than this number. In some situations, the transmission range may not be limited but may encompass the entire 360 degrees around the transmitter location.

5 A combined receiving antenna structure 22 which may be at the user location 14 in FIGURE 1 is illustrated in FIGURE 2. The satellite receiving antenna 16 is designed to receive direct broadcast satellite signals and preferably includes a collecting dish 24 and a feed-horn assembly 26 for receiving the signals reflected and concentrated by the dish. Those skilled in the art will readily appreciate that the feed-horn assembly 26 includes a probe and low noise block converter, which are not shown in FIGURE 2, for picking up
10 signals directed to the antenna. The received signals, which are defined herein as "input signals," are directed from the antenna to receiving or signal processing equipment, also not shown, for extracting information or data. This signal processing equipment is well known in the art and does not form a part of this invention. Also, those skilled in the art will appreciate that numerous types of assemblies may be used alternatively to the feed-horn
15 assembly 26 for collecting signals reflected by the dish 24. Furthermore, many other types of antennae may be used for receiving the satellite signals.

The satellite receiving antenna 16 is a directional antenna and thus has the characteristic that the signal gain produced by the antenna is highly dependent upon the direction at which the signals reach the antenna. The antenna 16 produces a maximum gain
20 for signals traveling to the structure along an antenna centerline 28. For signals traveling to the antenna structure 16 at an angle to the centerline 28, the antenna provides less gain. For the dish-type antenna 16 shown in FIGURE 2, the antenna gain decreases as the angle to the centerline 28 increases up to a certain angle on either side of the centerline. At angles outside of this certain angle, the gain may remain fairly constant. It will be understood that
25 the angle from the centerline 28 may be in the horizontal direction, vertical direction, or both.

As the antenna gain decreases with the increased angle from the centerline 28, an angle is reached at which the antenna gain is insufficient to develop a usable satellite input signal from the antenna 16 for a particular satellite transmission. The maximum reception
30 angle at which the antenna 16 will develop a usable signal is shown as d_{max} in FIGURE 1. The cone-shaped area defined by the angle d_{max} about the centerline 28 is commonly

referred to as the "look angle" or aperture of the antenna. Satellite signals at the designated power level propagating to the antenna 16 at an angle greater than d_{max} to the antenna centerline 28 result in input signals from the antenna less than the minimum usable input signal level. Signals below the minimum usable input signal level cannot be distinguished from background or noise produced by the antenna, and the signal processing equipment which receives the input signals cannot extract data from signals at these low signal levels. The minimum usable input signal level is determined by many factors including the bandwidth of the transmissions, the antenna structure, and the signal processing equipment which receives the signals developed by the antenna structure.

Referring to FIGURES 1 and 2, the satellite receiving antenna 16 which may be at location 14 is in a satellite reception position and is directed to receive signals from one of the satellites, satellite 12d for example. The azimuth and elevation at which the first antenna 16 must be directed for optimally receiving signals from satellite 12d may be, for example, 247.3 degrees and 25.7 degrees, respectively.

In the orientation shown in FIGURE 1, the satellite receiving antenna 16 at location 14 cannot receive signals from the terrestrial transmitter 20 in the presence of satellite signals at the same frequency. Two factors combine to prevent interference between the satellite and terrestrial signals. First, signals transmitted from the terrestrial transmitter 20 travel along a wireless transmission route 40 to the location 14 which lies outside of the look angle of the satellite receiving antenna 16. Thus, the terrestrial signals receive relatively low gain from the satellite receiving antenna 16 as compared to the satellite signals traveling along a satellite signal route 42 within the look angle of the antenna. Second, the terrestrial transmission power level is controlled according to the invention such that terrestrial signals at the location 14, with the low gain provided by the antenna 16 for signals traveling along wireless transmission route 40, result in terrestrial input signals from the antenna 16 which are below the interference level with respect to the satellite input signals from the antenna. Thus, even though the terrestrial signals may actually be picked up by the antenna 16 and produce terrestrial input signals from the antenna, the satellite input signals are in comparison strong enough for the signal processing equipment associated with the antenna to discriminate between the satellite and terrestrial input signals. The interference level will depend on several factors including primarily the signal processing equipment and, with

present technology, may be in the range of 3dB to 5dB below the level of the satellite input signals.

Although the direction of the terrestrial transmissions along wireless route 40 and terrestrial signal power level combine to prevent the terrestrial signals from interfering with the satellite signals at the same frequency, the power level of the terrestrial transmissions is still sufficient to produce a usable signal at the location 14. In order to receive terrestrial signals at the location, a terrestrial receiving antenna such as the antenna 18 shown in FIGURE 2 is required. The terrestrial receiving antenna 18 has a directional gain characteristic similar to the satellite receiving antenna 16 to ensure that the terrestrial signals produce an input which may be discriminated from the input produced by the satellite signals at the terrestrial antenna. For example, the terrestrial receiving antenna 18 at location 14 could have its centerline 30 aligned directly with the wireless transmission route 40 from the terrestrial transmitter 20. The directional reception range or look angle from the centerline of the antenna 18 is shown as r_{max} in FIGURE 1. At this orientation, the satellite signals are well outside the look angle of the terrestrial receiving antenna 18 and receive much lower gain as compared to the terrestrial signals. The terrestrial signals at that location 14 are strong enough that, with the help of the gain provided by the terrestrial receiving antenna 18, they result in terrestrial input signals that may be discriminated from any input signals at the terrestrial receiving antenna resulting from the satellite signals. With present technology the terrestrial input signals from the terrestrial receiving antenna 18 may be 3dB to 5dB or more above the power level of the satellite input signals from the terrestrial receiving antenna in order for the terrestrial input signals to be discriminated. Thus, the terrestrial transmission apparatus and method according to the invention allows satellite and terrestrial signals carrying entirely different information or data to be received and used simultaneously at user location 14.

The ability to transmit terrestrial signals at the same frequency as satellite signals without interference between the signals presents an opportunity for terrestrial reuse of spectrum previously reserved exclusively for satellite transmissions. Furthermore, since the terrestrial transmitter according to the invention has a limited effective transmission range, the spectrum reused for the terrestrial transmissions may also be reused for terrestrial transmissions in many different geographic areas.

It will be understood that the terrestrial receiving antenna 18 at the location 14 or any other user location, is not an element of the present invention. The terrestrial receiving antenna 18 is disclosed and discussed herein only for the purpose of emphasizing the utility of the terrestrial transmitting apparatus and method according to the invention. The satellite receiving antenna 16 is also not an element of the invention. Rather, the satellite receiving antenna 16 is discussed herein for the purpose of describing the manner and direction in which terrestrial signals must be transmitted according to the invention. In any case, the satellite and terrestrial receiving antennae which may be at any user location 14 need not be combined into a single structure. The combined structure 22 shown in FIGURE 2 is shown for convenience in describing the terrestrial transmission invention disclosed herein.

In the case of an omni-directional satellite receiving antenna, the antenna has no centerline such as centerline 28 shown in FIGURES 1 and 2, and no look angle or directional reception range. Rather, the gain provided by the antenna is substantially independent of the direction from which the signals reach the antenna. In that case, the method of the invention includes transmitting terrestrial signals at the first frequency similarly to the case described above in which the satellite receiving antenna is a directional antenna. However, the direction at which the terrestrial signals are transmitted cannot be relied upon to produce terrestrial input signals below the interference level with respect to the satellite input signals received at the omni-directional satellite receiving antenna. Rather, for the omni-directional satellite receiving antenna, the terrestrial transmission power level is controlled so that the terrestrial signals present at the user location are below the interference level with respect to the satellite signals at the user location. Since the omni-directional antenna provides the same gain to both the terrestrial and satellite signals, this signal level present at the satellite receiving antenna location ensures that the terrestrial input signals are below the interference level with respect to the satellite input signals.

Referring to FIGURE 3, a plurality of terrestrial transmitters 32 may be required to provide terrestrial signals strong enough to be received over a large area, but low enough to prevent interference with satellite signals at the same frequency. Each transmitter 32 in FIGURE 3 transmits directionally in an azimuth range A of approximately 180 degrees and out to an effective reception range R. Thus, each transmitter 32 transmits to an effective transmission area 43. With this transmitter spacing and transmission range, the signals from

the terrestrial transmitters 32 may be received from any location within the geographic service area comprising the combined effective transmission areas of the several terrestrial transmitters. Although the directional range of 180 degrees is shown for purposes of example, the terrestrial transmissions may be in other ranges within the scope of this invention. In each case, however, the terrestrial transmissions from each transmitter 32 are in directions that are outside of the satellite receiving antenna look angle at any location and, with the terrestrial signal power limitation according to the invention, the terrestrial signals do not interfere with the satellite signals transmitted at the same frequency.

In another aspect of the invention, the user location itself may include a transmitter for directionally transmitting at a satellite frequency. Such transmission capability from the user location would allow wireless communication both to and from the user location. The transmissions from the user location would be limited so as to include no direction within the look angle of a nearby satellite receiving antenna and would be limited as to transmission power as discussed above with regard to other terrestrial transmissions.

In the multiple terrestrial transmitter application of the invention such as the arrangement depicted in FIGURE 3, it may be desirable, although not necessary, for the signals from the several transmitters 32 to be synchronized. The synchronization in this sense means that each transmitter transmits the same data at the same frequency so that it may be received substantially simultaneously at a user location which lies within the effective transmission area (the area defined by radius R) of two or more different transmitters. Thus, regardless of which transmitter 32 a user may direct their terrestrial receiving antenna to, the user receives the very same data as any other user of terrestrial signals at that frequency in the geographic service area. The transmitters may have associated with them signal synchronization means 44 for enabling this synchronized transmission. Those skilled in the art will appreciate that several different arrangements may be used to provide such synchronization. For example, the signal synchronization means 44 may comprise high speed communications links such as optical fiber or high speed electrical communications links for communicating data to be transmitted or synchronization signals between transmitters 32. Alternatively the synchronization means 44 may comprise high gain antennae for relaying the received signals from one transmitter 32 to the next.

Any such relaying antennae and high speed communication links are to be considered equivalent signal synchronization means according to the invention.

As discussed above, and referring again to FIGURE 1, the power level at which the terrestrial signals may be transmitted must be limited to prevent interference with the satellite signals transmitted at the same frequency. However, the transmission power must still be strong enough to produce a usable signal level at a distant location, location 14 for example. The power level of the terrestrially transmitted signals is highest near the transmitter and decreases as the distance from the transmitter increases. Thus, the transmission power is limited by the maximum terrestrial signal level at the potential satellite signal user location which is nearest to the terrestrial transmitter 20. The maximum terrestrial signal level at the nearest satellite user location to the terrestrial transmitter is a signal which produces a terrestrial input signal at a satellite receiving antenna at that nearest location which is just below the interference level with respect to the satellite input signals which may be received by the satellite receiving antenna at that location. The transmission power to produce signals of this strength at the nearest location to the terrestrial transmitter 20 represents the maximum allowable transmission power and determines the effective transmission range or area of the terrestrial transmitter. This maximum level and all transmission power levels below this maximum level are non-interfering power levels and produce non-interfering terrestrial input signals at any satellite receiving antenna in the effective transmission area of the terrestrial transmitter 20.

A certain area around the terrestrial transmitter may be designated an exclusion zone and the nearest location to the terrestrial transmitter may be defined as a location at the edge of the exclusion zone. In this case, the transmission power of the terrestrial transmitter is controlled so that the terrestrial signals are just below the interference power level at this "nearest location" at the edge of the exclusion zone. The terrestrial signal level at locations within the exclusion zone is at a level which could cause interference with satellite signals unless the satellite receiving antenna design is modified to increase the directionality of the antenna, that is, the difference between the gain provided to the satellite signals and the gain provided to the terrestrial signals.

It will be apparent that the maximum power level at which terrestrial signals may be transmitted in accordance with the invention is dependent in part upon the power level of the

satellite signals at the various user locations. As shown in FIGURES 1 and 4, one preferred form of the invention includes a terrestrial transmission power control arrangement or means 46 for determining the power level of the satellite signals and for using that power level to set the power level of the terrestrial transmitter 20. Referring now to FIGURE 4, the terrestrial transmission power level control means 46 may comprise a calibrated receiver or any other suitable device by which the satellite signal strength may be determined. The illustrated calibrated receiver includes a satellite receiving antenna 48, a down-converter 50, preferably a channel selector 52, and a detector amplifier 54. The illustrated calibrated receiver also includes a comparator 56 with a variable resistance device 57 connected to one comparator input. The other comparator input is connected to receive the signal from the detector amplifier 54. Comparator 56 has its output connected to a level control device 58 associated with the terrestrial transmitter 20.

The illustrated transmitter 20 includes an encoder 60, which receives and encodes an input for terrestrial transmission, and also includes a modulator 62 for providing the desired modulation for transmission. The level control device 58 is interposed between the modulator 62 and an up-converter 63 which converts the signals to the desired higher frequency for transmission. The converted signals are then amplified by the power amplifier 64 and directed to a transmitter antenna 66.

The power level control device 46 operates by continuously monitoring a satellite signal which, due to the particular satellite orientation and/or transmission power, is most susceptible to interference from the terrestrial transmitted signals. The satellite receiving antenna 48 is directed to receive the signal from that most susceptible satellite, and the received signal is down converted to an intermediate frequency by the down converter 50.

The down converted signal may be processed by the channel selector 52 to separate a single channel and this separated signal is then filtered and converted to a dc voltage signal by the detector amplifier 54. This dc voltage signal is representative of the power level of the received satellite signal, and is compared to a reference signal by the comparator 56. The reference signal is set by the variable resistance 57 initially so that the comparator output is zero. At this initial setting, the transmission power level of transmitter 20 is set at a maximum non-interfering power level. At this power level the terrestrial signals at the various locations beyond any exclusion zone around the transmitter 20 result in terrestrial

input signals which are below the interfering power level with respect to any satellite input signals at the same frequency. However, as the signal power of the satellite signals received at the antenna 48 changes over time, the output of comparator 56 causes the level control 58 to change the transmission power of the terrestrial transmitter 20 accordingly. When the satellite signal becomes weaker than at initial conditions, the comparator 56 output is less than zero and this causes the level control 58 to reduce the transmission power from transmitter 20. When the satellite signal becomes stronger, the comparator 56 output returns toward zero and this causes the level control 58 to increase the transmission power to transmitter antenna 66.

The method of the invention may now be described with particular reference to FIGURES 1 and 2. A first frequency is already in use for transmitting satellite signals from a satellite, satellite 12d for example, along the satellite signal 42 route to location 14. Satellite signals are received at the location 14 with the satellite receiving antenna 16 shown in FIGURE 2. Satellite receiving antenna 16 has a directional reception characteristic with a maximum gain along the antenna centerline 28 and lower gain at angles from the antenna centerline. The satellite receiving antenna 16 is oriented in a satellite reception position in which the satellite signal route 42 is within a look angle d_{max} on either side of, or about, the centerline 28 of the antenna. In this satellite reception position, the satellite signals produce a satellite input signal from the satellite receiving antenna 16 and this input signal is at least at the minimum usable signal level for the particular signal processing equipment.

The method of the invention includes transmitting terrestrial signals at the first frequency, that is, the same frequency at which the satellite signals are transmitted. The terrestrial signals are transmitted in directions which include the wireless transmission route 40 from the transmitter 20 to the location 14. According to the invention, the transmitter 20 is located such that the wireless transmission route 40 lies at an angle to the satellite receiving antenna centerline 28, and this angle is sufficiently large that the terrestrial signals present at the location 14 produce terrestrial input signals which are below the interference level with respect to the satellite input signals produced at the antenna 16. The terrestrial signals present at the location 14 are also at a power level at least at the minimum usable terrestrial signal level. At this minimum useable terrestrial signal level the terrestrial signals may be picked up by a terrestrial antenna 18 which may be at the user location 14. The

terrestrial antenna 18 is a directional antenna to ensure that the satellite signals do not interfere with the terrestrial signals.

Under current technology, the satellite signal level at any terrestrial user location may range from -120dBm to -125dBm under clear sky conditions and from -122dBm to -127dBm under more adverse weather conditions. Depending primarily upon the directionality of the satellite receiving antenna and the capabilities of the signal processing equipment associated with the satellite receiving antenna, terrestrial signal power level at the user location must remain below about -95dBm. This terrestrial signal power level assumes a satellite receiving antenna gain of approximately 34dB for the satellite signals and a gain of about -2dB for the terrestrial signals, and an interference level of approximately 4dB below the satellite input signal power level. Also, under current technology, the terrestrial input signals must remain about 4.5dB (3dB to 5dB) below the satellite input signals in order for the signal processing equipment to distinguish the satellite input signals and extract the desired data from the satellite input signals. Those skilled in the art will readily appreciate that the invention is not limited to these signal power values and that these values are provided for purposes of illustration and example.

Also according to the invention, the terrestrial transmitter 20 transmits only along wireless transmission paths which avoid interference with the satellite signals at any location within an effective transmission range of the terrestrial transmitter. That is, the wireless route 40 from the transmitter 20 to any location 14 is at an angle with respect to a properly aligned satellite receiving antenna at the respective location such that the terrestrial input signals from the satellite receiving antenna are always below the interference level with respect to the satellite input signals which may be produced from the satellite receiving antenna. To ensure the required terrestrial signal strength at any location, including those adjacent to the terrestrial transmission location, the method of the invention may also include monitoring the signal strength of the satellite signals and setting the terrestrial transmission power to the maximum non-interfering power level based upon that detected satellite signal strength.

Referring to FIGURE 3, the method also includes transmitting from a second terrestrial transmitter 32 to a second location which may be any location within range R from the second terrestrial transmitter. The wireless route from the second transmitter to

the second location is at an angle to a properly oriented satellite receiving antenna at the second location to produce terrestrial input signals below the interference level with respect to the satellite input signals which result from satellite signals received by the satellite receiving antenna at the second location.

5

EXAMPLE

A test was conducted using a mobile test antenna. The test equipment included a DBS receiving antenna connected to signal processing equipment. The signal processing equipment was connected to receive input signals from the DBS receiving antenna and operated to direct a desired channel output to a television. The DBS receiving antenna was a directional antenna providing a gain of between 31dB and 34dB across a look angle of approximately 5 degrees on either side of the antenna centerline. Antenna gain from the DBS receiving antenna ranged from -2dB to -16dB outside of the antenna look angle.

The test used a terrestrial transmitter having a directional transmitter antenna elevated to 52 feet AGL and directed with its peak power output at an azimuth of 180 degrees (due South), with true horizontal polarity. The terrestrial transmitter set up was not changed from this configuration throughout the test. Only the transmission power was varied as will be discussed below.

The interference test was conducted at several different test locations or user locations, each spaced apart from the terrestrial transmitter location. At each test location the DBS receiving antenna was first elevated to achieve a line of sight to the terrestrial transmitter and then oriented with its centerline aligned generally with the wireless transmission route from the terrestrial transmitter. Once a line of sight was verified between the DBS test antenna and the terrestrial transmitter, an isotropic receive power level was established from the terrestrial transmitter at full power, 29 dBm.

At each test location the DBS receiving antenna was then optimally positioned for receiving satellite signals from a particular DBS satellite, that is, the centerline of the DBS receiving antenna was aligned with the signal route from the satellite. The satellite signals at a particular frequency were received and fed to the television associated with the test apparatus. At each test site, the wireless transmission route from the terrestrial transmitter to the test site was outside of the look angle of the DBS receiving antenna optimally

30

positioned for receiving satellite signals from the DBS satellite. The terrestrial transmitter was operated to transmit at the same frequency as the received satellite signals, 12.470 gigahertz. In each test if there was interference with the received DBS satellite signals, as indicated by imperfect television reception, the terrestrial transmitter power was reduced until no interference was produced and this level, that is, the power level just below the interference level, was recorded.

At the weather conditions at which the tests were conducted, the satellite signal power level at each test site is calculated to be approximately -125dBm. Under these conditions a terrestrial transmission power level of 13dBm produced an exclusion zone in the transmission directions around the terrestrial transmitter of approximately one quarter mile while producing useable terrestrial signals at a location approximately 9.9 miles away from the terrestrial transmitting antenna. It is estimated that the terrestrial signal power level at this test site was approximately -137dBm.

The above described preferred embodiments are intended to illustrate the principles of the invention, but not to limit the scope of the invention. Various other embodiments and modifications to these preferred embodiments may be made by those skilled in the art without departing from the scope of the following claims.

CLAIMS:

1. A method for reusing a first transmission frequency already in use for transmitting satellite signals from a satellite along a satellite signal route to a first location for reception at a satellite receiving antenna which may be at the first location, such satellite receiving antenna producing a maximum gain for signals received along a satellite receiving antenna centerline and less gain at angles from said centerline, the satellite signals having a signal power level at the first location such that, when the satellite receiving antenna is placed in a satellite reception position in which the satellite transmission route lies within a satellite reception look angle about the satellite receiving antenna centerline, the satellite signals produce satellite input signals from the satellite receiving antenna which are at least at a minimum usable satellite input signal level, the method including the step of:

- (a) transmitting terrestrial signals at the first transmission frequency from a first terrestrial transmitter, the terrestrial signals being transmitted in directions including a wireless transmission route from the first terrestrial transmitter to the first location, and the wireless transmission route lying at an angle from the satellite receiving antenna centerline, when the satellite antenna is in the satellite reception position, such that the terrestrial signals present at the first location result in terrestrial input signals from the satellite receiving antenna which are at a power level less than an interference power level with respect to the satellite input signals, the terrestrial signals present at the first location having a power level at least at a minimum usable terrestrial signal level.

2. The method of claim 1 wherein:

- (a) the terrestrial signals are transmitted directionally in a limited azimuth range about the first transmitter.

3. The method of claim 1 further including:

- (a) transmitting along a plurality of wireless transmission routes from the first terrestrial transmitter, each wireless transmission route lying at an angle from a centerline of a satellite receiving antenna which may be aligned to receive satellite signals at any location along



such route, said angle being such that the terrestrial signals present at said location may result in terrestrial input signals from said satellite receiving antenna which are at a power level less than the interference power level with respect to satellite input signals which may result from the satellite signals received at said satellite receiving antenna.

- 5
4. The method of claim 1 wherein there is a second location at which a second satellite receiving antenna may receive satellite signals transmitted at the first frequency along a second satellite signal route from the satellite to the second location, the second satellite receiving antenna producing a maximum gain for signals received along a centerline of the second satellite receiving antenna, the satellite signals having a signal power level at the second location such that, when a second satellite receiving antenna is placed at the second location in a second satellite reception position in which the satellite transmission route lies within a satellite reception look angle about the centerline of the second satellite receiving antenna, the satellite signals result in satellite input signals from the second satellite receiving antenna which are at least at the minimum usable satellite input signal level, the method further including the step of:
- 10
- 15
- 20
- (a) transmitting terrestrial signals at the first transmission frequency from a second terrestrial transmitter at a second transmitter location, the second terrestrial transmitter having an effective transmission area which is different from an effective transmission area for the first terrestrial transmitter and the effective transmission area of the second terrestrial transmitter including the second location, the terrestrial signals from the second terrestrial transmitter being transmitted in directions including a wireless transmission route from the second terrestrial transmitter to the second location, the wireless transmission route to the second location lying at an angle from the centerline of the second satellite receiving antenna, when the second satellite receiving antenna is in the satellite reception position at the second location, such that the terrestrial signals from the second transmitter present at the second location result in terrestrial input signals from the second satellite receiving antenna which are at a power level less than the interference power level with respect to the satellite input signals.
- 25
- 30
- 35



5. The method of claim 4 wherein:
- (a) the first terrestrial transmitter and the second terrestrial transmitter simultaneously transmit the same data at the first transmission frequency.
- 5
6. The method of claim 5 wherein:
- (a) the effective transmission area of the first terrestrial transmitter overlaps with the effective transmission area of the second terrestrial transmitter.
- 10
7. The method of claim 4 wherein:
- (a) the effective transmission area of the first terrestrial transmitter and the effective transmission area of the second terrestrial transmitter do not overlap; and
 - (b) the first terrestrial transmitter and the second terrestrial transmitter simultaneously transmit different data at the first frequency.
- 15
8. The method of claim 1 further including the step of transmitting signals from a second terrestrial transmitter and wherein:
- (a) an effective transmission area of the first terrestrial transmitter and an effective transmission area of the second terrestrial transmitter overlap; and
 - (b) the first terrestrial transmitter and the second terrestrial transmitter each simultaneously transmit data at a different frequency.
- 20
- 25
- 30
- 35
9. The method of claim 1 wherein:
- (a) the satellite signals are transmitted from a plurality of satellites, each satellite transmitting satellite signals for reception within a satellite reception look angle about a different satellite antenna centerline from the first location to result in satellite input signals at the satellite antenna aligned along such centerline, the wireless transmission route lying at an angle from each satellite receiving antenna centerline such that the terrestrial signals present at the first location result in terrestrial input signals from the satellite receiving antenna aligned along any such centerline which terrestrial input signals are at a power level less than the interference level with respect to the satellite input signals.



10. The method of claim 1 further including the steps of:
- (a) substantially continuously detecting the satellite signal power level at a location near the first terrestrial transmitter; and
- (b) setting the transmission power of the first terrestrial transmitter to a non-interference level based upon the satellite signal power level detected near the first terrestrial transmitter, the non-interference level being a level ensuring that substantially each location within an effective transmission area around the first terrestrial transmitter receives terrestrial signals from the first terrestrial transmitter at a power level to produce non-interfering terrestrial input signals from a satellite receiving antenna aligned to receive satellite signals at said location, the non-interfering terrestrial input signals being at a power level less than the interference level with respect to the satellite input signals produced by the satellite reception antenna at said location.
11. An apparatus for simultaneously providing terrestrially transmitted signals on a common frequency with satellite signals transmitted from a satellite along a satellite signal route to a first location, the satellite signals being transmitted at a first frequency for reception at a satellite receiving antenna which may be at the first location, such satellite receiving antenna producing a maximum gain for signals received along a satellite receiving antenna centerline and less gain at angles to said centerline, the satellite signals having a signal power level such that, when the satellite receiving antenna is placed in a satellite reception position in which the satellite transmission route lies within a satellite reception look angle about the satellite receiving antenna centerline, the satellite signals result in satellite input signals from the satellite receiving antenna which are at least at a minimum usable satellite input signal level, the apparatus including:
- (a) a first terrestrial transmitter for transmitting signals at the first frequency along a wireless transmission route from a first terrestrial transmitter location to the first location, the wireless transmission route lying at an angle from the satellite receiving antenna centerline, when the satellite receiving antenna is in the satellite reception position, such that the terrestrial signals present at the first location result in terrestrial input signals from the satellite receiving antenna which are at a power level less than an



interference level with respect to the satellite input signals, the terrestrial signals present at the first location having a power level at least at a minimum usable terrestrial signal level.

- 5 12. The apparatus of claim 11 wherein:
 (a) the first terrestrial transmitter comprises a directional transmitter for directionally transmitting the terrestrial signals in a limited azimuth range about the first transmitter.

- 10 13. The apparatus of claim 11 wherein:
 (a) the first terrestrial transmitter transmits along a plurality of wireless transmission routes from the first terrestrial transmitter, each wireless transmission route lying at an angle from a centerline of a satellite receiving antenna which may be aligned to receive
 15 satellite signals at any location along such route, said angle being such that the terrestrial signals present at said location may result in terrestrial input signals from said satellite receiving antenna which are at a power level less than the interference level with respect to satellite input signals which may be produced from the
 20 satellite signals received at said satellite receiving antenna.

14. The apparatus of claim 11 further including:
 (a) a second terrestrial transmitter at a second transmitter location for transmitting terrestrial signals at the first frequency, the second terrestrial transmitter having an effective transmission area which is different from an effective transmission area for the first
 25 terrestrial transmitter.

15. The apparatus of claim 14 further including:
 (a) signal synchronization means associated with the first terrestrial transmitter and the second terrestrial transmitter, the signal synchronization means enabling the first terrestrial transmitter and the second terrestrial transmitter to simultaneously transmit the
 30 same data at the first frequency.

16. The apparatus of claim 15 wherein:
 (a) the effective transmission area of the first terrestrial transmitter overlaps with the effective transmission area of the second
 35 terrestrial transmitter.



17. The apparatus of claim 13 wherein:

- (a) the effective transmission area of the first terrestrial transmitter and the effective transmission area of the second terrestrial transmitter do not overlap; and
- (b) the first terrestrial transmitter and the second terrestrial transmitter simultaneously transmit different data at the first frequency.

18. The apparatus of claim 11 wherein:

- (a) the satellite signals are transmitted from a plurality of satellites, each satellite transmitting satellite signals for reception within a satellite reception look angle about a different satellite antenna centerline from the first location to result in satellite input signals at the satellite antenna aligned along such centerline, the wireless transmission route lying at an angle from each satellite receiving antenna centerline such that the terrestrial signals present at the first location result in terrestrial input signals from the satellite receiving antenna aligned along any such centerline which terrestrial input signals are at a power level less than the interference level with respect to the satellite input signals produced at the satellite receiving antenna.

19. The apparatus of claim 11 further including:

- (a) satellite signal power monitoring means for substantially continuously detecting the satellite signal power level at a location near the first terrestrial transmitter; and
- (b) transmission power adjusting means associated with the first terrestrial transmitter for setting the transmission power of the first terrestrial transmitter to a non-interference level based upon the satellite signal power level detected by the satellite signal power detection means, the non-interference level being a level ensuring that substantially each location within an effective transmission area around the first terrestrial transmitter receives terrestrial signals from the first terrestrial transmitter at a power level to produce non-interfering terrestrial input signals from a satellite receiving antenna aligned to receive satellite signals at said location, the non-interfering terrestrial input signals being at a power level less than the interference level with respect to the



satellite input signals produced by the satellite reception antenna at said location.

20. An apparatus for simultaneously providing terrestrially transmitted signals
 5 on a common frequency with satellite signals transmitted from a satellite,
 the satellite signals being transmitted at a first frequency along a satellite
 transmission route to a satellite receiving antenna at a location which
 may be anywhere within a geographic service area, the satellite receiving
 antenna producing a maximum gain for signals received along a satellite
 10 receiving antenna centerline and less gain at angles from said centerline,
 the satellite signals having a signal power level which, when the satellite
 receiving antenna is placed at a satellite reception position in which the
 satellite transmission route lies within a satellite reception look angle
 about the satellite receiving antenna centerline, results in satellite input
 15 signals from the satellite receiving antenna, the satellite input signals
 being at least at a minimum usable satellite input signal level, the
 apparatus including:

- (a) a plurality of spaced apart terrestrial transmitters, each terrestrial
 20 transmitter adapted for transmitting terrestrial signals at the first
 frequency, the plurality of spaced apart terrestrial transmitters
 being arranged such that substantially each respective location
 within the geographic service area has a wireless transmission
 route to one of the terrestrial transmitters, the wireless
 transmission route lying at an angle from the satellite receiving
 antenna centerline when the satellite receiving antenna is in the
 25 satellite reception position at the respective location such that the
 terrestrial signals present at the respective location are at least at
 a minimum usable terrestrial signal level but result in terrestrial
 input signals from the satellite receiving antenna which are at a
 power level less than an interference level with respect to the
 30 satellite input signals.

21. The apparatus of claim 20 wherein:

- (a) the plurality of terrestrial transmitters are further arranged such that
 35 substantially none of the terrestrial transmitters transmits in a path
 which lies at an angle from the centerline of the satellite receiving
 antenna in the satellite reception position at any location, such that
 the terrestrial signals present at said location result in an input



signal from the satellite receiving antenna which is at or above the interference power level with respect to the satellite input signal.

22. The apparatus of claim 20 further including:

- 5 (a) signal synchronization means associated with each terrestrial transmitter for enabling the terrestrial transmitters to simultaneously transmit the same signals at the first frequency.

23. The apparatus of claim 20 wherein:

- 10 (a) each terrestrial transmitter transmits across a common azimuth range from the respective transmitter location.

24. The apparatus of claim 20 wherein the first frequency is above about 1000 megahertz

15

25. The apparatus of claim 20 further including:

- (a) satellite signal power monitoring means for substantially continuously detecting the satellite signal power level at a location within the geographic service area; and
- 20 (b) transmission power adjusting means associated with the terrestrial transmitters for setting the transmission power of the terrestrial transmitters to a non-interference level based upon the satellite signal power level detected by the satellite signal power monitoring means, the non-interference level being a level
- 25 ensuring that substantially each location within the geographic service area receives terrestrial signals from each of the terrestrial transmitters at a power level to result in non-interfering terrestrial input signals from a satellite reception antenna aligned to receive satellite signals at said location, the non-interfering terrestrial input signals being at a power level less than the interference level with respect to the satellite input signal produced by the satellite reception antenna at said location.
- 30

26. A method for simultaneously providing terrestrially transmitted signals on a common frequency with satellite signals transmitted from a satellite, the satellite signals being transmitted at a first frequency along a satellite transmission route to a satellite receiving antenna at a location which may be anywhere within a geographic service area, the satellite receiving

35



antenna producing a maximum gain for signals received along a satellite receiving antenna centerline and less gain at angles from said centerline, the satellite signals having a signal power level which, when the satellite receiving antenna is placed at a satellite reception position in which the satellite transmission route lies within a satellite reception look angle about the satellite receiving antenna centerline, results in satellite input signals from the satellite receiving antenna, the satellite input signals being at least at a minimum usable satellite input signal level, the method including the steps:

- 5
- 10 (a) transmitting terrestrial signals at the first frequency from a plurality of spaced apart terrestrial transmitters, the plurality of spaced apart terrestrial transmitters being arranged such that substantially each respective location within the geographic service area has a wireless transmission route to one of the terrestrial transmitters,
- 15 the wireless transmission route lying at an angle from the satellite receiving antenna centerline when the satellite receiving antenna is in the satellite reception position at the respective location such that the terrestrial signals present at the respective location are at least at a minimum usable terrestrial signal level but result in
- 20 terrestrial input signals from the satellite receiving antenna which are at a power level less than an interference level with respect to the satellite input signals.

27. The method of claim 26 further including:

- 25 (a) simultaneously transmitting the same terrestrial signals at the first frequency from the plurality of terrestrial transmitters.

28. The method of claim 26 wherein:

- 30 (a) the satellite signals are transmitted from a plurality of satellites, each satellite transmitting satellite signals for reception within a different satellite reception look angle from each location in the geographic service area.

29. The method of claim 26 wherein:

- 35 (a) each terrestrial transmitter transmits across a common azimuth range from the respective transmitter location.



30. The method of claim 26 wherein the first frequency is above about 1000 megahertz.
31. The method of claim 26 wherein:
- 5 (a) the plurality of terrestrial transmitters are further arranged such that substantially none of the terrestrial transmitters transmits in a path which lies at an angle from the centerline of the satellite receiving antenna in the satellite reception position at any location, such that the terrestrial signals present at said location result in input signals from the satellite receiving antenna which are at or above the
- 10 interference power level with respect to the satellite input signals.
32. A method for reusing a first transmission frequency already in use for transmitting satellite signals from a satellite along a satellite signal route to a first location for reception at a satellite receiving antenna which may be at the first location, the satellite signals having a sufficient signal power level at the first location to result in satellite input signals from the satellite receiving antenna which are at least at a minimum usable satellite input signal level, the method including the step of:
- 15 (a) transmitting terrestrial signals at the first transmission frequency from a first terrestrial transmitter, the terrestrial signals present at the first location resulting in terrestrial input signals from the satellite receiving antenna which are at a power level less than an interference power level with respect to the satellite input signals, the terrestrial signals present at the first location having a power level at least at a minimum usable terrestrial signal level.
- 20
33. A method for reusing a first transmission frequency already in use for transmitting satellite signals from a satellite along a satellite signal route to a first location for reception at a satellite receiving antenna which may be at the first location, such satellite receiving antenna producing a maximum gain for signals received along a satellite receiving antenna centerline and less gain at angles from said centerline, the satellite signals having a signal power level at the first location such that, when the satellite receiving antenna is placed in a satellite reception position in which the satellite transmission route lies within a satellite reception look angle about the satellite receiving antenna centerline, the satellite signals produce satellite input signals from the satellite receiving antenna which
- 25
- 30
- 35



are at least at a minimum usable satellite input signal level, the method being substantially as described with reference to the drawings.

- 5 34. An apparatus for simultaneously providing terrestrially transmitted signals on a common frequency with satellite signals transmitted from a satellite along a satellite signal route to a first location, the satellite signals being transmitted at a first frequency for reception at a satellite receiving antenna which may be at the first location, such satellite receiving antenna producing a maximum gain for signals received along a satellite receiving antenna centerline and less gain at angles to said centerline, 10 the satellite signals having a signal power level such that, when the satellite receiving antenna is placed in a satellite reception position in which the satellite transmission route lies within a satellite reception look angle about the satellite receiving antenna centerline, the satellite signals result in satellite input signals from the satellite receiving antenna which 15 are at least at a minimum usable satellite input signal level, the apparatus being substantially as described with reference to the drawings.

- 20 35. An apparatus for simultaneously providing terrestrially transmitted signals on a common frequency with satellite signals transmitted from a satellite, the satellite signals being transmitted at a first frequency along a satellite transmission route to a satellite receiving antenna at a location which may be anywhere within a geographic service area, the satellite receiving antenna producing a maximum gain for signals received along a satellite receiving antenna centerline and less gain at angles from said centerline, 25 the satellite signals having a signal power level which, when the satellite receiving antenna is placed at a satellite reception position in which the satellite transmission route lies within a satellite reception look angle about the satellite receiving antenna centerline, results in satellite input signals from the satellite receiving antenna, the satellite input signals being at least at a minimum usable satellite input signal level, the apparatus being substantially as described with reference to the drawings. 30

- 35 36. A method for simultaneously providing terrestrially transmitted signals on a common frequency with satellite signals transmitted from a satellite, the satellite signals being transmitted at a first frequency along a satellite transmission route to a satellite receiving antenna at a location which



5 may be anywhere within a geographic service area, the satellite receiving antenna producing a maximum gain for signals received along a satellite receiving antenna centerline and less gain at angles from said centerline, the satellite signals having a signal power level which, when the satellite receiving antenna is placed at a satellite reception position in which the satellite transmission route lies within a satellite reception look angle about the satellite receiving antenna centerline, results in satellite input signals from the satellite receiving antenna, the satellite input signals being at least at a minimum usable satellite input signal level, the method being substantially as described with reference to the drawings.

10

- 15 37. A method for reusing a first transmission frequency already in use for transmitting satellite signals from a satellite along a satellite signal route to a first location for reception at a satellite receiving antenna which may be at the first location, the satellite signals having a sufficient signal power level at the first location to result in satellite input signals from the satellite receiving antenna which are at least at a minimum usable satellite input signal level, the method being substantially as described with reference to the drawings.
- 20

P
R
I
O
RP
R
I
O
RP
R
I
O
R

Figure 1

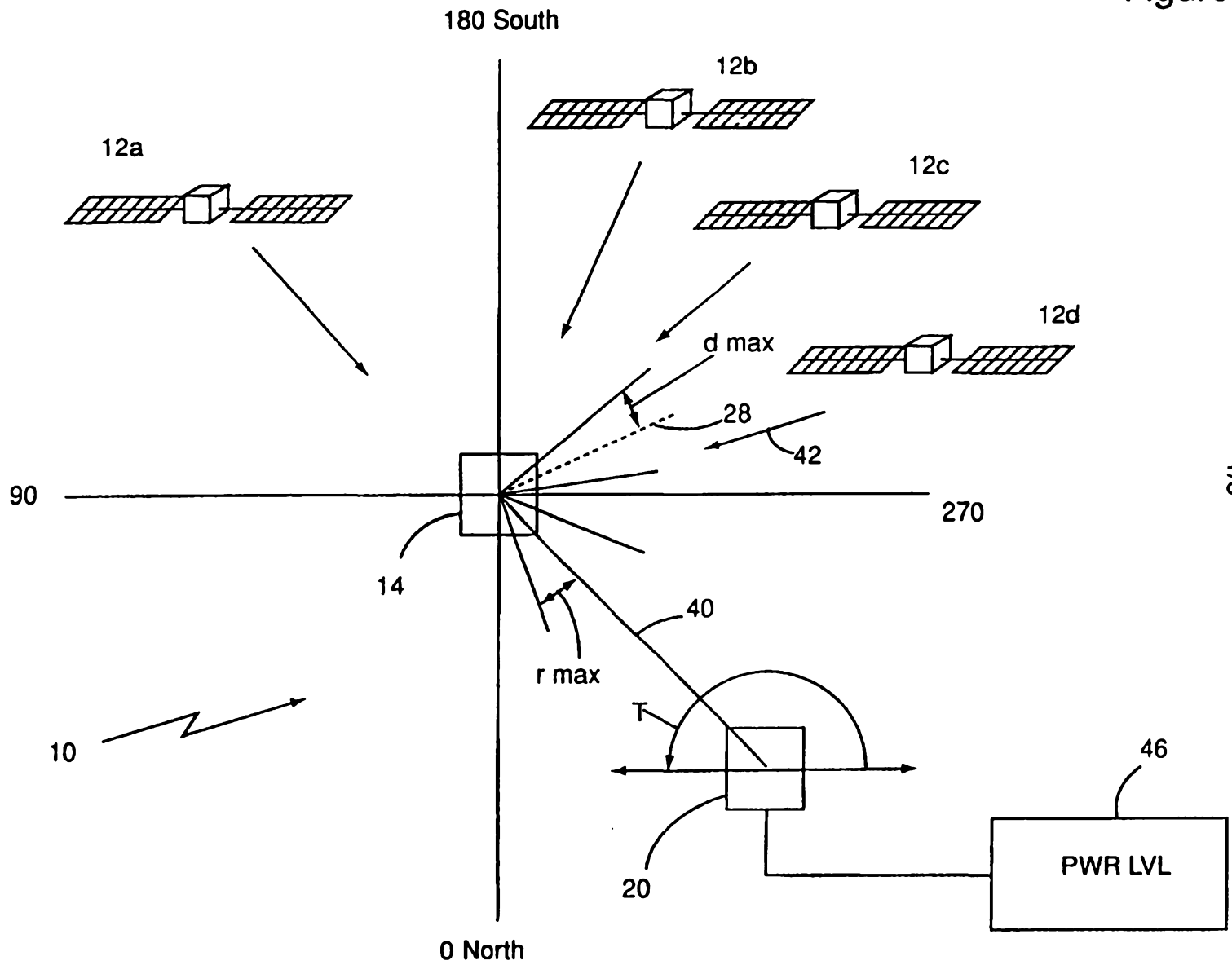

Figure 2

2/3

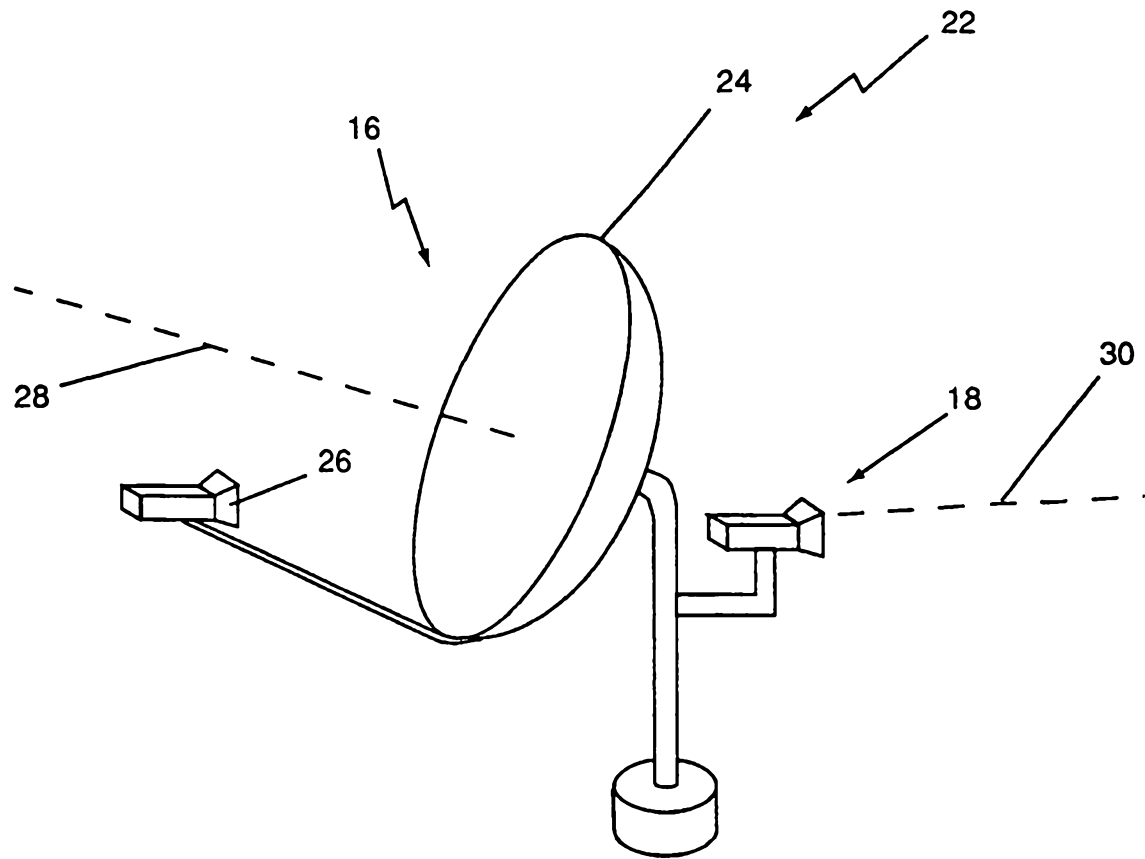

Figure 3

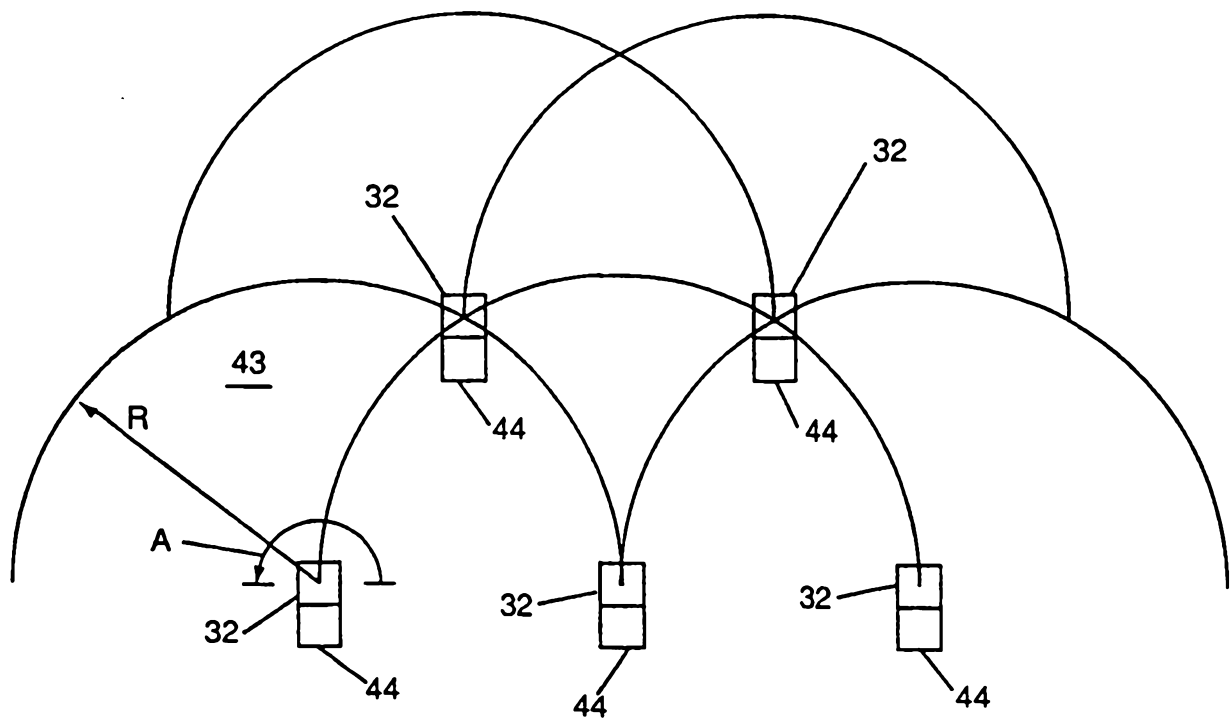

Figure 4

3/3

