



- (51) **International Patent Classification:**
H04B 17/00 (2006.01)
- (21) **International Application Number:**
PCT/US2011/024000
- (22) **International Filing Date:**
8 February 2011 (08.02.2011)
- (25) **Filing Language:** English
- (26) **Publication Language:** English
- (30) **Priority Data:**
12/706,001 16 February 2010 (16.02.2010) US
- (71) **Applicant (for all designated States except US):** ANDREW LLC [US/US]; 1100 Commscope Place, SE, Hickory, NC 28602-3618 (US).
- (72) **Inventors; and**
- (75) **Inventors/Applicants (for US only):** HOBBS, Neil [US/US]; 311 Valleywood Drive, Forest, VA 24551 (US). SCHMIDT, Nelson, C., Jr. [US/US]; 35 Primose Lane, Lexington, VA 24450 (US). KUMMETZ, Thomas [DE/US]; 1903 Rock Branch Drive, Forest, VA 24551 (US). PHILLIPS, Fred [US/US]; 212 Kingston Drive, Forest, VA 24551 (US).
- (74) **Agents:** SUMME, Kurt, A. et al.; Wood, Herron & Evans, LLP, 2700 Carew Tower, 441 Vine Street, Cincinnati, OH 45202-2917 (US).

- (81) **Designated States (unless otherwise indicated, for every kind of national protection available):** AE, AG, AL, AM, AO, AT, AU, AZ, BA, BB, BG, BH, BR, BW, BY, BZ, CA, CH, CL, CN, CO, CR, CU, CZ, DE, DK, DM, DO, DZ, EC, EE, EG, ES, FI, GB, GD, GE, GH, GM, GT, HN, HR, HU, ID, IL, IN, IS, JP, KE, KG, KM, KN, KP, KR, KZ, LA, LC, LK, LR, LS, LT, LU, LY, MA, MD, ME, MG, MK, MN, MW, MX, MY, MZ, NA, NG, NI, NO, NZ, OM, PE, PG, PH, PL, PT, RO, RS, RU, SC, SD, SE, SG, SK, SL, SM, ST, SV, SY, TH, TJ, TM, TN, TR, TT, TZ, UA, UG, US, UZ, VC, VN, ZA, ZM, ZW.
- (84) **Designated States (unless otherwise indicated, for every kind of regional protection available):** ARIPO (BW, GH, GM, KE, LR, LS, MW, MZ, NA, SD, SL, SZ, TZ, UG, ZM, ZW), Eurasian (AM, AZ, BY, KG, KZ, MD, RU, TJ, TM), European (AL, AT, BE, BG, CH, CY, CZ, DE, DK, EE, ES, FI, FR, GB, GR, HR, HU, IE, IS, IT, LT, LU, LV, MC, MK, MT, NL, NO, PL, PT, RO, RS, SE, SI, SK, SM, TR), OAPI (BF, BJ, CF, CG, CI, CM, GA, GN, GQ, GW, ML, MR, NE, SN, TD, TG).

- Published:**
- with international search report (Art. 21(3))
 - before the expiration of the time limit for amending the claims and to be republished in the event of receipt of amendments (Rule 48.2(h))

(54) **Title:** GAIN MEASUREMENT AND MONITORING FOR WIRELESS COMMUNICATION SYSTEMS

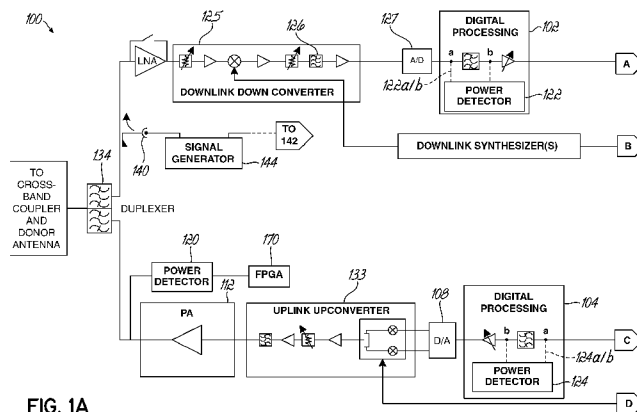

FIG. 1A

(57) **Abstract:** A method of monitoring an element in wireless communication system is provided. An operational noise measurement is obtained by measuring a noise value outside of a bandwidth (304) of a first device, but within a bandwidth (302) of a second, subsequent device. The operational noise measurement is alternatively obtained by tuning an input band of the element to shift the input band partially or completely outside of a bandwidth (404) of a first device to create an open band or by suppressing an input of the antenna and measuring noise within the open bandwidth of the element of the wireless communication network. A stored parameter is retrieved and compared to the measured operational noise. Alternatively, a leakage signal of the element may be received at a signal receiver and compared to a reference. The reference is a function of components of the wireless communication system in a leakage path of the leakage signal.

WO 2011/102987 A1

GAIN MEASUREMENT AND MONITORING FOR WIRELESS COMMUNICATION SYSTEMS

FIELD OF THE INVENTION

[0001] The present invention is directed to wireless transceiver systems for use in wireless communication systems, and specifically is directed to gain monitoring in the wireless transceiver systems.

BACKGROUND OF THE INVENTION

[0002] Contemporary cellular phone systems and broadband wireless metropolitan networks are generally divided into a number of cells distributed in a pattern to preclude co-channel interferences and provide coverage of mobile and fixed subscriber units operating within the service area of the system. Each cell generally includes a base station that employs radio frequency (RF) transceiver equipment, antennas, and wire line communication equipment. In addition, some cells also include repeaters, distributed antenna systems (DAS), and/or remote radio heads in order to extend the coverage of the base station over longer distances, throughout buildings or tunnels, around obstacles, etc. These coverage extension elements, hereafter generically referred to as “repeaters”, serve to filter, amplify, and re-radiate signals in both directions, from the base station to subscriber units (the “downlink” direction), and from subscriber units back to the base station (the “uplink” direction).

[0003] A repeater is normally configured to provide either a fixed amount of output power or a fixed amount of gain in each direction. Maintaining the desired operating levels is critical to achieving optimal network coverage and performance. Simply measuring the output power of the repeater at any given time is inadequate to guarantee proper operation, as the input signal levels may vary over time.

[0004] Therefore there is a need in the art for an inexpensive system able to monitor the total system gain and overall performance of a repeater, and to provide an indication if its performance falls outside pre-determined limits.

SUMMARY OF THE INVENTION

[0005] Embodiments consistent with the invention provide a method of monitoring at least one element of a wireless communication system. An operational noise measurement may be obtained by measuring a noise value outside of a bandwidth of a first device, but within a bandwidth of a second, subsequent device. A stored parameter may be retrieved and the measured operational noise measurement may be compared to the retrieved parameter.

[0006] In other embodiments an input band of the element of the wireless communication system may be tuned to shift the input band partially or completely outside of a bandwidth of a first device to create an open band. An operational noise level may be measured in the open band. A stored parameter is retrieved and may be compared to the measured operational noise level.

[0007] In still other embodiments, an operational noise level by may be obtained by suppressing an input of the antenna and measuring noise within a bandwidth of the element of the wireless communication network. A stored parameter is retrieved and compared to the measured operational noise level.

[0008] Some embodiments receive a leakage signal of the element of the wireless communications system at a signal receiver. The received leakage signal may then be compared to a reference. The reference may be a function of components of the wireless communication system in a leakage path of the leakage signal.

BRIEF DESCRIPTION OF THE DRAWINGS

[0009] The accompanying drawings, which are incorporated in and constitute a part of this specification, illustrate embodiments of the invention and, together with a general description of the invention given above, and the detailed description given below, serve to explain the invention.

[0010] FIGS. 1A and 1B contain a block diagram of an exemplary repeater consistent with embodiments of the invention.

[0011] FIG. 2 is a graph illustrating unused segments of an input band.

[0012] FIG. 3 is a graph illustrating available segments of a filter band around an input band.

[0013] FIG. 4 is a graph illustrating frequency shifting an input band to create an unused segment.

[0014] FIGS. 5A and 5B contain an alternate embodiment of the block diagram of the repeater in FIGS. 1A and 1B.

[0015] FIG. 6 contains an embodiment of a repeater indicating characterized leakage paths.

- [0016] FIG. 7 contains an embodiment of a repeater indicating characterized leakage paths.
- [0017] FIG. 8 contains an embodiment of a repeater indicating characterized leakage paths.
- [0018] FIG. 9A and 9B are flowcharts for detecting front-end failures.
- [0019] FIG. 10A and 10B are flowcharts for detecting back-end failures.
- [0020] It should be understood that the appended drawings are not necessarily to scale, presenting a somewhat simplified representation of various features illustrative of the basic principles of the invention. The specific design features of the sequence of operations as disclosed herein, including, for example, specific dimensions, orientations, locations, and shapes of various illustrated components, will be determined in part by the particular intended application and use environment. Certain features of the illustrated embodiments have been enlarged or distorted relative to others to facilitate visualization and clear understanding. In particular, thin features may be thickened, for example, for clarity or illustration. Also, where appropriate, similar reference numbers have been used to indicate like parts.

DETAILED DESCRIPTION OF THE INVENTION

- [0021] Embodiments of the present invention are directed to an apparatus and method of measuring or monitoring gain in a wireless communication system. Measurements of gain may be used for additional diagnostics, such as fault detection. For example, service providers are interested in knowing whether an amplifier in the communication system has blown or whether another component has failed, such that the communication system is not operating properly, in order to quickly service or replace the

repeater or component. Some contemporary communication systems use power detectors to monitor or measure output power; however, such solutions cannot measure total system gain or identify fault conditions in a repeater because the input signal level is not known. A second detector could be placed at the repeater input, but this solution would be expensive due to the additional hardware and high dynamic range required. Instead, the various embodiments of the present invention offer lower cost solutions for total system gain measurement and fault detection. The methodology of the embodiments of the invention disclosed herein is illustrated in the form of a repeater; however, the methodology is generic enough to measure gain in many related types of wireless communication system elements, such as Distributed Antenna Systems (DAS) and remote radio heads (RRH), as well as RF amplifiers where gain may be similarly measured.

[0022] While various approaches to measuring the repeater or other wireless communication system element gains are available, each approach has its relative advantages and disadvantages. One approach employed by embodiments of the invention measures and/or monitors front end (low noise amplifier and down-converter) and back end (up-converter and power amplifier) gains together. Some embodiments measure/monitor the front and back end gains separately. Regardless of the approach, the gains may be compared to predetermined threshold values for a determination of the state of the device. Additionally, the approach may measure/monitor all of the front end and/or back end gains, or may only measure portions of those sections.

Overview

[0023] Embodiments of the invention employ methods to measure gain in a system element in a wireless communication system. These elements may include repeater systems, distributed antenna systems (DAS), remote radio heads (RRH), and/or RF amplifiers as well as any combination of the elements. The determination of the gain in the embodiments is performed by the measurement of the gain in various sections of the system element, which are typically front-ends and back-ends. The system gain is then determined by multiplication (or addition if the gain measurements are in decibel) of the elements of a cascade. Methods for determining front-end and back-end gain are briefly presented with detailed descriptions of the methods to follow.

[0024] In one embodiment for determining front end gain, a noise level in an unoccupied part of the receiver spectrum is measured. The front-end section gain may be determined through the ratio of the measured noise level to an equivalent input noise level. The equivalent input noise level may be determined by the front-end section noise as a stored reference value for the various settings of the front-end section and a thermal noise level at the current temperature, where the temperature may be determined by an on-board sensor. In an alternate embodiment for determining front end gain, the down-converter local oscillator may be shifted into a first receive band filter rejection band such that there is an unoccupied part of the spectrum when a noise measurement may be measured. Once measured, the gain for this embodiment may be determined similar to that of the embodiment above.

Alternately, the receive antenna may be disconnected by using a RF switch or otherwise suppressed to create an unoccupied part of the spectrum for a noise measurement. Gain may then be determined as set forth above.

[0025] In one embodiment for determining a back-end gain, a signal level may be measured at the input of the back-end. The signal at the output of the back-end may also be measured and the gain may then be determined from the ratio of the two measurements or the difference if the signals are represented as decibels. In an alternate embodiment, the signal level may be measured at the input to the back-end as well as a measurement of the spill-over of the back-end output that is received via a pre-determined leakage of the duplexer filter or an over-the-air leakage of known value into the front-end of the opposite direction link. The back-end gain may then be determined by determining the ratio between front-end output of the signal level and back-end input under consideration of the front-end gain as determined in an open band of the front end as set forth above and the pre-determined leakage between front-end and back-end. In another embodiment for determining back end gain, the signal level may be measured at the input to the back-end as well as a measurement of the leakage of the back-end output that is received via an external, controllable, and determined leakage path of known value into the front-end of the same direction link. The back-end gain may then be determined by determining the ratio between front-end output of the signal level and back-end input under consideration of the front-end gain as determined in using an open band of the front end as set forth above and the determined leakage between front-end and back-end.

[0026] The system element gain may be determined by the application of any combination of the front end gain embodiments and the back end gain embodiments, which may be appropriate and suitable for the specific system. Additionally, the system gain, front-end section gain, or back-end section gain may be compared to a stored reference value. Any deviation from this comparison exceeding a predetermined threshold may trigger an alarm.

[0027] In general, back-end gain determination is more straight forward than front-end gain determination. Therefore, the discussion below will begin with several methods for determining Back-End gain and then several methods for determining Front-End gain.

Back-End Gain

[0028] As used in this document, the “back-end” portion of the communication system may be defined as all of the components from a reference point to an output antenna. This may include all, part, or none of a digital signal processing section close to an input of the back-end. The back-end section of the system may include, in any order, one or more amplifiers, one or more amplifiers plus one or more filters, one or more amplifiers and filters plus one or more frequency mixers, or one or more D/A converters with or without additional components. The back-end section of the system may also include various other components such as attenuators and the like. Referring to the block diagram of an exemplary repeater 100 in FIG. 1A, the “back-end” may include all of the main signal path elements from the signal power measurement receiver connected to reference point 124a or 124b through the Duplexer 134. For the purpose of a back-end gain measurement a reference point 124b may be preferred as it would only measure the

relevant signal spectrum that will be fed into the back-end line-up. For the purpose of front-end measurements, reference point 124a may be preferred, though either reference point may be used for either front-end or back-end measurements.

[0029] In some embodiments, power detector 120 may be a wide band element configured to measure RMS power, but may as well be band-limited or time window limited. In other embodiments, a spectrum analyzer or a signal measurement receiver with configurable RF and IF measurement bandwidths and configurable power detectors may be used as well. Still other embodiments may employ an equivalent digital signal implementation of a band-limited or a band-unlimited power detector. The power detector may be connected anywhere along the component line-up depending on the specific needs.

[0030] Referring again to the block diagram of an exemplary repeater 100 in FIGS. 1A and 1B, when considering back-end gain determination, the amount of total composite power that digital sections 102, 104 (before upconverters 129, 133) are sending to the digital-to-analog converters ("DAC") 106, 108 will already be known as it is easily computed from the digitized signal waveform captured at reference point 124a or 124b in the digital section 104. Composite power at the output of power amplifiers ("PA") 110, 112 is also readily measureable. With these known composite power values, back end gain may be calculated by subtraction for level values represented in decibels or signal level division if linear level representations are used. These calculations use the assumption that no extra signals of significant power level are generated between the reference point 122a or

122b and the output of power amplifier 110 or the reference point 124a or 124b and the output of power amplifier 112. Readings from power detectors 116, 120, 122, and 124 and the corresponding exact transmit gain may be calibrated at factory test time. Depending on the application, inexpensive power detectors, such as the LMV225/226/228 series from National Semiconductor or the MAX 2206/2207/2208 from Maxim, for example, may be used for back-end gain determination. These particular detectors offer a limited dynamic range of approximately 30-40 dB.

[0031] For the downlink direction, 30-40 dB of range would likely be sufficient. However, in the uplink direction, there may be times when the output level is too small to read with the power detectors 120, 124, which would potentially cause false failure alarms. These false alarms could be avoided by using a higher dynamic range detector. Alternatively, an inexpensive detector may still be used if the gain measurement is disregarded any time the DAC 106, 108 drive level is small. False alarms may then be avoided simply by ignoring those readings. In other words, the uplink transmitter gain would only be monitored or measured when a “large enough” signal is present, for example, greater than approximately -90 to -80 dBm at the repeater input, depending on repeater gain settings and maximum output power.

Front-End Gain

[0032] As used in this document, the “front-end” portion of the communication system can be defined as everything between the input antenna and a reference point of the system. This may include all, part, or none of a digital signal processing section close to the output of the front-end.

The front-end section of the system may include, in any order, one or more amplifiers, one or more amplifiers plus one or more filters, or one or more amplifiers and filters plus one or more frequency mixers. The front-end section of the system may also include various other components such as A/D converters 127, attenuators, and the like. Referring to the block diagram of an exemplary repeater 100 in FIG. 1A, the "front-end" would comprise all of the main signal path elements, such as amplifiers and a down converter 125 having mixers, amplifiers, and filters to perform down conversion plus A/D converter 127, from the duplexer 134 through the signal power measurement receiver, power detector 122, capturing the signal at reference point 122a or 122b (A similar front end for the uplink direction would include all of the main signal path elements, such as amplifiers and a down converter 131 having mixers, amplifiers, and filters for down conversion and A/D converter 135). For the purpose of the front-end gain measurement a reference point 122a before the filter may be preferred as it allows more flexibility with respect to the frequency of the signal measurement taken, though the reference point after the filter 122b may also be used.

[0033] Power detectors 122, 124 may be implemented in a variety of ways. The power detector may be a wide band element configured to measure RMS power, but for the purpose of the front-end gain, should be band-limited. The power detector may be time window limited as well. A spectrum analyzer or a signal measurement receiver with configurable RF and IF measurement bandwidths and configurable power detectors may also be used. The equivalent digital signal implementation of a band-limited or a band-unlimited power detector may be another alternative.

[0034] Detecting front-end gain presents a more challenging problem than measuring back-end gain due to the unknown signals being received in the uplink and downlink directions. However, the overall repeater system has an existing operational noise level that is known. The front-end detection may utilize this known noise level and measure a difference between a threshold noise level that may be previously determined and stored (for example, during factory calibration) and an existing operational noise level. The operational noise level is measured during operation of the repeater. The operational measurement may then be compared to the stored, calibrated noise floor. An operational measurement resulting in a difference or delta that exceeds a pre-determined threshold may indicate that a device or amplifier within the repeater has failed or is malfunctioning. While seemingly straight forward, the measurement of the operational noise in bands with signals can be challenging.

[0035] A first embodiment of the front-end gain detection, as illustrated in the graph 200 in FIG. 2, utilizes a band-limited noise power measurement in an unused segment 202a, 202b, 202c of the band 204. The digital sections 102, 104 may include built-in measurement receivers/power detectors 122, 124 as shown in FIGS. 1A and 1B. The power detectors 122, 124 may be utilized to measure the noise floor 206 and compare it with a stored/calibrated level that was previously measured. Any deviation from the original calibrated down converter gain, such as that caused by amplifier failure, temperature, or aging, may generally show up as a difference in noise levels. For example, if a device fails, the operational noise floor will likely drop. The unused segments 202a, 202b, 202c may move within the band depending on where

signals 208 are received, or the unused segments 202a, 202b, 202c may be reserved segments, or guard bands, used to isolate adjacent bands. While this embodiment is simple to implement, it requires that there be at least one unused band that can be utilized for the noise measurements.

[0036] When the band is fully occupied, the first embodiment above cannot be used. However, in some embodiments of the repeater 100 and as illustrated in the graph 300 in FIG. 3, the IF filters 126, 132 in FIGS. 1A and 1B, together with any other intervening RF or IF filters that may optionally be included, may have a wider bandwidth 302 than the bandwidth 304 of the duplexers 134, 136. In some embodiments, the IF filters may be implemented as SAW filters. Alternatively, the wider bandwidth filtering may be accomplished at baseband frequencies, implemented as analog and/or digital filters. Therefore, a usable portion 306a, 306b of the spectrum exists that sees the full down-converter gain but does not contain outside interference from signals 308 which would overwhelm the noise floor 310. Operational noise may be measured in the bands 306a, 306b outside of the duplexer band 304 and compared with the stored/calibrated level that was measured during factory test. As with the previous embodiment, any deviation from the original calibrated down converter gain, such as that caused by amplifier failure, temperature, or aging, may generally show up as a difference in noise levels.

[0037] For bands where the IF filters 126, 132 do not have extra bandwidth, the system may behave like the first front-end embodiment described above. Most applications may still have enough gaps between the received signals due to frequency re-use patterns, guard bands, etc. that the measurement receiver may find a reasonable noise floor. In the few cases

which do not have gaps that allow precise measurement, failures may not be able to be detected, however, there will also not be false "receiver failure" alarms, because the signal level will be higher, not lower, than the calibrated noise level.

[0038] Situations and configurations may exist where the IF filters 126, 132 do not have extra bandwidth beyond the bandwidth of the duplexers, for example, and as illustrated in the graph 400 in FIG. 4, the bandwidth 402 of the IF filters 126, 132 is the same or narrower than the bandwidth 404 of the duplexers 134, 136. In an alternate embodiment for this inventive configuration, the receiver may be intentionally mistuned to be briefly shifted as shown in the window 406 to look at a frequency range outside of the input duplexer filter bandwidth 404. After shifting, a usable portion 408 of the spectrum now exists that sees the full down-converter gain but does not contain outside interference from signals 410, which would overwhelm the noise floor 412. In this embodiment, local oscillators may be shifted by a few MHz and allow for a noise 412 measurement to be made in the small band 408 outside the duplexer bandwidth 404. As with the previous embodiment, any deviation from the original calibrated down converter gain, such as that caused by amplifier failure, temperature, or aging, may generally show up as a difference in noise levels. If thresholds are exceeded, failure alarms may be sent.

[0039] In some repeaters, the transmitters and receivers of the repeater may have separate local oscillators. This separation may allow for continued repeating of the vast majority of the band 414 during the shifting 406 operation. In other embodiments, if the full bandwidth is not being used, for

example, the power detectors 122, 124 (FIGS. 1A and 1B) may look to the unused portion first even though rest of band may be full. If there are no unused portions, briefly frequency shifting the duplexer band 404 may be performed as set forth above. In other embodiments, the frequency shift may be permanently set during installation if there is no intention to repeat signals near one of the band edges.

[0040] Frequency shifting may also be implemented in an embodiment having a IF filter with a bandwidth greater than the duplex filter. If the bandwidths are close, the input signal band may be shifted toward one end of the IF filter band, creating a larger band for noise measurement. In this embodiment, the full signal (duplexer) bandwidth may be processed by adjusting the up-converter to shift the band back. Other combinations of the above embodiments may also be made to facilitate noise measurements for evaluating the front-end gains.

[0041] In an alternate embodiment of the repeater 500 in FIGS. 5A and 5B, high isolation switches 550, 552 may be implemented after the duplexer filters 534, 536, but before the low noise amplifiers 554, 556 at the front-end. The switches 550, 552 terminate the antennas 558, 560 such that the receiver would be switched to purely noise input for a brief period of time. During the brief period with no signal from the antennas, noise may be measured anywhere in the communication band. As with the previous embodiments, power detectors 522, 524 may be utilized to measure the operation noise and compare it with a stored/calibrated level that was previously measured. Again, any deviation from the original calibrated down-converter gain, such as that caused by amplifier failure, temperature, or aging, may generally show up

as a difference in noise levels, indicating a potential problem with the repeater 500. Because this embodiment completely interrupts the repeating function of the repeater, the switching and noise testing would likely be performed during non-peak hours, with the interruptions being of short durations, allowing for the noise testing to be accomplished. The antennas 558, 560 would then be switched back and normal operation of the repeater would then resume. In other embodiments, the switches 550, 552 which terminate the antennas may be replaced by other components that suppress signals received by the antennas without having to terminate the antennas 558, 560. Still other embodiments may inject amplified signals which may be used for gain determination without having to terminate the antennas 558, 560.

[0042] Alternatively, a signal may be generated by a signal generator 574 that could be injected into the front end at 570 and 572. This may occur with the antenna input suppressed or attenuated or by injecting amplified signals as set forth above, depending upon the level of the signal. The signal type could include amplified noise, a continuous wave tone, or some other signal type including a signal source modulated with a pseudo random bit sequence. Utilizing this approach may assist in reducing the suppression/attenuation requirement of the antenna input.

Gain Determination from Leakage Paths

[0043] In the embodiments discussed above, additional circuitry may be required for the gain measurement of the back-end path or transmit path. Additionally, front-end and back-end gains are determined separately. Turning to the embodiment of the repeater 600 in FIG. 6, known leakage paths in this embodiment allow for the measurement of the gain of both the

back-end transmit section and the front-end receive section (in its simplest form represented by amplifiers 608 and 610, respectively) at the same time as a combined measurement of front-end section and back-end section without the need, in some embodiments, for any additional hardware. Signal generation and measurements may be accomplished in the digital signal processing sections of the repeater without requiring hardware changes. The generation and measurements may be accomplished, in some embodiments, with only updates to software, for example.

[0044] One possible leakage path that may be used to determine the gain in both front-end and back-end sections in the repeater 600 may be leakage 602 through the duplex filters 604a and 604b in duplexer 604. The duplex filters 604a, 604b have predefined rejection of the transmit signals in the receive band. The rejection may be determined and calibrated in the factory over the entire frequency band. The signal received at signal receiver 606 is a known signal strength representing the total gain of the transmit and receive sections from the known gain of amplifier 608, coupling of duplexer 604, and gain of amplifier 610. This signal may be system noise in an empty band as with the embodiments discussed above, or alternatively in some embodiments, a pilot signal may be generated from a pilot signal generator 612. The pilot signal may be generated in an empty band and may be used to test the gain of the system. When the overall gain from either noise or the pilot signal drops below a predetermined threshold, it is an indication that there is a problem likely with one of the amplifiers, either 608 or 610, or a problem with the duplexer 604. Regardless of where the problem lies, the repeater would not be performing at an optimum level and would need to be

serviced. One advantage of this method is that the duplexer is included in the gain measurement, and therefore, any duplexer or filter failure would be detected as well.

[0045] In some embodiments, the duplexer 604 may be replaced by two antennas. In this configuration, the back-end, amplifier 608, is connected to either a filter 604a followed by an antenna 620 or to an antenna 620 directly. A second antenna 630 may either be connected directly or via a filter 604b to the front-end, amplifier 610. The antennas may be placed closely to each other with a known amount of isolation or leakage between them. Any of the back-end gain determination methods above may then be applied.

[0046] In another embodiment, as seen in FIG. 7, the gain of the repeater 700 could be measured by using a switchable artificial leakage path 702 between the output 704 and the input 706 of the repeater 700. The leakage path 702 allows the repeater 700 to switch in a known amount of attenuation 708, 710 between the two ports of the RF repeater 700. When the switch 712 is closed, completing leakage path 702 the gain through the leakage path 702 contains the chain of gain of amplifier/back-end 714, loss of duplexer 716, attenuations 708 and 710, loss of duplexer 718, and gain of amplifier/front-end 720 and filter 740. This leakage gain may be received at signal receiver 722 and compared against a threshold as with the embodiments above. The leakage gain represents the system gain since the gains of the amplifier paths 714 and 720 are known. The losses of the duplexers 716 and 718 are calibrated at the factory and the attenuations 708 and 710 may be set to known values. Therefore the signal receiver 722 may monitor the gain through the leakage path 702 when switch 712 is closed and

determine if there are problems with any of the amplifiers or duplexers that would require service to the repeater. As with the embodiments described above, noise measurements may be used to check for failures, or the system may use a signal generated by pilot signal generator 724 as set forth in more detail below. This configuration also assumes that all natural leakage paths, such as paths 730 and 732 are significantly lower than the leakage path 702.

[0047] In an alternate embodiment of a repeater 800 illustrated in FIG. 8, the transmit section gain from amplifier/back-end 802 may be monitored by the receive path signal receiver 804. The leakage 806 in the duplexer 808 between section 808a and 808b should be well calibrated to ensure accurate monitoring. The signal receiver 804 and amplifier/front-end 810 should also have bandwidths that are wide enough in their frequency range to partially or fully cover the frequency range of the transmit section through amplifier 802 as well. The amplifier/front-end 810 may also be tuned to the transmit frequencies for a short time to perform the gain measurement.

[0048] In some embodiments, the duplexer 808 may be replaced by two antennas. In this configuration, the back-end 802 may be connected to either a filter 808a followed by an antenna 820 or to an antenna 820 directly. A second antenna 830 may either be connected directly or via a filter 808b to front-end 810. The antennas are placed closely to each other with a known amount of isolation or leakage between them. Any of the back-end gain determination methods above may then be applied.

[0049] Alternatively, a pilot signal may be generated in the transmit section using pilot signal generator 812. In some embodiments, the pilot signal generator 812 may generate a signal 814 on a frequency that is close

to the receive band. The pilot signal frequency may also be outside of the transmit band. This may assist in suppressing the pilot signal at the antenna terminals, as it assists in preventing the pilot signal from being transmitted as high level interference in the wireless communication system. At the same time, the frequency may allow the receive amplifier/front-end 810 to receive the pilot signal without having to de-tune its synthesizer. The pilot signal does need to overcome a duplexer rejection (which is lowest at the cross-over point where the attenuation over frequency characteristics of filter 808b and filter 808a intersect) and the equivalent noise level of the receive amplifier/front-end 810.

[0050] Implementing digital signaling processing with digitized intermediate frequency signals in some embodiments would potentially allow the simple addition of this feature without any changes to the printed circuit boards. The pilot signal 814 may be generated in the digital section or an amplified signal of a repeated wireless standard could be used instead. The measurement receiver may also be implemented in the digital section as well. Adding the gain measurement capability to an existing digital RF repeater may only require a software update. The duplexer rejection could be either calibrated or, for an already deployed system, measured in a learning phase. After calibration or termination of learning phase, a variation from the expected number would represent a gain change in either amplifier/back-end 802 or amplifier/front-end 810. The gain of amplifier/front-end 810 may be determined from a noise measurement. The combination of both would then allow the measurement of the gain of amplifier/back-end 802.

Alarm Determination

[0051] By determining front-end and back-end gains independently of one another, at least four possible alarm conditions may exist. These include downlink front-end, downlink back-end, uplink front-end, and uplink back-end. Any failures determined from the gain measurements of the front-end and back-end of the uplink and downlink directions may then be sent upstream, either as a separate uplink message, or along other control or network lines that may be connected to the repeater. The location of the alarm may also prove useful for repair or replacement, if only portions of the repeater electronics need to be replaced or repaired.

[0052] As set forth above with respect to front-end gain determination, this is primarily accomplished in the existing power detectors 122, 124 in the digital processing components 102, 104 as seen in FIGS. 1A and 1B. As seen in flowchart 900 in FIG. 9A, the operational noise spectrum is obtained from the spectrum analyzer by one of the methods set forth above for the downlink direction (block 902). The noise level that was previously calibrated and stored is then retrieved (block 904). A comparison of the measured operational noise in the downlink direction is made with previously stored/calibrated noise values (block 906). If the downlink noise is not within a specified tolerance ("No" branch of decision block 908), then an alarm for the downlink front end is generated (block 910) and transmitted either through an uplink message or other communication with the repeater. If the noise is within tolerance ("Yes" branch of decision block 908), tests can begin again at block 902.

[0053] Similar operations occur for front-end gain determination for the uplink direction. As seen in flowchart 950 in FIG. 9B, the operational noise spectrum is obtained from the spectrum analyzer by one of the methods set forth above for the uplink direction (block 952). The noise level that was previously calibrated and stored is then retrieved (block 954). A comparison of the measured operational noise in the uplink direction is made with previously stored/calibrated noise values (block 956). If the uplink noise is not within a specified tolerance (“No” branch of decision block 958), then an alarm for the uplink front end is generated (block 960) and transmitted either through an uplink message or other communication with the repeater. If the noise is within tolerance (“Yes” branch of decision block 958), tests can begin again at block 952. Tests for either the uplink or downlink directions may be continuous or performed at specific intervals. For the embodiments where the antenna is switched off, tests may occur less frequently, for example once or twice during off-peak times.

[0054] As set forth above, back-end gain may be determined from the difference of the power measured at the output of the power amplifier and the known signal level at the input of the digital-to-analog converter (DAC). The process for the downlink direction may be seen in flowchart 1000 in FIG. 10A. Power levels at the input of the downlink DAC are computed (block 1002) from the digitized signal waveform in the digital section of the repeater. If the input to the DAC is below a specified threshold value (“No” branch of decision block 1004), then the gain determination and fault assessment are skipped, and the process may begin again at block 1002. If, however, the input to the DAC is above a specified threshold (“Yes” branch of decision block 1004),

then the power level is obtained from the downlink power amplifier (block 1006). The power ratio (or difference, if the power levels are measured in dB) is then calculated to determine the back-end gain (block 1008). The power ratio or difference may be determined using hardware, or hardware and software. For example, as seen in FIGS. 1A and 1B, one or more FPGAs 170, 172 may be utilized to determine the difference and perform the comparison. Similarly other special ASICs or other programmable chips may be used. Furthermore, the repeater 100 may be controlled by a controller (not shown) and the controller may determine the differences and other threshold comparisons. If the backend gain does not meet a specified tolerance ("No" branch of decision block 1010), then an alarm for the downlink back-end is generated (block 1012) and transmitted either through an uplink message or other communications with the repeater. If the back-end gain is within tolerance ("Yes" branch of decision block 1010), tests may begin again at block 1002.

[0055] Similarly for the uplink side, the process may be seen in flowchart 1050 in FIG. 10B. Power levels at the input of the uplink DAC are computed (block 1052) from the digitized signal waveform in the digital section of the repeater. If the input to the DAC is below a specified threshold value ("No" branch of decision block 1054), then the gain determination and fault assessment are skipped, and the process may begin again at block 1052. If, however, the input to the DAC is above a specified threshold ("Yes" branch of decision block 1054), then a power level is obtained from the uplink power amplifier (block 1056). The power ratio (or difference, if the power levels are measured in dB) is then calculated to determine the back-end gain

(block 1058). Similar to the downlink side, the power ratio or difference may be calculated using hardware, or hardware and software. If the backend gain does not meet a specified tolerance (“No” branch of decision block 1060), then an alarm for the uplink back-end is generated (block 1062) and transmitted either through an uplink message or other communications with the repeater. If the back-end gain is within tolerance (“Yes” branch of decision block 1060), tests may begin again at block 1052. Because there is no interruption to the signals when calculating and comparing back-end gains, these tests may be performed at any time. In some embodiments, determination of the front-end and back-end gains may be coordinated. In other embodiments, they may be checked independently of one another.

[0056] While the present invention has been illustrated by a description of one or more embodiments thereof and while these embodiments have been described in considerable detail, they are not intended to restrict or in any way limit the scope of the appended claims to such detail. The methodology that the embodiments of the invention cover applies not only to RF repeaters, but is also applicable to at least Distributed Antennal Systems (“DAS”) and remote radio heads. The methodology of the embodiments of the invention disclosed herein is generic enough to measure gain in all the additional above mentioned types of equipment as well as other related devices where gain may be measured. Additional advantages and modifications will readily appear to those skilled in the art. The invention in its broader aspects is therefore not limited to the specific details, representative apparatus and method, and illustrative examples shown and described.

Accordingly, departures may be made from such details without departing from the scope of the general inventive concept.

[0057] WHAT IS CLAIMED IS:

1. A method of monitoring at least one element of a wireless communication system, the method comprising:
 - obtaining an operational noise measurement by measuring a noise value outside of a bandwidth of a first device, but within a bandwidth of a second, subsequent device;
 - retrieving a stored parameter; and
 - comparing the measured operational noise measurement to the retrieved parameter.
2. The method of claim 1, further comprising:
 - in response to the operational noise measurement being outside of a specified tolerance with respect to the stored parameter, generating an alarm.
3. The method of claim 1, further comprising:
 - computing a power level at a point in a digital section of the wireless communication system;
 - measuring a power level at a point in a back end of the wireless communication system; and
 - calculating a gain of the wireless communication system using the power level from the measured back end power level and the computed power level in the digital section.
4. The method of claim 3, further comprising:
 - comparing the calculated gain to a predetermined range.

5. The method of claim 4, further comprising:
 - in response to the calculated gain deviating from the predetermined range, generating an alarm indicative of the gain deviation.
6. The method of claim 3, wherein at least one of the noise measurement and the gain calculation are performed in an uplink direction of the wireless communication system.
7. The method of claim 3, wherein at least one of the noise measurement and the gain calculation are performed in a downlink direction of the wireless communication system.
8. The method of claim 1, further comprising:
 - receiving a leakage signal of the wireless communications system at a signal receiver;
 - comparing the received leakage signal to a reference;
 - wherein the reference is a function of components of the wireless communication system in a leakage path of the leakage signal.
9. The method of claim 1, wherein the stored parameter includes a reference noise measurement.
10. The method of claim 1, wherein the stored parameter includes a gain and a reference signal.

11. The method of claim 1, wherein the first device is a duplexer.
12. The method of claim 1, wherein the second, subsequent device is a filter at a baseband frequency.
13. The method of claim 1, wherein the second, subsequent device is a filter at an intermediate frequency.
14. The method of claim 13, wherein the intermediate frequency filter is a SAW filter.
15. The method of claim 1, wherein the element of the wireless communication system is selected from a group consisting of: a repeater, a distributed antenna system, a remote radio head, and a RF amplifier.
16. A method of monitoring at least one element of a wireless communication system, the method comprising:
 - obtaining an operational noise measurement by:
 - tuning an input band of the element of the wireless communication system to shift the input band partially or completely outside of a bandwidth of a first device to create an open band; and
 - measuring an operational noise level in the open band;
 - retrieving a stored parameter;
 - comparing the measured operational noise level to the retrieved parameter.

17. The method of claim 16, wherein the input band is shifted to a lower frequency.
18. The method of claim 16, wherein the input band is shifted to a higher frequency.
19. The method of claim 16, further comprising:
 - repeating a portion of the input band that remains in the bandwidth of the first device during the shifting operation.
20. The method of claim 16, further comprising:
 - computing a power level at a point in a digital section of the wireless communication system;
 - measuring a power level at a point in a back end of the wireless communication system; and
 - calculating a gain of the wireless communication system using the power level from the measured back end power level and the computed power level in the digital section.
21. The method of claim 20, further comprising:
 - comparing the calculated gain to a predetermined range.
22. The method of claim 21, further comprising:
 - in response to the calculated gain deviating from the predetermined range, generating an alarm indicative of the gain deviation.

23. The method of claim 20, wherein at least one of the noise measurement and the gain calculation are performed in an uplink direction of the wireless communication system.
24. The method of claim 20, wherein at least one of the noise measurement and the gain calculation are performed in a downlink direction of the wireless communication system.
25. The method of claim 16, further comprising:
receiving a leakage signal of the wireless communications system at a signal receiver;
comparing the received leakage signal to a reference;
wherein the reference is a function of components of the wireless communication system in a leakage path of the leakage signal.
26. The method of claim 16, wherein the first device is selected from a group consisting of: a RF filter, a IF filter, and a digital filter.
27. The method of claim 16, wherein the stored parameter includes a reference noise measurement.
28. The method of claim 16, wherein the stored parameter includes a gain and a reference signal.

29. The method of claim 16, wherein the element of the wireless communications system is selected from a group consisting of: a repeater, a distributed antenna system, a remote radio head, and a RF amplifier.
30. The method of claim 16, further comprising:
in response to the operational noise measurement being outside of a specified tolerance with respect to the stored parameter, generating an alarm.
31. A method of monitoring at least one element of a wireless communication system in signal communication with an antenna, the method comprising:
obtaining an operational noise level by:
suppressing an input of the antenna;
measuring noise within a bandwidth of the element of the wireless communication network;
retrieving a stored parameter; and
comparing the measured operational noise level to the retrieved parameter.
32. The method of claim 31, further comprising:
in response to the comparison being outside of a predetermined tolerance, generating an alarm.
33. The method of claim 31, further comprising:
amplifying the operational noise prior to the noise measurement.

34. The method of claim 31, further comprising:
introducing a pilot signal from a signal generator prior to the noise measurement.
35. The method of claim 31, further comprising:
reconnecting the input to the antenna after measuring the noise.
36. The method of claim 31, further comprising:
computing a power level at a point in a digital section of the wireless communication system;
measuring a power level at a point in a back end of the wireless communication system; and
calculating a gain of the wireless communication system using the power level from the measured back end power level and the computed power level in the digital section.
37. The method of claim 36, further comprising:
comparing the calculated gain to a predetermined range.
38. The method of claim 37, further comprising:
in response to the calculated gain deviating from the predetermined range, generating an alarm indicative of the gain deviation.
39. The method of claim 36, wherein at least one of the noise measurement and the gain calculation are performed in an uplink direction of the wireless communication system.

40. The method of claim 36, wherein at least one of the noise measurement and the gain calculation are performed in a downlink direction of the wireless communication system.
41. The method of claim 31, further comprising:
receiving a leakage signal of the wireless communications system at a signal receiver;
comparing the received leakage signal to a reference;
wherein the reference is a function of components of the wireless communication system in a leakage path of the leakage signal.
42. The method of claim 31, wherein the wireless communication system is in a form selected from a group consisting of: a repeater, a distributed antenna system, and a remote radio head.
43. The method of claim 31, wherein the stored parameter includes a reference noise measurement.
44. The method of claim 31, wherein the stored parameter includes a gain and a reference signal.
45. A method of monitoring at least one element of a wireless communication system, the method comprising:
receiving a leakage signal of the element of the wireless communications system at a signal receiver; and
comparing the received leakage signal to a reference;

wherein the reference is a function of components of the wireless communication system in a leakage path of the leakage signal.

46. The method of claim 45, further comprising:
- measuring a signal level in the leakage path at an input to a back-end of the element of the wireless communications system;
 - measuring a portion of an output signal of the back-end that is received via a pre-determined leakage path to a first device or an over-the-air leakage path of a known value into a front-end of an opposite direction link of the element, and
 - determining a back-end gain by:
 - determining a ratio between a front-end output of the signal level and back-end input using a front-end gain and the pre-determined leakage between front-end and back-end,
 - wherein the front-end gain is determined by measuring an operational noise level in an open band.
47. The method of claim 45, further comprising:
- in response to the comparison being outside of a predetermined tolerance, generating an alarm.
48. The method of claim 45, wherein the leakage path comprises a switch, and wherein the leakage signal is received when the switch is closed.
49. The method of claim 48, wherein signals from natural leakage paths are significantly lower than the leakage signal from the switched leakage path.

50. The method of claim 45, further comprising:
introducing a pilot signal from a signal generator into the leakage path such that the received leakage signal contains at least a portion of the pilot signal.
51. The method of claim 50, wherein the pilot signal frequency is close to a receive band of the wireless communications system.
52. The method of claim 50, wherein the pilot signal frequency is outside of a transmit band of the wireless communications system.
53. The method of claim 45, further comprising:
obtaining an operational noise measurement by measuring a noise value outside of a bandwidth of a first device, but within a bandwidth of a second, subsequent device;
retrieving a stored parameter; and
comparing the measured operational noise measurement to the retrieved parameter.
54. The method of claim 45, further comprising:
obtaining an operational noise measurement by:
tuning an input band of the element of the wireless communication system to shift the input band partially or completely outside of a bandwidth of a first device to create an open band; and
measuring an operational noise level in the open band;

retrieving a stored parameter;

comparing the measured operational noise level to the retrieved parameter.

55. The method of claim 45, wherein the element of the wireless communication system is in signal communication with an antenna, the method further comprising:

obtaining an operational noise level by:

suppressing an input of the antenna;

measuring noise within a bandwidth of the element of the wireless communication network;

retrieving a stored parameter; and

comparing the measured operational noise level to the retrieved parameter.

56. The method of claim 45, wherein the element of the wireless communication system is in a form selected from a group consisting of: a repeater, a distributed antenna system, and a remote radio head.

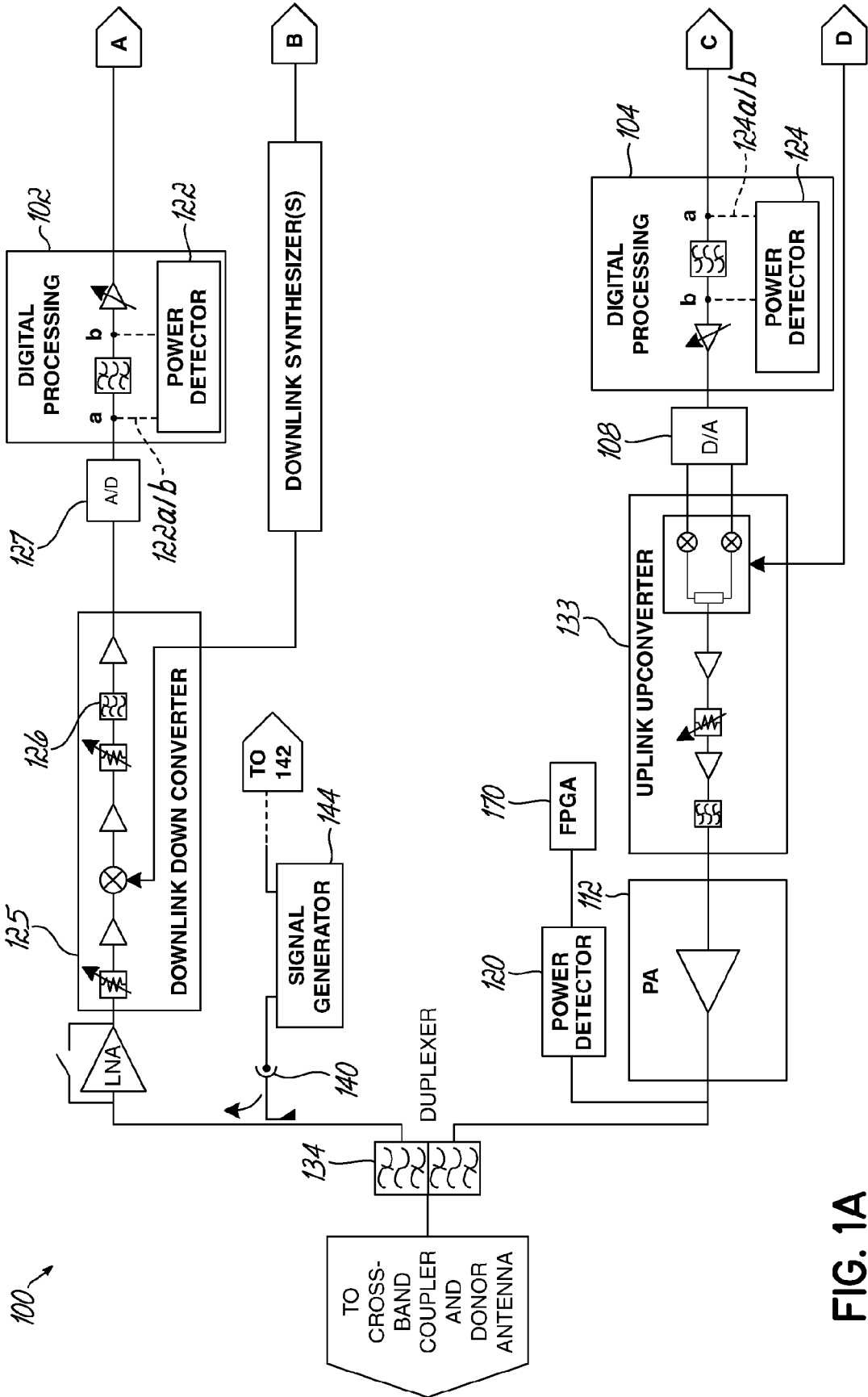

FIG. 1A

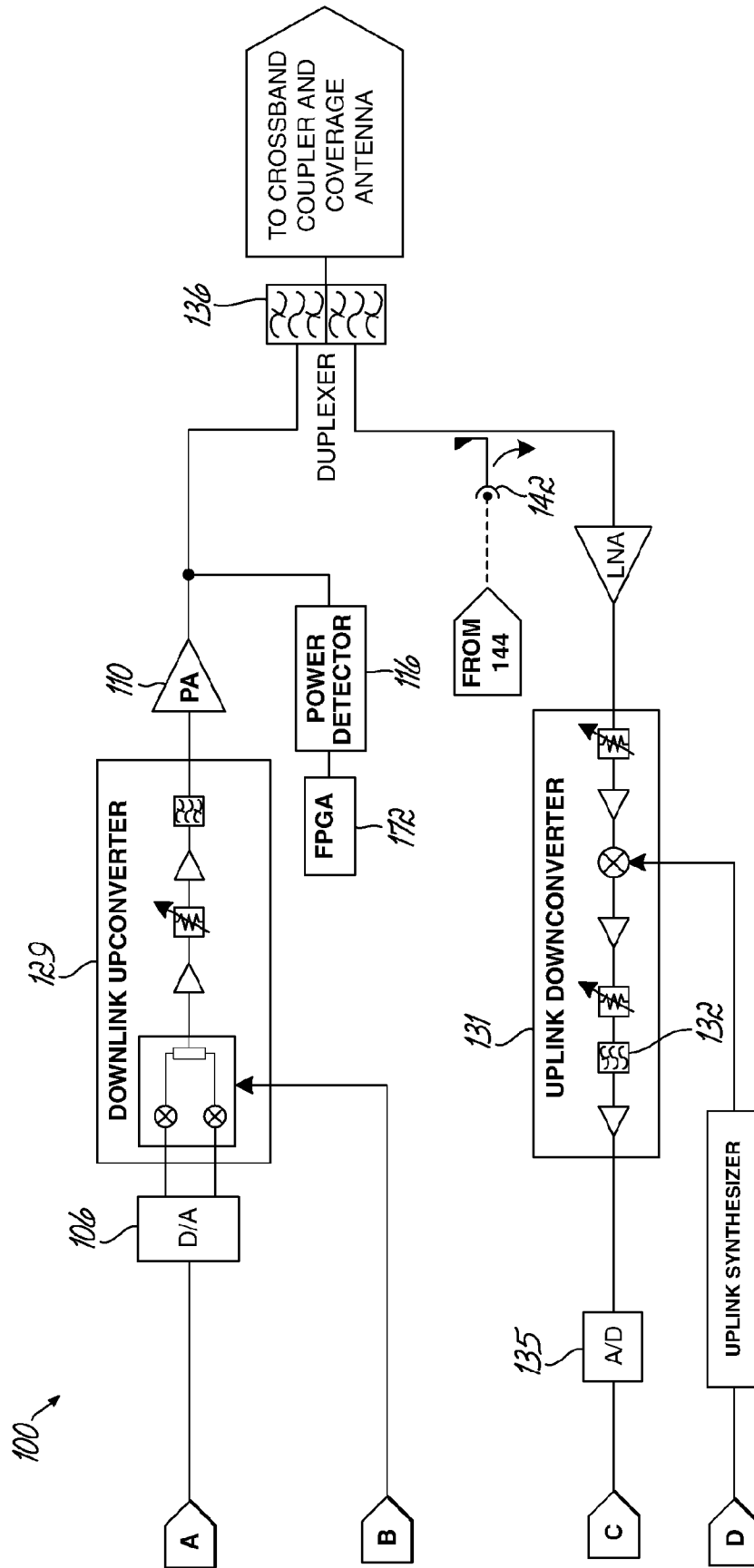

FIG. 1B

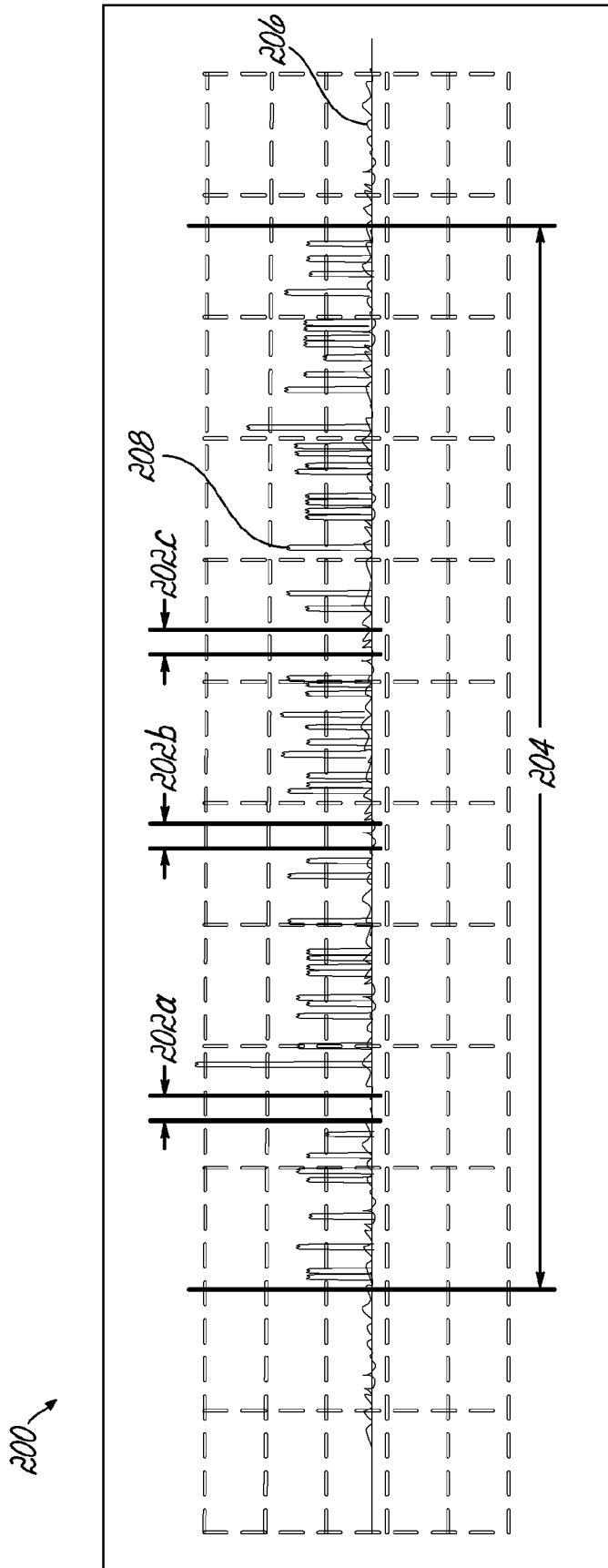

FIG. 2

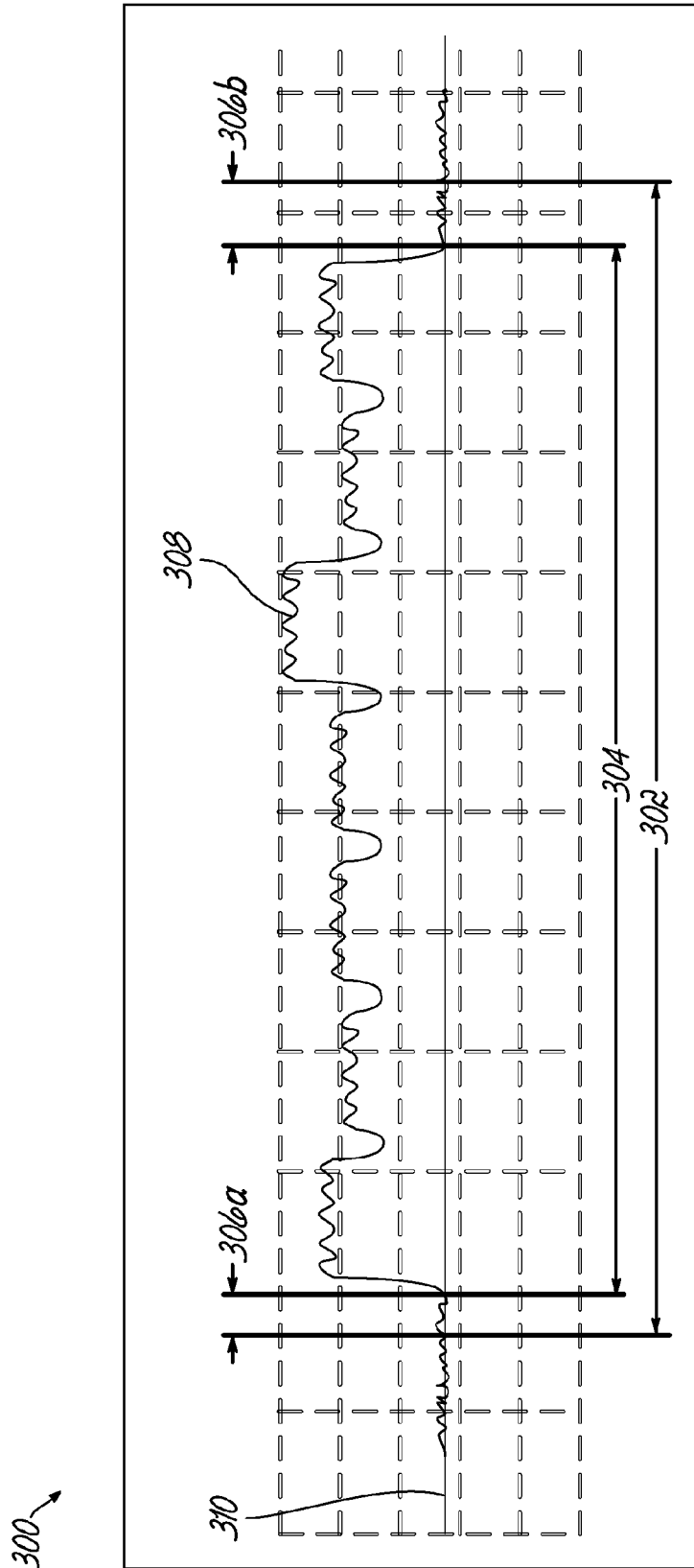

FIG. 3

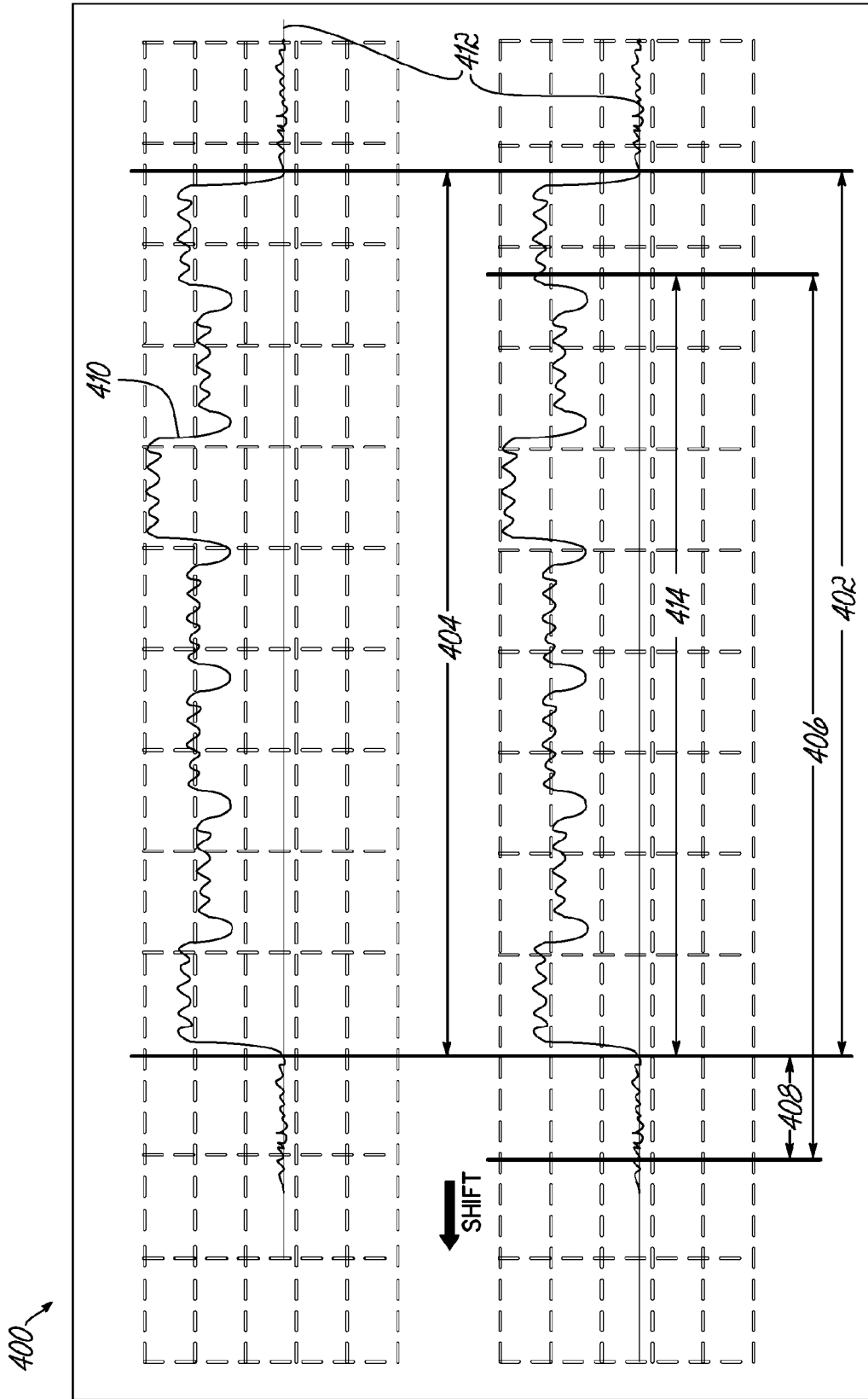

FIG. 4

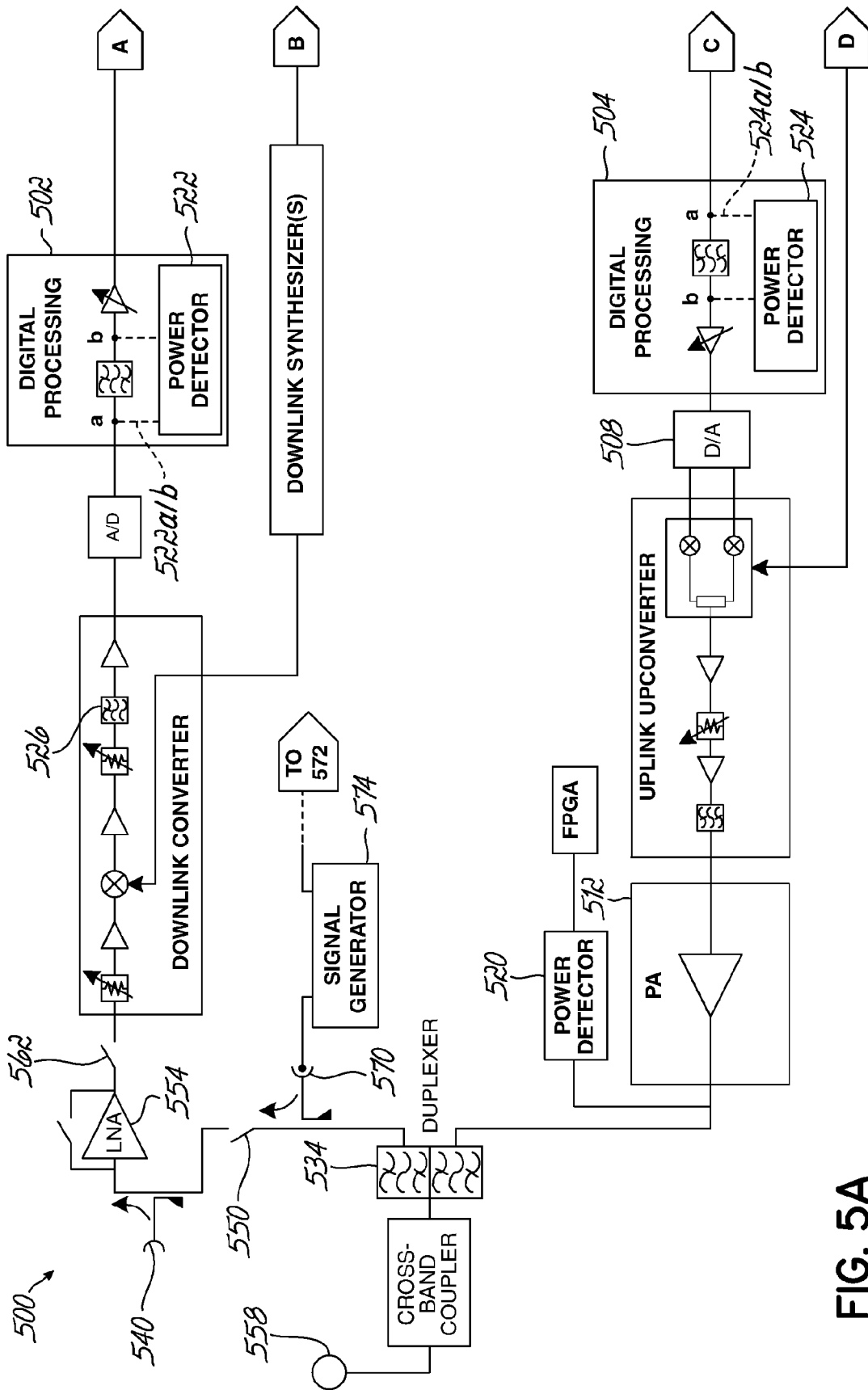

FIG. 5A

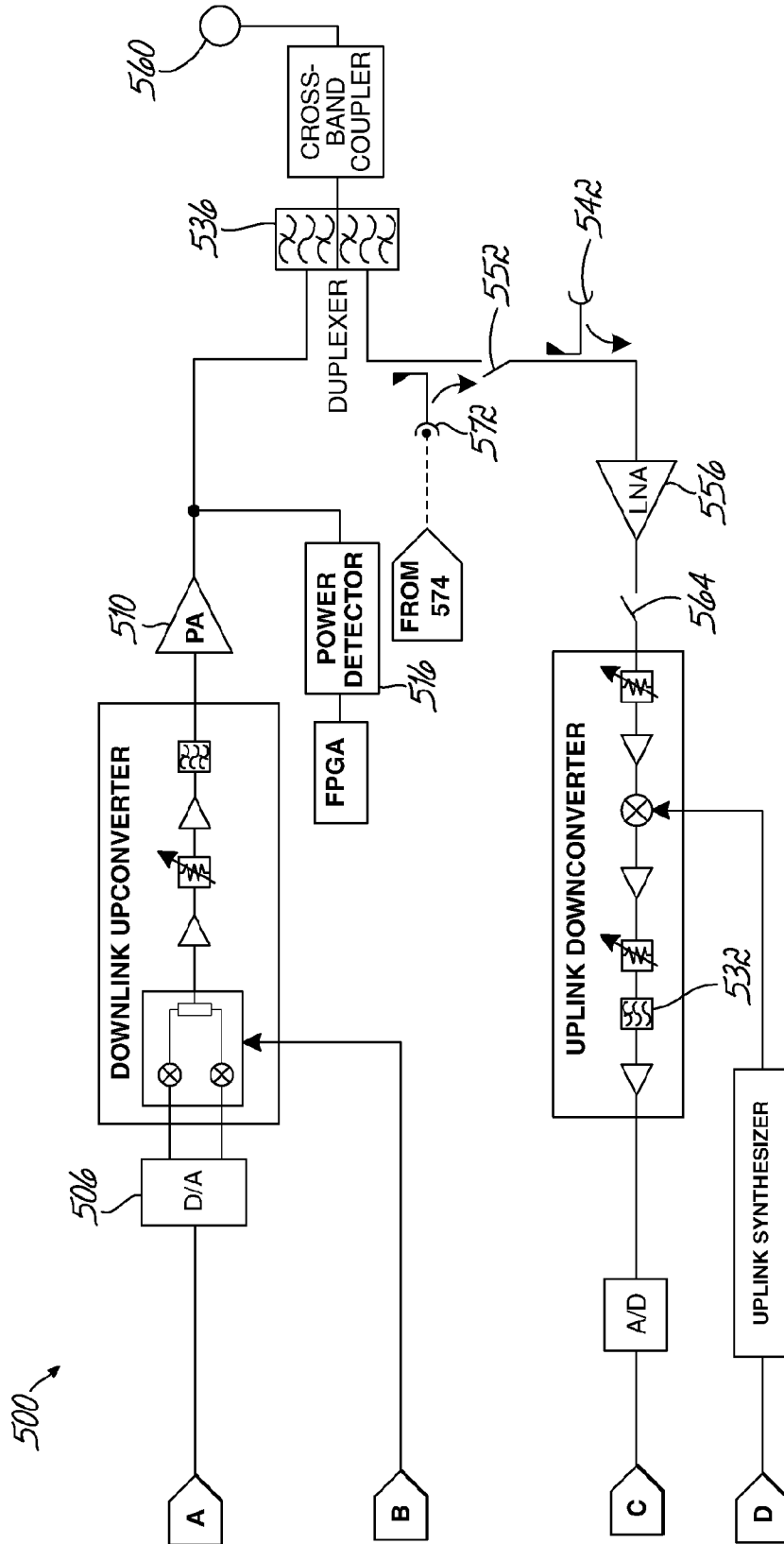

FIG. 5B

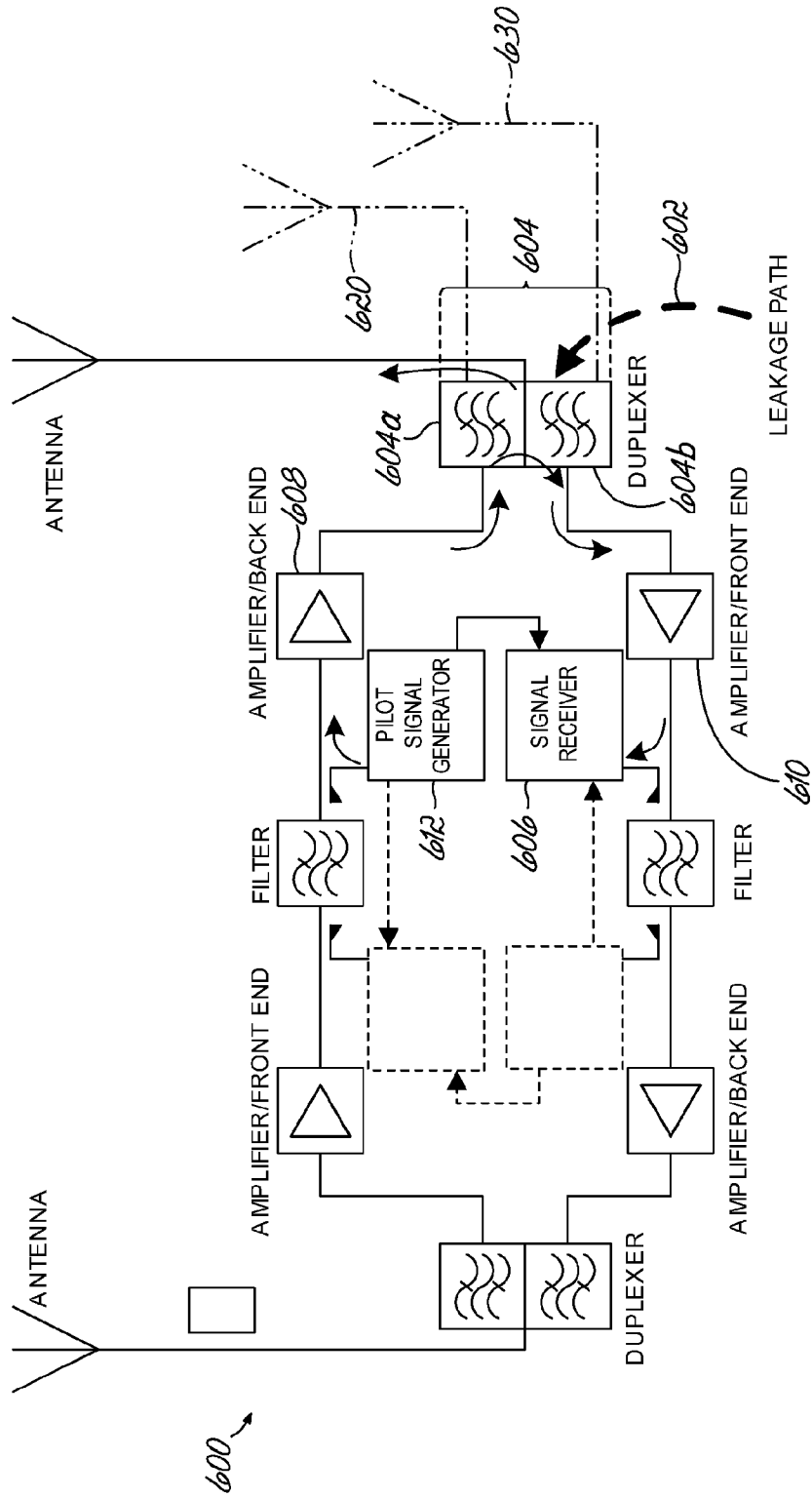

FIG. 6

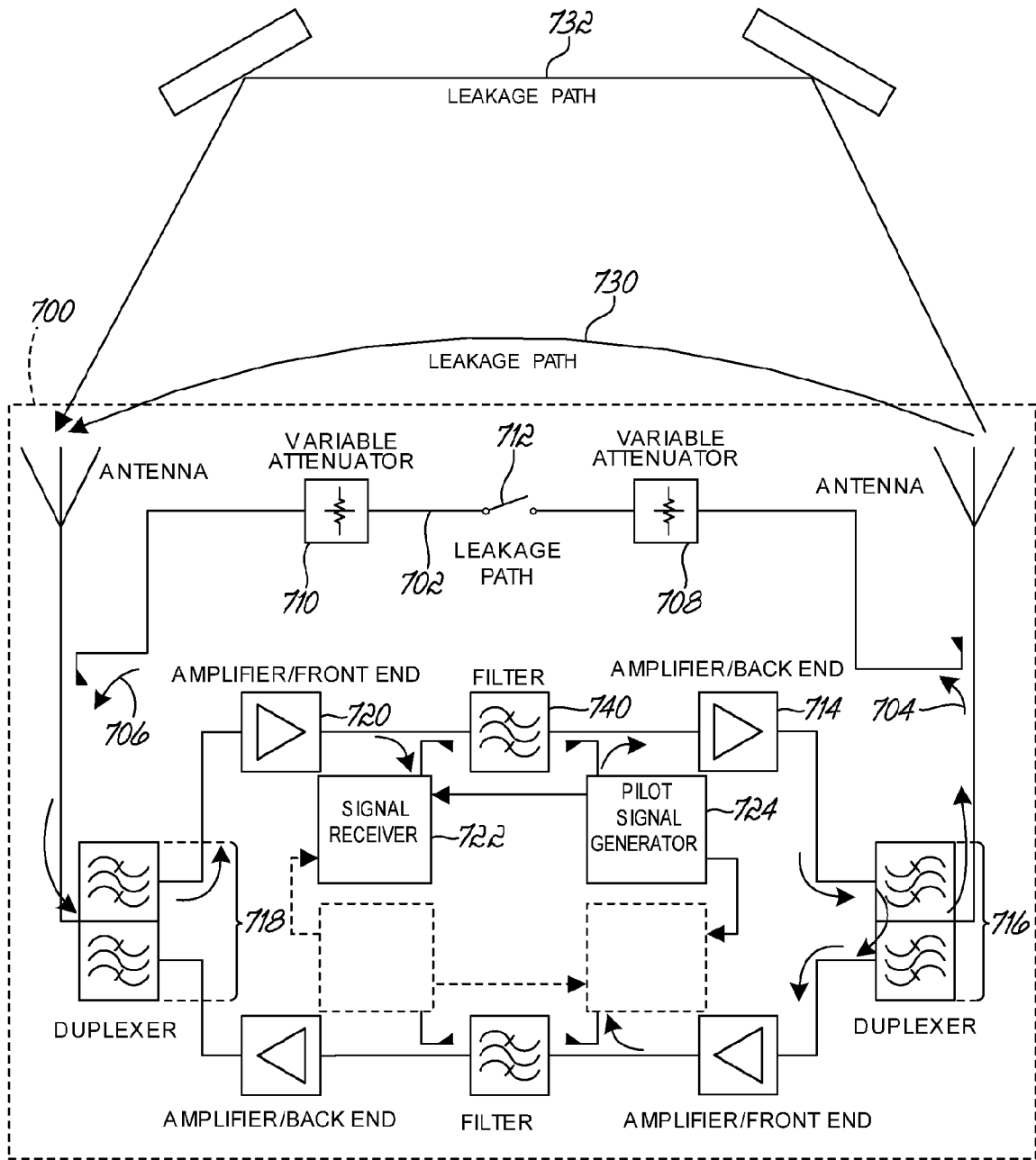

FIG. 7

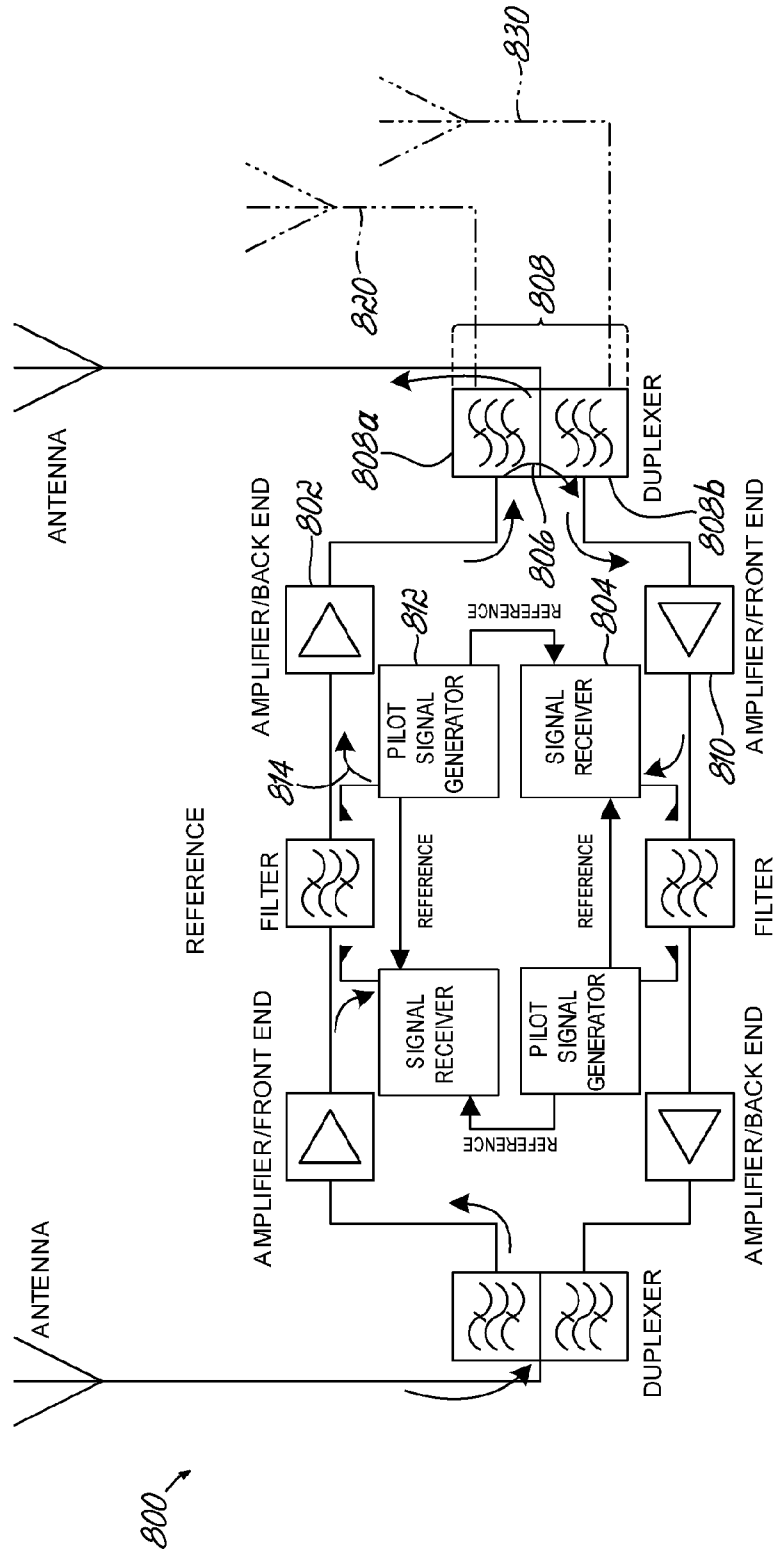

FIG. 8

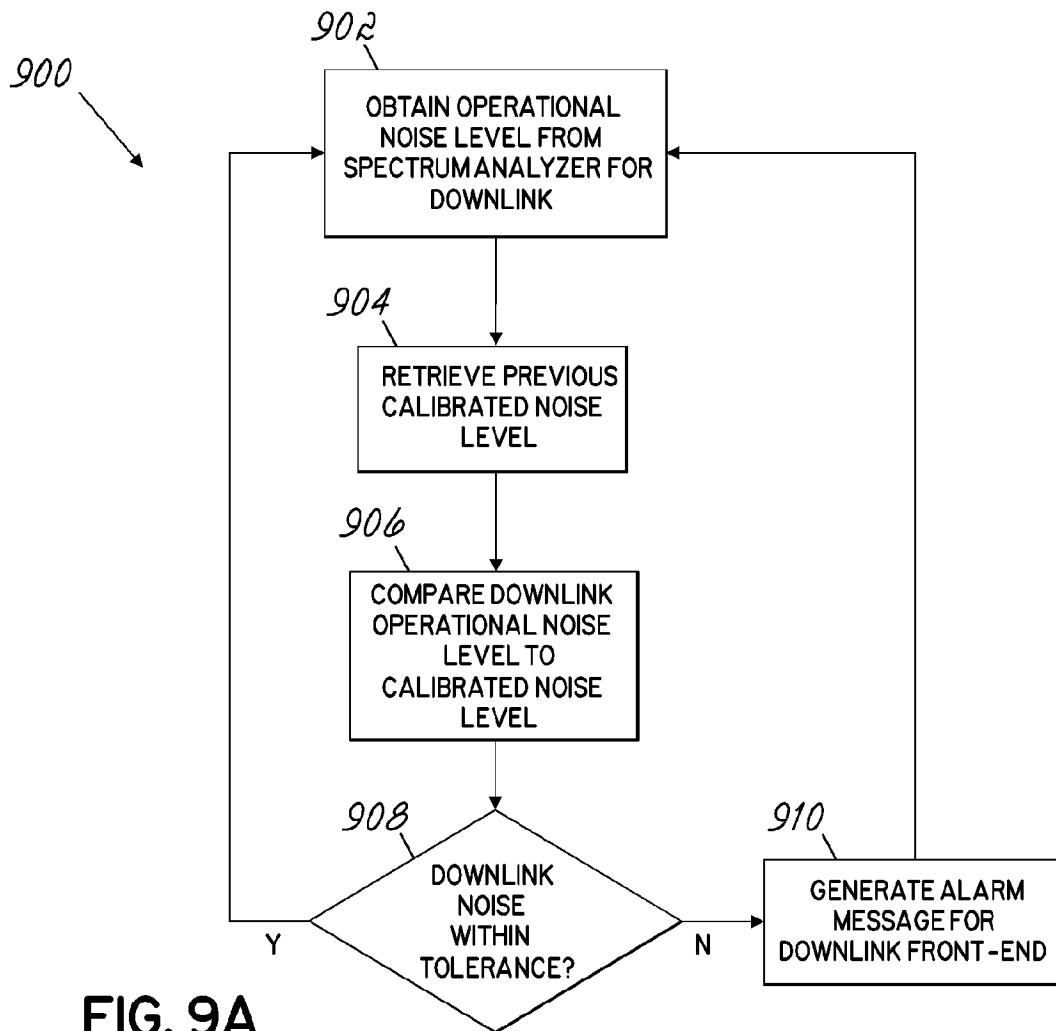

FIG. 9A

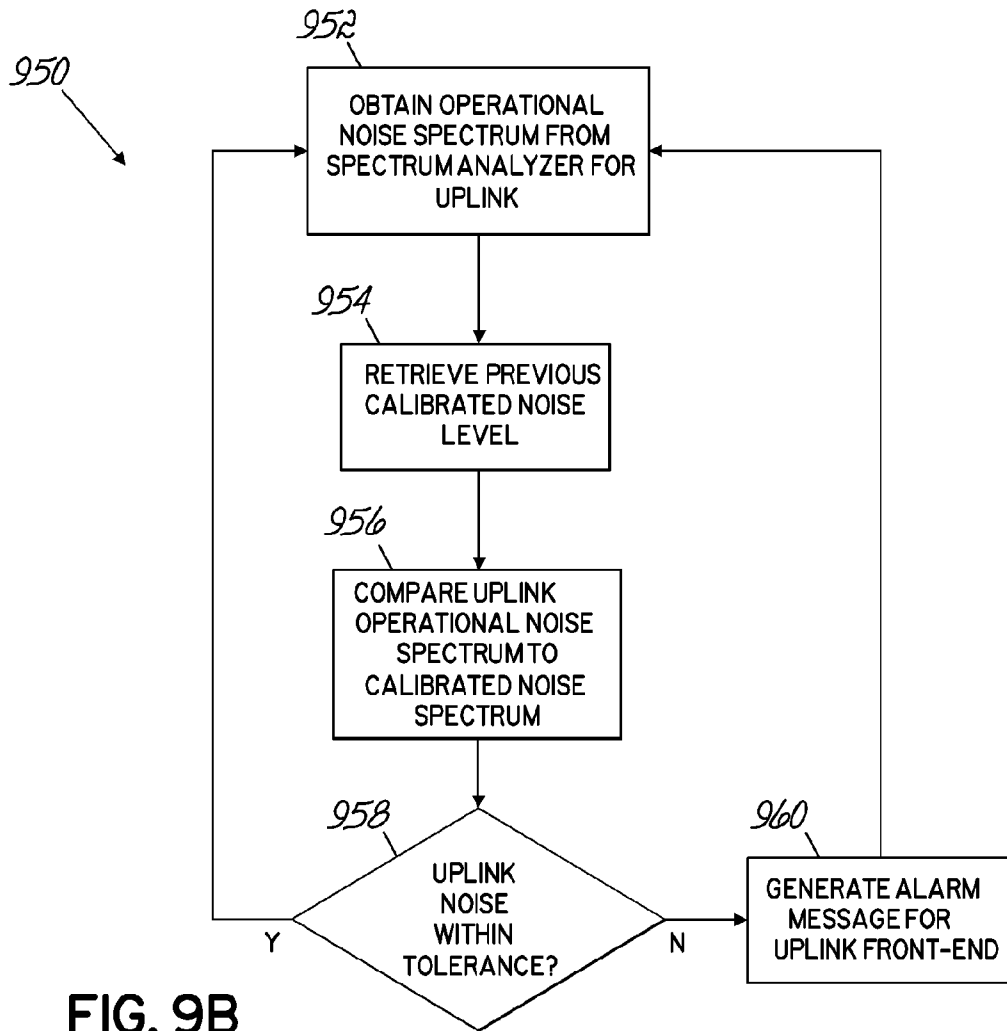

FIG. 9B

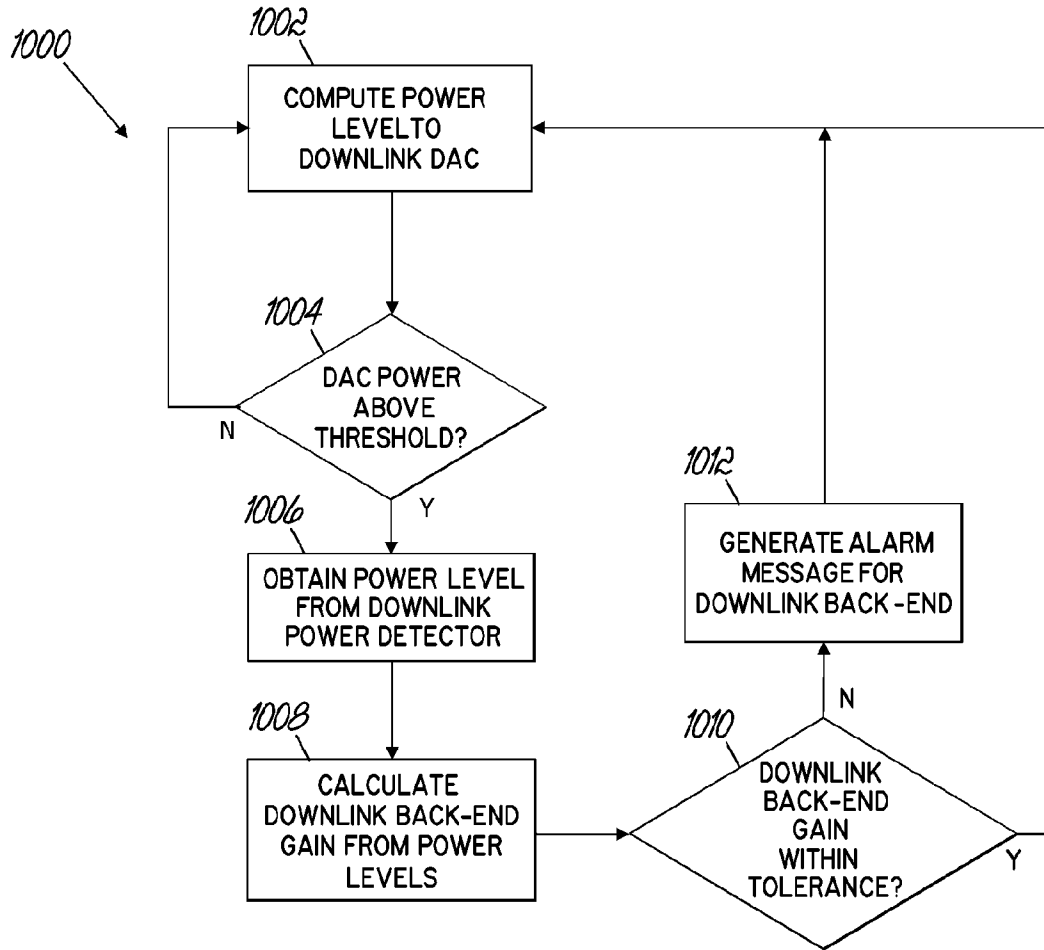

FIG. 10A

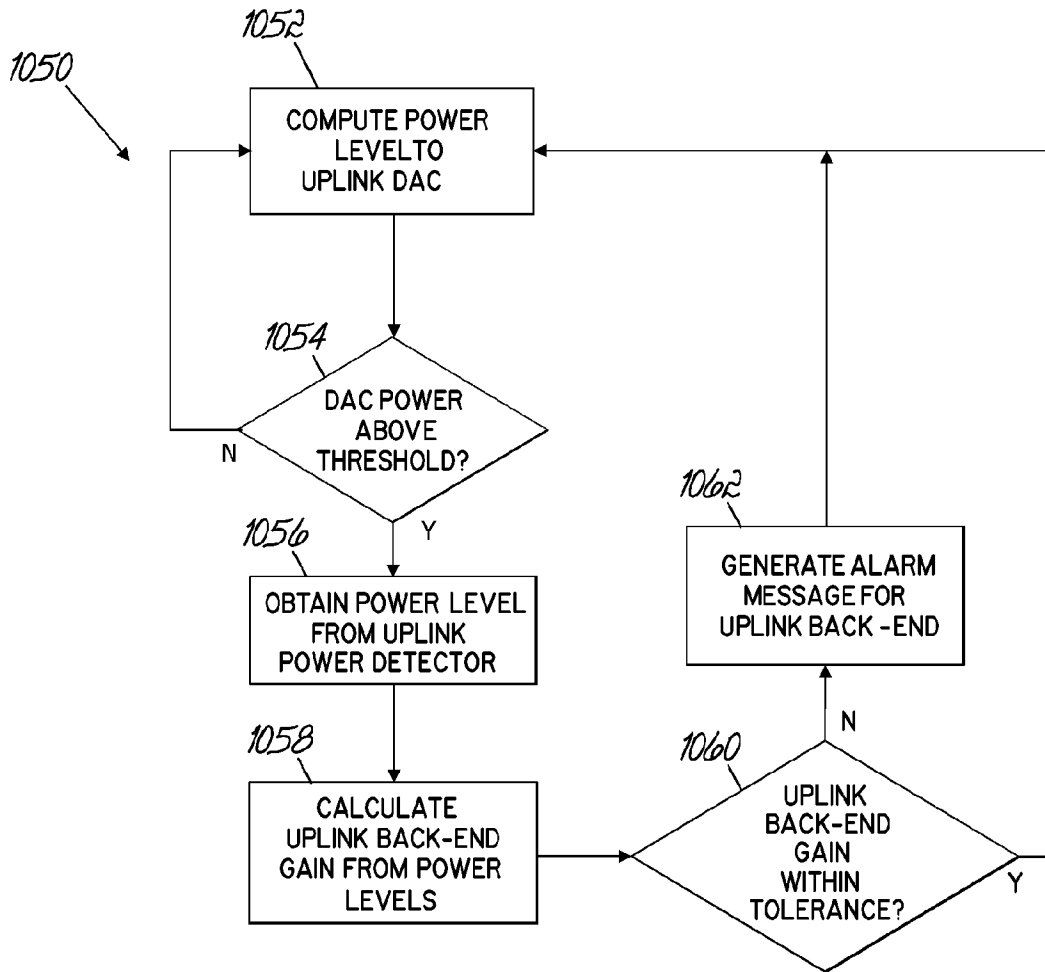

FIG. 10B

INTERNATIONAL SEARCH REPORT

International application No
PCT/US2011/024000

A. CLASSIFICATION OF SUBJECT MATTER
INV. H04B17/00
ADD.
According to International Patent Classification (IPC) or to both national classification and IPC

B. FIELDS SEARCHED
Minimum documentation searched (classification system followed by classification symbols)
H04B

Documentation searched other than minimum documentation to the extent that such documents are included in the fields searched

Electronic data base consulted during the international search (name of data base and, where practical, search terms used)
EPO-Internal, WPI Data

C. DOCUMENTS CONSIDERED TO BE RELEVANT

Category*	Citation of document, with indication, where appropriate, of the relevant passages	Relevant to claim No.
X	US 2009/298422 A1 (CONROY CORMAC S [US] ET AL) 3 December 2009 (2009-12-03)	1,3,4,6, 7,9-15, 31, 33-37, 39,40, 42-44
Y	abstract paragraphs [0027] - [0060] figures 2-5 ----- -/--	2,5,32, 38

Further documents are listed in the continuation of Box C.

See patent family annex.

* Special categories of cited documents :

- "A" document defining the general state of the art which is not considered to be of particular relevance
- "E" earlier document but published on or after the international filing date
- "L" document which may throw doubts on priority claim(s) or which is cited to establish the publication date of another citation or other special reason (as specified)
- "O" document referring to an oral disclosure, use, exhibition or other means
- "P" document published prior to the international filing date but later than the priority date claimed

- "T" later document published after the international filing date or priority date and not in conflict with the application but cited to understand the principle or theory underlying the invention
- "X" document of particular relevance; the claimed invention cannot be considered novel or cannot be considered to involve an inventive step when the document is taken alone
- "Y" document of particular relevance; the claimed invention cannot be considered to involve an inventive step when the document is combined with one or more other such documents, such combination being obvious to a person skilled in the art.
- "&" document member of the same patent family

Date of the actual completion of the international search
10 May 2011

Date of mailing of the international search report
11/08/2011

Name and mailing address of the ISA/
European Patent Office, P.B. 5818 Patentlaan 2
NL - 2280 HV Rijswijk
Tel. (+31-70) 340-2040,
Fax: (+31-70) 340-3016

Authorized officer
Helms, Jochen

INTERNATIONAL SEARCH REPORT

International application No
PCT/US2011/024000

C(Continuation). DOCUMENTS CONSIDERED TO BE RELEVANT		
Category*	Citation of document, with indication, where appropriate, of the relevant passages	Relevant to claim No.
X	US 7 447 490 B2 (KUO TIMOTHY C [US] ET AL) 4 November 2008 (2008-11-04)	1,3,4,6, 7,9-15, 31, 33-37, 39,40, 42-44
Y	abstract column 4, paragraph 45 - column 8, line 67 figures 2-6	2,5,32, 38
Y	----- US 2007/135056 A1 (KREMER MICHAEL [US] ET AL) 14 June 2007 (2007-06-14) paragraphs [0114], [130] - [0131], [151] claims 1, 8 -----	2,5,32, 38

INTERNATIONAL SEARCH REPORT

International application No.
PCT/US2011/024000

Box No. II Observations where certain claims were found unsearchable (Continuation of item 2 of first sheet)

This international search report has not been established in respect of certain claims under Article 17(2)(a) for the following reasons:

1. Claims Nos.:
because they relate to subject matter not required to be searched by this Authority, namely:

2. Claims Nos.:
because they relate to parts of the international application that do not comply with the prescribed requirements to such an extent that no meaningful international search can be carried out, specifically:

3. Claims Nos.:
because they are dependent claims and are not drafted in accordance with the second and third sentences of Rule 6.4(a).

Box No. III Observations where unity of invention is lacking (Continuation of item 3 of first sheet)

This International Searching Authority found multiple inventions in this international application, as follows:

see additional sheet

1. As all required additional search fees were timely paid by the applicant, this international search report covers all searchable claims.

2. As all searchable claims could be searched without effort justifying an additional fees, this Authority did not invite payment of additional fees.

3. As only some of the required additional search fees were timely paid by the applicant, this international search report covers only those claims for which fees were paid, specifically claims Nos.:

4. No required additional search fees were timely paid by the applicant. Consequently, this international search report is restricted to the invention first mentioned in the claims; it is covered by claims Nos.:

1-7, 9-15, 31-40, 42-44

Remark on Protest

- The additional search fees were accompanied by the applicant's protest and, where applicable, the payment of a protest fee.
- The additional search fees were accompanied by the applicant's protest but the applicable protest fee was not paid within the time limit specified in the invitation.
- No protest accompanied the payment of additional search fees.

FURTHER INFORMATION CONTINUED FROM PCT/ISA/ 210

This International Searching Authority found multiple (groups of) inventions in this international application, as follows:

1. claims: 1-7, 9-15, 31-40, 42-44

Measuring a noise value outside of a bandwidth of a first device, but within a bandwidth of a second, subsequent device.

1.1. claims: 31-40, 42-44

Suppressing an input of the antenna; measuring noise within a bandwidth of the element of the wireless communication network.

2. claims: 16-24, 26-30

Tuning an input band of the element of the wireless communication system to shift the input band partially or completely outside of a bandwidth of a first device to create an open band; and measuring an operational noise level in the open band.

3. claims: 8, 25, 41, 45-56

Receiving a leakage signal of the element of the wireless communications system at a signal receiver; and comparing the received leakage signal to a reference; wherein the reference is a function of components of the wireless communication system in a leakage path of the leakage signal.

INTERNATIONAL SEARCH REPORT

Information on patent family members

International application No

PCT/US2011/024000

Patent document cited in search report	Publication date	Patent family member(s)	Publication date	
US 2009298422	A1	03-12-2009	CN 101999216 A	30-03-2011
			EP 2289180 A1	02-03-2011
			KR 20110014684 A	11-02-2011
			WO 2009148879 A1	10-12-2009

US 7447490	B2	04-11-2008	CN 1881807 A	20-12-2006
			EP 1724953 A2	22-11-2006
			JP 2007013937 A	18-01-2007
			US 2006264192 A1	23-11-2006
			US 2008273637 A1	06-11-2008

US 2007135056	A1	14-06-2007	WO 2007070823 A2	21-06-2007
