

Jan. 26 , 1926.

1,570,680

A. A. KENT

IGNITION APPARATUS

Filed July 2, 1921

2 Sheets-Sheet 1

Fig. 1a.

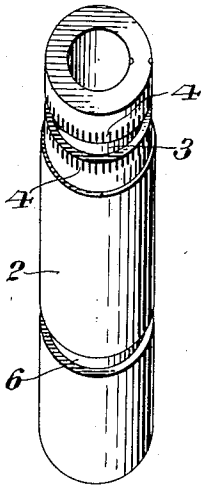

Fig. 1.

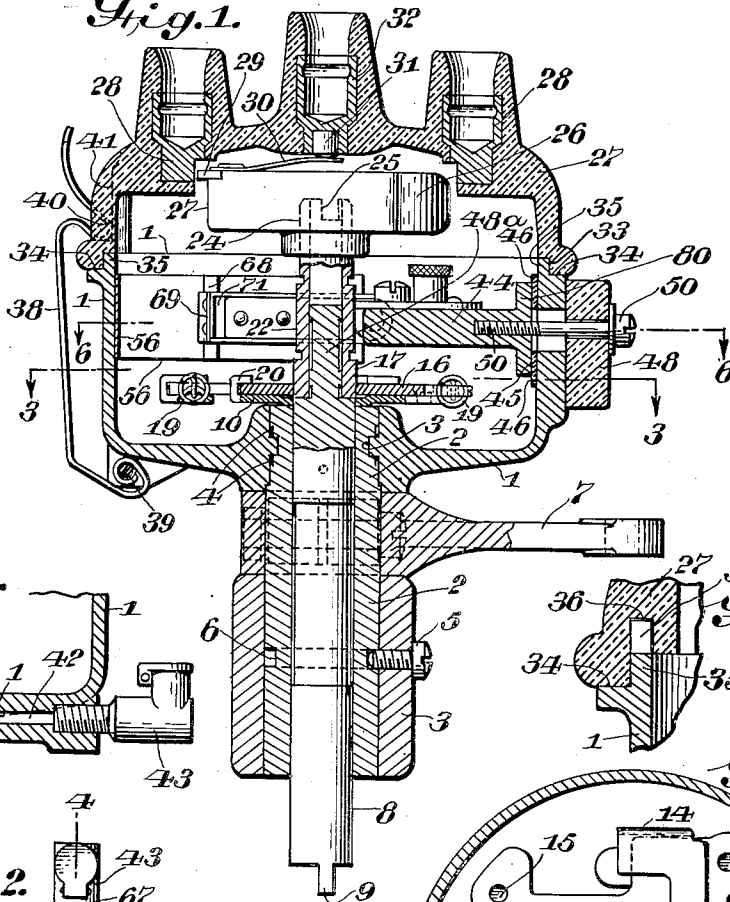

Fig. 4.

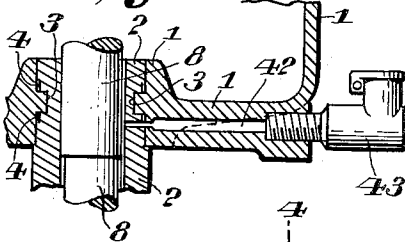

Fig. 5.

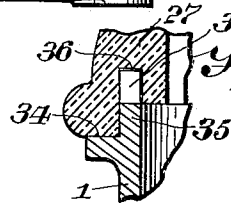

Fig. 2.

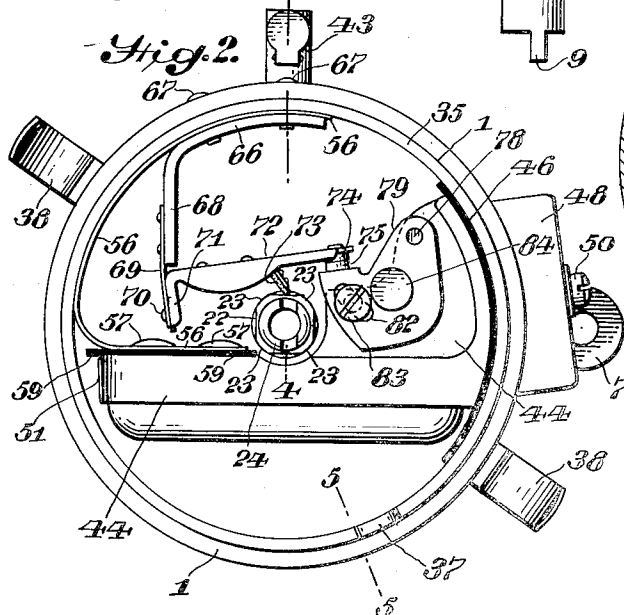
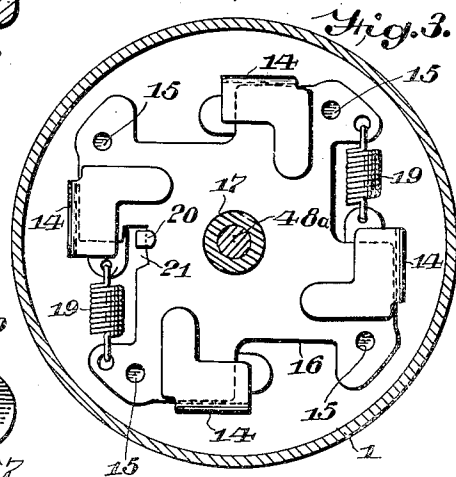

Fig. 3.



INVENTOR.

Arthur Atwater Kent

BY

Ormelius L. Ekret

his ATTORNEY.

Jan. 26 , 1926.

1,570,680

A. A. KENT

IGNITION APPARATUS

Filed July 2, 1921

2 Sheets-Sheet 2

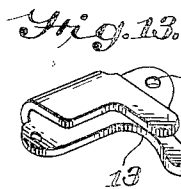
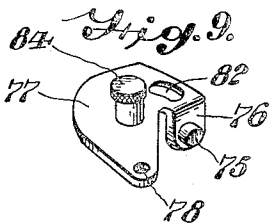
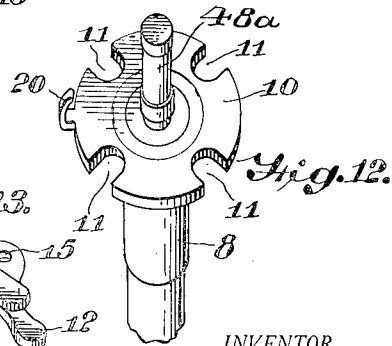
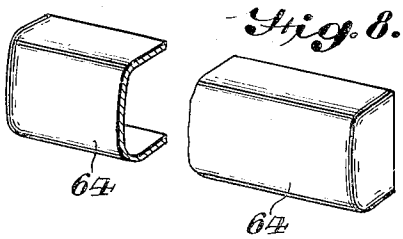
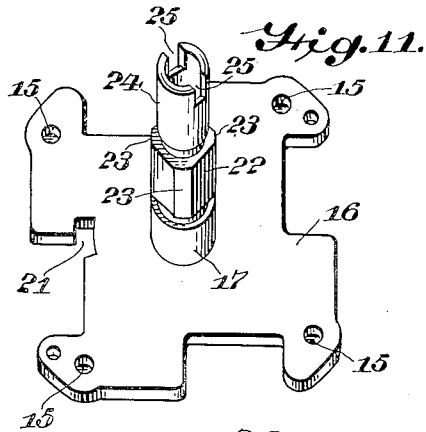
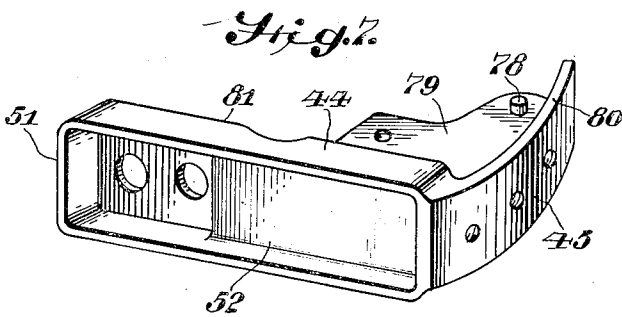
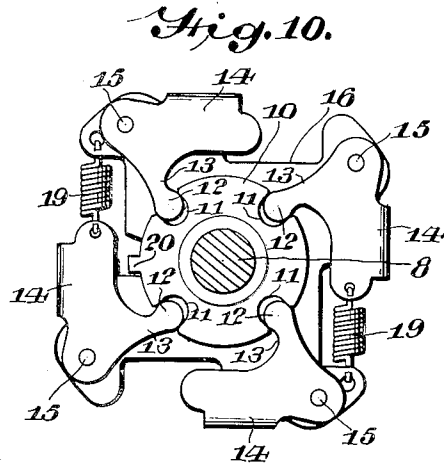
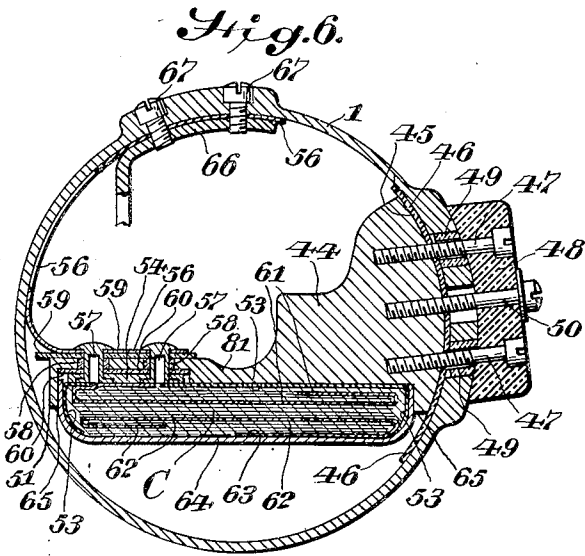

INVENTOR.  
Arthur Atwater Kent  
BY  
Cornelius S. Ehret  
his ATTORNEY.

# UNITED STATES PATENT OFFICE.

ARTHUR ATWATER KENT, OF ARDMORE, PENNSYLVANIA.

## IGNITION APPARATUS.

Application filed July 2, 1921. Serial No. 482,074.

*To all whom it may concern:*

Be it known that I, ARTHUR ATWATER KENT, a citizen of the United States, residing in Ardmore, county of Montgomery, and State of Pennsylvania, have invented certain new and useful Improvements in Ignition Apparatus, of which the following is a specification.

My invention relates to ignition apparatus for internal combustion engines such as employed upon motor vehicles and in other relations; and more particularly, it relates to the interrupter or ignition timing apparatus of an ignition system.

In accordance with my invention, I provide a casing upon a side wall of which is secured a transversely extending unit supporting one of the interrupter contacts and the condenser shunted across the interrupter contacts of which the movable contact is also preferably supported upon the side wall of said casing.

Further in accordance with my invention, the casing may, if desired, be a die casting having as an insert a hub or neck of different metal, as iron, forming a bearing for the timer shaft, and serving for other purposes.

My invention resides in features of structure and combination hereinafter described.

For an illustration of one of various forms my invention may take, reference is to be had to the accompanying drawings, in which:

Fig. 1 is a vertical sectional view, parts in elevation, of interrupter and distributor structure embodying my invention.

Fig. 1<sup>a</sup> is a perspective view of the hub insert member.

Fig. 2 is a plan view of the structure shown in Fig. 1 with the distributor cap removed.

Fig. 3 is a horizontal sectional view taken on the line 3—3 of Fig. 1.

Fig. 4 is a fragmentary sectional view, partly in elevation, on the line 4—4 of Fig. 2.

Fig. 5 is a fragmentary sectional view on the line 5—5 of Fig. 2.

Fig. 6 is a horizontal sectional view on the line 6—6 of Fig. 1.

Fig. 7 is a perspective view of the condenser holder unit.

Fig. 8 is a perspective view of the condenser cover.

Fig. 9 is a perspective view of the holder for the stationary interrupter contact.

Figs. 10 to 13 inclusive are views of the governor mechanism.

Referring to the drawings, 1 is a cylindrical metal casing, preferably a die casting of suitable alloy, in which is molded or cast a metallic insert 2, preferably of cast iron, having at its upper end the groove 3 adjacent which it is coarsely knurled or otherwise roughened, as indicated at 4, whereby the metal of the casing 1 makes snug and firm union with the insert 2. Hub 2 may, however, be integral with casing 1, which may be a die casting or of any other suitable material.

The casing and associated parts are supported by the insert 2, which has a bearing in the supporting member 3 carrying a screw 5 engaging in the groove 6 in the hub or neck 2. Clamped or otherwise secured to the hub 2 is a lever arm 7, to which may be attached any suitable means for rotating the casing 1 and attached parts for manually advancing or retarding the ignition.

Extending through and having a bearing within the hub 2, preferably directly upon the metal thereof without recourse to a bearing bushing, is a shaft 8 provided at its lower end with a lug 9 or any other suitable means for effecting a driving connection with the engine whose ignition the apparatus is to control, the shaft being driven in unvarying relation by and with respect to the crank shaft of the engine. Adjacent its upper end and within the casing 1 there is secured upon the shaft 8 the governor plate 10 having the notches 11 in which engage the rounded ends 12 on the arms 13 of the governor weights 14 pivoted at 15 upon the second governor plate 16 secured to the cam sleeve 17 which has a loose bearing upon the upper end of the shaft 8 at its portion 18 of reduced diameter. Springs 19 connect the free ends of the weights 18 with the plate 16. A lug 20 on the plate 10 extends through a notch or aperture 21 in the plate

16 and is bent over the plate 16, allowing rotation of the plate 16 with respect to plate 10 and limiting such rotation. The sleeve 17 carries or has formed thereon the cam 22 having as many points or surfaces 23 of maximum radius as there are cylinders of the engine. Integral with the cam sleeve 17 is the upper end portion 24 slotted at 25 to receive a rib within an aperture in the distributor block 26, of insulating material, in which is received the sleeve end 24.

Surmounting and closing the casing 1 is the distributor cap 27, preferably of molded insulating material, having molded therein the metallic inserts 28, equal in number to the number of cylinders in the engine, and adapted to receive flexible connectors leading to the spark plugs of the respective cylinders. These inserts are bared at their lower ends inside of the cap 27, and past their bared ends rotates the distributor terminal 29 carried by the distributor block 26 and electrically connected to the contact spring 30, which bears upon the high tension terminal 31 associated with the metallic insert 32 molded in the central boss on the cap 27, the insert 32 adapted to receive the end of a flexible cable or the like connecting to the high tension terminal of the induction coil whose primary circuit is controlled by the interrupter contacts hereinafter referred to.

The distributor cap has formed at its lower edge a circumferential groove 33 and abuts at 34 against the casing 1, which terminates at its upper end in a cylindrical tongue 35 engaging in the groove or channel 33.

As indicated in Figs. 2 and 5, the cap 2 is provided with a hole or recess 36 in alignment with the flange or end 35 of the casing 1 upon which is secured a pin 37 engaging in the aperture 36, whereby the cap 27 is prevented from rotation with respect to the casing 1.

A pair of spring hook members 38 is pivoted at 39 on opposite sides of the casing 1, the hook ends 40 of the members 38 engaging in recesses 41 in the cap 27, holding it snugly against the casing 1. Extending through the bottom wall of the casing 1 is an oil channel or hole 42 communicating at its inner end with the bore of the insert member 2 and at its outer end with the oil cup 43 threaded into the casing 1, as indicated in Fig. 4.

A metallic member or unit 44, preferably a die casting, has at its end 45 a surface concentric with the casing 1, and between the end 45 and the inner wall of the casing 1 is disposed a strip of insulating material 46 through which and the external block 48, of insulating material, extend the screws 47, 47 threaded into the member 44 and insulated from the casing 1 by the bushings 49. Simi-

larly, the screw 50 extends through the block 48 and is threaded into the unit 44, is insulated from the casing 1, and serves as a binding post for connecting to the unit 44 one terminal of the primary circuit of the induction coil. The unit 44 extends across the interior of the casing 1, spaced above the bottom thereof, with its remote end 51 unsupported or free of the casing 1. As indicated, the governor mechanism is preferably disposed between the unit 44 and the bottom of the casing 1.

The unit 44 has formed therein the recess or pocket 52 for receiving or holding the condenser C comprising alternate layers of foil or conducting material separated by dielectric or insulating material. In the example illustrated, the condenser is of the so-called rolled type comprising ribbons of tin foil or the like separated by ribbons of paper and covered by ribbons of paper and then rolled. At the back or bottom of the pocket 42 is disposed a sheet 53 of insulating material partially surrounding the condenser unit C and overlying the metallic plate 54 which, with the external metallic plate or ribbon 56, is held to the unit 44 by the metallic rivets or eyelets 57 passing through both metallic members 56 and 54 and insulated from the unit 44 by surrounding bushings 58. The ribbon or plate 56 is insulated from the member 54 by the sheet of insulating material 59, and the plate 54 is insulated from the interior of the unit 44 by the sheet of insulating material 60. Extending into the condenser unit C, transversely of the foil ribbons and contacting, respectively, with the different foil ribbons, are the metallic strips 61 and 62, of which the former is soldered or otherwise connected to the plate 54, at which sheet 53 has an aperture, and by the rivets or eyelets 57 with the external metallic plate or ribbon 56. The outer or free end 63 of the connector 62 is soldered or otherwise electrically connected to the inside of the metallic cover or cap 64, which is then forced into the pocket 52, as indicated in Fig. 6, and soldered preferably throughout its entire external joint at 65 to the metallic unit 44.

By the structure described, the condenser housing is formed of two members, one of them the cover 64, and one of the housing members is supported upon the side wall of the casing 1. Furthermore, by the structure described, the condenser unit is supported in mid air, so to speak, for it is supported by a member supported upon the side wall of the casing, and the condenser C is supported by that member above the bottom of the casing and in spaced relation from the side wall of the casing.

The condenser unit C is accordingly held or housed within the unit 44 and is preferably hermetically sealed in the pocket there-

in, one terminal of the condenser being in electrical connection through the connector 63 and the cover 64 with the metallic unit 44, while the other terminal is connected to the external metallic ribbon 56, which latter is clamped between the casing 1 and the metallic bracket 66 held to the casing 1 by the screws 67. The bracket 66 is, as indicated, secured to the side wall of the casing 1 and spaced between the top and bottom thereof. The bracket 66 has an inwardly extending end 68, to which is secured one end of the leaf spring 69, Fig. 2, whose remote end is secured at 70 to the transversely extending end 71 on the light rigid arm 72, to which is secured the shoe or other cam follower 73 adapted to engage and be actuated by the cam 22 to effect periodic engagement and separation of the movable interrupter contact 74, carried by the metallic arm 72, with and from the stationary interrupter contact 75 attached to the downwardly extending lug 76, Fig. 9, on the plate 77 pivoted at 78 to the unit 44, and particularly to the web portion 79 thereof between the arcuate flange 80 and the longitudinal portion 81 having the condenser pocket 52. The plate 77 is provided with an arcuate slot 82, whose center is the pivot 78, and through which extends the clamping screw 83 threaded into the web 79 of the unit 44. Attached to the plate 77 is the head or knob 84 by which the plate 77, and therefore the contact 75, may be rotated about the pivot 78 when the screw 83 is loosened, suitably to adjust the position of the stationary interrupter contact 75. When adjustment is effected, the screw 83 is tightened and holds the contact 75 fixedly in the adjusted position. The contact 75 and the pivot 78 are disposed relatively to each other, preferably as indicated, and the pivot 78 is positioned, preferably as indicated, practically in alignment with the arm 72 carrying the movable contact 74, whereby adjustment of the plate 77 and therefore contact 75 about the pivot 78 moves the contact 75 substantially in the direction of movement of the movable contact 74. The arm 72 is, in effect, pivoted adjacent its left end, and the plate 77, carrying the stationary contact 75, is pivoted at 78 on that side of the contacts 74, 75 opposite the point at which the arm 72 is pivoted, and the pivotal points and the contacts are preferably approximately or roughly in longitudinal alignment with each other. Furthermore, the contacts 74, 75 and the pivot 78 are on that side of the cam 22 opposite to that at which the arm 72 is pivoted. These relations of the parts have been found in practice to yield highly satisfactory operation in quickly effecting a sufficiently great separation of the contact 74 from contact 75, and in permitting suitable adjustment of the stationary contact 75. The

plate or member 77 is disposed within the casing 1 well above its bottom and below its upper edge, but nevertheless accessible from the upper end of the casing for adjustment, upon removal of the cap 27.

The contact 75 is in electrical communication with the unit 44, and therefore with one terminal of the condenser C and with the binding screw 50. The movable interrupter contact 74 is in electrical communication with the metallic casing 1, which in turn is grounded, as through the support 3, upon the frame of the motor vehicle or the engine, the arrangement indicated being suitable for an ignition system in which the primary circuit of the induction coil is grounded, as well understood in the art. The interrupter contact 74 is also in electrical communication through the metallic ribbon 56 with the remaining terminal of the condenser C. Accordingly, the condenser C is connected in shunt across the interrupter contacts 74 and 75 serving, as usual, to reduce the sparking thereat and to effect higher potential in the secondary of the induction coil.

With the casing 1 grounded as stated, the binding post 50 is connected to one terminal of the primary coil of the induction coil whose other terminal may connect to one terminal of a battery or suitable source of current, and the other terminal of such source is connected to ground.

Accordingly, when the shaft 8 is rotated, the contacts 74 and 75 periodically engage and separate, thereby periodically making and breaking the primary circuit of the induction coil to effect high potential impulses in the secondary of the induction coil, and those impulses are distributed, by the above mentioned distributor structure, to the spark plugs of the different cylinders of the engine in proper sequence.

Due to centrifugal force, the governor weights 14 tend to fly outwardly in opposition to springs 19, and in so moving outwardly cause rotation of the governor plate 16 and therefore of the cam 22 with respect to the shaft 8, such angular adjustment of the cam 22 advancing the ignition with increasing speed and retarding it with decreasing speed.

The cam follower shoe 73 may be made of any suitable material, as for example, fibre or the like. It is preferred, however, and it is a feature of my present invention, that the shoe 73 be made of fabric, preferably canvas, as in several layers, impregnated or saturated with bakelite, condensite or other condensation product or equivalent, and compressed into a sheet whose thickness corresponds with the thickness of the shoe 73, whose edge engages the cam.

A shoe of this material is impervious to moisture, somewhat resilient, and very

tough, with the result that it serves even better than indurated, vulcanized or other fibre as a cam-engaging shoe because of its aforementioned properties. In service, a shoe of this material, because of its unusual toughness, wears very slightly, if at all, with the result that adjustment of the interrupter contacts because of cam follower wear, is substantially entirely eliminated.

10 What I claim is:

1. Ignition controlling apparatus comprising a casing, a metallic condenser and contact-carrying unit secured to the inner side wall of said casing and projecting across said casing and spaced from the bottom thereof, an interrupter contact carried by said unit, and a condenser carried by said unit.

20 2. Ignition controlling apparatus comprising a casing, a metallic member secured to the inner side wall of said casing and projecting across said casing and spaced from the bottom thereof, an interrupter contact carried by said member, a co-acting movable interrupter contact supported upon the side wall of said casing, and a rotary cam within said casing controlling co-operation of said contacts.

30 3. Ignition controlling apparatus comprising a metallic casing, a metallic unit secured to the inner side wall of said casing, insulated therefrom and projecting across said casing and spaced from the bottom thereof, an interrupter contact carried by and electrically connected to said unit, a co-operating movable contact supported upon the side wall of said casing and electrically connected thereto, a condenser carried by said unit and having one of its terminals in electrical connection therewith, and a connection from the other terminal of said condenser to said movable contact.

40 4. Ignition controlling apparatus comprising a casing, a metallic unit secured at its one end to the side wall of said casing extending across said casing above the bottom thereof and terminating short of said casing, interrupter contacts insulated from each other and carried, respectively, by said unit and said casing, and a condenser carried by said metallic unit.

50 5. Ignition controlling apparatus comprising a casing, a metallic unit having an arcuate end at which it is secured to the side wall of said casing above the bottom thereof, said unit extending transversely of said casing and terminating short thereof, means insulating said unit from said casing, an interrupter contact carried by and electrically connected with said unit, a co-operating movable interrupter contact supported upon the side wall of said casing, said unit having a pocket, a condenser in said pocket, a connection from said casing through the wall of said pocket adjacent

the free end of said unit to one terminal of said condenser, a metallic cap covering said condenser and contacting with said unit, and a connection from the other terminal of said condenser to said cap.

6. Ignition controlling apparatus comprising a metallic casing, a metallic unit insulated therefrom and secured to the side wall of said casing above the bottom thereof and projecting transversely of said casing and terminating short thereof, an interrupter contact carried by and in electrical communication with said unit, a metallic bracket electrically connected with said casing and secured to the side wall thereof, a movable interrupter contact supported by said bracket, a condenser carried by said unit and having one terminal connected to said unit, and a connection from the other terminal of said condenser extending from the free end of said unit to said bracket.

7. Ignition controlling apparatus comprising a casing, a die cast unit having a condenser pocket and secured to the side wall of said casing above the bottom thereof and extending transversely of said casing and terminating short thereof, a condenser in said pocket, metallic plates insulated from said die casting disposed on the interior and the exterior thereof, means electrically connecting said plates and securing them in position, a connection from one terminal of said condenser to the inner of said plates, an interrupter contact within said casing, and a connection from said exterior plate to said interrupter contact.

8. Ignition controlling apparatus comprising a casing, a die cast unit having a condenser pocket and secured to the side wall of said casing above the bottom thereof and extending transversely of said casing and terminating short thereof, a condenser in said pocket, a metallic cap closing said pocket, a connection from one terminal of said condenser to said cap, said cap making electrical connection with said unit, an interrupter contact carried by said unit and electrically connected therewith, a co-operating interrupter contact within said casing, and a connection from the other terminal of said condenser with said last named contact.

9. Ignition controlling apparatus comprising a casing, a cam driving shaft extending into said casing, a centrifugal governor having a member secured to said shaft, a cam angularly adjustable with respect to said shaft, a second governor member secured to said cam, a metallic unit secured to the side wall of said casing extending transversely thereof, said governor disposed between said unit and the bottom of said casing, a condenser carried by said unit, an interrupter contact carried by said unit, and a co-acting movable interrupter contact sup-

70

75

80

85

90

95

100

105

110

115

120

125

130

ported upon the side wall of said casing and actuated by said cam.

10. Ignition controlling apparatus comprising a metallic casing, a cam driving shaft extending into said casing, a centrifugal governor having a member secured to said shaft, a cam angularly adjustable with respect to said shaft, a second governor member secured to said cam, a metallic unit secured to the side wall of said casing extending transversely thereof, said governor disposed between said unit and the bottom of said casing, a condenser carried by said unit, an interrupter contact carried by said unit, and a co-acting movable interrupter contact supported upon the side wall of said casing and actuated by said cam, said unit insulated from said casing, one terminal of said condenser connected through said unit to the interrupter contact carried thereby, said second interrupter contact electrically connected with said casing and with the other terminal of said condenser.

11. Ignition controlling apparatus comprising a metallic casing, a rotary cam therein, a movable interrupter contact controlled by said cam supported upon the side wall of said casing and electrically connected thereto, a metallic unit insulated from said casing secured to the side wall thereof and extending transversely thereof, a condenser carried by said unit and having one terminal connected to said interrupter contact, a second interrupter contact carried by said unit and connected therethrough with the other terminal of said condenser, an insulating member on the exterior of said casing, means extending therethrough and through said casing to secure said unit to said casing, and a circuit terminal communicating with said unit carried by said insulating member.

12. Ignition controlling apparatus comprising a casing, a metallic unit secured at one end to the side wall of said casing and extending transversely thereof with its other end free, a rotary cam within said casing, said unit extending past said cam adjacent thereto, a movable interrupter contact carried by said casing and controlled by said cam, a co-operating interrupter contact carried by said unit, and a condenser carried by said unit and having its terminals connected, respectively, to said interrupter contacts.

13. Ignition controlling apparatus comprising a metallic hub, a casing casting of different metal intimately united therewith, interrupter contacts within said casing, and a shaft extending through said hub bearing directly on the metal thereof and controlling co-action of said contacts.

14. Ignition controlling apparatus comprising a die cast casing, and a hub of different metal forming a bearing for a

cam shaft, said hub constituting an insert with which said casing is intimately united.

15. Ignition controlling apparatus comprising a die cast casing, a hub therefor of iron constituting an insert with which said casing is intimately united, and a cam shaft having a bearing in said hub.

16. Ignition controlling apparatus comprising a die cast casing of alloy, a cast iron hub therefor constituting an insert with which said casing is intimately united, and a cam shaft having a bearing in said hub directly on the metal thereof.

17. Ignition controlling apparatus comprising a die cast casing, a hub therefor of different metal, said casing and hub intimately united and one of them having a recess and the other a projection extending into said recess, and a cam shaft having a bearing in said hub.

18. Ignition controlling apparatus comprising a die cast casing, a hub of different metal therefor having a grooved and roughened end with which said casing is intimately united, and a cam shaft having a bearing in said hub.

19. Ignition controlling apparatus comprising a die cast casing, a hub of different metal therefor having a roughened end with which said casing is intimately united, and a cam shaft having a bearing in said hub.

20. Ignition controlling apparatus comprising a casing, a condenser-carrying unit detachably secured to the inner side wall of said casing and projecting across said casing and spaced from the bottom thereof, and a governor disposed in the space between said unit and said bottom of said casing.

21. Ignition controlling apparatus comprising a casing, a condenser- and contact-carrying unit secured to the inner side wall of said casing and projecting across said casing and spaced from the bottom thereof, and a governor disposed in the space between said unit and the bottom of said casing.

22. Ignition controlling apparatus comprising an interrupter contact movable in an arc, a co-acting stationary contact, a member supporting said stationary contact, and means for pivoting said member for adjustment of said fixed contact in an arc about a point disposed to one side of the line of relative movement of said contacts, the radii of said arcs having different lengths.

23. Ignition controlling apparatus comprising a pivoted arm, a movable interrupter contact carried thereby, a stationary co-acting interrupter contact, a member supporting said stationary contact, and a pivot for said member disposed on the side of said contacts opposite to the pivotal center of said arm.

24. Ignition controlling apparatus comprising a cam-actuated arm, an interrupter

- contact carried by said arm and movable in an arc, a co-acting stationary contact, at least one of said contacts having a substantially plane face, a member carrying said stationary contact, and a pivot for said member about which it is adjustable in an arc, said pivot disposed approximately in alignment with said face of said one of said contacts, and the radii of said arcs having different lengths.
25. Ignition controlling apparatus comprising a casing, a movable interrupter contact carried thereby, a member secured to the side wall of said casing and extending transversely thereof, a second member pivoted to said first named member, a stationary interrupter contact carried by said second named member, and means for clamping said second named member in fixed position.
26. As an element of ignition controlling apparatus, a metallic unit having an arcuate end and an integral transversely extending portion having a pocket adapted to receive a condenser.
27. As an element of ignition controlling apparatus, a metallic unit having an integral transversely extending portion having a pocket, a condenser in said pocket having one terminal connected to said unit, and a connector attached to the exterior of said unit, insulated therefrom and connected to the other terminal of said condenser within said pocket.
28. Ignition controlling apparatus comprising a casing, a hub thereon, a condenser unit secured on the side wall of said casing and spaced from the bottom thereof, co-acting interrupter contacts within said casing, a shaft having a bearing in said hub, a cam controlling said interrupter contacts, and a governor located between said condenser unit and the bottom of said casing and forming a connection between said shaft and said cam.
29. As an element of ignition controlling apparatus, a cam engaging shoe consisting of fabric permeated and stiffened with a condensation product.
30. As an element of ignition controlling apparatus, a cam engaging shoe consisting of superposed layers of fabric permeated and stiffened with a condensation product.
31. As an element of ignition controlling apparatus, a cam-following shoe consisting of a sheet of bakelized canvas whose edge engages the cam.
32. Ignition timing apparatus comprising a casing, interrupter contacts, a condenser shunting said interrupter contacts, a member attached to the side wall of said casing and extending transversely thereof and having a pocket extending transversely of said casing and adapted to receive said condenser, and a cup-shaped cover for said pocket having end walls adjacent the walls of said casing and joined to the bottom of said cup-shaped cover by portions falling within the intersections of the planes of said end walls and said bottom.
33. Ignition controlling apparatus comprising a casing open at its upper end, a support within said casing, a plate carried by said support above the bottom of said casing and below the upper edge thereof, said plate adjustable on said support, a movable interrupter contact, said plate having a downwardly extending lug, and a co-acting stationary contact on said lug.
34. Ignition controlling apparatus comprising a casing open at its upper end, a support within said casing, a plate carried by said support above the bottom of said casing and below the upper edge thereof, said plate adjustable on said support, a movable interrupter contact, said plate having a downwardly extending lug, a co-acting stationary contact on said lug, and an upwardly extending member on said plate for adjusting the same.
35. Ignition controlling apparatus comprising a casing open at its upper end, a cap on the upper end of said casing, a support within said casing, a plate carried by said support above the bottom of said casing and adjustable on said support in a plane beneath the joint between said casing and said cap, a movable interrupter contact, a downwardly extending lug on said plate, and a co-acting contact carried by said lug, said plate being accessible from the upper end of said casing for adjustment of said second named contact upon removal of said cap.
36. As an element of ignition controlling apparatus, a member consisting of a die casting having a pocket for holding a condenser, and a second member integral with said member and adapted to support timer contact structure.
37. A condenser unit comprising a die casting having a pocket, a condenser in said pocket, and a cup-shaped cover whose peripheral edges extend into said pocket.
38. In ignition controlling apparatus, the combination with a casing, of a condenser housing comprising two members attached to each other for enclosing a condenser, and a member secured to the side wall of said casing and supporting one of said housing members.
39. In ignition controlling apparatus, the combination with a casing, of a condenser housing comprising two members extending transversely of said casing and spaced from the bottom and side wall thereof, and a member secured to the side wall of said casing and supporting one of said housing members.
40. Ignition controlling apparatus comprising a longitudinally extending arm, a

contact carried thereby, a co-acting stationary contact, a support for said stationary contact, and means for pivoting said arm and said support on opposite sides of said contacts, said pivoting means and said contacts being disposed approximately in longitudinal alignment with each other.

5 41. As an element of ignition controlling apparatus, a metallic unit having an

arcuate end adapted for attachment to a curved casing surface, and an integral transversely extending portion having a pocket for receiving a condenser.

10 In testimony whereof I have hereunto affixed my signature this 23rd day of June, 15 1921.

ARTHUR ATWATER KENT.