



US00RE41498E

(19) **United States**
(12) **Reissued Patent**
Park et al.

(10) **Patent Number:** **US RE41,498 E**
(45) **Date of Reissued Patent:** **Aug. 10, 2010**

(54) **DEVICE AND METHODS FOR CHANNEL CODING AND RATE MATCHING IN A COMMUNICATION SYSTEM**

5,878,085 A * 3/1999 McCallister et al. 375/280
5,944,849 A * 8/1999 Sonetaka 714/786
6,081,921 A * 6/2000 Simanapalli 714/786
6,141,353 A * 10/2000 Li 370/465
6,166,667 A * 12/2000 Park 341/94

(75) Inventors: **Chang-Soo Park**, Seoul (KR);
Hyeon-Woo Lee, Suwon-si (KR)

FOREIGN PATENT DOCUMENTS

(73) Assignee: **Samsung Electronics Co., Ltd** (KR)

GB 2 296 165 6/1996
JP 05-055932 * 3/1993
JP 05-183448 * 7/1993
JP 2000-068862 * 3/2000

(21) Appl. No.: **10/967,119**

(22) Filed: **Oct. 15, 2004**

OTHER PUBLICATIONS

Related U.S. Patent Documents

Reissue of:

(64) Patent No.: **6,397,367**
Issued: **May 28, 2002**
Appl. No.: **09/326,891**
Filed: **Jun. 7, 1999**

Brissett et al., "Unequal Error Protection using Convolutional Codes", Proc. IEEE Southeastcon '96, pp. 242-245.*

(Continued)

(30) **Foreign Application Priority Data**

Jun. 5, 1998 (KR) 98-20990

Primary Examiner—Stephen M Baker

(74) *Attorney, Agent, or Firm*—TheFarrell Law Firm, LLP

(57) **ABSTRACT**

(51) **Int. Cl.**
H03M 13/27 (2006.01)
H03M 13/29 (2006.01)
H03M 13/35 (2006.01)
H03M 13/23 (2006.01)

A channel coding device is disclosed. In the device, a bit inserter inserts known bits in an input data bit stream at predetermined positions. A channel coder codes the bit-inserted data bit stream to generate coded symbols. A rate matcher matches a rate of the coded symbols to a given channel symbol rate. A channel interleaver interleaves the rate matched channel symbols. The rate matcher includes a puncturer for puncturing the inserted known bits included in the coded symbols when the coded symbol rate is higher than the given channel symbol rate. The rate matcher includes a repeater for repeating the coded symbols to match the coded symbol rate to the given channel symbol rate when the coded symbol rate is lower than the given channel symbol rate.

(52) **U.S. Cl.** **714/755**; 375/265; 714/786;
714/790; 714/792

(58) **Field of Classification Search** 714/786,
714/792, 755, 790; 375/265
See application file for complete search history.

(56) **References Cited**

U.S. PATENT DOCUMENTS

5,436,918 A * 7/1995 Kato et al. 714/795

26 Claims, 16 Drawing Sheets

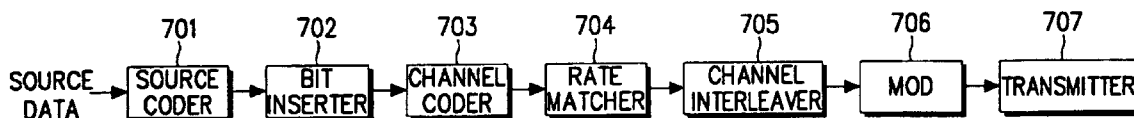

OTHER PUBLICATIONS

Frenger et al., "Rate Matching in Multichannel Systems using RCPC-Codes", IEEE 1997 Vehicular Technology Conference, pp.354-357.*

Answer, Affirmative Defenses, and Counterclaims of Samsung in *Ericsson Inc. v. Samsung Electronics Co., LTD.*, 2:06cv0063 (TJW), Eastern District of Texas, Marshall Division.

Reply to Counterclaims in *Ericsson Inc. v. Samsung Electronics Co., LTD.*, 2:06cv0063 (TJW), Eastern District of Texas, Marshall Division.

Order in *Ericsson Inc. v. Samsung Electronics Co., LTD.*, 2:06cv00063 (TJW), Eastern District of Texas, Marshall Division.

Divsalar et al., "Turbo Codes for PCS Applications", Proceedings of the IEEE International Conference on Communications ICC '95, Jun. 18-22, 1995.

Divsalar et al., "Turbo Codes for Deep-Space Communications", TDA Progress Report 42-120, Feb. 15, 1995.

Andersen, "Turbo Codes Extended with Outer BCH Code", Electronic Letters, Oct. 24, 1996.

Etaoud et al., "Adaptive Use of Error-Correcting Codes for Real-Time Communication in Wireless Networks", IEEE INFOCOM '98, Mar. 2-Apr. 1998.

ETSI, TR 101 146 V3.0.0., "Universal Mobile Telecommunications System (UMTS); UMTS Terrestrial Radio Access (UTRA); Concept Evaluation (UMTS 30.06 version 3.0.0.0)" Dec. 1997.

* cited by examiner

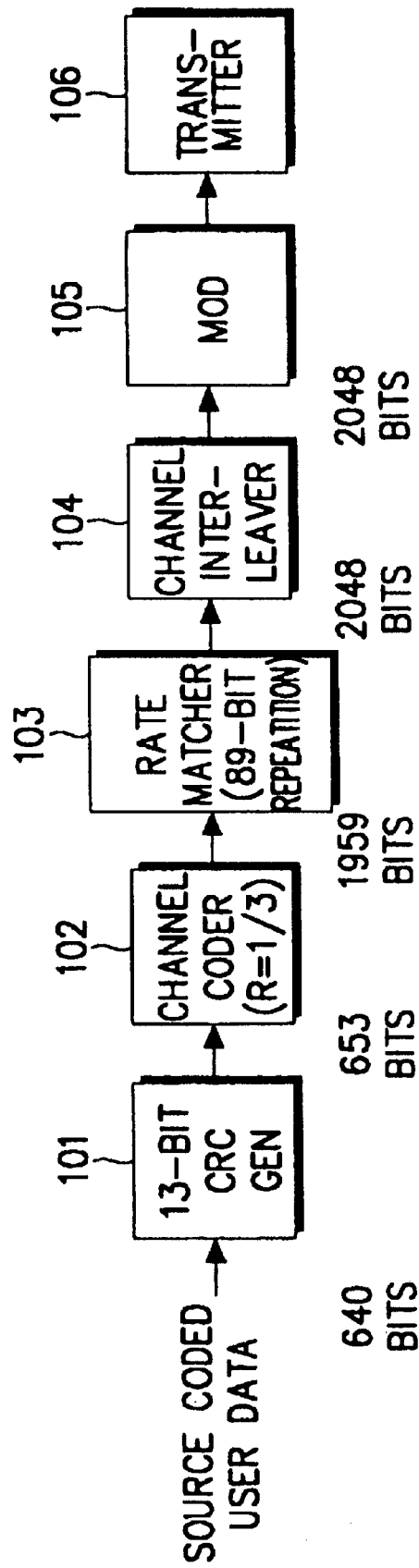

FIG. 1
PRIOR ART

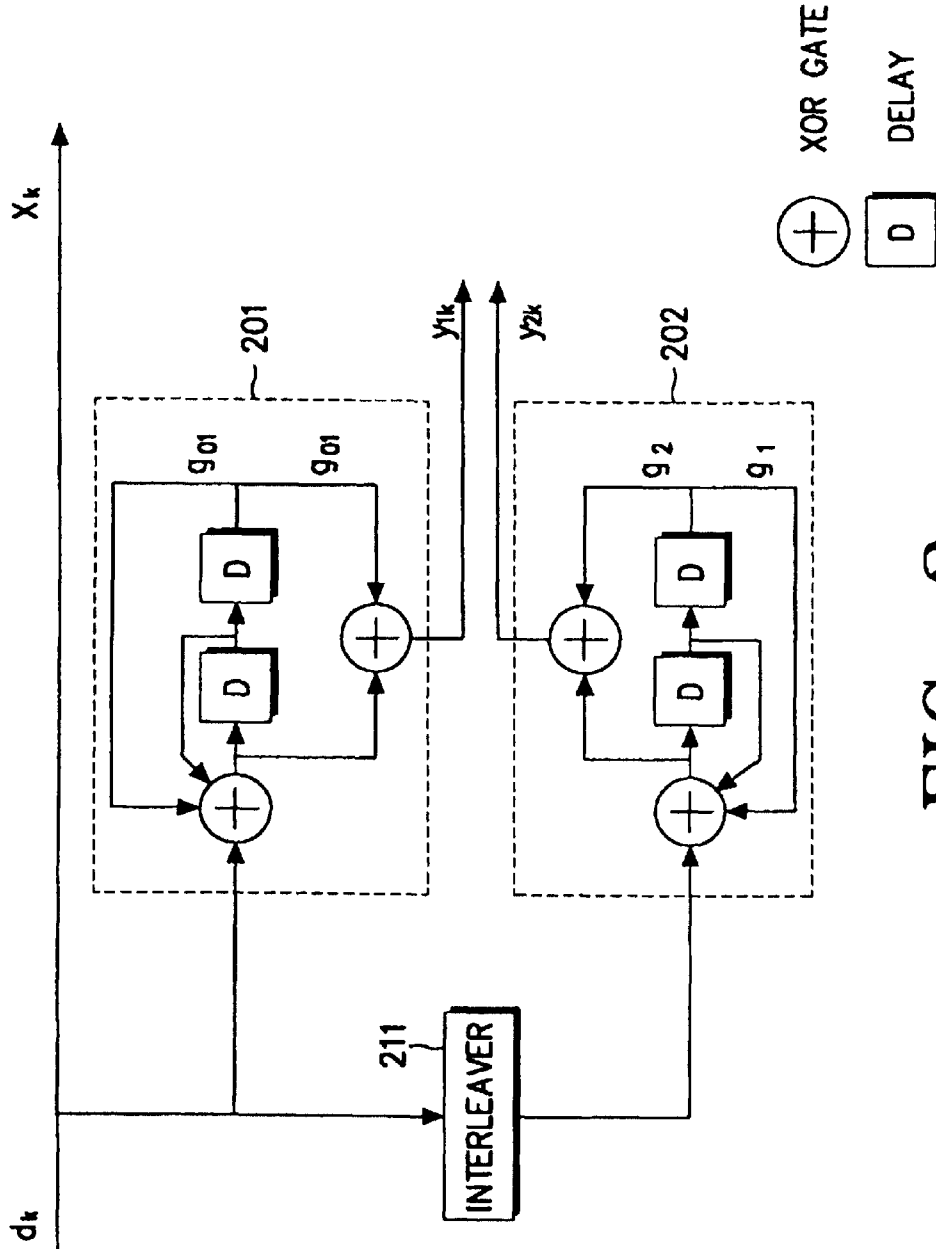

FIG. 2
PRIOR ART

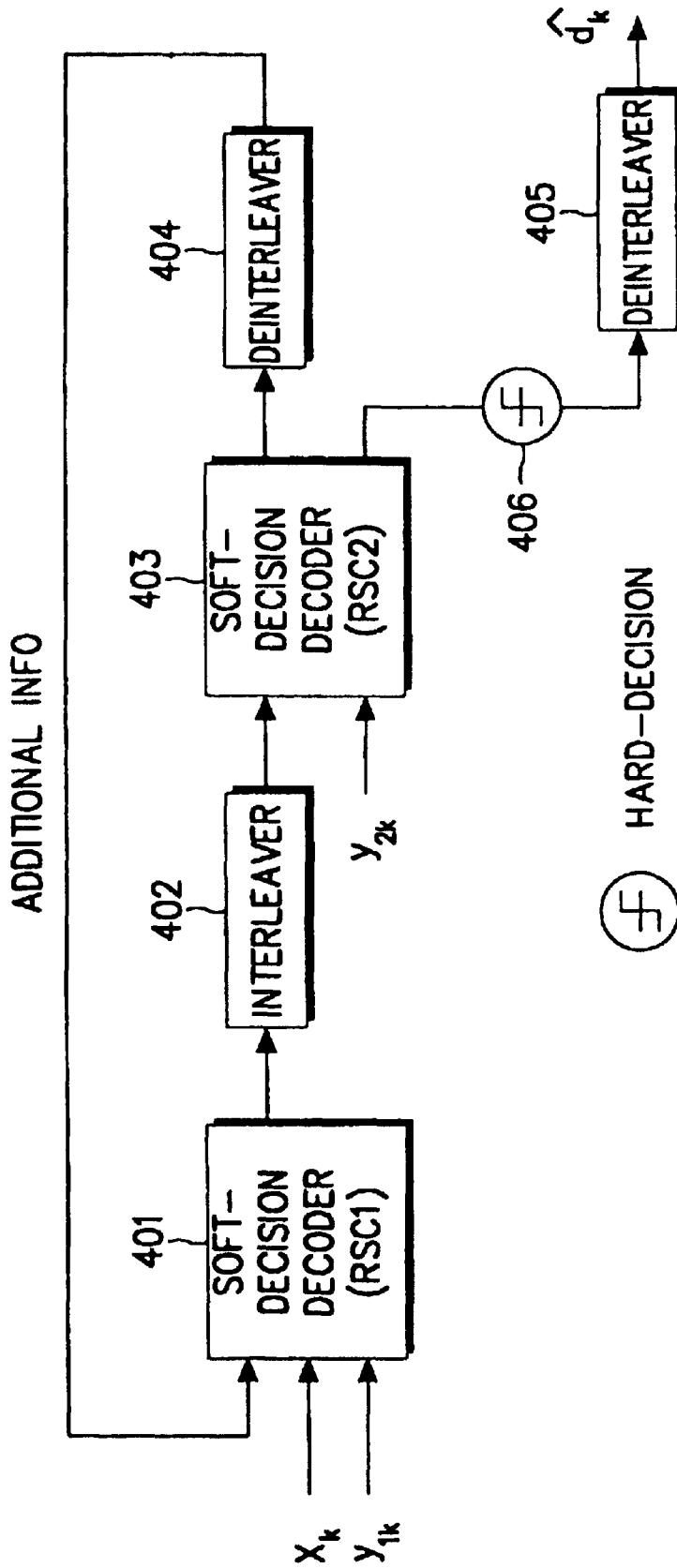

FIG. 4
PRIOR ART

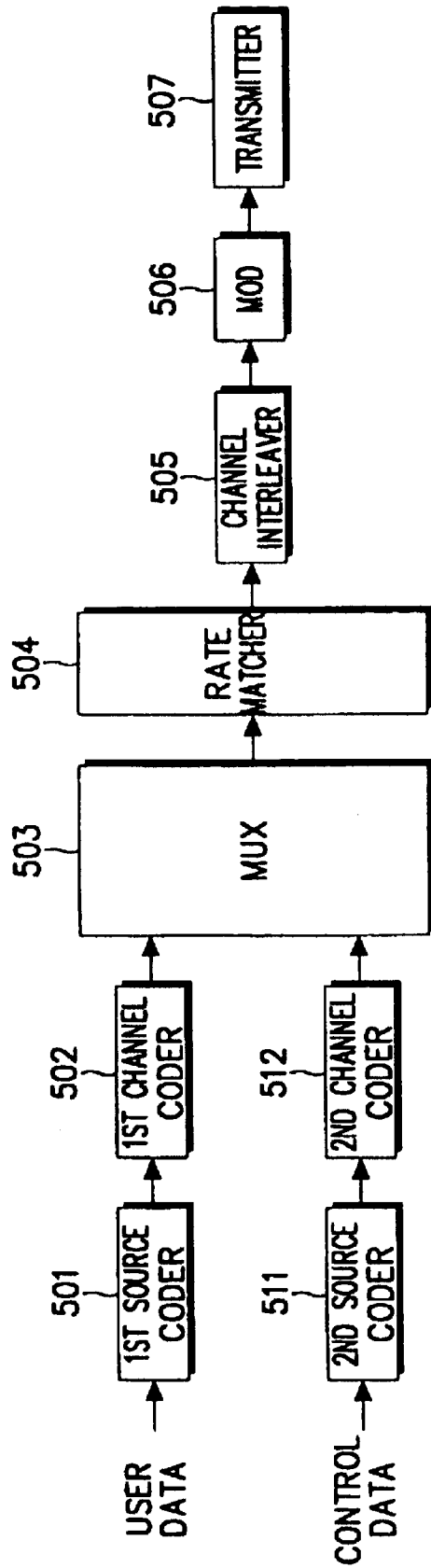

FIG. 5
PRIOR ART

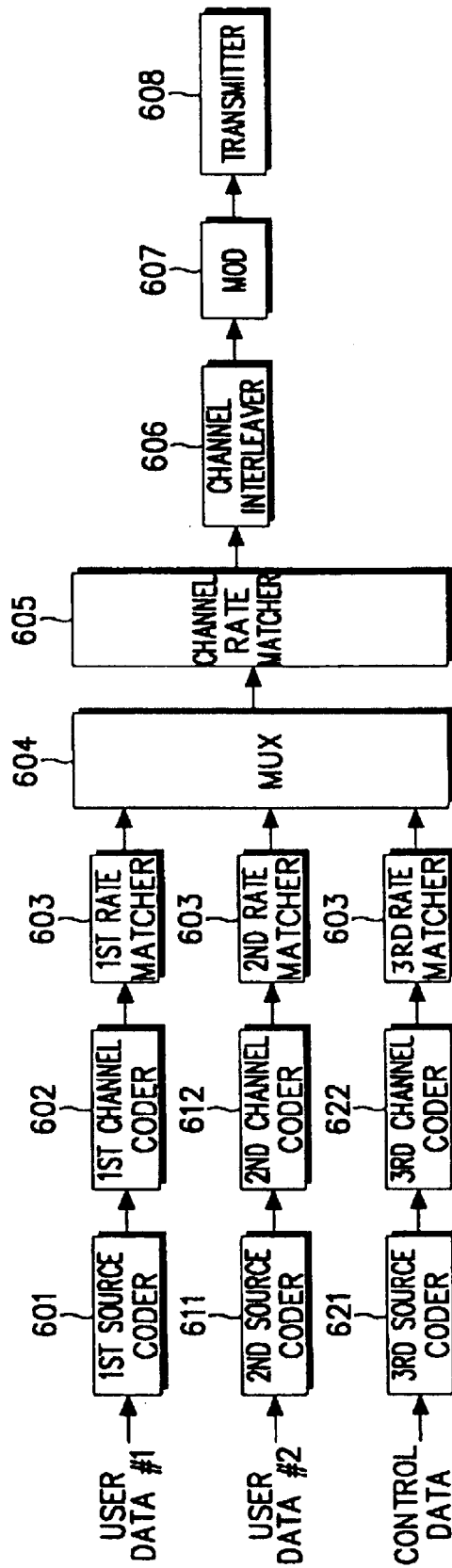

FIG. 6

PRIOR ART

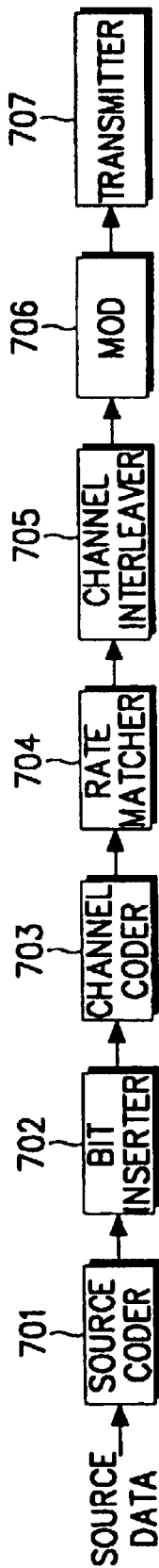

FIG. 7

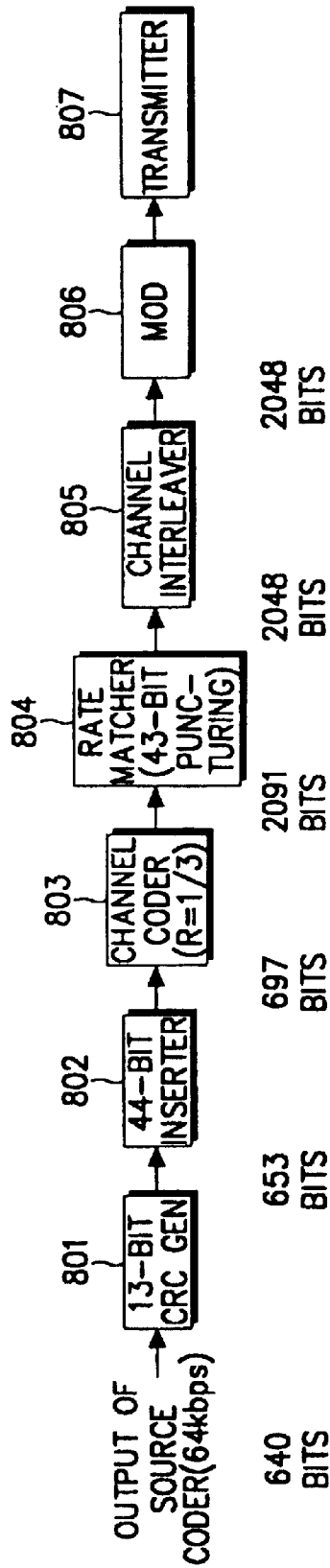

FIG. 8A

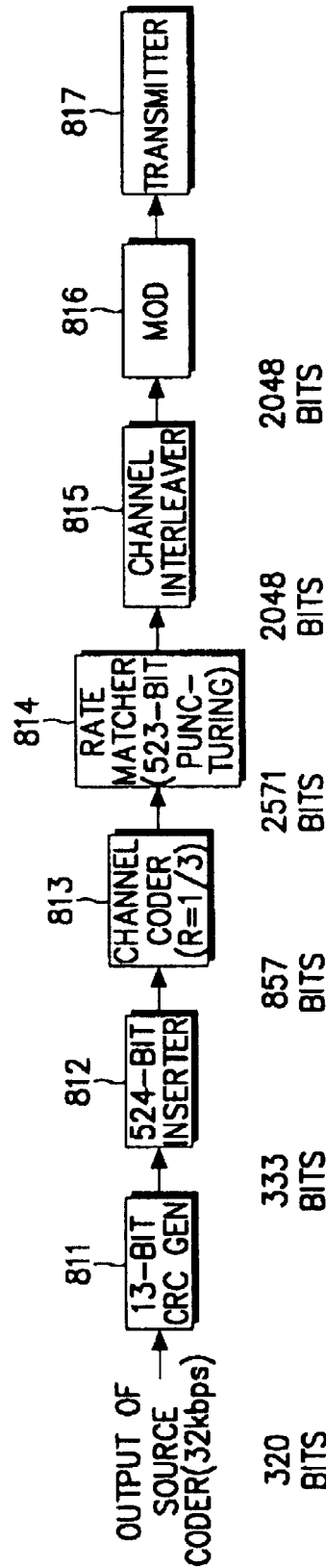

FIG. 8B

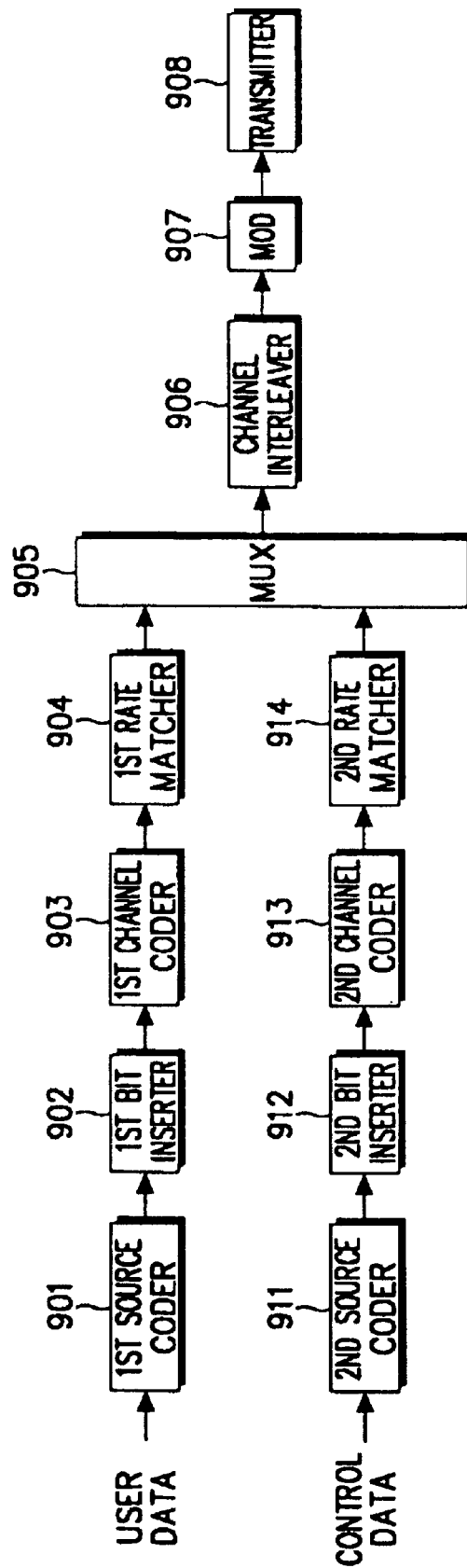

FIG. 9

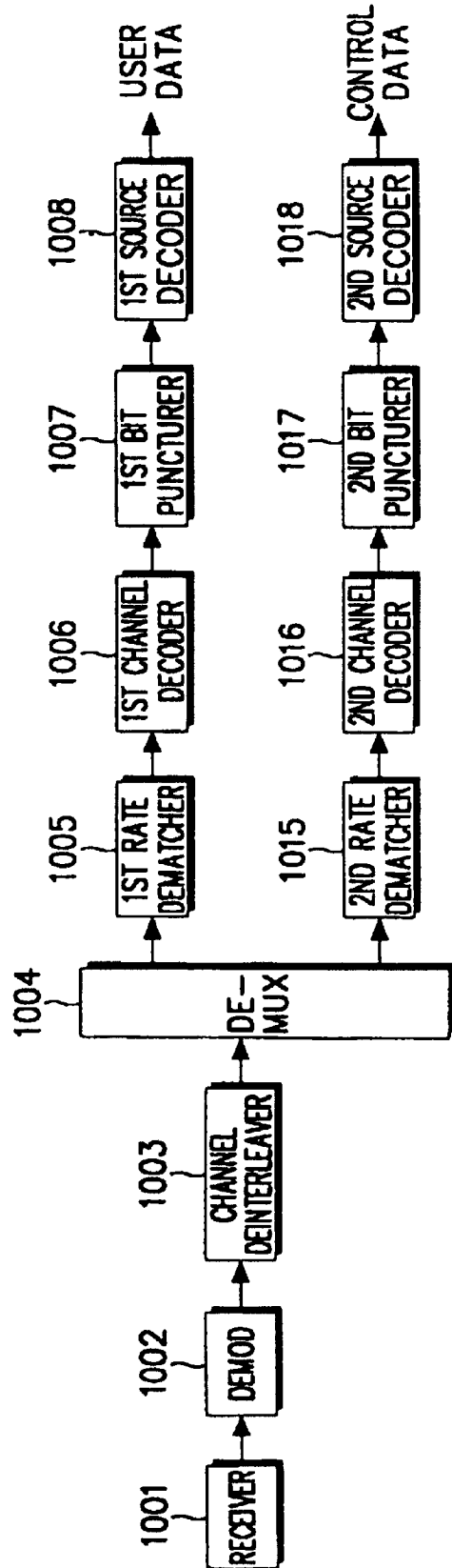

FIG. 10



FIG. 11

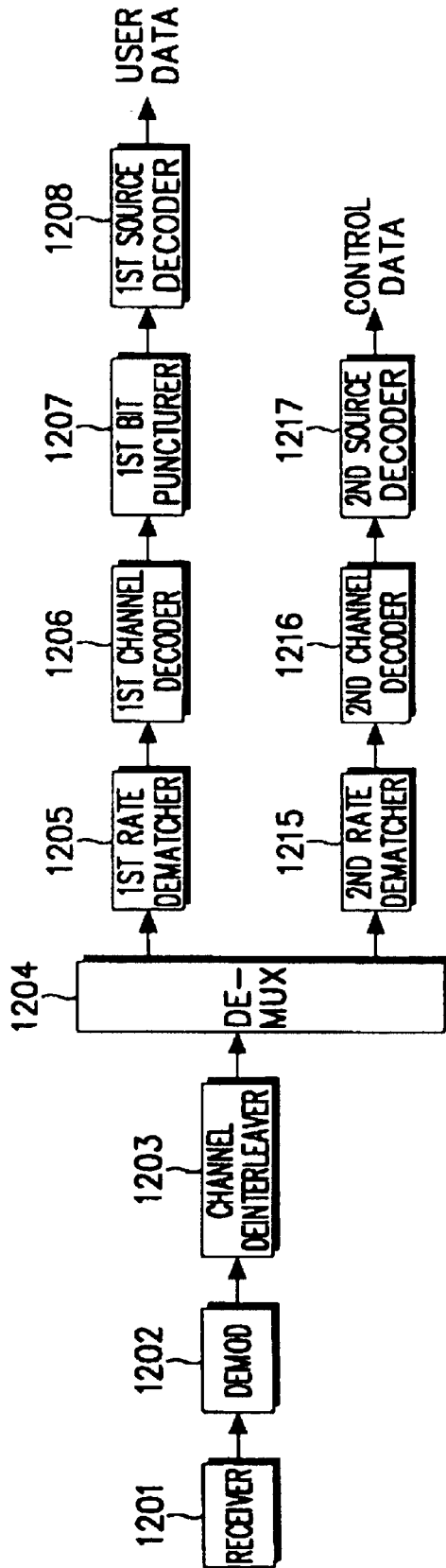

FIG. 12

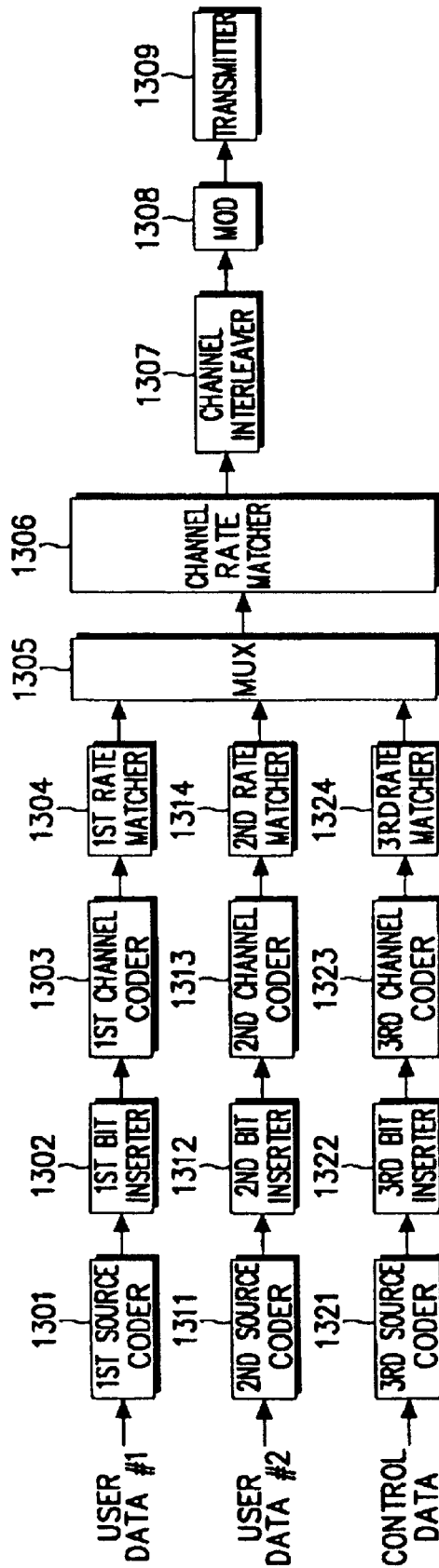

FIG. 13

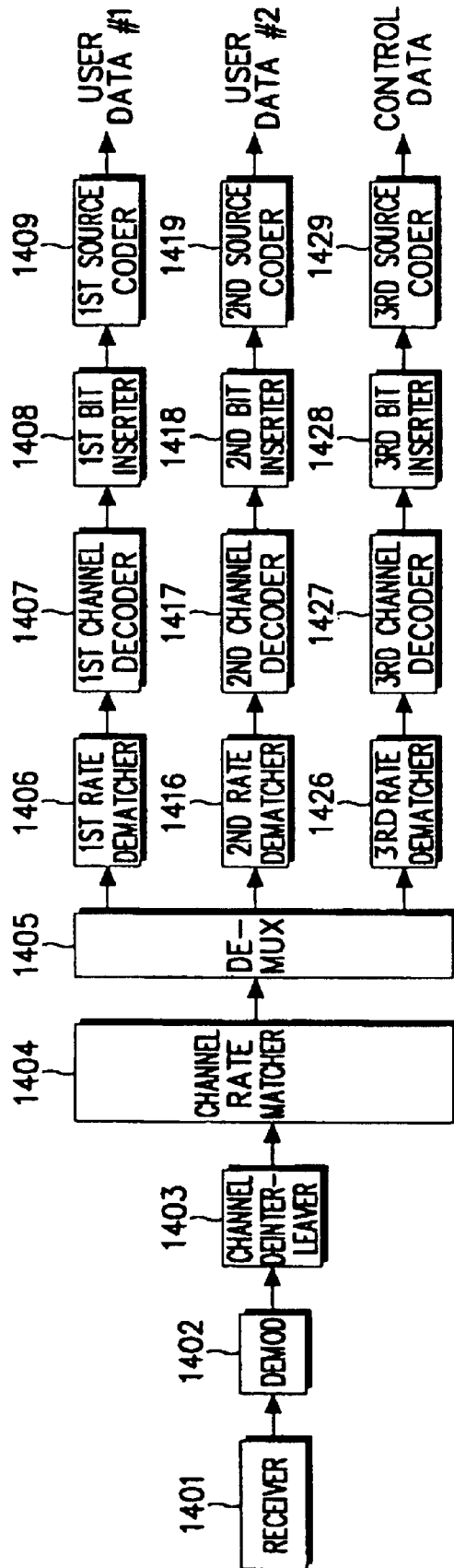

FIG. 14

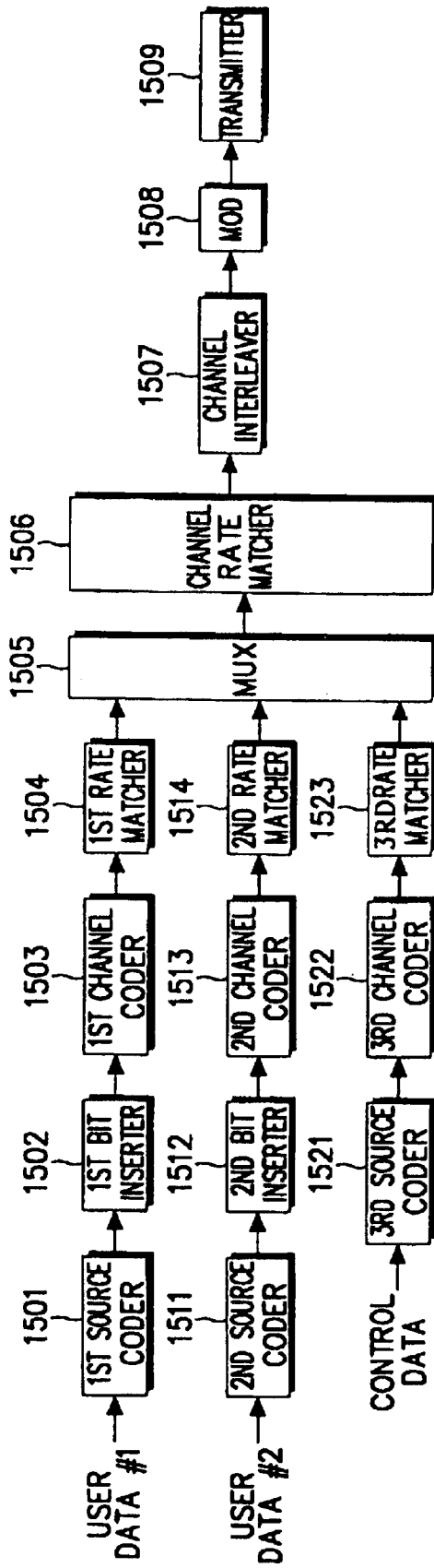

FIG. 15

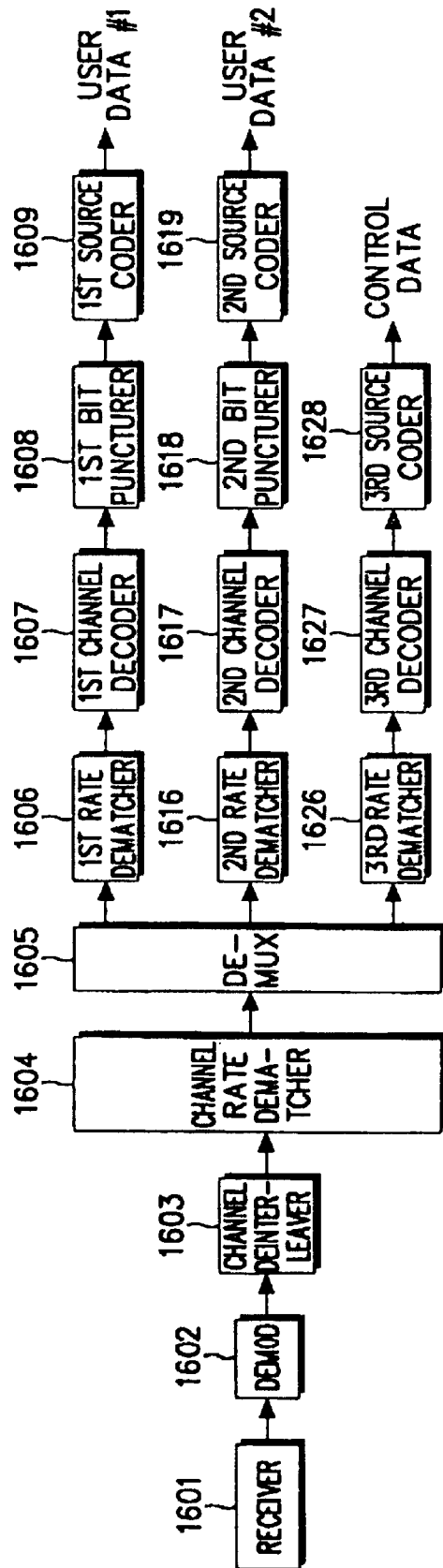

FIG. 16

**DEVICE AND METHODS FOR CHANNEL
CODING AND RATE MATCHING IN A
COMMUNICATION SYSTEM**

Matter enclosed in heavy brackets [] appears in the original patent but forms no part of this reissue specification; matter printed in italics indicates the additions made by reissue.

PRIORITY

This application claims priority to an application entitled "Channel Coding Device and Method" filed in the Korean Industrial Property Office on Jun. 5, 1998 and assigned Ser. No. 98-20990, the contents of which are hereby incorporated by reference.

BACKGROUND OF THE INVENTION

1. Field of the Invention

The present invention relates generally to a channel coding device and method for a communication system. Specifically, the present invention relates to a rate matching device and methods for inserting known bits in an input source data bit stream, channel coding the bit-inserted data stream and then, puncturing the channel coded data symbols.

2. Description of the Related Art

In a communication system, a rate of source user data is changed to a rate of channel symbols during data transmission via a channel. Particularly, in a spread spectrum communication system, since a chip rate for spreading is fixed, a channel symbol rate should be changed in order to be a multiple of the chip rate after multiplexing various service channels. Such a procedure is called rate matching.

With reference to FIG. 1, there is illustrated a block diagram of a conventional rate matching scheme for a source data rate of 64 Kbps. A CRC (Cyclic Redundancy Code) generator **101** adds 13 CRC bits to source coded user data input. A rate $\frac{1}{3}$ ($R=\frac{1}{3}$) channel coder **102** codes the CRC-added data into $653 \times 3 = 1959$ symbols. Herein, a description will be made regarding a method of changing the number of data symbols to be transmitted from 1959 symbols to 2048 symbols. To this end, a rate matcher **103** repeats 89 symbols. However, a simple symbol repetition may cause degradation in performance of the system according to a channel condition as discussed in CSELT, "Power Control Parameters Optimization in W-CDMA Down-Link", SMG2 Layer 1 Expert Group Agenda Item 7, Oslo, Apr. 1-2, 1998 (the CSELT Reference).

The channel coder **102** of FIG. 1 includes a convolutional coder, a Reed-Solomon coder, a concatenated coder in which the convolutional coder is coupled to the Reed-Solomon coder, and a turbo coder in which plural convolutional coders are coupled in series or parallel. Herein, a detailed description of the respective coders will be avoided for convenience. Instead, a description will be made as to the turbo coder. The turbo coder, a parallel concatenated coder, codes N-bit frame data into parity symbols using two simple parallel concatenated codes, wherein recursive systematic convolutional (RSC) codes are generally used for the constituent codes.

FIGS. 2 and 4 are block diagrams illustrating a conventional turbo coder and a turbo decoder, respectively. Reference can be made to U.S. Pat. No. 5,446,747 issued on Aug. 29, 1995 to Berrou for a comprehensive description. The turbo coder of FIG. 2 includes a first constituent coder **201**, a second constituent coder **202**, and an interleaver **211** inter-

connected between the constituent coders **201** and **202**. For the first and second coders **201** and **202**, an RSC coder is typically used, which is well-known in the art. The interleaver **211** has the same size as a frame length, N, of input data bit stream d_k , and changes arrangement of the input data bit stream d_k to be provided to the second constituent coder **202** to decrease the correlation among the data bits. Therefore, an output parallel concatenated code for the input data bit stream d_k becomes x_k (i.e., d_k without modification) and y_{1k} , and y_{2k} .

A turbo decoder for decoding the output of the turbo coder of FIG. 2 is disclosed in U.S. Pat. No. 5,446,747, and schematically illustrated in FIG. 4. Since the turbo decoder iteratively decodes received data in a frame unit using a MAP (Maximum A Posterior Probability) decoding algorithm, an increase in frequency of iterative decoding will decrease a bit error rate (BER). For the turbo decoder, a MAP decoder or a SOVA (Soft-Out Viterbi Algorithm) decoder is typically used, which can provide soft-decision iterative decoding.

FIG. 3 illustrates a convolutional coder with a constraint length 9 ($K=2$) and a coding rate $\frac{1}{3}$ ($R=\frac{1}{3}$). For decoding an output of the convolutional coder, a Viterbi decoder is generally used which employs a Viterbi algorithm. A detailed description of the Viterbi decoder is avoided herein.

FIG. 5 is a block diagram illustrating a transmission part of a known communication system, which multiplexes user data and control data and transmits the multiplexed data. The user data is coded by a first source coder **501** and a first channel coder **502**. Further, the control data is coded by a second source coder **511** and a second channel coder **512** and then multiplexed with the coded user data by a multiplexer **503**. The multiplexed user data and control data is rate matched at a rate matcher **504** by symbol repetition, puncturing or puncturing-after-symbol repetition. The rate matched symbols are provided to a transmitter **507** via a channel interleaver **505** and a modulator **506**.

FIG. 6 is a block diagram illustrating a transmission part of another known communication system which multiplexes first and second user data and control data and transmits the multiplexed data. The first and second user data are channel coded by first and second channel coders **602** and **612**, respectively, and then, rate matched by first and second rate matchers **603** and **613** according to their service option and class by symbol repetition, puncturing or puncturing-after-symbol repetition. Similarly, the control data is channel coded by a third channel coder **622** and then, rate matched by a third rate matcher **623**. Outputs of the first to third rate matchers **603**, **613** and **623** are multiplexed by a multiplexer **604** and then, finally rate matched by a channel rate matcher **605**. The channel rate matched symbols are provided to a transmitter **608** via a channel interleaver **606** and a modulator **607**.

A description will now be made as to symbol repetition performed for matching rates of symbols outputted from the channel coders **602**, **612** and **622**. A simple repetition of the channel coded symbols is a very simple symbol repetition method. However, the simple symbol repetition is not suitable for error correction. This is because in the light of the channel coded symbols, although a BER for the case where all the symbols are repeated two times (i.e., a rate $\frac{1}{2}$) is similar to a BER for the case where the symbols are not repeated (i.e., a rate 1), a performance degradation may occur according to a channel condition in the case where the respective symbols are unequally repeated (see the CSELT Reference). Therefore, when unequal symbol repetition is performed for rate matching, efficiency of the overall system typically decreases.

Further, reference will be made to a turbo coder of FIG. 2 having a constraint length 3 ($K=3$). Outputs of the turbo coder include non-coded data bit x_k and channel coded data parity bits y_{1k} and y_{2k} . When the data bit x_k is punctured for rate matching or various symbol rates, performance degradation is significant. In addition, when the parity bits y_{1k} and y_{2k} are simultaneously punctured at a time k , there exist no parity bits for a data bit at the time k . In the $K=3$ turbo coder, when the same parity bits y_{1k} and y_{1k+1} or the same parity bits y_{2k} and y_{2k+1} are simultaneously punctured, there exist no parity bits for data bits at the time k and $k+1$, so that a performance degradation occurs even though iterative decoding is performed. That is, when the parity bits outputted from the first and second constituent coders are consecutively punctured as many as the number of memories in the turbo coder, performance degradation occurs.

Therefore, for rate matching which requires symbol repetition, it is possible to guard against performance degradation by providing a channel coder which inserts specific bits in an input data bit stream and encodes the bit-inserted data bit stream. It is assumed herein that a value of the specific bits and bit inserting positions where the specific bits are to be inserted are known to both a transmission party and a reception party. Moreover, when puncturing is required for the channel coded symbols, the turbo coder selects puncturing positions for the parity bits, such that performance degradation due to puncturing is minimized.

SUMMARY OF THE INVENTION

It is, therefore, an object of the present invention to minimize performance degradation of a communication system during symbol repetition, puncturing and puncturing-after-symbol repetition in a rate matching device.

It is another object of the present invention to provide a rate matching device and method for inserting known bits in an input source data bit stream, channel coding the bit-inserted data bit stream and thereafter puncturing the channel coded data symbols.

It is further another object of the present invention to minimize performance degradation caused during puncturing by selecting acceptable symbol puncturing positions when performing rate matching for input channel coded symbols.

To achieve the above objects, there is provided a channel coding device. In the device, a bit inserter inserts known bits in an input data bit stream at predetermined positions. A channel coder codes the bit-inserted data bit stream to generate coded symbols. A rate matcher matches a rate of the coded symbols to a given channel symbol rate. A channel interleaver interleaves the rate matched channel symbols. The rate matcher includes a puncturer for puncturing the inserted known bits included in the coded symbols when the coded symbol rate is higher than the given channel symbol rate. The rate matcher includes a repeater for repeating the coded symbols to match the coded symbol rate to the given channel symbol rate when the coded symbol rate is lower than the given channel symbol rate.

BRIEF DESCRIPTION OF THE DRAWINGS

The above and other objects, features and advantages of the present invention will become more apparent from the following detailed description when taken in conjunction with the accompanying drawings, in which:

FIG. 1 is a block diagram illustrating a conventional rate matching scheme for a data rate of 64 Kbps;

FIG. 2 is a block diagram illustrating a conventional turbo coder;

FIG. 3 is a diagram illustrating a conventional convolutional coder;

FIG. 4 is a block diagram illustrating a conventional turbo decoder;

FIG. 5 is a block diagram illustrating a transmission part of a conventional communication system;

FIG. 6 is a block diagram illustrating a transmission part of another conventional communication system;

FIG. 7 is a block diagram illustrating a transmission part of a communication system according to a first embodiment of the present invention;

FIG. 8A is a block diagram illustrating a rate matching scheme where a source coder has a data rate of 64 Kbps;

FIG. 8B is a block diagram illustrating a rate matching scheme where a source coder has a data rate of 32 Kbps;

FIG. 9 is a block diagram illustrating a transmission part of a communication system according to a second embodiment of the present invention;

FIG. 10 is a block diagram illustrating a reception part corresponding to the transmission part of FIG. 9;

FIG. 11 is a block diagram illustrating a transmission part of a communication system according to a third embodiment of the present invention;

FIG. 12 is a block diagram illustrating a reception part corresponding to the transmission part of FIG. 11;

FIG. 13 is a block diagram illustrating a transmission part of a communication system according to a fourth embodiment of the present invention;

FIG. 14 is a block diagram illustrating a reception part corresponding to the transmission part of FIG. 13;

FIG. 15 is a block diagram illustrating a transmission part of a communication system according to a fifth embodiment of the present invention; and

FIG. 16 is a block diagram illustrating a reception part corresponding to the transmission part of FIG. 15.

DETAILED DESCRIPTION OF THE PREFERRED EMBODIMENTS

Preferred embodiments of the present invention will be described herein below with reference to the accompanying drawings. In the following description, well known functions or constructions are not described in detail since they would obscure the invention in unnecessary detail.

It is assumed herein that a $K=3$ RSC coder is used for both first and second constituent coders. A soft-decision iterative decoder is used for the first and second constituent coders. Further, a MAP or SOVA decoder can be used for the soft-decision iterative decoder. In addition, not only an RSC coder but also a non-RSC coder can be used for the first and second constituent coders. Moreover, the first and second constituent coders may use different constraint lengths and generator polynomials.

A. First Embodiment

FIG. 7 is a block diagram illustrating a rate matching scheme for a channel coding device according to a first embodiment of the present invention. A source coder 701 codes input source data according to a predetermined coding method. Here, the source data includes user data and control data. A bit inserter 702 inserts a predetermined number of known bits in the coded source data at predetermined

positions, in order to transmit the coded source data at a specific data rate. The number of the inserting bits and the positions where the inserting bits are inserted, are previously scheduled with receiving devices. A channel coder **703** codes the data outputted from the bit inserter **702** at a specific coding rate and outputs coded symbols (including data symbols and parity symbols). A turbo coder or a convolutional coder can be used for the channel coder **703**.

A rate matcher **704** matches a rate of symbol data outputted from the channel coder **703** to a symbol rate of the transmission channel. The rate matcher **704** can be composed of a repeater and a puncturer. Also, the rate matcher **704** can be composed of any one of the repeater and the puncturer. A channel interleaver **705** interleaves the rate matched symbols. A modulator **706** modulates the channel interleaved symbol data. The modulator **706** may employ code division multiple access (CDMA) modulation techniques. A transmitter **707** converts the modulated transmission data to an RF signal and transmits the converted RF signal.

When a coded symbol rate is higher than a given channel symbol rate, the rate matcher **704** can be implemented by a puncturer for puncturing the symbols. However, when the coded symbol rate is lower than the given channel symbol rate, the rate matcher **704** can be implemented by a repeater for repeating the symbols to match the coded symbol rate to the given channel symbol rate. Alternatively, when the coded symbol rate is lower than the given channel symbol rate, the rate matcher **704** can be implemented by a repeater for repeating the symbols to approximately match the symbol rate to the given symbol rate and a puncturer for matching a rate of the repeated symbols to the given channel symbol rate.

For the channel coder **703**, a $K=3$ turbo coder or a $K=9$ convolutional coder can be used.

In addition, a portion having a high error occurrence probability of an overall input data frame can be reinforced during bit insertion. With respect to performance of the channel coder, since a previously known value, i.e., a high reliability is used during decoding, an error rate is reduced in finding a survival path on a trellis of a decoder. The bit insertion technique which uses the bits previously known to both the transmission party and the reception party provides a higher performance at all the traveling velocities, and an increase in the number of the inserting bits increases the performance. Further, the bit inserter can vary the number of inserting bits according to a service option and class for the source user data or according to a service option and class for the control data.

The bit-inserted input data is channel coded by the channel coder **703** and the channel coded symbols are provided to the rate matcher **704** which matches a rate of the channel coded symbols to a specific symbol rate by puncturing. This procedure will be described below, by way of example.

FIG. **8A** is a block diagram illustrating a rate matching procedure in the case where the source coder **701** has a data rate 64 Kbps, and FIG. **8B** is a block diagram illustrating a rate matching procedure in the case where the source coder **701** has a data rate 32 Kbps. It is assumed herein that a $K=3$ turbo coder is used for the channel coder **703**. A CRC generator **801** adds 13 CRC bits to 640 bits per frame (i.e., data rate of 64 Kbps) outputted from the source coder **701** to output 653 bits. A bit inserter **802** inserts 44 bits of "0" or "1" in data outputted from the CRC generator **801** to output $653+44=697$ bits. An $R=1/3$ channel coder **803** encodes the 697 bits into 2091 symbol bits ($697 \times 3=2091$). A rate matcher **804** punctures 43 bits inserted in the data outputted from the source coder **701** to output $2091-43=2048$ bits.

Since the transmission party and the reception party both know the value and positions of the 43 bits inserted in the data outputted from the source coder **701**, it is not necessary to actually transmit the bits via the channel. Therefore, the rate matcher **804** outputs 2048 rate matched symbols by puncturing 43 inserted bits. Since this technique provides many data bits previously known to both the transmission party and the reception party, an error probability is drastically reduced in tracing a survival path on a trellis during decoding. The number of the inserting bits varies according to a data rate.

Referring to FIG. **8B**, there is illustrated a rate matching scheme in the case where the source coder **701** has a data rate of 32 Kbps. In this case, a bit inserter **812** inserts 524 bits in 333-bit frame data outputted from a CRC generator **811** to output 857 bits, and an $R=1/3$ channel coder **813** encodes the 857 bits into 2571 symbol bits ($857 \times 3=2571$). A rate matcher **814** punctures 523 symbols from the 2571 symbols to output 2048 symbols.

In the meantime, when a turbo coder is used for the channel coder **703** of FIG. **7**, the turbo coded symbols assume the recursive systematic form, so that a data bit x_k is transmitted, as it is, without coding. In the case where the data bit x_k for a turbo code is punctured for rate matching, performance degradation becomes more significant as compared with the case where other parity bits are punctured. Therefore, it is preferable not to puncture the data bit x_k .

Further, in the conventional turbo coder of FIG. **2**, when the parity bits outputted from the first constituent coder **201** for the $K=3$ turbo coder are consecutively punctured at time k and $k+1$ there exist no parity bits for the data bit x_k at a time k . This is the same even for the second constituent coder **202**. In addition, when a parity bit y_{1k} from the first constituent coder **201** and a parity bit y_{2k} from the second constituent coder **202** are both punctured at time k , there exist no parity bits for decoding the data bit x_k at time k . Therefore, to solve this problem, the parity bits from the first or second constituent coder **201** or **202** should not be consecutively punctured. In addition, the parity bits from the first and second constituent coders **201** and **202** should not be punctured simultaneously.

In general, a transmission party exchanges rate information with a reception party in the process of call setup. However, when the rate information is not directly transmitted from the transmission party to the reception party, the reception party decodes a received signal according to predetermined various data rates and thereafter, checks a CRC included in the received data frame to detect the data rate. Therefore, in a system where a rate is matched by inserting specific bits in a data bit stream, when the reception party cannot be directly provided with the rate information in the call setup process, the reception party can perform decoding by changing the number of inserting bits, which is predetermined according to the data rate, and thereafter, checks a CRC in the data frame to determine where the data rate has an error.

B. Second Embodiment

With reference to FIG. **9**, there is shown a block diagram of a rate matching scheme for a channel coding device according to a second embodiment of the present invention. The channel coding device inserts known bits at predetermined positions, for rate matching for both user data and control data.

A first source coder **901** codes input source user data according to a predetermined coding method. A first bit

inserter **902** inserts a predetermined number of known bits in the coded source data at predetermined positions, in order to transmit the coded source data at a specific data rate. The number of inserting bits and the positions where the inserting bits are inserted are previously scheduled with receiving devices. A first channel coder **903** codes the data outputted from the first bit inserter **902** at a specific coding rate and outputs user symbols (including data symbols and parity symbols). A turbo coder or a convolutional coder can be used for the first channel coder **903**. A first rate matcher **904** matches a rate of symbol data outputted from the first channel coder **903** to a symbol rate of the transmission channel. The first rate matcher **904** can be composed of a repeater for repeating input data and a puncturer for puncturing the repeated symbol data. Also, the first rate matcher **904** can be composed of any one of the repeater and the puncturer.

More specifically, when a coded user symbol rate is higher than a given channel user symbol rate, the first rate matcher **904** can be implemented by a puncturer for puncturing the user symbols. However, when the coded user symbol rate is lower than the given channel user symbol rate, the first rate matcher **904** can be implemented by a repeater for repeating the user symbols to match the user symbol rate to the given channel user symbol rate. Alternatively, when the coded user symbol rate is lower than the given channel user symbol rate, the first rate matcher **904** can be implemented by a repeater for repeating the user symbols to approximately match the user symbol rate to the given channel user symbol rate and a puncturer for matching a rate of the repeated user symbols to the given channel user symbol rate.

Furthermore, a second source coder **911** codes input source control data according to a predetermined coding method. A second bit inserter **912** inserts a predetermined number of bits in the coded source data, in order to transmit the coded source data at a specific data rate. The number of inserting bits and the positions where the inserting bits are inserted are previously scheduled with receiving devices. A second channel coder **913** codes the data outputted from the second bit inserter **912** at a specific coding rate and outputs data symbols and parity symbols. A turbo coder or a convolutional coder can be used for the second channel coder **913**. A second rate matcher **914** matches a rate of symbol data outputted from the second channel coder **913** to a symbol rate of the transmission channel. The second rate matcher **914** can be composed of a repeater for repeating input data and a puncturer for puncturing the repeated symbol data. Also, the second rate matcher **914** can be composed of any one of the repeater and the puncturer.

More specifically, when a coded control symbol rate is higher than a given channel control symbol rate, the second rate matcher **914** can be implemented by a puncturer for puncturing the control symbols. However, when the coded control symbol rate is lower than the given channel control symbol rate, the second rate matcher **914** can be implemented by a repeater for repeating the control symbols to match the control symbol rate to the given channel control symbol rate. Alternatively, when the coded control symbol rate is lower than the given channel control symbol rate, the second rate matcher **914** can be implemented by a repeater for repeating the control symbols to approximately match the control symbol rate to the given channel control symbol rate and a puncturer for matching a rate of the repeated control symbols to the given channel control symbol rate.

A multiplexer **905** multiplexes the rate matched user data symbols and control data symbols, and a channel interleaver **906** interleaves the rate matched symbol data. A modulator **907** modulates the channel interleaved symbol data. The

modulator **907** may employ CDMA modulation techniques. A transmitter **908** converts the modulated transmission data to an RF signal and transmits the converted RF signal.

FIG. **10** is a block diagram illustrating a reception part for a communication system having the channel coder of FIG. **9**. A signal received via a transmission channel (or receiver) **1001** is demodulated by a demodulator **1002**, and demultiplexed by a demultiplexer **1004** into user data and control data after channel deinterleaving at a channel deinterleaver **1003**. The demultiplexed user data experiences symbol combination or insertion at a first rate dematcher **1005**, and a first channel decoder **1006** decodes the rate dematched user data. Since the decoded data includes the bits inserted by the first bit inserter **902** of FIG. **9**, a first bit puncturer **1007** deletes (or punctures) the data bits as many as the number of the bits inserted by the first bit inserter **902** of the transmission party. A first source decoder **1008** decodes the bit-punctured data to output the user data.

Further, the demultiplexed control data experiences symbol combination or insertion at a second rate dematcher **1015**, and a second channel decoder **1016** decodes the rate dematched control data. Since the decoded data includes the bits inserted by the second bit inserter **912** of FIG. **9**, a second bit puncturer **1017** punctures the data bits as many as the number of the bits inserted by the second bit inserter **912** of the transmission party. A second source decoder **1018** decodes the bit-punctured data to output the control data. For the channel decoders **1006** and **1016** of FIG. **10**, a Viterbi decoder can be used when a convolutional code is used and a soft-decision iterative decoder can be used when a turbo code is used.

C. Third Embodiment

FIG. **11** is a block diagram illustrating a rate matching scheme for a channel coding device according to a third embodiment of the present invention. The channel coding device inserts known bits at predetermined positions, for rate matching for user data, and does not insert the know bits, for rate matching for control data. A first source coder **1101** codes input source user data according to a predetermined coding method. A first bit inserter **1102** inserts a predetermined number of known bits in the coded source data at predetermined positions, in order to transmit the coded source data at a specific data rate. The number of the inserting bits and the positions where inserting bits are inserted are previously scheduled with receiving devices. A first channel coder **1103** codes the data outputted from the first bit inserter **1102** at a specific coding rate and outputs user symbols (including data symbols and parity symbols). A turbo coder or a convolutional coder can be used for the first channel coder **1103**. A first rate matcher **1104** matches a rate of symbol data outputted from the first channel coder **1103** to a symbol rate of the transmission channel. The first rate matcher **1104** can be composed of a repeater for repeating input data and a puncturer for puncturing the repeated symbol data. Also, the first rate matcher **1104** can be composed of any one of the repeater and the puncturer.

More specifically, when a coded user symbol rate is higher than a given channel user symbol rate, the first rate matcher **1104** can be implemented by a puncturer for puncturing the user symbols. However, when the coded user symbol rate is lower than the given channel user symbol rate, the first rate matcher **1104** can be implemented by a repeater for repeating the user symbols to match the user symbol rate to the given channel user symbol rate. Alternatively, when the coded user symbol rate is lower than the given channel user

symbol rate, the first rate matcher **1104** can be implemented by a repeater for repeating the user symbols to approximately match the user symbol rate to the given channel user symbol rate and a puncturer for matching a rate of the repeated user symbols to the given channel user symbol rate.

Furthermore, a second source coder **1111** codes input source control data according to a predetermined coding method. A secured channel coder **1112** codes the data outputted from the second source coder **1111** at a specific coding rate and output data symbols and parity symbols. A turbo coder or a convolutional coder can be used for the second channel coder **1112**. A second rate matcher **1113** matches a rate of symbol data outputted from the second channel coder **1112** to a symbol rate of the transmission channel. The second rate matcher **1113** can be composed of a repeater for repeating input data and a puncturer for puncturing the repeated symbol data. Also, the second rate matcher **1113** can be composed of any one of the repeater and the puncturer.

More specifically, when a coded control symbol rate is higher than a given channel control symbol rate, the second rate matcher **1113** can be implemented by a puncturer for puncturing the control symbols. However, when the coded control symbol rate is lower than the given channel control symbol rate, the second rate matcher **1113** can be implemented by a repeater for repeating the control symbols to match the control symbol rate to the given channel control symbol rate. Alternatively, when the coded control symbol rate is lower than the given channel control symbol rate, the second rate matcher **1113** can be implemented by a repeater for repeating the control symbols to approximately match the control symbol rate to the given channel control symbol rate and a puncturer for matching a rate of the repeated control symbols to the given channel control symbol rate.

A multiplexer **1105** multiplexes the rate matched user data symbols and control data symbols, and a channel interleaver **1106** interleaves the rate matched symbol data. A modulator **1107** modulates the channel interleaved symbol data. The modulator **1107** may employ CDMA modulation techniques. A transmitter **1108** converts the modulated transmission data to an RF signal and transmits the converter RF signal.

FIG. **12** is a block diagram illustrating a reception part for a communication system having the channel coder of FIG. **11**. Referring to FIG. **12**, a signal received via a transmission channel (or receiver) **1201** is demodulated by a demodulator **1202**, and demultiplexed by a demultiplexer **1204** into user data and control data after channel deinterleaving at a channel deinterleaver **1203**. The demultiplexed user data experiences symbol combination or insertion at a first rate dematcher **1205**, and a first channel decoder **1206** decodes the rate dematched user data. Since the decoded data includes the bits inserted by the first bit inserter **1102** of FIG. **11**, a first bit puncturer **1207** punctures the data bits as many as the number of the bits inserted by the first bit inserter **1102** of the transmission party. A first source decoder **1208** decodes the bit-punctured data to output the user data.

Moreover, the demultiplexed control data experiences symbol combination or insertion at a second rate dematcher **1215**, and a second channel decoder **1216** decodes the rate dematched control data. A second source decoder **1217** decodes the decoded data to output the control data. For the channel decoders **1206** and **1216** of FIG. **12**, a Viterbi decoder can be used when a convolutional code is used and a soft-decision iterative decoder can be used when a turbo code is used.

D. Fourth Embodiment

FIG. **13** is a block diagram illustrating a rate matching scheme for a channel coding device according to a fourth embodiment of the present invention. The channel coding device inserts known bits at predetermined positions, for rate matching for first and second user data and control data. Although a description will be made with reference to an embodiment supporting two sets of user data, the number of the user data sets can be expanded.

A first source coder **1301** codes first input user data according to a predetermined coding method. A first bit inserter **1302** inserts a predetermined number of known bits in the coded source data at predetermined positions, in order to transmit the coded source data at a specific data rate. The number of inserting bits and the positions where the inserting bits are inserted are previously scheduled with receiving devices. A first channel coder **1303** codes the data outputted from the first bit inserter **1302** at a specific coding rate to output user symbols (including data symbols and parity symbols). A turbo coder or a convolutional coder can be used for the first channel coder **1303**. A first rate matcher **1304** matches a rate of symbol data outputted from the first channel coder **1303** to a symbol rate of the transmission channel. The first rate matcher **1304** can be composed of a repeater for repeating input data and a puncturer for puncturing the repeated symbol data. Also, the first rate matcher **1304** can be composed of any one of the repeater and the puncturer.

More specifically, when a coded user symbol rate is higher than a given channel user symbol rate, the first rate matcher **1304** can be implemented by a puncturer for puncturing the user symbols. However, when the coded user symbol rate is lower than the given channel user symbol rate, the first rate matcher **1304** can be implemented by a repeater for repeating the user symbols to match the user symbol rate to the given channel user symbol rate. Alternatively, when the coded user symbol rate is lower than the given channel user symbol rate, the first rate matcher **1304** can be implemented by a repeater for repeating the user symbols to approximately match the user symbol rate to the given channel user symbol rate and a puncturer for matching a rate of the repeated user symbols to the given channel user symbol rate.

Further, a second source coder **1311** codes second input user data according to a predetermined coding method. A second bit inserter **1312** inserts a predetermined number of known bits in the coded source data at predetermined positions, in order to transmit the coded source data at a specific data rate. The number of inserting bits and the positions where the inserting bits are inserted are previously scheduled with receiving devices. A second channel coder **1313** codes the data outputted from the second bit inserter **1312** at a specific coding rate to output user symbols (including data symbols and parity symbols). A turbo coder or a convolutional coder can be used for the second channel coder **1313**. A second rate matcher **1314** matches a rate of symbol data outputted from the second channel coder **1313** to a symbol rate of the transmission channel. The second rate matcher **1314** can be composed of a repeater for repeating input data and a puncturer for puncturing the repeated symbol data. Also, the second rate matcher **1314** can be composed of any one of the repeater and the puncturer.

More specifically, when a coded user symbol rate is higher than a given channel user symbol rate, the second rate matcher **1314** can be implemented by a puncturer for puncturing the user symbols. However, when the coded user symbol rate is lower than the given channel user symbol rate, the

second rate matcher **1314** can be implemented by a repeater for repeating the user symbols to match the user symbol rate to the given channel user symbol rate. Alternatively, when the coded user symbol rate is lower than the given channel user symbol rate, the second rate matcher **1314** can be implemented by a repeater for repeating the user symbols to approximately match the user symbol rate to the given channel user symbol rate and a puncturer for matching a rate of the repeated user symbols to the given channel user symbol rate.

Moreover, a third source coder **1321** codes input source control data according to a predetermined coding method. A third bit inserter **1322** inserts a predetermined number of known bits in the coded source data at predetermined positions, in order to transmit the coded source data at a specific data rate. The number of inserting bits and the positions where the inserting bits are inserted are previously scheduled with receiving devices. A third channel coder **1323** codes the data outputted from the third bit inserter **1322** at a specific coding rate to output control symbols (including data symbols and parity symbols). A turbo coder or a convolutional coder can be used for the third channel coder **1323**. A third rate matcher **1324** matches a rate of symbol data outputted from the third channel coder **1323** to a symbol rate of the transmission channel. The third rate matcher **1324** can be composed of a repeater for repeating input data and a puncturer for puncturing the repeated symbol data. Also, the third rate matcher **1324** can be composed of any one of the repeater and the puncturer.

More specifically, when a coded control symbol rate is higher than a given channel control symbol rate, the third rate matcher **1324** can be implemented by a puncturer for puncturing the control symbols. However, when the coded control symbol rate is lower than the given channel control symbol rate, the third rate matcher **1324** can be implemented by a repeater for repeating the control symbols to match the control symbol rate to the given channel control symbol rate. Alternatively, when the coded control symbol rate is lower than the given channel control symbol rate, the third rate matcher **1324** can be implemented by a repeater for repeating the control symbols to approximately match the control symbol rate to the given channel control symbol rate and a puncturer for matching a rate of the repeated control symbols to the given channel control symbol rate.

It is contemplated that the number of bits inserted at the first through third bit inserters **1302**, **1312** and **1322** can be varied according to the service options and classes of the first user data, the second user data and the control data.

A multiplexer **1305** multiplexes the rate matched user data symbols and control data symbols. A rate of the multiplexed data is matched to a channel symbol rate at a channel rate matcher **1306**, and the rate matched symbol data is interleaved by a channel interleaver **1307**. A modulator **1308** modulates the channel interleaved symbol data. The modulator **1308** may employ CDMA modulation techniques. A transmitter **1309** converts the modulated transmission data to an RF signal and transmits the converter RF signal.

In this embodiment, when a rate of the symbols outputted from the multiplexer **1305** is higher than a given channel symbol rate, the channel rate matcher **1306** can be implemented by a puncturer for puncturing the symbols. However, when the rate of the symbols outputted from the multiplexer **1305** is lower than the given channel control symbol rate, the channel rate matcher **1306** can be implemented by a repeater for repeating the symbols to match the symbol rate to the given channel symbol rate. Alternatively, when the rate of

the symbols outputted from the multiplexer **1305** is lower than the given channel symbol rate, the channel rate matcher **1306** can be implemented by a repeater for repeating the symbols to approximately match the symbol rate to the given channel symbol rate and a puncturer for matching a rate of the repeated symbols to the given channel symbol rate.

FIG. **14** is a block diagram illustrating a reception part for a communication system having the channel coder of FIG. **13**. A signal received via a transmission channel (or receiver) **1401** is demodulated by a demodulator **1402**. The demodulated data experiences symbol combination or insertion at a channel rate dematcher **1404** after channel deinterleaving at a channel deinterleaver **1403**, and the rate matched data is demultiplexed into first and second user data and control data by a demultiplexer **1405**. The first demultiplexed user data experiences symbol combination or insertion at a first rate dematcher **1406**, and a first channel decoder **1407** decodes the rate dematched user data. Since the decoded data includes the bits inserted by the first bit inserter **1302** of FIG. **13**, a first bit puncturer **1408** punctures the data bits as many as the number of the bits inserted by the first bit inserter **1302** of the transmission party. A first source decoder **1409** decodes the bit-punctured data to output the first user data.

Furthermore, the second demultiplexed user data experiences symbol combination or insertion at a second rate dematcher **1416**, and a second channel decoder **1417** decodes the rate dematched user data. Since the decoded data includes the bits inserted by the second bit inserter **1312** of FIG. **13**, a second bit puncturer **1418** punctures the data bits as many as the number of the bits inserted by the second bit inserter **1312** of the transmission party. A second source decoder **1419** decodes the bit-punctured data to output the second user data.

Moreover, the demultiplexed control data experiences symbol combination or insertion at a third rate dematcher **1426**, and a third channel decoder **1427** decodes the rate dematched control data. Since the decoded data includes the bits inserted by the third bit inserter **1322** of FIG. **13**, a third bit puncturer **1428** punctures the data bits as many as the number of the bits inserted by the third bit inserter **1322** of the transmission party. A third source decoder **1429** decodes the bit-punctured data to output the control data.

For the channel decoders **1407**, **1417** and **1427** of FIG. **14**, a Viterbi decoder can be used when a convolutional code is used and a soft-decision iterative decoder can be used when a turbo code is used.

E. Fifth Embodiment

FIG. **15** is a block diagram illustrating a rate matching scheme for a channel coding device according to a fifth embodiment of the present invention. The channel coding device inserts known bits at predetermined positions, for rate matching for first and second user data and control data. Although a description will be made with reference to an embodiment supporting two sets of user data, the number of the user data sets can be expanded.

A first source coder **1501** codes first input user data according to a predetermined coding method. A first bit inserter **1502** inserts a predetermined number of known bits in the coded source data at predetermined positions, in order to transmit the coded source data at a specific data rate. The number of inserting bits and the positions where the inserting bits are inserted are previously scheduled with receiving devices. A first channel coder **1503** codes the data outputted from the first bit inserter **1502** at a specific coding rate to

output user symbols (including data symbols and parity symbols). A turbo coder or a convolutional coder can be used for the first channel coder **1503**. A first rate matcher **1504** matches a rate of symbol data outputted from the first channel coder **1503** to a symbol rate of the transmission channel. The first rate matcher **1504** can be composed of a repeater for repeating input data and a puncturer for puncturing the repeated symbol data. Also, the first rate matcher **1504** can be composed of any one of the repeater and the puncturer.

More specifically, when a coded user symbol rate is higher than a given channel user symbol rate, and the first rate matcher **1504** can be implemented by a puncturer for puncturing the user symbols. However, when the coded user symbol rate is lower than the given channel user symbol rate, the first rate matcher **1504** can be implemented by a repeater for repeating the user symbols to match the user symbol rate to the given channel user symbol rate. Alternatively, when the coded user symbol rate is lower than the given channel user symbol rate, the first rate matcher **1504** can be implemented by a repeater for repeating the user symbols to approximately match the user symbol rate to the given channel user symbol rate and a puncturer for matching a rate of the repeated user symbols to the given channel user symbol rate.

Further, a second source coder **1511** codes second input user data according to a predetermined coding method. A second bit inserter **1512** inserts a predetermined number of known bits in the coded source data at predetermined positions, in order to transmit the coded source data at a specific data rate. The number of inserting bits and the positions where the inserting bits are inserted are previously scheduled with receiving devices. A second channel coder **1513** codes the data outputted from the second bit inserter **1512** at a specific coding rate to output user symbols (including data symbols and parity symbols). A turbo coder or a convolutional coder can be used for the second channel coder **1513**. A second rate matcher **1514** matches a rate of symbol data outputted from the second channel coder **1513** to a symbol rate of the transmission channel. The second rate matcher **1514** can be composed of a repeater for repeating input data and a puncturer for puncturing the repeated symbol data. Also, the second rate matcher **1514** can be composed of any one of the repeater and the puncturer.

More specifically, when a coded user symbol rate is higher than a given channel user symbol rate, the second rate matcher **1514** can be implemented by a puncturer for puncturing the user symbols. However, when the coded user symbol rate is lower than the given channel user symbol rate, the second rate matcher **1514** can be implemented by a repeater for repeating the user symbols to match the user symbol rate to the given channel user symbol rate. Alternatively, when the coded user symbol rate is lower than the given channel user symbol rate, the second rate matcher **1514** can be implemented by a repeater for repeating the user symbols to approximately match the user symbol rate to the given channel user symbol rate and a puncturer for matching a rate of the repeated user symbols to the given channel user symbol rate.

Moreover, a third source coder **1521** codes input source control data according to a predetermined coding method. A third channel coder **1522** codes the data outputted from the third source coder **1521** at a specific coding rate to output data symbols and parity symbols. A turbo coder or a convolutional coder can be used for the third channel coder **1522**. A third rate matcher **1523** matches a rate of symbol data outputted from the third channel coder **1522** to a symbol rate

of the transmission channel. The third rate matcher **1523** can be composed of a repeater for repeating input data and a puncturer for puncturing the repeated symbol data. Also, the third rate matcher **1523** can be composed of any one of the repeater and the puncturer.

More specifically, when a coded control symbol rate is higher than a given channel control symbol rate, the third rate matcher **1523** can be implemented by a puncturer for puncturing the control symbols. However, when the coded control symbol rate is lower than the given channel control symbol rate, the third rate matcher **1523** can be implemented by a repeater for repeating the control symbols to match the control symbol rate to the given channel control symbol rate. Alternatively, when the coded control symbol rate is lower than the given channel control symbol rate, the third rate matcher **1523** can be implemented by a repeater for repeating the control symbols to approximately match the control symbol rate to the given channel control symbol rate and a puncturer for matching a rate of the repeated control symbols to the given channel control symbol rate.

A multiplexer **1505** multiplexes the rate matched user data symbols and control data symbols. A rate of the multiplexed data is matched to a channel symbol rate at a channel rate matcher **1506**, and the rate matched symbol data is interleaved by a channel interleaver **1507**. A modulator **1508** modulates the channel interleaved symbol data. The modulator **1508** may employ CDMA modulation techniques. A transmitter **1509** converts the modulated transmission data to an RF signal and transmits the converter RF signal.

In this embodiment, when a rate of the symbols outputted from the multiplexer **1505** is higher than a given channel symbol rate, the channel rate matcher **1506** can be implemented by a puncturer for puncturing the symbols. However, when the rate of the symbols outputted from the multiplexer **1505** is lower than the given channel control symbol rate, the channel rate matcher **1506** can be implemented by a repeater for repeating the symbols to match the symbol rate to the given channel symbol rate. Alternatively, when the rate of the symbols outputted from the multiplexer **1505** is lower than the given channel symbol rate, the channel rate matcher **1506** can be implemented by a repeater for repeating the symbols to approximately match the symbol rate to the given channel symbol rate and a puncturer for matching a rate of the repeated symbols to the given channel symbol rate.

FIG. **16** is a block diagram illustrating a reception part for a communication system having the channel coder of FIG. **15**. Referring to FIG. **16**, a signal received via a transmission channel (or receiver) **1601** is demodulated by a demodulator **1602**. The demodulated data experiences symbol combination or insertion at a channel rate dematcher **1604** after channel deinterleaving at a channel deinterleaver **1603**, and the rate matched data is demultiplexed into first and second user data and control data by a demultiplexer **1605**. The first demultiplexed user data experiences symbol combination or insertion at a first rate dematcher **1606**, and a first channel decoder **1607** decodes the rate dematched user data. Since the decoded data includes the bits inserted by the first bit inserter **1502** of FIG. **15**, a first bit puncturer **1608** punctures the data bits as many as the number of the bits inserted by the first bit inserter **1502** of the transmission party. A first source decoder **1609** decodes the bit-punctured data to output the first user data.

Furthermore, the second demultiplexed user data experiences symbol combination or insertion at a second rate dematcher **1616**, and a second channel decoder **1617** decodes the rate dematched user data. Since the decoded

15

data includes the bits inserted by the second bit inserter **1512** of FIG. **15**, a second bit puncturer **1618** punctures the data bits as many as the number of the bits inserted by the second bit inserter **1512** of the transmission party. A second source decoder **1619** decodes the bit-punctured data to output the second user data.

Moreover, the demultiplexed control data experiences symbol combination or insertion at a third rate dematcher **1626**, and a third channel decoder **1627** decodes the rate dematched control data. A third source decoder **1628** decodes the decoded data outputted from the third channel decoder **1627** to output the control data. For the channel decoders **1607**, **1617** and **1627** of FIG. **16**, a Viterbi decoder can be used when a convolutional code is used and a soft-decision iterative decoder can be used when a turbo code is used.

The transmission schemes of FIGS. **9**, **11**, **13** and **15** include independent rate matchers for the user data and the control data. However, in FIG. **9**, for example, there is a case where only the first rate matcher **904** performs symbol puncturing while the second rate matcher **914** does not perform symbol puncturing. In this case, in the reception part of FIG. **10**, only the first rate dematcher **1005** operates while the second rate dematcher **1015** does not operate. On the contrary, in FIG. **9**, there is a case where only the second rate matcher **914** performs symbol puncturing while the first rate matcher **904** does not perform symbol puncturing. In this case, in the reception part of FIG. **10**, only the second rate dematcher **1015** operates while the first rate dematcher **1005** does not operate. Similarly, even in FIGS. **11**, **13** and **15**, it is contemplated that there may be cases where not all of the rate matchers perform rate matching simultaneously.

As described above, in accordance with the present invention, it is possible to minimize performance degradation of a mobile communication system during symbol repetition, puncturing and puncturing-after-symbol repetition in a rate matching device for facilitating implementation of hardware. Furthermore, since the reception party previously knows the inserted bits in the novel rate matching device, performance of the overall communication system increases as compared with a simple symbol repetition or puncturing-after-symbol repetition method where the reception party does not know the inserted bits.

In addition, with the present invention, it is possible to minimize performance degradation by puncturing the parity bits, not the data bits, when puncturing the coded symbols outputted from an RSC channel coder. Also, it is possible to minimize performance degradation by performing selective puncturing, such that the parity bits simultaneously generated by the respective constituent coders are not all punctured.

While the invention has been shown and described with reference to a certain preferred embodiments thereof, it will be understood by those skilled in the art that various changes in form and details may be made therein without departing from the spirit and scope of the invention as defined by the appended claims.

What is claimed is:

[1. A channel coding device comprising:

- a bit inserter for inserting known bits in an input data bit stream at predetermined positions;
- a channel coder for coding the bit-inserted data bit stream to generate coded symbols;
- a rate matcher for matching a rate of the coded symbols to a given channel symbol rate; and
- a channel interleaver for interleaving the rate matched channel symbols.]

16

[2. The channel coding device as claimed in claim 1, wherein the rate matcher comprises a puncturer for puncturing the inserted known bits included in the coded symbols when the coded symbol rate is higher than the given channel symbol rate.]

[3. The channel coding device as claimed in claim 2, wherein the puncturer punctures only parity symbols.]

[4. The channel coding device as claimed in claim 3, wherein the puncturer punctures only specific parity symbols outputted by the channel coder.]

[5. The channel coding device as claimed in claim 4, wherein the puncturer punctures only specific parity symbols such that the parity symbols are not consecutively punctured as many as the number of memories in a constituent coder for the channel coder.]

[6. The channel coding device as claimed in claim 4, wherein the puncturer selectively punctures only specific parity symbols such that not all of the parity symbols for a data bit are punctured.]

[7. The channel coding device as claimed in claim 1, wherein the rate matcher comprises a repeater for repeating the coded symbols to match the coded symbol rate to the given channel symbol rate when the coded symbol rate is lower than the given channel symbol rate.]

[8. The channel coding device as claimed in claim 1, wherein the rate matcher comprises:

a repeater for repeating the coded symbols to approximately match the coded symbol rate to the given channel symbol rate when the coded symbol rate is lower than the given channel symbol rate; and

a puncturer for puncturing the repeated symbols to match a rate of the repeated symbols to the given channel symbol rate.]

[9. The channel coding device as claimed in claim 8, wherein the puncturer punctures only parity symbols.]

[10. The channel coding device as claimed in claim 9, wherein the puncturer punctures only specific parity symbols outputted by the channel coder.]

[11. The channel coding device as claimed in claim 10, wherein the puncturer punctures only specific parity symbols such that the parity symbols are not consecutively punctured as many as the number of memories in a constituent coder for the channel coder.]

[12. The channel coding device as claimed in claim 10, wherein the puncturer selectively punctures only specific parity symbols such that not all of the parity symbols for a data bit are punctured.]

[13. A channel coding device comprising:

first bit inserters for inserting known bits in corresponding source user data bit streams at predetermined positions;

first channel coders for coding the bit-inserted user data bit streams to generate coded user symbols;

first rate matchers for matching a rate of the user symbols to a given channel user symbol rate;

a second bit inserter for inserting known bits in a source control data bit stream at predetermined positions;

a second channel coder for coding the bit-inserted control data bit stream to generate coded control symbols;

a second rate matcher for matching a rate of the control symbols to a given channel control symbol rate;

a multiplexer for multiplexing an output of the first rate matcher and an output of the second rate matcher;

a channel rate matcher for matching a rate of symbols outputted from the multiplexer to a given channel control symbol rate; and

17

a channel interleaver for interleaving output symbols of the channel rate matcher in a channel unit.]

[14. The channel coding device as claimed in claim 13, wherein the first rate matchers each comprise a puncturer for puncturing the user symbols when the user symbol rate is higher than the given channel user symbol rate.]

[15. The channel coding device as claimed in claim 13, wherein the first rate matchers each comprise a repeater for repeating the user symbols to match the user symbol rate to the given channel user symbol rate when the user symbol rate is lower than the given channel user symbol rate.]

[16. The channel coding device as claimed in claim 13, wherein the first rate matchers each comprise:

a repeater for repeating the user symbols to approximately match the user symbol rate to the given channel user symbol rate when the user symbol rate is lower than the given channel user symbol rate; and

a puncturer for puncturing the repeated user symbols to match a rate of the repeated user symbols to the given channel user symbol rate.]

[17. The channel coding device as claimed in claim 13, wherein the second rate matcher comprises a puncturer for puncturing the control symbols when the control symbol rate is higher than the given channel control symbol rate.]

[18. The channel coding device as claimed in claim 13, wherein the second rate matcher comprises a repeater for repeating the control symbols to match the control symbol rate to the given channel control symbol rate when the control symbol rate is lower than the given channel control symbol rate.]

[19. The channel coding device as claimed in claim 13, wherein the second rate matcher comprises:

a repeater for repeating the control symbols to approximately match the control symbol rate to the given channel control symbol rate when the control symbol rate is lower than the given channel control symbol rate; and

a puncturer for puncturing the repeated control symbols to match a rate of the repeated control symbols to the given channel control symbol rate.]

[20. The channel coding device as claimed in claim 13, wherein the channel rate matcher comprises a puncturer for puncturing symbols outputted from the multiplexer when a rate of the symbols outputted from the multiplexer is higher than the given channel symbol rate.]

[21. The channel coding device as claimed in claim 13, wherein the channel rate matcher comprises a repeater for repeating the symbols outputted from the multiplexer to match a symbol rate to the given channel symbol rate when the rate of the symbols outputted from the multiplexer is lower than the given channel symbol rate.]

[22. The channel coding device as claimed in claim 13, wherein the channel rate matcher comprises:

a repeater for repeating the symbols outputted from the multiplexer to approximately match a symbol rate to the given channel symbol rate when the rate of the symbols outputted from the multiplexer is lower than the given channel symbol rate; and

a puncturer for puncturing the repeated symbols to match a repeated symbol rate to the given channel symbol rate.]

[23. A channel coding device comprising:

first bit inserters for inserting known bits in corresponding source user data bit streams at predetermined positions;

first channel coders for coding the bit-inserted user data bit streams to generate coded user symbols;

first rate matchers for matching a rate of the user symbols to a given channel user symbol rate;

18

a second channel coder for coding a source control data bit stream to generate coded control symbols;

a second rate matcher for matching a rate of the control symbols to a given channel control symbol rate;

a multiplexer for multiplexing an output of the first rate matcher and an output of the second rate matcher;

a channel rate matcher for matching a rate of symbols outputted from the multiplexer to a given channel symbol rate; and

a channel interleaver for interleaving output symbols of the channel rate matcher in a channel unit.]

[24. The channel coding device as claimed in claim 23, wherein the first rate matchers each comprise a puncturer for puncturing the user symbols when the user symbol rate is higher than the given channel user symbol rate.]

[25. The channel coding device as claimed in claim 23, wherein the first rate matchers each comprise a repeater for repeating the user symbols to match the user symbol rate to the given channel user symbol rate when the user symbol rate is lower than the given channel user symbol rate.]

[26. The channel coding device as claimed in claim 23, wherein the first rate matchers each comprise:

a repeater for repeating the user symbols to approximately match the user symbol rate to the given channel user symbol rate when the user symbol rate is lower than the given channel user symbol rate; and

a puncturer for puncturing the repeated user symbols to match a repeated user symbol rate to the given channel user symbol rate.]

[27. The channel coding device as claimed in claim 23, wherein the second rate matcher comprises a puncturer for puncturing the control symbols when the control symbol rate is higher than the given channel control symbol rate.]

[28. The channel coding device as claimed in claim 23, wherein the second rate matcher comprises a repeater for repeating the control symbols to match the control symbol rate to the given channel control symbol rate when the control symbol rate is lower than the given channel control symbol rate.]

[29. The channel coding device as claimed in claim 23, wherein the second rate matcher comprises:

a repeater for repeating the control symbols to approximately match the control symbol rate to the given channel control symbol rate when the control symbol rate is lower than the given channel control symbol rate; and

a puncturer for puncturing the repeated control symbols to match a repeated control symbol rate to the given channel control symbol rate.]

[30. The channel coding device as claimed in claim 23, wherein the channel rate matcher comprises a puncturer for puncturing symbols outputted from the multiplexer when a rate of the symbols outputted from the multiplexer is higher than the given channel symbol rate.]

[31. The channel coding device as claimed in claim 23, wherein the channel rate matcher comprises a repeater for repeating the symbols outputted from the multiplexer to match the symbol rate to the given channel symbol rate when a rate of the symbols outputted from the multiplexer is lower than the given channel symbol rate.]

[32. The channel coding device as claimed in claim 23, wherein the channel rate matcher comprises:

a repeater for repeating the symbols outputted from the multiplexer to approximately match the symbol rate to the given channel symbol rate when a rate of the symbols outputted from the multiplexer is lower than the given channel symbol rate; and

19

a puncturer for puncturing the repeated symbols to match a repeated symbol rate to the given channel symbol rate.]

[33. A channel coding method comprising the steps of:
 inserting known bits in an input data bit stream at predetermined positions;
 coding the bit-inserted data bit stream to generate coded symbols;
 matching a rate of the coded symbols to a given channel symbol rate; and
 interleaving the rate matched channel symbols.]

[34. The channel coding method as claimed in claim 33, wherein the rate matching step comprises the step of puncturing the inserted known bits included in the coded symbols when the coded symbol rate is higher than the given channel symbol rate.]

[35. The channel coding method as claimed in claim 33, wherein the rate matching step comprises the step of repeating the coded symbols to match the coded symbol rate to the given channel symbol rate when the coded symbol rate is lower than the given channel symbol rate.]

[36. The channel coding method as claimed in claim 33, wherein the rate matching step comprises the steps of:

repeating the coded symbols to approximately match the coded symbol rate to the given channel symbol rate when the coded symbol rate is lower than the given channel symbol rate; and

puncturing the repeated symbols to match a repeated symbol rate to the given channel symbol rate.]

[37. A channel coding method comprising the steps of:
 inserting known bits in corresponding source user data bit streams at predetermined positions;

coding the bit-inserted user data bit streams to generate coded user symbols;

matching a rate of the user symbols to a given channel user symbol rate;

inserting known bits in a source control data bit stream at predetermined positions;

coding the bit-inserted control data bit stream to generate coded control symbols;

matching a rate of the control symbols to a given channel control symbol rate;

multiplexing an output of the first rate matcher and an output of the second rate matcher;

matching a rate of symbols outputted from the multiplexer to a given channel symbol rate; and

interleaving output symbols of the channel rate matcher in a channel unit.]

[38. A channel coding method comprising the steps of:
 inserting known bits in corresponding source user data bit streams at predetermined positions;

coding the bit-inserted user data bit streams to generate coded user symbols;

matching a rate of the user symbols to a given channel user symbol rate;

coding a source control data bit stream to generate coded control symbols;

matching a rate of the control symbols to a given channel control symbol rate;

multiplexing an output of the first rate matcher and an output of the second rate matcher;

matching a rate of symbols outputted from the multiplexer to a given channel symbol rate; and

20

interleaving output symbols of the channel rate matcher in a channel unit.]

39. A channel coding device comprising:

a bit inserter for inserting known bits in an input data bit stream at predetermined positions;

a channel coder for coding the bit-inserted data bit stream to generate coded symbols;

a rate matcher for matching a rate of the coded symbols to a given channel symbol rate; and

a channel interleaver for interleaving the rate matched channel symbols,

wherein the rate matcher comprises:

a repeater for repeating the coded symbols to match the rate of the coded symbols to the given channel symbol rate, when the coded symbol rate is lower than the given channel symbol rate; and

a puncturer for puncturing the coded symbols to match the rate of the coded symbols to the given channel symbol rate, when the coded symbol rate is higher than the given channel symbol rate.

40. A channel coding device comprising:

a bit inserter for inserting known bits in an input data bit stream at predetermined positions;

a turbo coder for turbo coding the bit-inserted data bit stream to generate coded symbols;

a rate matcher for matching a rate of the coded symbols to a given channel symbol rate; and

a channel interleaver for interleaving the rate matched channel symbols.

41. The channel coding method as claimed in claim 40, wherein the rate matcher comprises a repeater for repeating the coded symbols to match the coded symbol rate to the given channel symbol rate, when the coded symbol rate is less than the given channel symbol rate.

42. The channel coding device as claimed in claim 40, wherein the rate matcher comprises a puncturer for puncturing the inserted known bits included in the coded symbols when the coded symbol rate is greater than the given channel symbol rate.

43. The channel coding device as claimed in claim 40, wherein the rate matcher comprises a puncturer for puncturing parity symbols when the coded symbol rate is greater than the given channel symbol rate.

44. The channel coding device as claimed in claim 43, wherein the puncturer does not puncture data symbols.

45. The channel coding device as claimed in claim 43, wherein the puncturer punctures specific parity symbols such that the parity symbols are not consecutively punctured as many as the number of memories in a constituent coder for the turbo coder.

46. The channel coding device as claimed in claim 43, wherein the puncturer selectively punctures specific parity symbols such that not all of the parity symbols from a first constituent coder and a second constituent coder for a data bit are punctured.

47. The channel coding device as claimed in claim 40, wherein the rate matcher comprises:

a repeater for repeating the coded symbols to match the rate of the coded symbols to the given channel symbol rate when the coded symbol rate is less than the given channel symbol rate; and

a puncturer for puncturing the coded symbols to match the rate of the coded symbols to the given channel symbol rate when the coded symbol rate is greater than the given channel symbol rate.

21

48. The channel coding device as claimed in claim 47, wherein the puncturer punctures parity symbols.

49. The channel coding device as claimed in claim 48, wherein the puncturer does not puncture data symbols.

50. The channel coding device as claimed in claim 48, wherein the puncturer punctures specific parity symbols such that the parity symbols are not consecutively punctured as many as the number of memories in a constituent coder for the turbo coder.

51. The channel coding device as claimed in claim 48, wherein the puncturer selectively punctures specific parity symbols such that not all of the parity symbols from a first constituent coder and a second constituent coder for a data bit are punctured.

52. A channel coding method comprising the steps of: inserting known bits in an input data bit stream at predetermined positions;

turbo coding the bit-inserted data bit stream to generate coded symbols;

matching a rate of the coded symbols to a given channel symbol rate; and

interleaving the rate matched channel symbols.

53. The channel coding method as claimed in claim 52, wherein the rate matching step comprises the step of puncturing the inserted known bits included in the coded symbols, when the coded symbol rate is greater than the given channel symbol rate.

54. The channel coding method as claimed in claim 52, wherein the rate matching step comprises the step of puncturing parity symbols when the coded symbol rate is greater than the given channel symbol rate.

55. The channel coding method as claimed in claim 54, wherein data symbols are not punctured during the puncturing step.

56. The channel coding method as claimed in claim 54, wherein the puncturing step comprises the step of puncturing specific parity symbols such that the parity symbols are not consecutively punctured as many as the number of memories in a constituent coder for the turbo coder.

57. The channel coding method as claimed in claim 54, wherein the puncturing step comprises the step of punctur-

22

ing specific parity symbols such that not all of the parity symbols from a first constituent coder and a second constituent coder for a data bit are punctured.

58. The channel coding method as claimed in claim 52, wherein the rate matching step comprises the step of repeating the coded symbols to match the coded symbol rate to the given channel symbol rate, when the coded symbol rate is less than the given channel symbol rate.

59. The channel coding method as claimed in claim 54, wherein the rate matching step comprises the steps of: repeating the coded symbols to match the rate of the coded symbols to the given channel symbol rate, when the coded symbol rate is less than the given channel symbol rate; and

puncturing the coded symbols to match the rate of the coded symbols to the given channel symbol rate, when the coded symbol rate is greater than the given channel symbol rate.

60. The channel coding method as claimed in claim 59, wherein the puncturing step comprises the step of puncturing the inserted known bits included in the coded symbols, when the coded symbol rate is greater than the given channel symbol rate.

61. The channel coding method as claimed in claim 59, wherein the puncturing step comprises the step of puncturing parity symbols.

62. The channel coding method as claimed in claim 61, wherein data symbols are not punctured during the puncturing step.

63. The channel coding method as claimed in claim 61, wherein the puncturing step comprises the step of puncturing specific parity symbols such that the parity symbols are not consecutively punctured as many as the number of memories in a constituent coder for the turbo coder.

64. The channel coding method as claimed in claim 61, wherein the puncturing step comprises the step of puncturing specific parity symbols such that not all of the parity symbols from a first constituent coder and a second constituent coder for a data bit are punctured.

* * * * *