

(12) UK Patent Application (19) GB (11) 2 330 279 (13) A

(43) Date of A Publication 14.04.1999

(21) Application No 9721247.6	(51) INT CL ⁶ H04L 27/14
(22) Date of Filing 07.10.1997	(52) UK CL (Edition Q) H4P PAFS PAR
(71) Applicant(s) Ramar Technology Ltd (Incorporated in the United Kingdom) Airport House, Purley Way, CROYDON, Surrey, CRO 0XZ, United Kingdom	(56) Documents Cited EP 0651520 A2 EP 0409142 A2 WO 95/13675 A1 US 5483193 A US 4929851 A US 4897857 A
(72) Inventor(s) Terence George Giles	(58) Field of Search UK CL (Edition P) H4P PAFD PAFS PAR PDRP PDRX INT CL ⁶ H04L 7/04 12/56 27/14 27/156 ONLINE : WPI
(74) Agent and/or Address for Service Field Fisher Waterhouse 41 Vine Street, LONDON, EC3N 2AA, United Kingdom	

(54) Abstract Title
Low power density radio systems

(57) A low power density radio system is achieved using a simple FSK transmitter arranged to transmit very short bursts to a receiver at frequent intervals. Such a system can be used between a meter transponder and a reader in an AMR system to eliminate the need for a receiver in the transponder and still achieve extended battery life. The problems of detecting and demodulating the short burst may be overcome by the use of a sample and hold circuit that detects a preamble of reversals to indicate the presence of the burst and to provide the reference value to correct for the DC pedestal voltage (26) that arises as a function of the transmitter and receiver frequency errors.

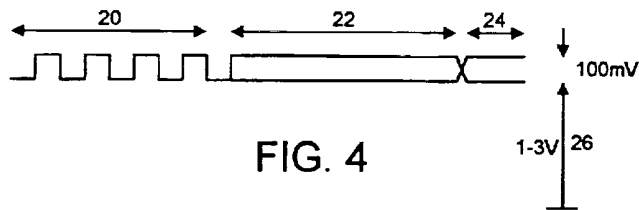

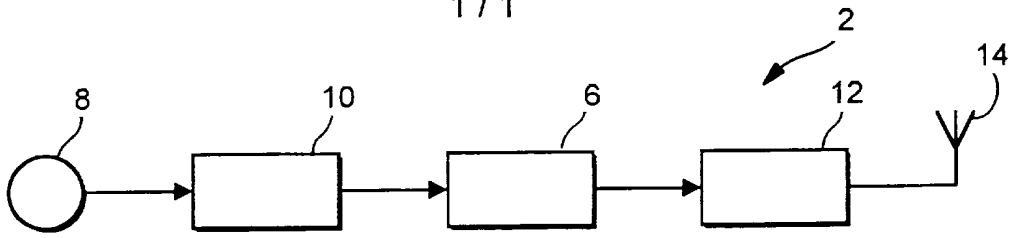

FIG. 1

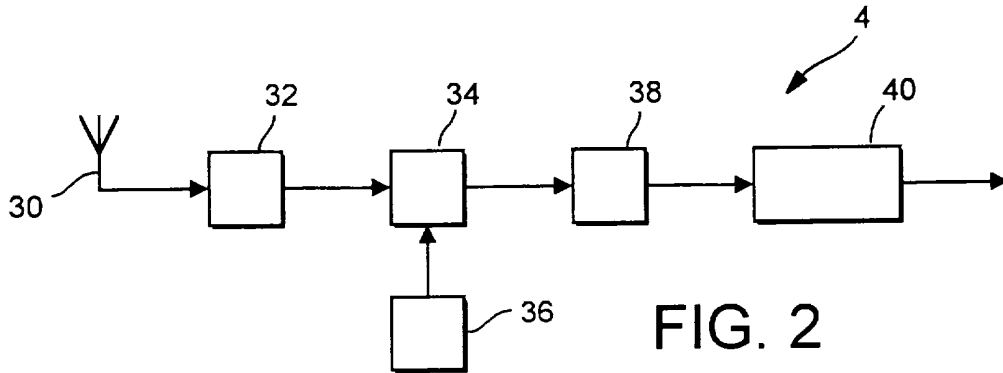

FIG. 2

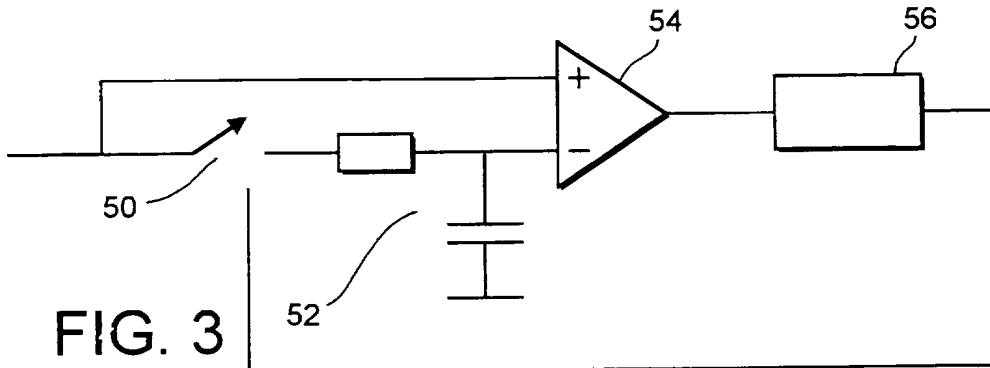

FIG. 3

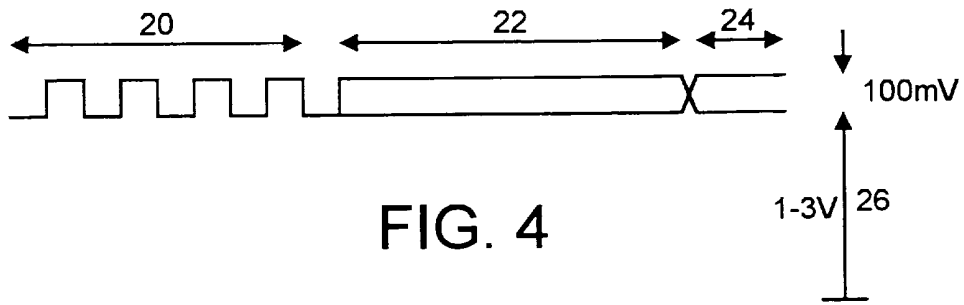

FIG. 4

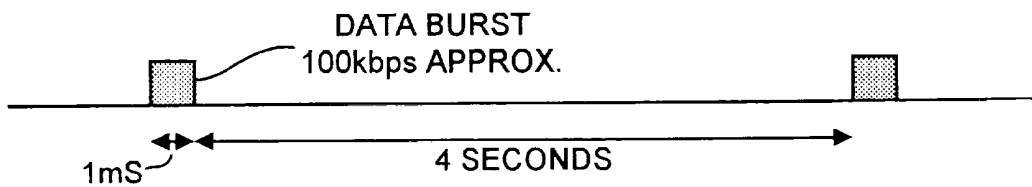

FIG. 5

LOW POWER DENSITY RADIO SYSTEMS

The present invention relates to low power density radio systems, and more specifically systems suitable for use in the first hop between a meter transponder and a receiver in an automatic meter reading (AMR) system. The system is also suitable for other applications.

The Technical Problem

Everywhere in the world it is difficult to find unused radio channels and this is particularly true for low power short range devices (SRD) which operate under licence exemption. In many countries, particularly the USA, the licensing authorities have encouraged the use of various types of spread spectrum modulation to allow uncoordinated sharing of channels. The normal methods of reducing the power density, and hence interference potential, on any channel is to use either frequency hopping (FH) or direct sequence spread spectrum (DSS).

Frequency hopping involves the transmitter jumping around a series of randomly selected narrow band channels with only a short time spent on any one frequency. For example the FCC Part 15.247 specifies a minimum of 50 channels with a maximum time of 0.4 seconds on any one channel in a 20 second period. In this way the average power density on any channel from a given transmitter is reduced to 2% of the power that would be present if it was not hopping. The alternative method, DSS, requires that the narrow band carrier is modulated by a high speed pseudo-random sequence which has the effect of spreading the signal over a wide band width. Again in FCC Part 15.247 the spreading gain is specified as a minimum of 20dB with a

minimum band width of 500kHz and so the average power density of a given transmitter is reduced to 1% or less.

The Solution of the Invention

The invention is a method of achieving the same reduction
5 in average power density by only occupying the target
channel for a very short time. In the proposed system the
transmission will only last 1mS and occur no more often
than every 4 seconds which represents an average power
density of only 0.025% compared with a continuous
10 transmission. In the past it has been technically
difficult to limit transmissions to only 1mS because of
problems of detecting that a signal is present, locking
on to it in a way that removes tuning errors and allows
the clock and then the data to be recovered. A method of
15 detecting the presence of the required signal and
removing the tuning errors is described below.

The Technical Problem for AMR

AMR is a low power, low cost radio system that allows
utility meters to be read from receivers in hand held or
20 mobile computers. A radio device normally referred to as
a transponder is attached to the meter so that it can
either count pulses or access the meter's internal
registers. The transponder is then interrogated i.e.
woken up by the reader and then sends the desired
25 information to the reader. The transponder can then go
back to sleep until the next interrogate sequence. The
major problem with this approach is the high cost both in
terms of components and power consumption of the receiver
in the transponder.

Low power density is particularly significant for AMR since the meter transponder is required to be low maintenance and reliable. For electricity meters there is no problem of power supply but for transponders for use
5 with water or gas or other non-electric utilities, it is generally necessary for the transponder to be battery powered so continuous power consumption has to be kept in the 10-20 μ A range. A low power density operation therefore enables long battery life.

10 Prior Art Solutions

The approach taken by most AMR systems for non-electric meters is to provide a transponder that responds to a wake-up signal and can therefore be powered down for long periods of time. The use of a wake-up signal requires the
15 transponder to have a receiver. This considerably increases the cost and complexity of the transponder. Prior art solutions also use spread spectrum as described to achieve low power density.

The AMR Solution of the Invention

20 Directly contrary to all the power saving teachings of the prior art, the present invention provides a low power density transmitter in the transponder that repeatedly transmits short data bursts containing the meter reading data. In this invention no receiver is needed but the
25 meter sends its short burst of data in a preferred embodiment every 4 seconds. The average current consumption of the meter radio transponder will be approximately 1/4000 of the peak transmitter current and means that the target battery consumption can be easily
30 achieved. This eliminates the need for a wake-up signal receiver. By suitable selection of the period between

bursts, it can be ensured that at least one burst will be present when the receiver is within range of the transponder. Because the low power density is achieved by the very short bursts it is not necessary to use spread spectrum solutions, further reducing the complexity of the transponder circuitry.

The detailed scope of the invention is defined in the appended claims.

Other Applications

10 The specific embodiment of the invention described relates to its use in an AMR transponder. However there are other possible applications for such a low power density radio systems. These include data transmissions from parking meters and traffic information data collection transponders on the roadside. Industrial uses in manufacturing and process control may also be found.

Brief Description of the Drawings

In order that the invention may be well understood an embodiment thereof will now be described, by way of example only, with reference to the accompanying diagrammatic drawings, in which:

Figure 1 is a block diagram of a transmitter for use in a transponder;

Figure 2 is a block diagram of a receiver;

25 Figure 3 is a diagram of a sample and hold circuit for use in the receiver to find the mid-point of the data.

Figure 4 is a diagram illustrating a data burst as transmitted; and

Figure 5 is a diagram showing the transmission pattern of data bursts when used in an AMR pseudo-interrogate mode.

Description of a Preferred Embodiment

A radio system comprises a transmitter 2 and receiver 4. The transmitter and receiver are conventional and designed for simplicity. A short burst transmitter 2 is based on a voltage controlled oscillator 6 such as a surface acoustic wave (SAW) oscillator or a phase locked loop (PLL) that can be directly modulated to produce FSK modulation.

As shown in Figure 1 the transmitter 2 is associated in this embodiment with a meter 8 that provides the data to be transmitted via a digital interface 10 which provides the modulation voltage input to the oscillator 6.

The output of the oscillator 6 is fed via a power amplifier 12 to a transmitter aerial 14.

Transmitter Modulation and Data Structure

The simplest method of sending the data from the meter 8 is by directly frequency modulating the transmitter carrier. Unfortunately the data could contain long periods of logic 1 or logic 0 and so the centre or slicing point of the data cannot be found by simple integration. The normal method of overcoming this problem is to use some form di-bit or Manchester encoding so that each data bit is represented by two bitlets where for example a logic 1 is coded as 01 and a logic 0 as 10. In

this way there will always be an equal number of 1s and 0s in the radio transmission so the slicing point can be found by integrating over a number of bits. The disadvantage is that for a given data rate the transmission will now take twice as long, as each data bit is represented by two modulation bits. Accordingly this problem of finding the centre or slicing point of the data in this embodiment is overcome by using a short burst data structure as shown in Figure 4. The first part of the burst is a preamble 20 consisting of, for example, 32 alternating 1s and 0s, then the data block 22 which is followed by a Cyclic Redundancy Check (CRC) 24, to allow the accuracy of the data to be verified.

Receiver

The receiver 4 as shown in Figure 2 is a simple single or multiple conversion superhet with a frequency discriminator. As shown a receiver aerial 30 feeds a signal to an RF amplifier 32 which supplies one input of a mixer 34 supplied by a local oscillator 36. An IF amplifier 38 selects the difference signal at the IF and feeds it to an FM discriminator 40. This type of receiver is essentially conventional.

A typical signal from the discriminator 40 is shown in Figure 4 and consists of a small AC signal of typically 100mV peak to peak corresponding to the transmitted burst previously described sitting on a DC pedestal voltage 26 of between 1 and 3V which will vary as a function of the transmitter and receiver frequency errors. In general the DC voltage 26 will be stable during a particular transmission but will be different for each individual transmitter and also vary with time and ambient temperatures.

This pedestal voltage 26 arises as a consequence of using simple direct frequency shift keying. Traditional methods of eliminating this variable pedestal are to either use very high stability oscillators in the transmitter and receiver, which is expensive, or to apply
5 some form of automatic frequency control (AFC). Unfortunately, with short bursts there is not sufficient time available for an AFC system to settle accurately.

The problem of detecting the signal and removing any
10 frequency errors is achieved by a novel sample and hold circuit in the demodulator as shown in Figure 3.

Sample and Hold Circuit

A sample and hold data discriminator is shown in Figure 3. It comprises a transmission gate switch 50, an RC
15 integrator 52, a comparator 54 and a shift register preamble detector 56. Initially in a first operating mode, the switch 50 will be closed and so the incoming signal will be integrated and applied to the comparator -ve input and will also be applied directly to the +ve
20 input of the comparator 54. The time constant of the integrator 52 is arranged to be about 4-8 bit periods long at the anticipated data rate. When no signal is present the integrated voltage will be a function of receiver output noise.

25 Any received preamble 20 will be integrated to its correct average value because of the equal population of 1s and 0s in the transmission. This means that accurate logic level preamble will appear out of the comparator 54 because the instantaneous signal applied to the
30 comparator +ve input will be compared with the accurate average on the -ve input. This eliminates the pedestal

voltage 26. The preamble detector 56 is arranged to sense say 16 bits of the reversals then it opens the sample gate switch 50. The detector now goes into a hold mode so that the accurate average voltage derived during the preamble is used as the comparator reference during the following data 22 and CRC 24. As the voltage is held from the preamble any asymmetry in the data or CRC can have no effect on the demodulator. At the end of the data burst the switch 50 is again closed and a new preamble acquisition is started.

This sample and hold circuit can readily be implemented in a relatively low cost ASIC chip making the receiver design cheap and compact and therefore suitable for hand-held reader applications.

15 AMR Application

For use in an AMR the data 22 can have any desired packet structure. In a pseudo interrogate mode this system can be used to replace transponders and readers that normally require an interrogate signal to wake-up the transponder. The data burst shown in Figure 4 can be transmitted once every 4 seconds as shown in Figure 5. The data burst lasts only 1 mS and carries data at approximately 100kbps.

The same radio system can also be used in slower modes with less frequent transmissions of longer data bursts. This is particularly suitable for simple fixed networks such as are required for sub water metering. It will be appreciated that the length and frequency of the bursts can be chosen in a suitable manner for the application in order to keep the power density within the required constraints.

CLAIMS

1. A low power density radio system comprising a transmitter and receiver, the transmitter comprising a digital data input for providing an intermittent short burst signal to an FSK modulator, and the receiver comprising means for detecting and demodulating said signal.
5
2. A radio system as claimed in claim 1, wherein the short burst includes a preamble having an equal number of 1s and 0s followed by data to be transmitted.
10
3. A radio system as claimed in claim 2, wherein the detecting means comprises a sample and hold circuit comprising a comparator having first and second inputs, and an integrator having an input and an output connected to a first said input of the comparator, which circuit is operable in a first mode wherein a demodulated signal is fed to both the integrator input and the second comparator input in order to detect the presence of said preamble, and a second hold mode in which the demodulated signal is fed to the second comparator input and the first input is held at the last integrated value to detect following data.
15
20
- 25 4. A receiverless transponder for use in an AMR system comprising a transmitter adapted to transmit short bursts of data at long intervals in order to achieve a low power density.
5. A low power density radio system substantially as herein described with reference to the accompanying drawings.
30

Amendments to the claims have been filed as follows

1. A low power density radio system comprising means for generating an intermittent short burst signal including a preamble having an equal number of 1s and 0s, the signal being of duration of the order of 5 1mS or less, a transmitter comprising an FSK modulator having an input terminal for receiving the signal produced by the generating means, and a receiver comprising means for detecting the average 10 signal level of the preamble of a received burst and comparing data levels in that burst with said average level.
2. A radio system as claimed in claim 1, wherein the detecting means comprises a sample and hold circuit comprising a comparator having first and second 15 inputs, and an integrator having an input and an output connected to a first said input of the comparator, which circuit is operable in a first mode wherein a demodulated signal is fed to both the integrator input and the second comparator input in order to detect the presence of said preamble, and a second hold mode in which the demodulated 20 signal is fed to the second comparator input and the first input is held at the last integrated value to detect following data.
3. A low power density radio system as claimed in claim 1 or 2 for use in an AMR system, wherein the short burst signal includes meter reading data and the signal is transmitted no more often than every 4 30 seconds in order to achieve a low power density.

4. A low power density radio system substantially as herein described with reference to the accompanying drawings.

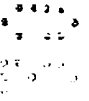



Application No: GB 9721247.6
Claims searched: 1 to 3 and 5

Examiner: Ken Long
Date of search: 26 January 1998

Patents Act 1977
Search Report under Section 17

Databases searched:

UK Patent Office collections, including GB, EP, WO & US patent specifications, in:
UK CI (Ed.P): H4P (PAR, PAFD, PAFS, PDRX & PDRP)
Int CI (Ed.6): H04L (27/14, 27/156, 12/56 & 7/04)
Other: ONLINE : WPI

Documents considered to be relevant:

Category	Identity of document and relevant passage	Relevant to claims
X	EP 0651520 A2 PLESSEY (whole document)	1 and 2
X	WO 95/13675 A1 PACIFIC (the last three lines of page 1, the last six lines of page 2 and lines 5-12 of page 3)	1 and 2
X	EP 0409142 A2 SANYO (column 1 lines 6-16 and column 1 line 50 to column 2 line 7)	1
X	US 5483193 FORD (column 1 line 47 to column 2 line 3 and column 2 lines 34-39)	1
X	US 4929851 MOTOROLA (column 1 lines 4-39 and column 3 lines 9-42)	1
X	US 4897857 MAN DESIGN (column 1 lines 14-22 and column 3 lines 12-44)	1 and 2

X Document indicating lack of novelty or inventive step
Y Document indicating lack of inventive step if combined with one or more other documents of same category.
& Member of the same patent family
A Document indicating technological background and/or state of the art.
P Document published on or after the declared priority date but before the filing date of this invention.
E Patent document published on or after, but with priority date earlier than, the filing date of this application.