

(19) World Intellectual Property Organization
International Bureau



(43) International Publication Date
2 February 2006 (02.02.2006)

PCT

(10) International Publication Number
WO 2006/012009 A2

(51) International Patent Classification:
A61F 9/007 (2006.01)

European (AT, BE, BG, CH, CY, CZ, DE, DK, EE, ES, FI, FR, GB, GR, HU, IE, IS, IT, LT, LU, MC, NL, PL, PT, RO, SE, SI, SK, TR), OAPI (BF, BJ, CF, CG, CI, CM, GA, GN, GQ, GW, ML, MR, NE, SN, TD, TG).

(21) International Application Number:
PCT/US2005/021123

Declarations under Rule 4.17:

(22) International Filing Date: 16 June 2005 (16.06.2005)

— as to applicant's entitlement to apply for and be granted a patent (Rule 4.17(ii)) for the following designations AE, AG, AL, AM, AT, AU, AZ, BA, BG, BR, BW, BY, BZ, CA, CH, CN, CO, CR, CU, CZ, DE, DK, DM, DZ, EC, EE, EG, ES, FI, GB, GD, GE, GH, GM, HR, HU, ID, IL, IN, IS, JP, KE, KG, KM, KP, KR, KZ, LC, LK, LR, LS, LT, LU, LV, MA, MD, MG, MK, MN, MW, MX, MZ, NA, NG, NI, NO, NZ, OM, PG, PH, PL, PT, RO, RU, SC, SD, SE, SG, SK, SL, SM, SY, TJ, TM, TN, TR, TT, TZ, UA, UG, UZ, VC, VN, YU, ZA, ZM, ZW, ARIPO patent (BW, GH, GM, KE, LS, MW, MZ, NA, SD, SL, SZ, TZ, UG, ZM, ZW), Eurasian patent (AM, AZ, BY, KG, KZ, MD, RU, TJ, TM), European patent (AT, BE, BG, CH, CY, CZ, DE, DK, EE, ES, FI, FR, GB, GR, HU, IE, IS, IT, LT, LU, MC, NL, PL, PT, RO, SE, SI, SK, TR), OAPI patent (BF, BJ, CF, CG, CI, CM, GA, GN, GQ, GW, ML, MR, NE, SN, TD, TG)

(25) Filing Language: English

(26) Publication Language: English

(30) Priority Data:
10/875,571 25 June 2004 (25.06.2004) US

(71) Applicant (for all designated States except BB, US):
OPTONOL, LTD [IL/IL]; Communication Center, Neve Ilan 90850 (IL).

(71) Applicant (for BB only): **HARDY, Josephine, B.**
[US/US]; 201 Eastern Parkway, Apt.4A, Brooklyn, NY 11238 (US).

(72) Inventors: **YARON, Ira**; 36 Haalon St., Har Adar 30836 (IL). **DAHAN, Elie**; 84 Troon Road, Greenside 2143, Johannesburg (ZA).

(74) Agents: **RINGEL, Douglas, E.** et al.; Kenyon & Kenyon, 1500 K Street, N.W., Suite 700, Washington, DC 20005 (US).

(81) Designated States (unless otherwise indicated, for every kind of national protection available): AE, AG, AL, AM, AT, AU, AZ, BA, BB, BG, BR, BW, BY, BZ, CA, CH, CN, CO, CR, CU, CZ, DE, DK, DM, DZ, EC, EE, EG, ES, FI, GB, GD, GE, GH, GM, HR, HU, ID, IL, IN, IS, JP, KE, KG, KM, KP, KR, KZ, LC, LK, LR, LS, LT, LU, LV, MA, MD, MG, MK, MN, MW, MX, MZ, NA, NG, NI, NO, NZ, OM, PG, PH, PL, PT, RO, RU, SC, SD, SE, SG, SK, SL, SM, SY, TJ, TM, TN, TR, TT, TZ, UA, UG, US, UZ, VC, VN, YU, ZA, ZM, ZW.

— as to the applicant's entitlement to claim the priority of the earlier application (Rule 4.17(iii)) for the following designations AE, AG, AL, AM, AT, AU, AZ, BA, BG, BR, BW, BY, BZ, CA, CH, CN, CO, CR, CU, CZ, DE, DK, DM, DZ, EC, EE, EG, ES, FI, GB, GD, GE, GH, GM, HR, HU, ID, IL, IN, IS, JP, KE, KG, KM, KP, KR, KZ, LC, LK, LR, LS, LT, LU, LV, MA, MD, MG, MK, MN, MW, MX, MZ, NA, NG, NI, NO, NZ, OM, PG, PH, PL, PT, RO, RU, SC, SD, SE, SG, SK, SL, SM, SY, TJ, TM, TN, TR, TT, TZ, UA, UG, UZ, VC, VN, YU, ZA, ZM, ZW, ARIPO patent (BW, GH, GM, KE, LS, MW, MZ, NA, SD, SL, SZ, TZ, UG, ZM, ZW), Eurasian patent (AM, AZ, BY, KG, KZ, MD, RU, TJ, TM), European patent (AT, BE, BG, CH, CY, CZ, DE, DK, EE, ES, FI, FR, GB, GR, HU, IE, IS, IT, LT, LU, MC, NL, PL, PT, RO, SE, SI, SK, TR), OAPI patent (BF, BJ, CF, CG, CI, CM, GA, GN, GQ, GW, ML, MR, NE, SN, TD, TG)

Published:

— without international search report and to be republished upon receipt of that report

(84) Designated States (unless otherwise indicated, for every kind of regional protection available): ARIPO (BW, GH, GM, KE, LS, MW, MZ, NA, SD, SL, SZ, TZ, UG, ZM, ZW), Eurasian (AM, AZ, BY, KG, KZ, MD, RU, TJ, TM),

For two-letter codes and other abbreviations, refer to the "Guidance Notes on Codes and Abbreviations" appearing at the beginning of each regular issue of the PCT Gazette.

(54) Title: FLOW REGULATING IMPLANTS

(57) Abstract: A flow regulating implant is provided with one or more grooves for allowing fluid flow. One or more grooves may have a constant or varying cross-section along its length. One or more grooves may have in it biodegradable material, absorbable material, and/or threads or sutures. A resilient band or coating may be placed around the implant or one or more grooves, to act as a pressure regulator. The implant may have a side projection, such as a side pin, for engaging tissue. The implant may comprise two or more parts that are held at a distance from each other to allow fluid flow between the parts.

WO 2006/012009 A2

FLOW REGULATING IMPLANTS

FIELD OF THE INVENTION

[0001] The invention relates generally to flow regulating implants, for example
5 ophthalmic implants for treatment of glaucoma.

BACKGROUND OF THE INVENTION

[0002] U.S. Patent No. 5,868,697 discloses devices and methods for regulating
fluid flow. The devices and methods are useful, for example, in the treatment of
10 glaucoma, by providing for the flow of aqueous humor from the eye to reduce
intraocular pressure (IOP). The devices and methods disclosed in that patent are
expressly incorporated by reference into this specification.

[0003] As with the devices and methods disclosed in U.S. Patent No. 5,868,697,
the devices and methods disclosed herein are also for regulating fluid flow. The
15 devices and methods disclosed herein are useful, for example, in the treatment of
glaucoma, by providing for the flow of aqueous humor from the eye to reduce
intraocular pressure (IOP).

SUMMARY OF THE INVENTION

20 [0004] In certain embodiments, the invention is directed to an improved flow
regulating implant that has one or more grooves for allowing fluid flow.

[0005] In certain embodiments, one or more grooves may have a constant cross-
section along its length.

[0006] In certain embodiments, one or more grooves may have a varying cross-
25 section along its length. For example, one or more grooves may be tapered, as a
funnel. The wider end may be at the inlet end or the outlet end.

[0007] In certain embodiments, one or more grooves may have in it
biodegradable material, absorbable material, and/or threads or sutures.

[0008] In certain embodiments, a resilient band or coating may be placed around
30 the implant or one or more grooves, to act as a pressure regulator.

[0009] In certain embodiments, in addition to one or more grooves, the implant
may have a tube passage running through it. The tube passage may have in it
biodegradable material, absorbable material, and/or threads or sutures.

[00010] In certain embodiments, the implant may have a side projection, such as a side pin, for engaging tissue. The side projection or pin may be useful for resisting rotation and/or firmly holding the implant within the tissue.

[00011] In certain embodiments, the implant may comprise two or more parts that
5 are held at a distance from each other to allow fluid flow between the parts.

BRIEF DESCRIPTION OF THE DRAWINGS

[00012] FIG. 1 is a perspective view of a first embodiment of a flow regulating
implant;

10 [00013] FIG. 2 is an alternative perspective view of the flow regulating implant of
FIG. 1;

[00014] FIG. 3 is an alternative perspective view of the flow regulating implant of
FIG. 1;

[00015] FIG. 4 is a perspective view of the flow regulating implant of FIG. 1,
15 with material in the side grooves;

[00016] FIG. 5 is a perspective view of the flow regulating implant of FIG. 1,
with threads or sutures in the side grooves;

[00017] FIG. 6 is a perspective view of the flow regulating implant of FIG. 1,
with a flow regulating band or coating around the implant;

20 [00018] FIG. 7 is a perspective view of an alternative embodiment of a flow
regulating implant with side grooves, with holes at the outlet ends of the grooves;

[00019] FIG. 8 is a perspective view of another alternative embodiment of a flow
regulating implant with side grooves, with a hole in the flange at the outlet end of
the implant;

25 [00020] FIG. 9 is a perspective view of an alternative embodiment of a flow
regulating implant with side grooves, with an alternative flange design at the outlet
end of the implant;

[00021] FIG. 10 is a perspective view of an alternative embodiment of a flow
regulating implant with side grooves, with a tube passage running through the
30 implant;

[00022] FIG. 11 is a perspective view of the flow regulating implant of FIG. 10,
with a thread or suture in the tube passage;

[00023] FIG. 12 is a perspective view of an alternative embodiment of a flow regulating implant, with a side pin;

[00024] FIG. 13 is a perspective view of an alternative embodiment of a flow regulating implant, comprising two parts that are held at a distance from each other
5 to allow fluid flow between the parts;

[00025] FIG. 14 is a perspective view of an alternative embodiment of a flow regulating implant, comprising two parts that are held at a distance from each other to allow fluid flow between the parts, wherein the two parts may be pushed together or moved apart.

10

DETAILED DESCRIPTION

[00026] FIGS. 1 to 3 illustrate a first embodiment of a flow regulating implant. The illustrated implant is in the form of an intraocular implant 10. The implant 10 comprises a shaft 11 and a flange (or plate or disk) 12. The cross-section of the shaft may take any suitable shape, for example square, rectangular, ellipsoidal,
15 circular, or an irregular shape. In this illustrated embodiment, the plane of the flange 12 forms an angle with the shaft 11 that corresponds generally to the angle between the surface of the sclera of an eye and the intended axis of insertion of the implant 10. The flange 12 limits the depth of insertion and stabilizes the device. The
20 angling of the flange 12 helps limit or prevent rotation of the device. In certain applications, it may be desired to remove the device, in which case the flange may be used for that purpose.

[00027] The implant 10 has an inlet end 13 and an outlet end 14. The flange 12 is connected to the shaft 11 at the outlet end 14 of the implant 10. The implant 10 may
25 have one or more retention projections 15 for retaining the implant 10 after insertion. The retention projection(s) 15 may take any suitable form.

[00028] In the illustrated embodiment, the shaft 11 has a rounded tip at the inlet end 13 of the implant 10. It will be appreciated that the tip may take other suitable forms. For example, the tip may be a needle-like tip formed by a beveled surface,
30 angled sharply for easy insertion into the eyeball.

[00029] The implant 10 has two side grooves 16A, 16B. In the illustrated embodiment, the side grooves 16A, 16B extend the full length of the implant 10,

from the inlet end 13 to the outlet end 14. The side grooves 16A, 16B are in the side of the shaft 11 and extend through the flange 12.

[00030] An implant in accordance with the invention may be inserted by methods disclosed in U.S. Patent No. 5,868,697, incorporated herein by reference. The
5 insertion of the implant is not restricted to those methods. In certain instances, it may be desirable to implant the device such that the flange is located under scleral flap, i.e., a flap of tissue cut from the sclera. In such a method, a scleral flap is carefully cut from the sclera. The cut is preferably not made all the way through the sclera to the anterior chamber. Rather, the cut extends only part way through, to
10 create the scleral flap that can be moved away to expose a place for insertion of the implant. With the scleral flap lifted, the implant is inserted in the intended implantation site, with the flange under the scleral flap. The implantation of the device under a scleral flap may assist in absorption of fluid. It also may assist in retention of the device.

[00031] With the device as illustrated in FIGS. 1 to 3, in operation, the grooves 16A, 16B form passageways for fluid to flow from the inlet end 13 toward the outlet end 14 of the implant 10. In the case of an intraocular implant, the aqueous humor in the eye can flow along the grooves from the inlet end 13 toward the outlet end 14.

[00032] The grooves 16A, 16B are directly adjacent the tissue into which the
20 implant 10 is implanted. Thus, for example, the scleral tissue of the eye will surround the implant. In this manner, the scleral tissue can function as a valve to control the flow of fluid out of the eye. When the pressure in the anterior chamber is low, the tissue is close around the implant and in the grooves to block or limit the flow of fluid along the grooves. When the pressure in the anterior chamber is
25 elevated, the fluid exerts pressure on the tissue to clear the passageway along the grooves, and fluid will flow along the grooves between the implant device and the tissue.

[00033] With the grooves, the aqueous humor flowing out of the anterior chamber is allowed to directly contact the scleral tissue, which allows for direct absorption of
30 the aqueous humor by the sclera. The fluid may be absorbed by the sclera or may flow out, for example underneath the conjunctiva.

[00034] The groove(s) may take any suitable form. For example, one or more grooves may be shaped as a funnel, tapering from one end to the other. The wider

end may be at the outlet end or the inlet end, depending on the desired application. Other modifications to the size, shape, and/or cross-sectional configuration of the groove(s) may be made.

[00035] It will be appreciated that in addition to the flow regulation
5 characteristics, the grooves may serve the additional benefit of limiting or preventing rotation of the device. It will also be appreciated that non-circular cross-sections for the shaft will also help limit or prevent rotation of the device. For example, a cross-section having corners, like a square, rectangular or other polygonal cross-section, will help limit or prevent rotation. In addition, a cross-
10 section with different dimensions in different direction, like an elliptical or rectangular cross-section, will help limit or prevent rotation. The grooves may help to limit or prevent rotation even with an otherwise circular cross-section for the shaft. The tissue in the gutters may help hold the position of the device.

[00036] FIG. 4 illustrates the flow regulating implant of FIG. 1, with material 17
15 in the side grooves. In this example, the material 17 may be a biodegradable material, an absorbable material, or a material that may be ablated with a laser. Such materials may act to block or limit flow initially and to allow more flow over time. For example, a physician may ablate the laser-ablatable material at some period of time after implantation, or in increments over time. The biodegradable or
20 absorbable material may act to block flow upon initial implantation and to erode or degrade over time to allow more flow. Further descriptions of the use of such materials in flow regulating implants are provided in U.S. Patent Nos. 6,203,513 and 6,558,342, the disclosures of which are incorporated herein by reference.

[00037] FIG. 5 illustrates the flow regulating implant of FIG. 1, with threads or
25 sutures 18 in the side grooves. The threads or sutures 18 may act to block or limit flow initially and to allow more flow over time. For example, a physician may remove the threads or sutures 18 at some period of time after implantation, or may remove one at a time in increments over time. It will be appreciated that more than one thread or suture 18 may be placed in each groove. Further descriptions of the
30 use of threads or sutures in flow regulating implants are provided in U.S. Patent No. 6,558,342, the disclosure of which is incorporated herein by reference.

[00038] FIG. 6 illustrates the flow regulating implant of FIG. 1, with a flow regulating band or coating 19 around the implant. The band or coating 19 may

extend over only part of the length of the implant, as illustrated, or, alternatively, it may extend over the full length of the implant. The band or coating 19 may be shaped to extend into the grooves. The band or coating 19 is resilient and acts as valve to control the flow of fluid out of the eye. When the pressure in the anterior chamber is low, the band or coating 19 is close around the implant and in the grooves to block or limit the flow of fluid along the grooves. When the pressure in the anterior chamber is elevated, the fluid exerts pressure on the band or coating 19 to clear the passageway along the grooves, and fluid will flow along the grooves between the implant shaft and the band or coating 19.

10 [00039] FIG. 7 illustrates another embodiment of a flow regulating implant. This flow regulating implant 20 is similar to the flow regulating implant 10. The flow regulating implant 20 has a shaft 21, a flange 22, and grooves 26A, 26B (groove 26B not shown). In this embodiment, the flange has holes 27A, 27B in it at the outlet ends of the grooves 26A, 26B, respectively. These holes allow the flow of fluid away from the implant.

15 [00040] FIG. 8 illustrates another embodiment of a flow regulating implant. This flow regulating implant 30 is similar to the flow regulating implants described above. The flow regulating implant 30 has a shaft 31, a flange 32, and grooves 36A, 36B. In this embodiment, the flange has a hole 38 in it. With this hole, a suture may be used to attach the implant to tissue to fix it in place.

20 [00041] FIG. 9 illustrates a flow regulating implant 40. This flow regulating implant 40 is similar to the flow regulating implants described above. The flow regulating implant 40 has a shaft 41, a flange 42, and grooves 46A, 46B. In this embodiment, the flange 42 has a different shape, which may be useful in certain applications.

25 [00042] FIG. 10 is a perspective view of an alternative embodiment of a flow regulating implant with side grooves. The implant 50 has tube passage 51 running through the implant. This tube passage 51 provides an additional passageway for fluid flow. The tube passage may have in it absorbable, biodegradable, laser-ablatable and/or removable material for blocking or partially obstructing fluid flow, and for allowing further flow over time. FIG. 11 illustrates the flow regulating implant of FIG. 10, with a thread or suture 58 in the tube passage 51.

[00043] FIG. 12 is a perspective view of an alternative embodiment of a flow regulating implant 60, with a side projection in the form of a side pin 68. Upon implantation, the pin 68 is fixed in the scleral tissue and serves to resist rotation of the device. The pin 68 may also assist in holding the device in the sclera, providing a sealing of the sclera around the shaft of the implant to prevent undesired leakage. The pin also fixes the device to prevent the possibility of the device pressing on and eroding the conjunctiva.

[00044] The projection or pin could be made of any suitable material, and it could be removable or changeable. For example, the projection or pin could be made of absorbable, biodegradable, laser-ablatable and/or removable material. The projection or pin 68 could be movable with a hole in the shaft 61, so that its length of projection from the shaft 61 could be adjustable. Also, a slot or other holes could be provided to allow adjustment of the positioning of the projection or pin.

[00045] FIG. 13 is a perspective view of an alternative embodiment of a flow regulating implant. The implant 70 comprises two parts 71, 72 that are held at a distance from each other to allow fluid flow between the parts. In implant 70, the two parts 71, 72 are joined to each other by two cylinders 73A, 73B. The implant may be formed as one piece, or the parts may be joined by any suitable means, for example welding. The two parts 71, 72 may be joined by just one cylinder or by parts of other shapes, for example, one or more spheres. Alternatively, the two parts may be shaped to be joined directly together with a space between them. It will be appreciated that the space 74 between the parts 71, 72 provides a space for the flow of fluid and allows further fluid contact with the sclera.

[00046] FIG. 14 illustrates a flow regulating implant 80 comprising two parts 81, 82 that are formed together as parts of a single, one-piece device. It will be appreciated that the space 84 between the parts 81, 82 provides a space for the flow of fluid and allows further fluid contact with the sclera, similar to the implant 70. The two parts 81, 82 may be pushed together or moved apart, which can control the spacing and thus the fluid flow.

[00047] An implant constructed in accordance with the invention may be manufactured entirely from or covered with any suitable material, such as stainless steel, silicon, gold, nitinol, Teflon, tantalum, PMMA, or any other suitable metallic or polymeric or other material. The entire device may be made from a degradable

material. The device may be made by molding or any other suitable method of manufacture. The device may be manufactured as one piece or as separate pieces that are joined together. The implant may be coated with heparin or any other suitable coating.

5 [00048] Implants in accordance with the invention may be provided with other features and/or implanted with delivery devices and/or by other methods, for example those disclosed in U.S. Patent Nos. 5,868,697; 6,203,513 and 6,558,342, discussed above.

10 [00049] As will be appreciated by persons having ordinary skill in the art, the various embodiments of implants described hereinabove are given by way of example only. Various changes, modifications and variations may be applied to the described embodiments without departing from the scope of the invention, defined by the appended claims.

CLAIMS

1. An implant for regulating fluid flow, the implant comprising a shaft and a flange, the implant having an inlet end and an outlet end, wherein the implant comprises one or more grooves in the side of the shaft for enabling fluid
5 flow.
2. The implant of claim 1, wherein the cross section of at least one groove is constant along its length.
- 10 3. The implant of claim 1, wherein at least one groove is tapered.
4. The implant of claim 1, further comprising removable material located in at least one groove.
- 15 5. The implant of claim 4, wherein the removable material is a laser-ablatable materials.
6. The implant of claim 4, wherein the removable material is a removable thread or suture.
- 20 7. The implant of claim 1, further comprising a degradable material located in at least one groove.
8. The implant of claim 1, further comprising an absorbable material located in
25 at least one groove.
9. The implant of claim 1, further comprising a resilient band or coating covering at least a portion of at least one groove.
- 30 10. The implant of claim 1, further comprising a projection extending from the side of the shaft for anchoring the implant within tissue.
11. The implant of claim 1, wherein the cross-section of the shaft is non-circular.

12. An implant for regulating fluid flow, the implant comprising a first part and a second part, wherein the first part is spaced from the second part, and wherein a space is located between the first part and second part for enabling fluid flow.
- 5
13. The implant of claim 12, wherein the first part and second part are joined to each other by an additional piece.
- 10 14. The implant of claim 12, wherein the first part and second part are formed together as parts of a single, one-piece implant.

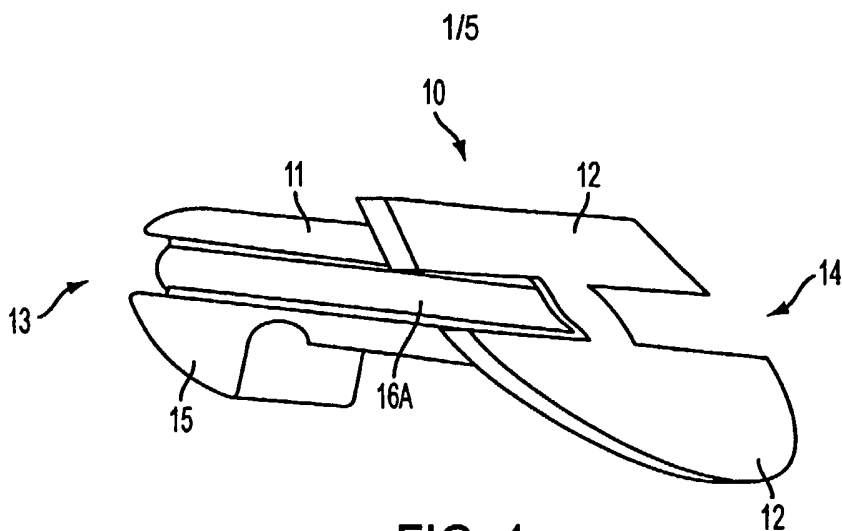

FIG. 1

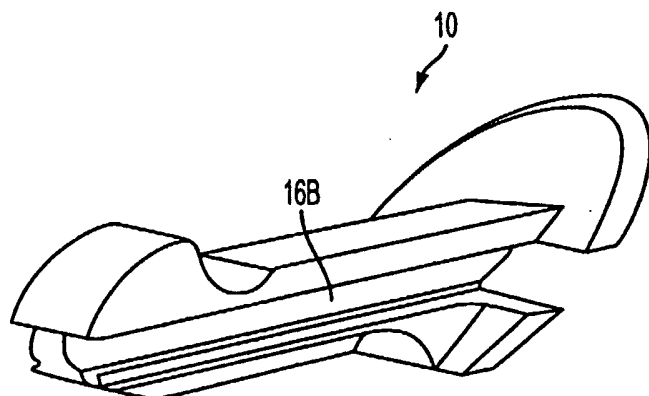

FIG. 2

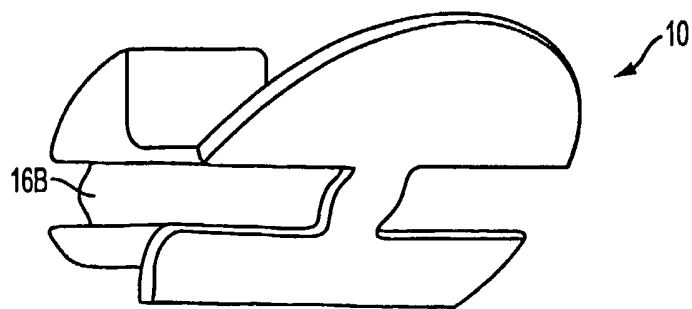

FIG. 3

2/5

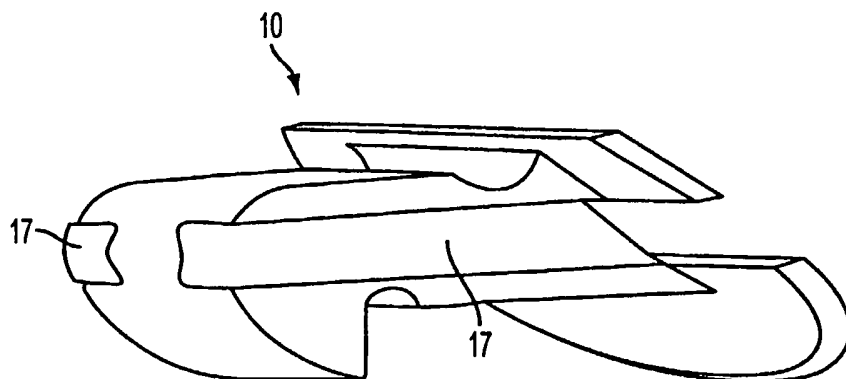

FIG. 4

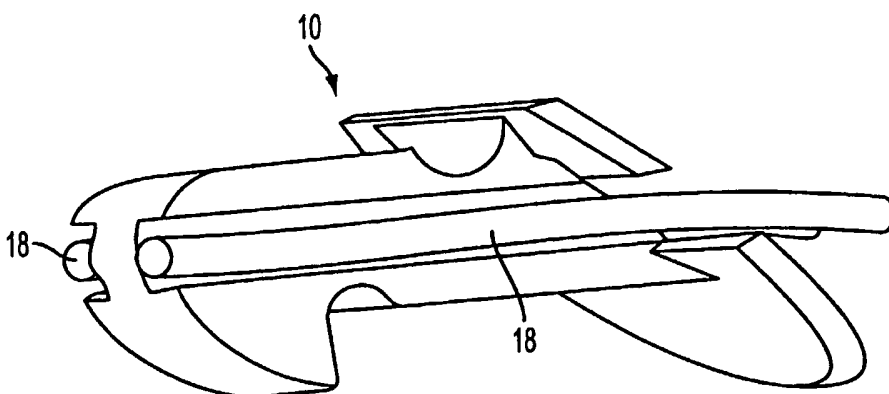

FIG. 5

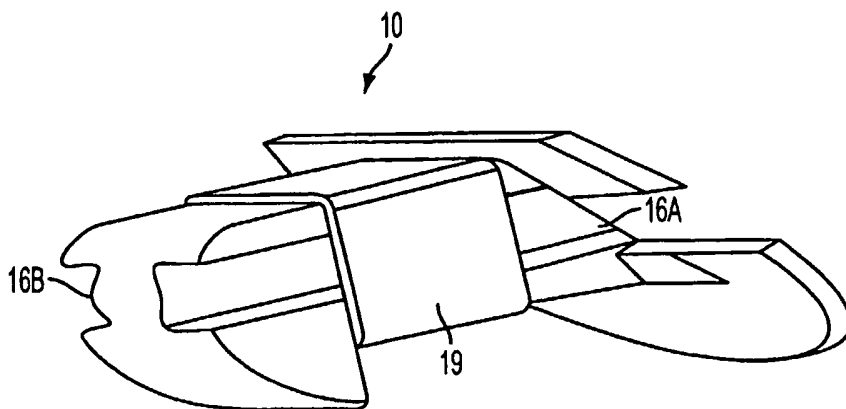

FIG. 6

3/5

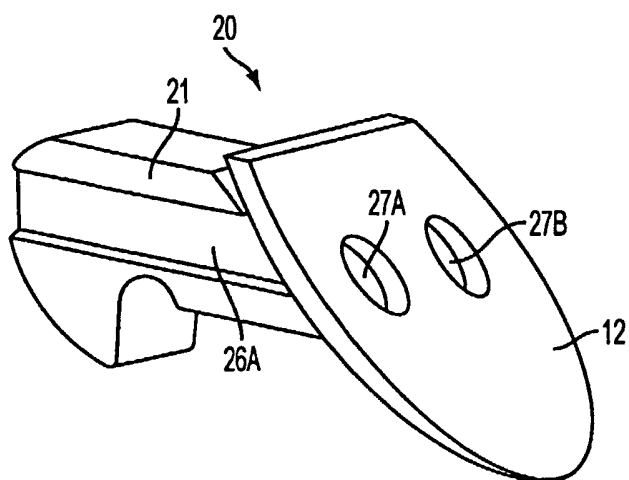

FIG. 7

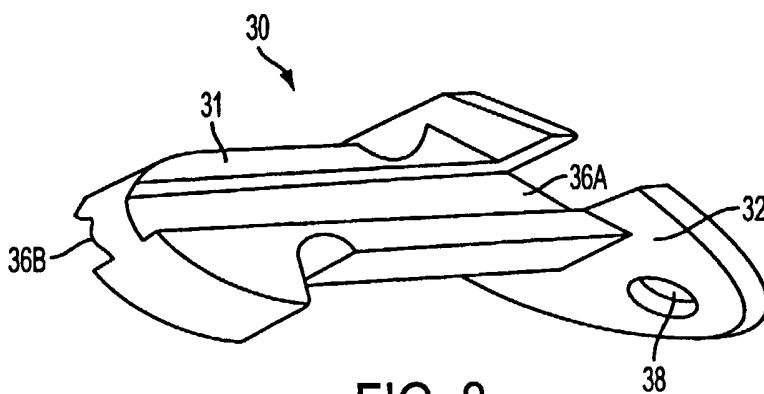

FIG. 8

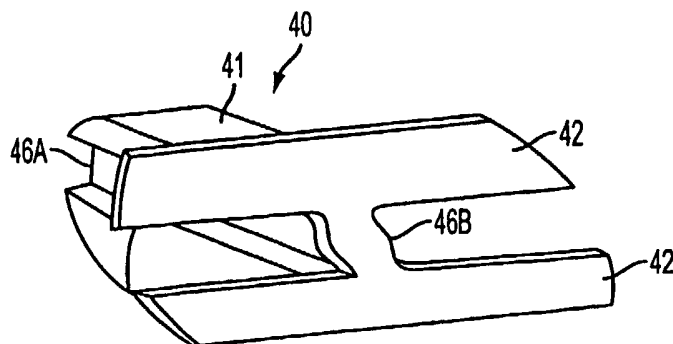

FIG. 9

4/5

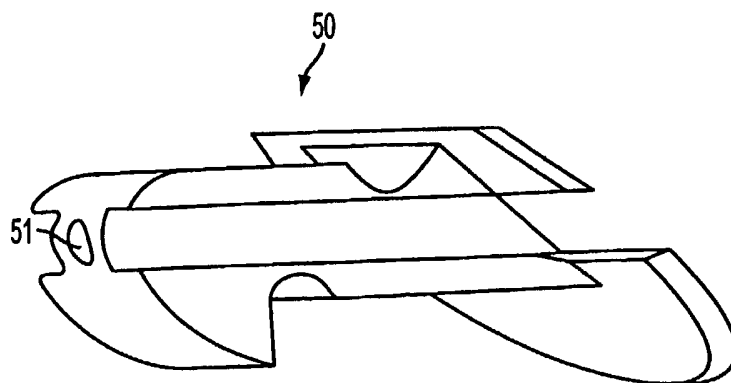

FIG. 10

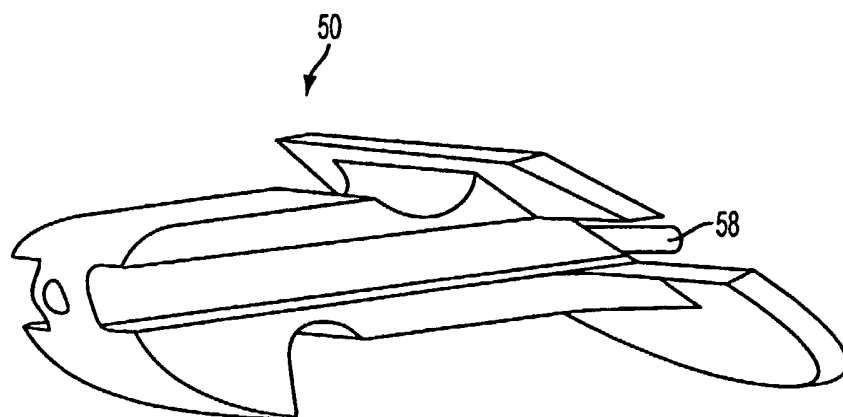

FIG. 11

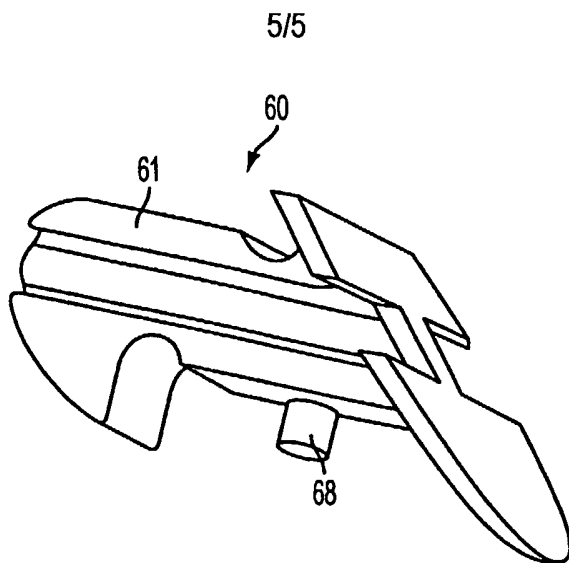

FIG. 12

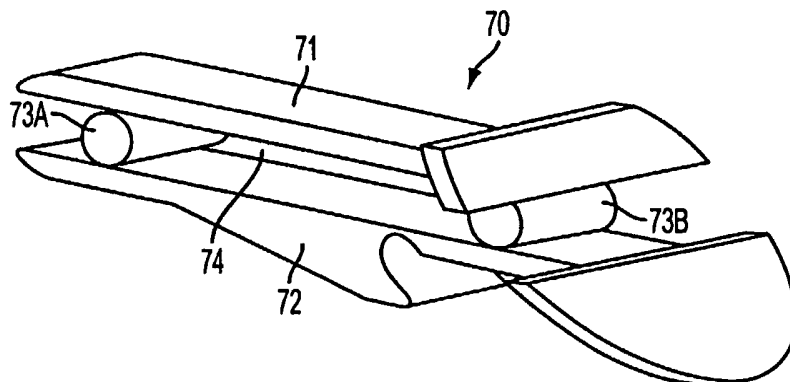

FIG. 13

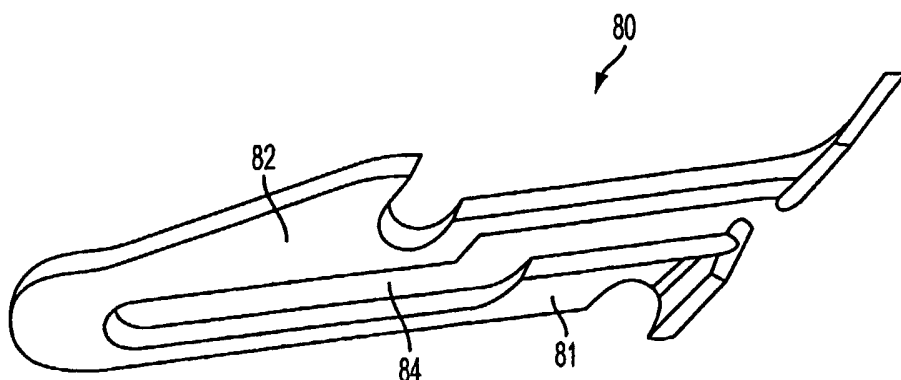

FIG. 14