

(No Model.)

J. J. GREEN.  
TROLLEY WIRE HANGER.

No. 526,704.

Patented Oct. 2, 1894.

Fig. 1

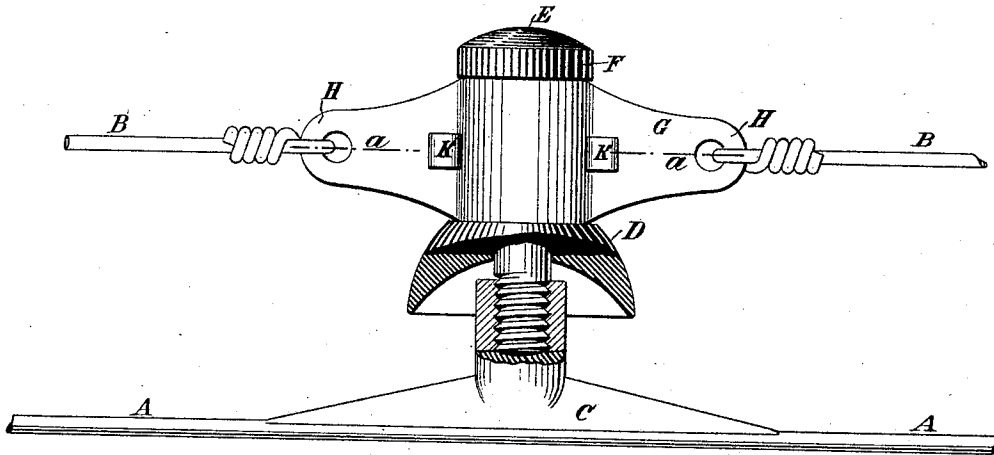

Fig. 2

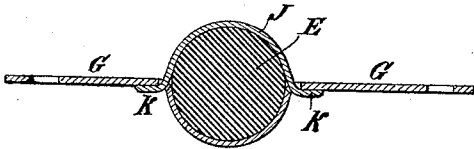

Fig. 3

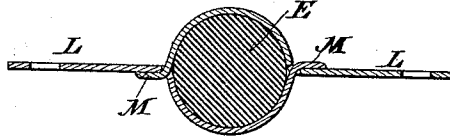

Fig. 4

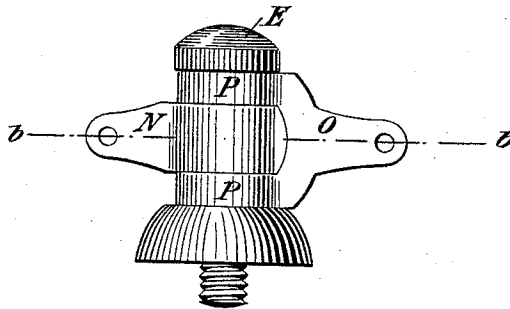
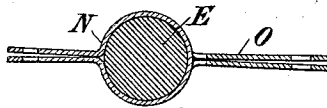

Fig. 5



Witnesses:

*Franz Netter*  
*James W. Catlow*

Inventor  
*John J. Green*  
by *Duncan & Page*  
Attorneys.

# UNITED STATES PATENT OFFICE.

JOHN J. GREEN, OF BOONTON, NEW JERSEY, ASSIGNOR TO THE LOAN DO  
HARD RUBBER COMPANY, OF SAME PLACE.

## TROLLEY-WIRE HANGER.

SPECIFICATION forming part of Letters Patent No. 526,704, dated October 2, 1894.

Application filed June 4, 1894. Serial No. 513,347. (No model.)

*To all whom it may concern:*

Be it known that I, JOHN J. GREEN, a citizen of the United States, residing at Boonton, in the county of Morris and State of New Jersey, have invented certain new and useful Improvements in Trolley-Wire Hangers, of which the following is a specification, reference being had to the drawings accompanying and forming a part of the same.

The present improvements relate to devices for supporting the trolley-wire of an electric railway.

The essential feature of the improvements relates to the device by which the said trolley wire supporting mechanism is suspended by hanger or stretcher wires extending laterally across the path of the railway to posts or other supports; and the essential feature of the improvements consists of devices for supporting the said mechanism which are made from sheet metal, struck-up (in distinction to devices made by casting), and composed of interlocking or conjointly locking parts.

I will first describe the said improvements, and in the claims to follow the description I will point out what I regard as new and of my invention.

In the drawings accompanying this specification Figure 1 is a general elevational view of a section of a trolley wire and of a device for supporting the same, the lateral hanger or stretcher wires that support the trolley wire being shown as apparently in the same plane with the trolley wire, for the purpose of conveniently illustrating the features of this invention. Fig. 2 is a horizontal section of these parts on the line *aa* of Fig. 1; and Fig. 3 shows a similar section of a modified form of the suspending mechanism. Fig. 4 shows another modification in side view or elevation, and Fig. 5 is a section of the same on the plane *bb* of Fig. 4.

Referring to the views in detail A represents the trolley wire. B represents the hanger or stretcher wires which support the trolley wire and which are usually arranged at right angles, or substantially so, to the direction of the trolley wire.

C is the foot or ear-piece which is attached to the trolley wire and carries a screw socket or other means of attachment to the screw

shank of the insulating bell D. This bell has a neck extension E, at the top of which is the laterally projecting head F. All of this bell, and its neck and head, may be of insulating material, which parts as shown in the drawings are well known in this art.

The device for supporting the insulating bell consists (see Fig. 1) of a strip or plate of sheet metal G, which is shaped midway of its length to partially surround the neck of the bell and has at each end an eye or socket H or other equivalent device adapted to engage with the laterally extending or side stretcher wire or wires B, as shown in said Fig. 1.

J is a strip or plate cut from sheet metal and bent into proper form corresponding to the size and shape of the neck of the insulating bell and which is provided with the ears K, which are passed through holes in the plate G and are bent over and may be riveted upon the same, particularly as shown in Fig. 1.

In lieu of the combination of plate G and the back plate J being made as shown in Fig. 1, these parts may be of two pieces cut from sheet metal and of substantially the form indicated in Fig. 3, in which these parts are shown as made in substantially duplicate form, but reversely applied to the neck of the hanger bell. Here each plate L is provided with a single ear M engaging the extension or hanger part of the other, as do the ears K of Fig. 1.

In Fig. 4 is shown another form of this hanger mechanism where N represents a strap or plate bent around the middle of the hanger bell neck, its two ends being brought together, see Fig. 5, and forming means of attachment to one of the supporting wires. A forked plate O having the two straps P and surrounding the bell neck above and below the plate N is arranged upon the other side of the said neck and its free ends are brought together, Fig. 5, and constitute the means of attachment to the opposite supporting wire.

I am aware that the supporting mechanism of trolley wires has heretofore been made of castings of various forms and shapes adapted to engage the insulating bell, and adapted to engage or be attached to laterally extending hanger or stretcher wires. In all such cast devices, so far as I am informed, excessive

weight of metal was necessary. In the present construction, the parts of the supporting mechanism are made entirely of sheet metal, which can be bent or otherwise manipulated into form as by being struck up in dies and cut out and formed to the shapes desired. Sheet metal, being capable of bending and of being struck up, permits me in the manufacture of such device to form and shape the same with less weight of metal than in cases where such devices are made from cast metal. The practical result of the use of sheet metal in the manufacturing of such devices, as against devices for the same purpose made from cast metal pieces, is cheapness in the cost and lightness of parts, while yet the desired strength is retained.

What is claimed as new is—

1. In a trolley wire supporting mechanism

and in combination with insulating parts extending from the wire, supporting devices consisting of parts struck from sheet metal and formed so as to be adapted to conjointly engage the trolley wire supports, as and for the purpose set forth.

2. A trolley wire support, consisting of an insulating device attached to the wire, and two-part engaging devices clasping said insulating support and being struck up or formed from sheet metal and adapted to conjointly engage each other and the said insulating support, as and for the purpose set forth.

JOHN J. GREEN.

Witnesses:

ENOCH HAMMOND,  
E. A. SCRIBNER.