

April 29, 1941.

J. LIEBERMAN

2,240,077

SEAT CUSHION

Filed Nov. 9, 1938

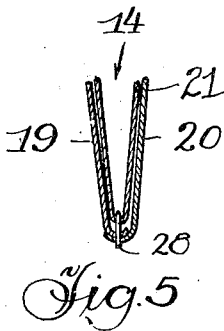
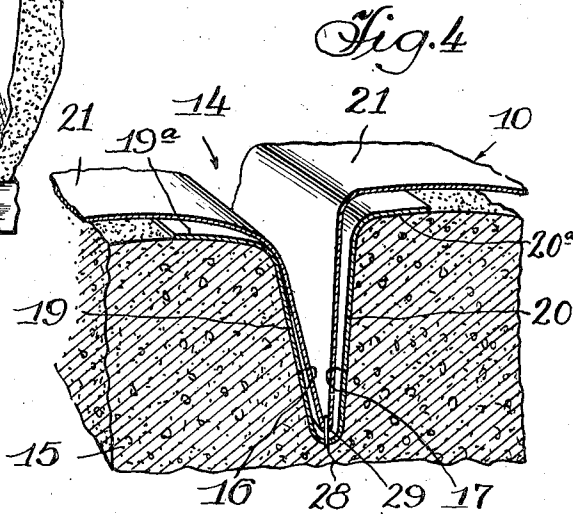
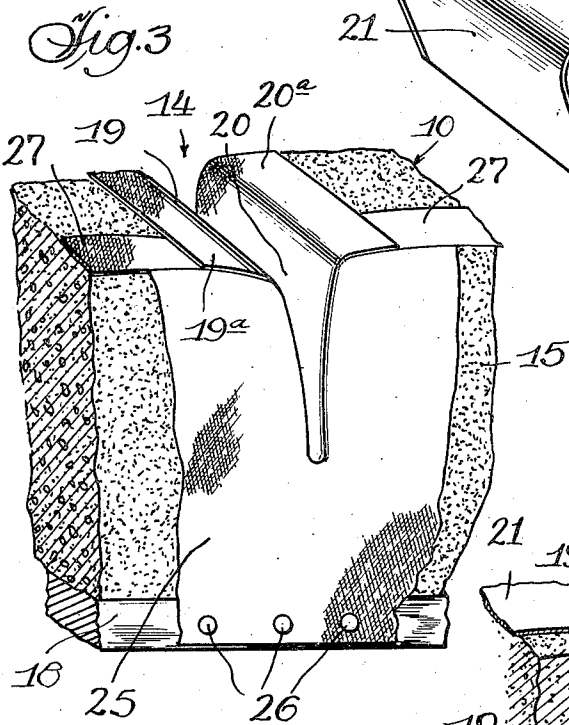
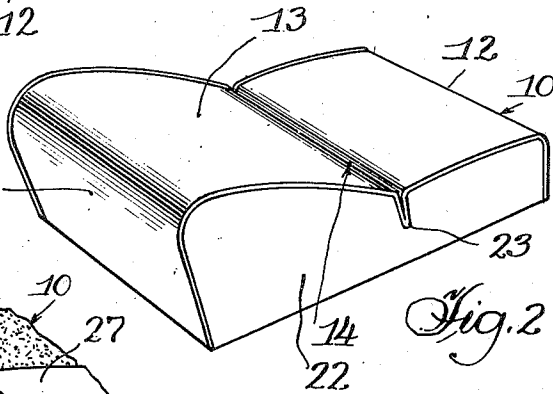
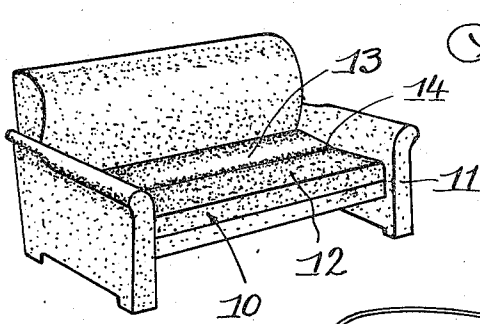

INVENTOR.  
Joseph Lieberman,  
BY  
Offield Nellhope Scott & Poole  
ATTORNEYS.

## UNITED STATES PATENT OFFICE

2,240,077

## SEAT CUSHION

Joseph Lieberman, Stevensville, Mich.

Application November 9, 1938, Serial No. 239,699

6 Claims. (Cl. 155—179)

This invention relates to improvements in seat cushions adapted for use in furniture of various kinds, and more particularly to cushions of the non-tufted type such as are made of sponge rubber having a flexible covering material such as fabric or leather fitted thereover.

One of the principal difficulties heretofore encountered in the production of non-tufted seat cushions of the general character described is that of applying the cover over the relatively wide and usually concaved surface of the cushion in such a manner that it can be maintained against wrinkling and excessive stretching during ordinary use, and which will mold itself to the body, together with the cushioning material when the seat is in use.

In carrying out my invention I provide the cushion body with an open slot preferably extending transversely of the seat cushion at an intermediate point along its upper surface and preferably at a point where a break or change in contour from the front to the rear of the cushion occurs. Within this slot I provide means for anchoring a fold of the cushion cover at the bottom of the slot throughout the entire width of the cushion. The effect of this arrangement is to keep the seat cover taut across the face of the cushion and maintain an unwrinkled appearance regardless of the amount of use to which the cushion is put. This arrangement also permits the modeling of the cushion face into two parts having their surfaces at varying angles with respect to each other so that the cover does not move when the cushion is depressed because the slot opens and closes as the body weight shifts. This saves wear and tear on the cover and also on the clothes of the sitter. The slot construction also makes the cushion more comfortable by allowing the body weight to depress the back portion of the cushion independently of the front portion, or vice versa, when the body moves. In other words, the slot allows the cushion and cover to adapt themselves readily to the body with the maximum of comfort in all positions of the sitter.

As a further advantage the slot construction also permits the use of less expensive covering materials such as split or machined leather, as it is possible to form the cover of two smaller pieces rather than a single large piece. It is also unnecessary that the covering material be especially resistant to wrinkling and stretching because with the improved arrangement the covering material is maintained in relatively taut and yet flexible fitting arrangement over the top surface of the cushion.

These and other objects and advantages of the invention will appear more fully as the following description proceeds.

The invention may best be understood by reference to the accompanying drawing, in which

Fig. 1 is a perspective view of a davenport in which the seat cushion is constructed in accordance with my invention.

Fig. 2 is an enlarged perspective view of a single seat cushion, somewhat shorter longitudinally than the cushion shown in Fig. 1, so as to be adapted for use in a chair or the like.

Fig. 3 is an enlarged detail perspective view of one side of the cushion body shown in Fig. 2, but with the cover removed adjacent the end of the slot to show the anchoring strips applied along the bottom and sides of said slot.

Fig. 4 is a section taken through the cushion body transversely of the slot, showing one means of attaching the cover to the anchoring strips along the base of the slot.

Fig. 5 is a view similar to Fig. 4, but showing a modified arrangement of the anchoring strips at the base of the slot.

Referring now to details of the invention illustrated in the drawing, Fig. 1 illustrates the use of my improved seat cushion 10 of the non-tufted type as applied to a relatively long davenport or similar piece of furniture 11.

Fig. 2 shows a finished cushion employing the same improved construction which is made as a unit to be employed in a single seat or chair, or which can be made in two or more units so as to fit in a longer davenport such as shown in Fig. 1. In both forms of cushions shown in Figs. 1 and 2 it will be observed that the upper surface thereof consists of a front portion 12 and a rear portion 13 divided by a relatively deep transverse slot indicated generally at 14 extending from one side to the other. The two surfaces 12 and 13 preferably are arranged at oblique angles to each other so that the slot 14 is disposed along the "break" of the seating surface of the cushion. The flexible body of the cushion may be made up of any suitable upholstering material, but in the preferred form shown the cushioning material comprises a sponge rubber body 15 which may be molded or otherwise formed in a single piece, but with an open slot formed by upright side walls 16 and 17 meeting at the base of the slot indicated generally at 14. In the form shown in detail in Figs. 2 and 3, the rubber body is mounted on a suitable rigid base such as said wood frame 18. This slot is of substantial depth, as for instance, extending approximately one-half of the vertical height of the cushion body 15.

Anchoring strips 19 and 20 of fabric or similar material having substantial thickness and strength are secured along the opposed side walls 16 and 17 of the slot for the full depth of the latter as shown in Figs. 3 and 4, so as to provide an anchoring means for the covering material indicated generally at 21. The anchoring strips 19 and 20 may be formed integral with each other as shown in Fig. 4, or may be made up of separate pieces stitched together adjacent the base

of the slot as shown in the modified form in Fig. 5. Where sponge rubber is used for the cushion body, the anchoring strips 19 and 20 are secured to the surface thereof by rubber cement of any suitable kind, so that said strips are permanently connected to the respective side walls 16 and 17 of the slot. The upper margins 19<sup>a</sup> and 20<sup>a</sup> of the strips are preferably extended a short distance over their respective upper edges of the slot as shown in Figs. 3 and 4.

The cushion body 15 may be secured to the base 18 in any suitable manner. In the form shown in Fig. 3 a fabric strip 25 is cemented along the side faces of the rubber block 15 and is secured along the adjacent edge of the frame 18 as by nails 26, 26. Fabric edging strips 27, 27 may also be cemented along the upper side edges of the cushion body 15, if desired, to reinforce the exposed upper corners of the cushion body.

With the anchoring strips 19 and 20 secured within the slot as shown in Fig. 4, the seat cover indicated generally at 21 is secured to the said anchoring strips as by forming a row of stitching 28 along the fold 29 of the cover, and through the meeting fold of said strips along the bottom of the slot, as shown in Fig. 4. The flexible rubber cushion body permits the slot to be spread open for this purpose.

In a modified form and arrangement of anchoring strips 19 and 20 shown in Fig. 5, the row of stitching 28 is passed through the overlapped meeting edges of said anchoring strips.

After the folded central portion of the cover 21 has been secured in the slot in this manner, the free ends of the cover may then be drawn tautly over the front and rear surfaces 12 and 13 of the cushion and secured along the front and rear of the cushion in any suitable manner. In the form of seat cushion shown in Fig. 2, the cushion cover 21 also has side panels 22 formed integrally therewith, and in this case the entire cover including the side panels 22 are pre-formed to fit over the cushion and with a slotted portion 23 provided in said side panel as shown. The cover is first applied to the body by anchoring the upper surface thereof in the cushion body slot 14, and thereafter the cover 21 and side panels 22 are secured to the base frame 18 along the front, rear and sides in any suitable manner, as by tacking.

Although best results are obtained by using molded sponge rubber for the cushioning body, it will be understood that other forms of flexible material can be substituted in whole or in part for sponge rubber, or that the use of rubber can be limited to an area of the cushion adjacent the slot 14.

With the construction above described, it will be observed that the strip to which the cover is anchored, is embedded in the cushion body so that said anchoring strip is yieldable with said body in all directions. Thus there is less strain on the anchoring means, and the danger of parting of the cover from its anchoring means during hard usage is reduced to a minimum. Moreover, with this arrangement the cover is maintained under yielding tension over the adjacent sitting surfaces of the cushion under varying degrees of compression of the entire cushion body and varying positions of the sitters thereon.

Although I have shown and described certain embodiments of my invention, it will be under-

stood that I do not wish to be limited to the exact construction shown and described, but that various changes and modifications may be made without departing from the spirit and scope of my invention as defined in the appended claims.

I claim as my invention:

1. In a seat cushion, a relatively thick cushioning body having a slot extending across the upper seating surface thereof, a flexible cover for said body having a fold fitting in said slot, anchoring means for said fold including a flexible strip secured and embedded within said body along said slot, said flexible strip being yieldable in all directions with adjacent portions of said body, and means securing said fold to said flexible strip at a plurality of points within and along said slot.

2. In a seat cushion, a relatively thick pliable cushioning body having a slot extending across the upper seating surface thereof, a strip of fabric or the like embedded and secured within and along said slot so as to be yieldable in all directions with adjacent portions of said body, and a flexible cover for said body having a fold fitting in said slot and secured to said strip.

3. In a seat cushion, a relatively thick cushioning body of sponge rubber or the like, having a slot extending across the upper seating surface thereof, a cover for said body consisting of a flexible sheet having a fold fitting in said slot, a strip of fabric or the like cemented to the inner walls of said slot, and stitching securing said fold along said strip to anchor the same yieldably within said slot.

4. In a seat cushion, a relatively thick cushioning body of sponge rubber or the like having a slot formed with upright, substantially parallel opposed walls of substantial depth and extending across the upper seating surface thereof, a cover for said body consisting of a flexible sheet having a fold fitting in said slot, a strip of fabric or the like cemented to the inner walls of said slot, and a line of stitching securing said fold along said strip to anchor the same yieldably within said slot.

5. In a seat cushion, a relatively thick cushioning body of sponge rubber or the like having a plurality of substantially flat upper seat sections arranged at oblique angles to each other, and provided with a slot extending across the upper seating surface thereof along the meeting line of said seat sections, a cover for said body consisting of a flexible sheet having a fold fitting in said slot, a strip of fabric or the like cemented to the inner walls of said slot, and stitching securing said fold along said strip to anchor the same yieldably within said slot.

6. In a seat cushion, a relatively thick cushioning body having an upper seating surface formed of a plurality of substantially flat portions arranged at oblique angles to each other, and provided with a slot extending across said seating surface at the meeting line of said portions, an anchoring strip of fabric or the like embedded and secured within and along said slot so as to be yieldable in all directions with adjacent parts of said body portions, and a flexible cover for said body having a fold fitting into said slot and secured to said strip at a plurality of points therealong.

JOSEPH LIEBERMAN.