

No. 686,714.

Patented Nov. 19, 1901.

J. W. CLAYTON.

QUILTING FRAME FOR SEWING MACHINES.

(Application filed Oct. 16, 1900.)

(No Model.)

2 Sheets—Sheet 1.

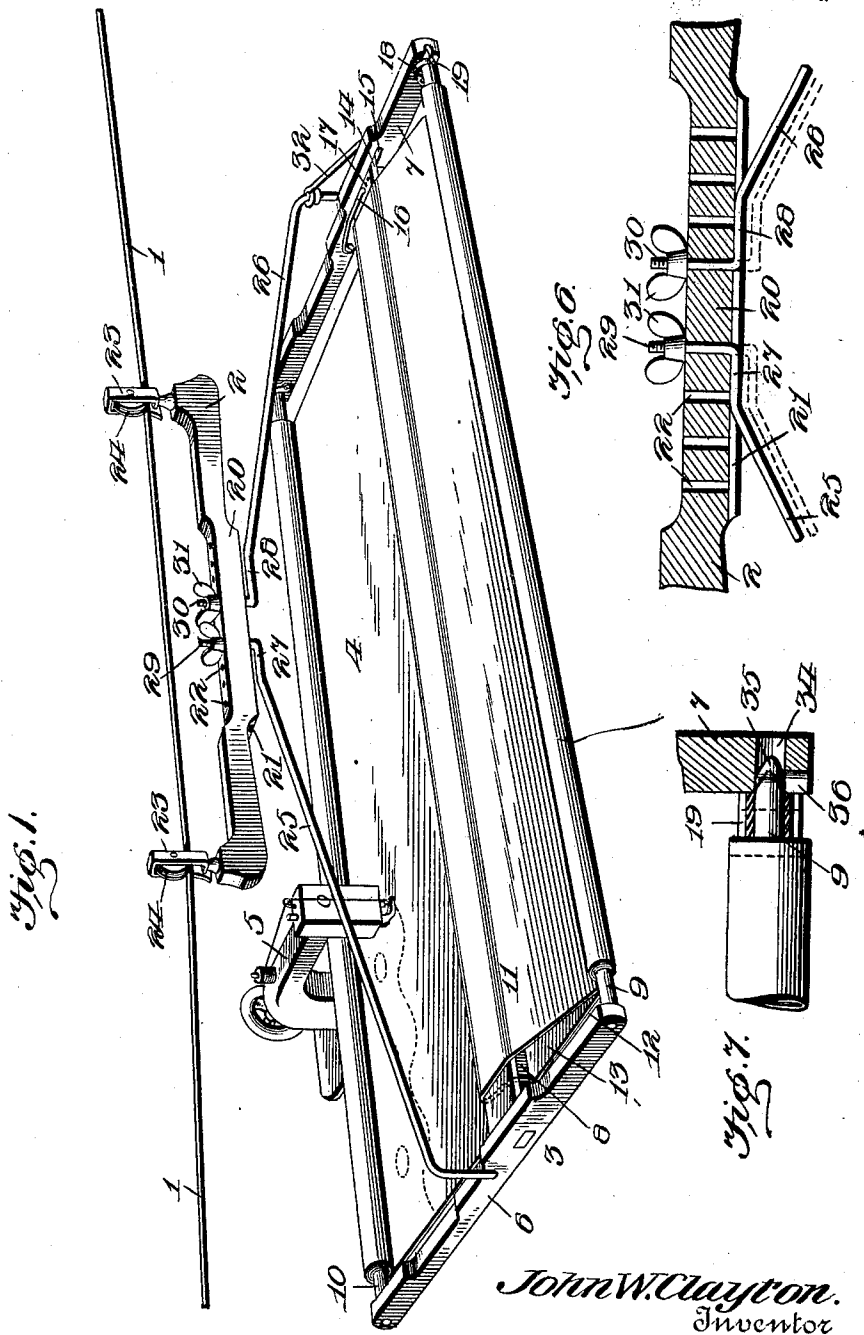

John W. Clayton.  
Inventor

Witnesses  
Geo. P. Payne  
Louis J. Dulihn

By  
E. G. Siggers  
Attorney.

J. W. CLAYTON.  
QUILTING FRAME FOR SEWING MACHINES.

(Application filed Oct. 16, 1900.)

(No Model.)

2 Sheets—Sheet 2.

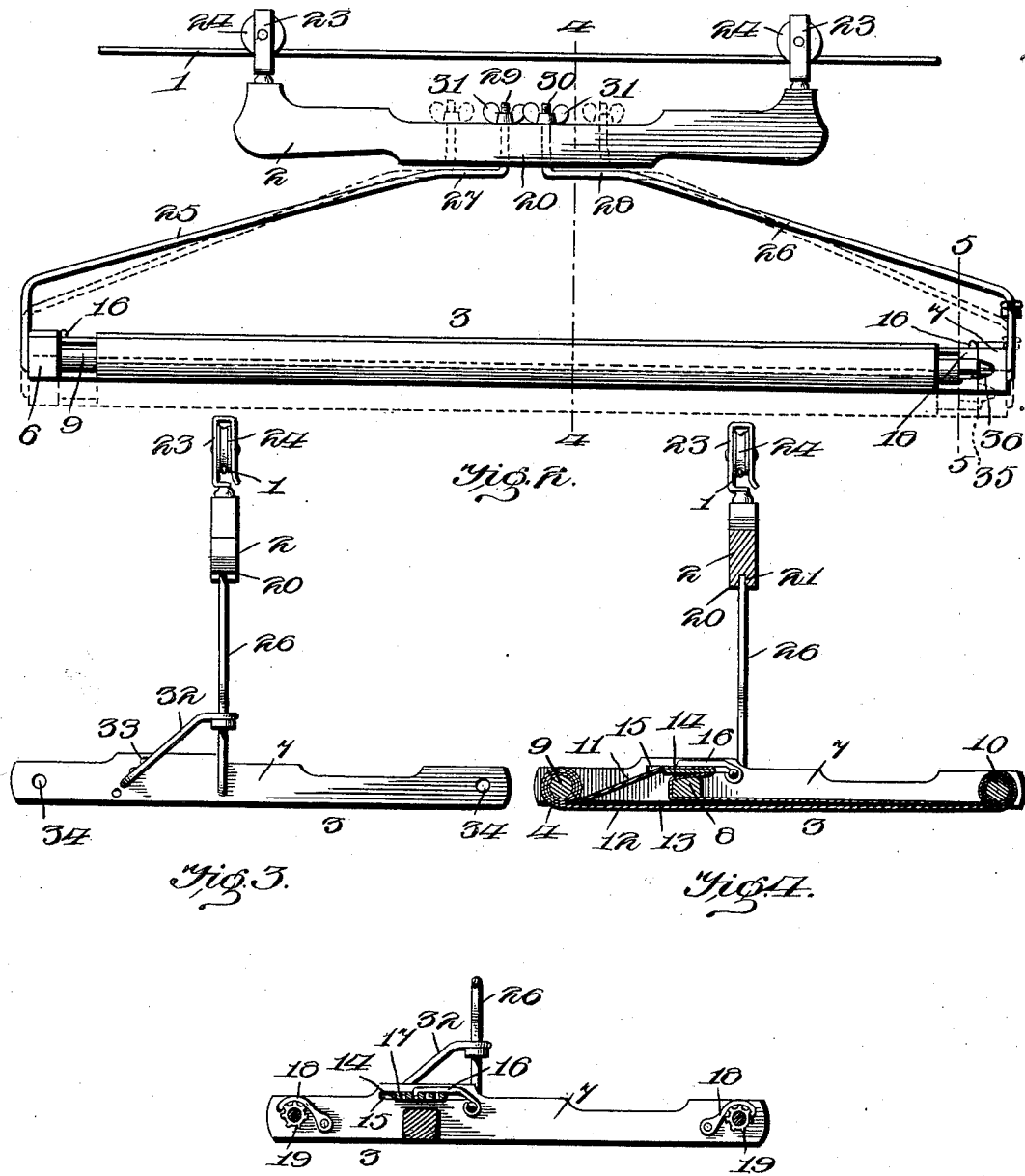

Fig. 3.

Fig. 4.

Fig. 5.

John W. Clayton  
Inventor

Witnesses  
Geo. F. Burne  
Louis Julihn

By  
E. J. Siggart  
Attorney

# UNITED STATES PATENT OFFICE.

JOHN WILLIAM CLAYTON, OF ATLANTA, GEORGIA.

## QUILTING-FRAME FOR SEWING-MACHINES.

SPECIFICATION forming part of Letters Patent No. 686,714, dated November 19, 1901.

Application filed October 16, 1900. Serial No. 33,280. (No model.)

*To all whom it may concern:*

Be it known that I, JOHN WILLIAM CLAYTON, a citizen of the United States, residing at Atlanta, in the county of Fulton and State of Georgia, have invented a new and useful Quilting-Frame for Sewing-Machines, of which the following is a specification.

My present invention relates to improvements in quilting attachments of that type which are employed in connection with sewing-machines and which embody a traveler or carrier movably supporting the quilting-frame to present the quilt, supported by the frame, under the needle of the machine. In this class of devices the quilting-frame includes a pair of rollers at opposite sides thereof for the reception of the quilt, which is wound from one roller to the other as the quilting is effected by the machine. It therefore follows that the space between the rollers will be occupied by the unquilted upper and lower fabrics and the intermediate batting. These three layers extend between the lower edges or under sides of the rollers, and it is well understood by those skilled in the art that the upper or top layer of fabric will as the rollers are operated loosen up to an extent which interferes more or less with the operation of the machine.

The primary object of my invention, therefore, is to provide a novel device for taking up the slack in order that the upper fabric layer of the quilt will be drawn taut to present a smooth even surface in close contact with the padding to facilitate the quilting operation.

A further object of the invention is to provide an improved construction of carriage accommodating lateral adjustment of the upper ends of the frame-supporting arms to effect the elevation or depression of the frame and the longitudinal movement of said ends for the purpose of securing the rigid retention of the latter when it is desired to sew in straight lines across the quilt or the less rigid retention thereof when it is desired to permit more or less twisting movement of the quilting-frame for the purpose of sewing in irregular lines or figures.

A still further object of the invention is to provide adjustable means for maintaining the proper relative position of the quilting-

frame with respect to the supporting-arms, and a still further object is to provide simple connection or mounting of the rollers to facilitate their attachment to or withdrawal from the frame.

To the accomplishment of these objects the preferred embodiment of the invention comprehends the construction and arrangement to be hereinafter described, illustrated in the accompanying drawings, and defined in the appended claims.

In said drawings, Figure 1 is a perspective view of my device applied as in use. Fig. 2 is a front elevation thereof, showing the frame depressed in dotted lines. Fig. 3 is an end view of the subject-matter of Fig. 2. Fig. 4 is a sectional view on the line 4 4 of Fig. 2. Fig. 5 is a sectional view on the line 5 5 of Fig. 2. Fig. 6 is a detail sectional view illustrating the adjustable connection of the supporting-arms with its carriage, and Fig. 7 is a detail view of the roller-mounting.

Referring to the numerals employed to designate corresponding parts in the several views, 1 indicates a supporting track or wire supported at its ends in any suitable manner and having a slight longitudinal inclination to facilitate the movement of a carriage 2, suspended therefrom and supporting the quilting-frame 3 in position to present the quilt 4, carried by the frame, to a sewing-machine 5, employed for the quilting. The frame 3 comprises the end bars 6 and 7, connected by the main frame-bar 8, disposed in a plane intermediate of the ends of said bars to retain them in position for the reception of the quilt delivering and receiving rollers 9 and 10, journaled between the end bars at the outer ends thereof.

The material from which the quilt is formed and comprising upper and lower layers 11 and 12 of fabric and an intermediate layer of cotton-batting or other stuffing 13 is wound upon the delivering-roller 9 and passes from the under side thereof under the frame-bar 8 to the under side of the receiving-roller 10, upon which latter it is wound from the roller 9 as the operation of quilting progresses. This movement of the quilt effects the feed thereof in one direction with respect to the sewing mechanism, and the bodily endwise movement of the frame as the carriage moves

along the track effects the feed in a direction at right angles to the movement of the quilt upon the frame—that is to say, the shifting of the frame by the movement of the carriage causes the quilt to be advanced under the needle to produce the line of sewing or quilting and the winding of the material across the frame takes up that portion which has been quilted and presents an expanse of unquilted fabric for the further operation of the sewing-machine. I have found in practice, however, that the upper layer of fabric 11 intermediate of the rollers will be subjected to somewhat less tension than the under fabric or lining, and as this is an undesirable feature by reason of its impediment of the quilting operation and because of the appearance of the quilt when finished I have provided a simple and effective tension device which will permit the upper layer of fabric to be drawn perfectly taut at the point of sewing and quilting. This tension device comprises a flat tension bar or slat 14, having its opposite ends extended into elongated slots or recesses 15 in the opposed faces of the end bars, preferably directly above the main frame-bar 8. The recesses 15 are of greater length than the width of the bar 14 to permit the latter to be shifted laterally for the purpose of regulating the tension of the fabric layer 11, which is passed from the delivery-roller 9 over and around the tension-bar 14 and around and under the main frame-bar 8 in the reverse direction, so that as the tension-bar is moved rearwardly or toward the receiving-roller the loop of the fabric will be extended and that portion lying between the frame-bar 8 and the receiving-roller will be drawn as tight as may be desired. For the purpose of retaining the tension bar or slat in its adjusted positions I provide retaining-hooks 16, pivoted to the end bars and arranged for engagement with any one of a series of openings or recesses 17, extending transversely across the slat at each end thereof. The movement of the rollers is controlled, as usual, by pawls 18, pivoted upon the end bars and engaging small ratchet-wheels 19, carried by the rollers.

I have stated that one important feature of my invention is the peculiar construction of the carriage, whereby the quilting-frame is compelled to move in a direct line as the carriage advances or is permitted to have a slight lateral movement, accordingly as it is desired to quilt in a straight line or otherwise. To this end I construct a carriage in the form of an elongated bar having a depressed central portion 20, provided with a longitudinal recess 21 in its under face and with a series of vertical openings 22 in alinement with the recess, the carriage thus formed being supported by upstanding roller-brackets 23, carrying rollers or travelers 24, movable upon the wire or track 1. The quilting-frame is supported from the carriage by means of a pair of downwardly-divergent supporting-arms 25 and 26, constituting a sort of bail and

having angular lower ends, upon which the end bars 6 are pivotally supported medially. Adjacent to their upper ends the supporting-arms are bent to form horizontal offsets 27 and 28, which terminate in vertically-disposed screw-threaded shanks 29 and 30, passed upwardly through the openings 22 and provided on their upper ends with wing-nuts 31, by means of which the shanks are drawn longitudinally for the purpose of locating the offsets 27 and 28 within the recess 21 of the carriage when it is designed to prevent twisting movement thereof or to locate said offsets below the recess when it is desired to quilt in irregular lines—that is to say, when the shanks of the supporting-arms are drawn up to their full extent the offsets 27 and 28 will be located within the recess 21, between the walls of which they will be clamped in a manner to insure the retention of the arms in alinement with the carriage, the result of which will be to compel the quilting-frame to move bodily in a straight line as the carriage advances. If, on the other hand, the shanks are dropped to permit the offsets to move out of the recess 21, the arms will be permitted to swing laterally to a given extent in opposite directions for the purpose of causing the sewing mechanism to describe various patterns upon the quilt. If at any time it is desired to elevate or depress the frame slightly—as, for instance, in securing the accurate positioning of the fabric with respect to the sewing mechanism—the shanks of the supporting-arms may be withdrawn from the openings 22 occupied by them and moved to others more or less separated, as shown in Fig. 2 of the drawings.

Another important feature of the present invention resides in the employment of a simple device for preventing tilting of the frame under the weight of a preponderance of material upon either of the rollers and for permitting the frame to be retained in several angular positions, if desired. This means comprehends the employment of a frame-retaining hook 32, carried by one of the supporting-arms and designed to engage any one of a series of recesses 33 in the contiguous side bar of the frame. It will be noted that when the hook 32 is in engagement with either recess it will constitute a connecting element with the arm and end bar at points removed from the pivotal connection of those members, the result being the rigid retention of the quilting-frame with respect to pivotal movement, no matter how much material may be wound upon either of the rollers or at what inclination the frame may have been set.

The remaining feature of the invention relates to the manner of mounting the rollers in the end bars of the frame to facilitate their removal when necessary. To this end the extremities of the rollers are reduced in diameter and are passed into openings 34 in the bars 6 and 7, my improvement consisting in forming one of the reduced ends of each

roller with a conical extremity 35, which upon springing the end bar slightly may be withdrawn laterally from the opening 34 through a correspondingly-shaped recess 36 formed in the inside face of the end bar and extending from the extremity thereof to the opening 34, as clearly illustrated in Fig. 1 of the drawings. It will be noted that by this provision the rollers are given an extended bearing in the end bar and are at the same time readily releasable by such slight springing of the bar as will not tend to endanger the connection between the parts of the frame.

From the foregoing it will be observed that I have produced a simple and efficient quilting attachment of the character described embracing a novel construction best calculated to effect the accomplishment of the several objects noted; but while the present embodiment of my invention is believed at this time to be preferable, I do not desire to limit myself to the structural details defined, as it is evident that many changes, modifications, and variations thereof might be effected without departing from the spirit of the invention.

What I claim is—

1. In a quilting attachment of the character described, the combination with a frame, of delivery and receiving rollers, a frame-bar intermediate of said rollers and a tension-bar extending parallel with the rollers above said bar and capable of lateral adjustment, and means for retaining said bar in its adjusted positions.

2. In a quilting attachment of the character described, the combination with a frame comprising a main bar and end bars provided with recesses in their opposed faces, of delivery and receiving rollers mounted between the end bars at opposite sides of the main bar, a tension-bar located within the recesses and arranged for movement toward or from the rollers, said tension-bar being provided with a series of recesses, and a retaining-hook carried by the adjacent end bar and designed to engage said recesses to hold the tension-bar in its adjusted positions.

3. In a quilting attachment of the character described, the combination with a carriage and quilting-frame, of supporting-arms provided with offsets, and adjustable means for connecting the arms to the carriage and for drawing the offsets of the former into engagement with said carriage.

4. In a quilting attachment of the character described, the combination with a recessed carriage and a quilting-frame, of a pair of frame-supporting arms provided with shanks

disposed at an angle with respect to the arms, and means for adjusting said shanks with respect to the carriage to effect the engagement of the supporting-arms with the recess thereof.

5. In a quilting attachment of the character described, the combination with a carriage provided with a recess in its under face and with a series of vertical openings, of a quilting-frame, a pair of frame-supporting arms provided with offsets and having terminal shanks passed through the openings in the carriage, and means for drawing up the shanks to bring the offsets of the arms within the recess.

6. The combination with a carriage, quilting-frame and frame-support, of cooperating retaining devices carried by the support and carriage adapted to be drawn into interfitting relation, and means for vertically lifting the support toward the carriage to effect the temporary engagement of said retaining devices.

7. In a quilting attachment of the character described, the combination with a carriage provided with a series of openings, of a quilting-frame, a pair of frame-supporting arms provided with shanks passed through certain of said openings in the carriage, and nuts screwed upon the upper ends of the shanks.

8. In a quilting attachment of the character described, the combination with a movable carriage, of a quilting-frame supported by the carriage, connecting means intermediate of the carriage and frame, said means being adjustable to different positions to effect the rigid connection of the carriage and frame and to permit the movement of the frame about a vertical axis, and means for limiting such movement of the frame to a partial rotation, whereby the frame when not rigidly connected to the carriage may be oscillated to facilitate the stitching of curved or irregular lines.

9. In a quilting attachment of the character described, the combination with the carriage and frame, of supporting-arms for said frame, separate securing devices connecting said arms individually and independently to the carriage, and means operated by said securing devices for retaining the said arms against lateral movement with respect to the carriage.

In testimony that I claim the foregoing as my own I have hereto affixed my signature in the presence of two witnesses.

JOHN WILLIAM CLAYTON.

Witnesses:

H. H. FOX,

J. E. JOHNS.