

Aug. 19, 1930.

A. FLETTNER

1,773,453

VENTILATING DEVICE

Filed March 22, 1928

2 Sheets-Sheet 1

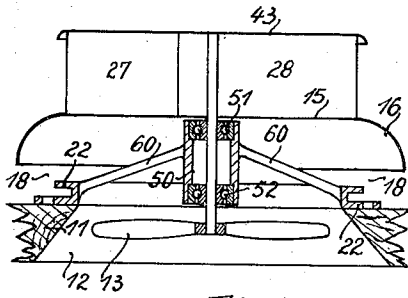

Fig. 1

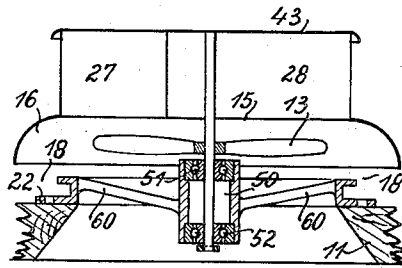

Fig. 2

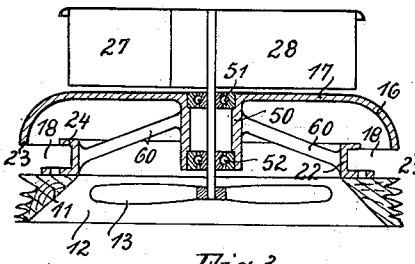

Fig. 3

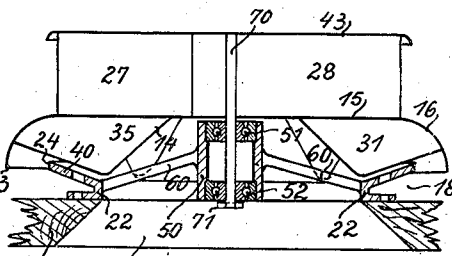

Fig. 4

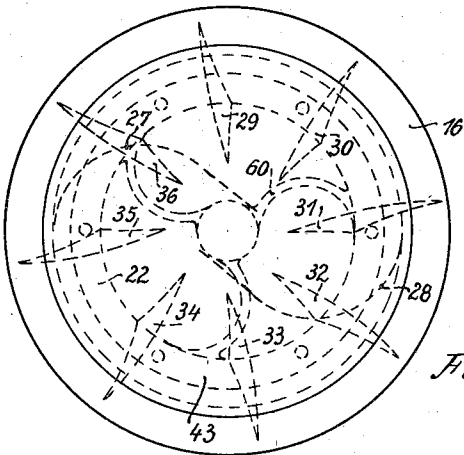

Fig. 5

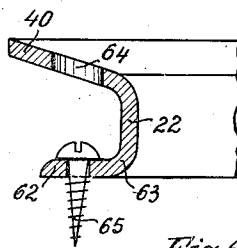

Fig. 6

Inventor

Anton Flettner

by

Knight Bros

Attorneys

Aug. 19, 1930.

A. FLETTNER

1,773,453

VENTILATING DEVICE

Filed March 22, 1928

2 Sheets-Sheet 2

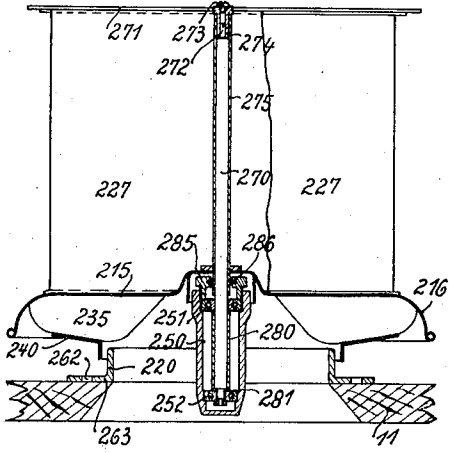

Fig. 7

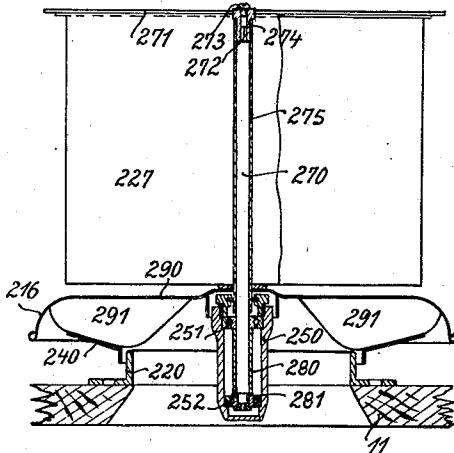

Fig. 9

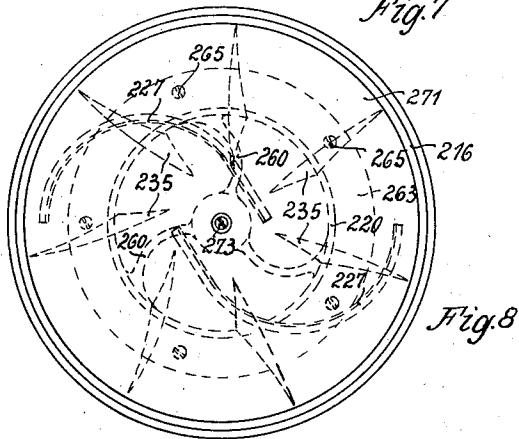

Fig. 8

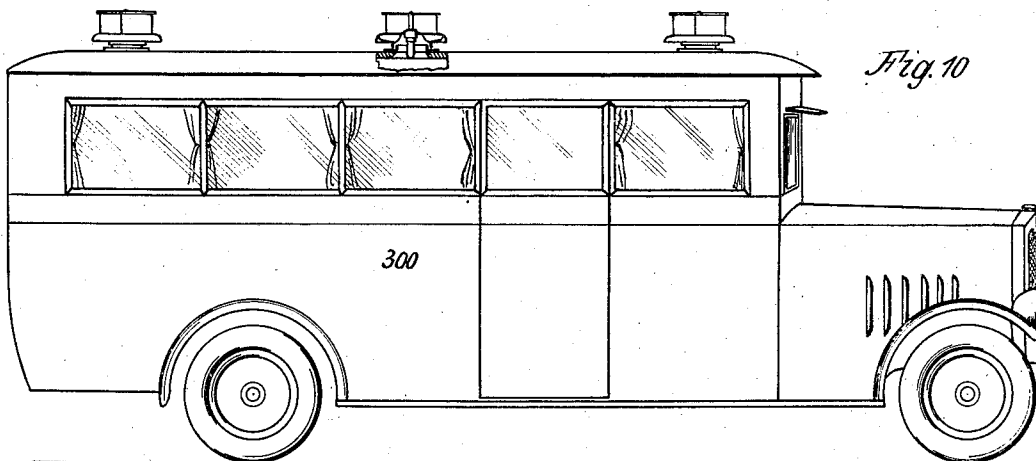

Fig. 10

Inventor
Anton Flettner
by Knight Bros. Attorneys

UNITED STATES PATENT OFFICE

ANTON FLETTNER, OF BERLIN, GERMANY

VENTILATING DEVICE

Application filed March 22, 1928, Serial No. 263,872, and in Germany April 2, 1927.

My invention relates to improvements in ventilating devices for rooms, more particularly for cars, in which the rotor driving the fan for instance for exhausting the room is driven by a current of air passing along the room or edifice or building or construction to be ventilated or the car or which current, conversely, is produced if the room or the like or the car moves in a medium such as air.

A preferred embodiment of my invention relates to ventilating devices for rooms or cars in which the current of air from or to the interior of the room or the like or the car conducted through the wall or the roof or in opposite direction by means of rotating conveyors is ejected aside, or drawn in from the sides above the outlet of the wall or roof. More particularly the object of my invention is, on the one hand, the covering up of the outlet in such a manner that the ventilation process may take place undisturbed under favorable aerodynamic conditions, while on the other hand the outer flow passing the edifice, building, construction or the like, or the flow of air set up by the speed of the car, tram, railway, bus, auto aircraft, vessel or the like, as well as foreign bodies or particles, such as dust, soot, rain and the like are prevented from entering the ventilation opening in the wall or the roof of the room or the like or the car or vehicle.

My invention consists, furthermore, of a particular favorable constructive development of the bearings of the fan as well as the driving rotor operating the fan.

In order to protect the ventilation opening as well as the fan which may be located in or adjacent to it or parts of the fan against the detrimental action of the outer wind and to prevent at the same time the entrance of rain, dust, or any other foreign bodies or particles into the interior of the room or the like to be ventilated or the car, I cover the passage opening in ventilating devices for rooms, cars, or the like in which the current of air conducted from the interior of the room through the wall or the roof or in opposite direction by means of revolving conveyors, is ejected sideways or drawn in from

the sides above the passage opening, by means of a disc provided with a bore through which the shaft penetrates, the shaft being driven by the driving rotor and in its turn driving the fan.

My invention relates furthermore to the advantageous development of this disc, as well as to novel fan and rotor constructions, as well as to suitable bearings for these and to the favorable guidance of the current of air to be set up and serving for the ventilation of the room or the like.

Further improvements of my invention relate to the arrangements and construction of discs which cover the free towering edges of the fan blades, and to arrangements and constructions of boxes which house the bearings of the shaft common to the ventilating device, and finally to a novel attachment of fan and rotor upon the shaft.

In the drawings affixed hereto and forming part of my specification a number of embodiments of my invention are diagrammatically illustrated, by way of example.

The drawings present in Fig. 1, a sectional elevation of my improved ventilating device,

Fig. 2, another modification of the device in sectional elevation,

Fig. 3, a similar view of a further modification,

Fig. 4, a sectional elevation of a still further modification,

Fig. 5, a plan view of the modification shown in Fig. 4,

Fig. 6, the carrier ring, shown in Fig. 4 in cross-section, on a larger scale,

Fig. 7, a still further modification in sectional elevation,

Fig. 8, a plan of Fig. 7,

Fig. 9, a modification of the arrangement shown in Fig. 7, and in

Fig. 10, the arrangement of the ventilating device shown in Figs. 7 and 8 on the roof of a vehicle.

Referring to Figs. 1 to 4 of the drawings, the wall of the room or the roof of the car is indicated by the reference numeral 11 and the passage opening serving for the ventilation by the numeral 12. The current of air

55

60

65

70

76

80

85

90

95

100

5 serving for the ventilation, which in the constructions shown in Figs. 1 to 3, is set in motion by a propeller type fan 13, and in the construction shown in Fig. 4 by a centrifugal action, and blows off above the roof towards the sides, for instance all round. The passage opening may, however, be covered or closed at certain points. According to my invention the passage opening 12 is covered by means of a disc 15, in Figs. 1, 2, 4, or by the shield 17 in Fig. 3. The covering element may either revolve with the wind motor, as in Figs. 1, 2 and 4, or be stationary, as 17 in Fig. 3.

15 In one of the preferred designs of my invention the disc is formed or shaped with a down turned rim, thus constituting a dome or bell shaped housing; the rim 16 of this disc is of sufficiently large diameter, so that an annular gap 18 remains between the housing rim and the face of the roof or wall, and so that to the current of air passing through the gap a component is imparted which is directed downwards along the edge of the bell shaped housing when ejecting air, or a component directed upwards along the rim of the bell when drawing in air.

20 For the further guidance of the current of air as well as a safeguard against disturbances from outside the structure is further improved by placing opposite the rim of the bell and inside of it a concentric ring, for instance as shown at 22 so that the edge 23 of the bell and the edge 24 of the ring are located at a distance from each other and may overlap one another when viewed from the side, as particularly clearly shown in Figs. 3 and 4. The amount of overlap may be very small.

30 The fan adapted to set up the current of air may be located in the ventilation opening 12 of the wall or roof, as shown in Figs. 1 and 3. A substantially more compact construction may, however, be obtained by locating the fan, for instance designed as propeller 13, Fig. 2, or a centrifugal ventilator 14, Fig. 4, in the cavity of the bell. The bell is then preferably so constructed, that its rim extends beyond the plane in which the lowest portion of the blades rotates.

35 The small height of the ventilator attainable by this construction which is particularly desirable for vehicles, such as railway cars, motorcars, tramway cars, busses, in which a certain gauge height must not be exceeded, may be still further reduced, if the fan and the driving rotor, operated by the current of air due to the speed of the car, are placed close to both sides of the bottom of the bell. In case of a stationary bell shaped housing this may be attained by locating the driving rotor closely adjacent to the bell, as illustrated in Fig. 3, in which case the fan may be housed within the space represented by the thickness of the roof structure.

If a centrifugal fan is employed a very shallow construction may be attained by mounting the vanes of the fan, so that they project downward from a carrier disc. The disc carrying the fan vanes may then be located closely adjacent to the roof inside of the bell shaped housing.

70 A further reduction of the height of the ventilator may be brought about, preferably if the dome or bell itself rotates with the rotor, by carrying on its outer face the vanes of the driving rotor (Fig. 1) or if the revolving bell (290 in Fig. 9) carries on the inner face the vanes 291 of the centrifugal fan, or if the revolving bell carries on its outer face the vanes of the driving rotor and at the same time on its inner face the vanes of the centrifugal fan.

75 These particular features are shown in the modification of my invention illustrated in cross-section in Fig. 4 and in plan view in Fig. 5. The bell carries on its outer face the vanes 27, 28 shown in broken lines in Fig. 5, of a rotor, for instance of that type in which the generatrices of the vane surfaces are substantially parallel to the shaft. I prefer the type of rotor in which are provided two diametrically oppositely arranged hollow vanes, each having a generally rectilinear generatrix, the inner edge of each vane extending to the segmental space bordered by the other vane, both vanes forming an air passage adapted to force the air current from the hollow side of one of said vanes to the hollow side of the other vane in an S-like path of substantially constant area. The inner side of the bell carries the vanes 29-36 of the centrifugal fan, these vanes projecting from the inner bell surface as shown in Fig. 4. In all cases, whether the bell rotates or is stationary, the bell rim is spaced from the car roof to leave sufficient space for the air to pass, but this rim extends at the same time slightly beyond the fan blades to cover them, and in particular to cover the vanes of the centrifugal ventilator at their radial outside edges, as shown for the revolving bell in Fig. 4.

80 From this results a perfectly protected arrangement also of the vanes of the centrifugal fan and a steady guidance of the air current, which permits of the reduction in ventilator height to an extraordinary extent, so that apart from the constructive advantages the external appearance of the device upon the car roof is considerably improved. The turned down rim of the bell acts furthermore in the manner of an exhaustor upon the air current ejected by the vanes of the centrifugal fan and thus increases the action of the ordinary fan or relieves the centrifugal fan.

85 The concentric or coaxial ring 22 which carries the hub 50 for the rotor bearing, is stationary and mounted at the mouth of the opening 12 in the roof 11. It thus properly

70

75

80

85

90

95

100

105

110

115

120

125

130

defines a central passage opening through the roof and is in a further development of the invention, in particular when the fan is designed as centrifugal fan, arranged in such a manner, that it follows with a flare 40 the lower outwardly extending edges of the vanes. This flare 40 should be located near the blade edges as close as possible, so that the narrowest possible gap only remains. This air gap is determined in size according to the size of the centrifugal fan and the other constructive conditions. It is preferably made as small as possible consistent with safe and reliable operation, and generally of the order of 2-5 mm.

The taper or gradient of this flare rim 40 is preferably so chosen, that it is, on the one hand, possible to accommodate a sufficiently large area of the centrifugal fan and that, on the other hand, an annular gap of such size results between the surface of the roof or wall or the like and the lower edge of the bell, that the issuing air may escape towards all sides without any restriction.

The course of the ventilating current or the passage area of the fan, the annular opening, the areas of the vanes, and the outlet gap are preferably so chosen, that from the inner parts to the outer parts the passage areas of the ventilator gradually and steadily increase between the bell covering it and the ring, so that the air current is not accelerated, but rather retarded and a favorable efficiency of the centrifugal fan is obtained in this way.

In the modification of my improved device illustrated in cross-section in Fig. 7 and in plan in Fig. 8 the driving rotor with its vanes 227 is mounted directly upon the outer surface of the bell 215, which on its inner face carries the substantially radial fan blades 235. The current of air sucked up from the interior of the car, for instance, first traverses the face ring 220 fastened on the roof and framing the ventilation opening and then flows, due to a small outwardly directed component, outward and upward through the fan, to be deflected outwards and downwards by the edge of the bell 216 covering the outer edges of the fan blades 235.

According to another feature of my invention the lower blade edges, which in the modification Fig. 4 are unsupported and project freely individually into the hollow bell space, carry in Fig. 7 an annular disc 240 to which they are attached at their lower edges. This annular disc is dished and faces the bell cavity with its hollow portion. By means of this improved arrangement the construction is considerably simplified and the assembly work substantially lessened. By mounting this annular disc 240 directly upon the blades, the blades are strengthened or stiffened to a large extent, so that their thickness may be reduced and no particular attention need be paid, as in the modification Fig. 4 to the uni-

form dimensions of a gap, which is necessary if as in Fig. 4, the tapering annular flare 40 is spaced from the edges of the blades.

All the parts to be assembled, in particular the frame ring 220 carrying both the rotor and the fan, may now be designed concentrically as a natural result of the arrangement according to my invention. Adjacent to the inner edge of the annular disc 240 is located the cylindrical upward extension of the frame ring 220, which may enter into the central portion of disc 240 or envelop this edge or it may terminate in its vicinity, of course with the required clearance for free rotation of the fan.

The driving rotor located above the bell shaped housing may be provided with a special stationary roof, but it may also be covered up by a roof plate 43, Fig. 4, or 271, Fig. 7 which revolves with the rotor.

In this and other ventilating devices for rooms, buildings and the like or vehicles of any kind in which the current of air is conducted from the interior of the room, car and the like, through the wall or roof, or passes in opposite direction, and where a common shaft carries the driving rotor as well as the fan, a constructively very advantageous arrangement results according to my invention, if the bearings of the driving rotor as well as the fan are located in a common housing carried by a support mounted on the wall or roof of the space to be ventilated.

As the modifications illustrated in the drawings show the common housing 50 Figs. 1-4, or 250 Figs. 7 and 9 for the bearings is preferably cylindrical or substantially cylindrical and carries at its ends two bearings 51, 52, in Figs. 1 to 4, respectively 251, 252, in Figs. 7 and 9, which are preferably ball-bearings or roller bearings. This housing may be located either between the driving rotor 27, 28 and the fan 13, as illustrated in Figs. 1 and 3, or as Figs. 2-4 and Figs. 7 and 9 show, below both of them. This common housing 50 for the bearing is shaped like a hub, centrally attached to the frame ring 22, previously mentioned, the arms 60 being provided for supporting this hub by the frame ring. In the modifications Figs. 1, 2, 4, 7 and 9 the hub extends into the cavity of the rotating bell, whereas in Fig. 3 the hub is integral with the stationary bell.

In this arrangement of a common housing for the bearings which is combined into a unit with the general annular supporting structure by which the whole device is attached to the object to be ventilated, and which structure may have integrally combined with it the guide flanges in case of a centrifugal fan, or which in case of a stationary bell, may have the bell integrally combined with it, the entire ventilating device is, according to my invention, reduced to only two main elements to be assembled for instal-

lation, namely on one hand the stationary supporting frame structure which includes the bearing hub and the guide apron in case of a centrifugal fan, and on the other hand the revolving unit, which in a simple construction for instance according to Fig. 4 may consist of a disc preferably bell shaped which on one side carries the vanes of the driving rotor and on the other side the centrifugal vanes. This construction reduces the cost of manufacture considerably, particularly in case of mass production and results in an easily accessible and cheap construction and enables the ventilating device to be mounted on the wall or the roof of the room, car and the like by means of a single flange (as in Figs. 4 or 7 and 9) and simple fastening means, such as screws, so that the wall or the car roof need not undergo an expensive structural change, but the ventilation opening need only be cut out of it.

This arrangement results furthermore in an extraordinary compact construction of small height, if the journal bearing is accommodated in the cavity of the bell. This is in the preferred construction of my invention effected by the termination of the centrifugal vanes in the interior of the bell, as shown in Fig. 4, at such a distance from the centre, that they leave ample space for the accommodation for the housing of the bearings.

In the modification of my invention illustrated in Figs. 7 and 8 of the drawings the housing 250 for the reception of the bearings is designed as oil box by being provided with a closed bottom, which may be provided with an oil drain screw (not shown). The two ball bearings 251, 252 are located at the upper and lower end of the box respectively, and are provided with the necessary ball races, the external diameter of the upper bearing 251 being chosen greater than that of the lower bearing, to facilitate the withdrawal of the lower bearing.

The inner races may in the customary manner be keyed to or loosely mounted upon the common shaft 270 of the device. In order to maintain the spacing of the bearings, when withdrawing the shafts together with the bearings, a sleeve 280 is provided which is slipped over the shaft 270 and the length of which is such, that after the shaft with its bearings has been introduced into the journal housing the sleeve ends a little below the seat of the outer ring of the bearing 251 in the housing, so that the cap nut 285 to be screwed into the housing and which presses the bearing against the seat does not bind the bearing against the sleeve. This cap nut in cooperation with the spacing sleeve 280 thus ensures the proper fit of the bearing within the housing. A washer 281 preferably serves as lower abutment for the spacing sleeve 280 and is able to absorb the axial thrust of the upwards

directed forces originating from the lower bearing.

The housing may be filled with oil up to the level of the upper ball-bearing or even beyond it, and special means of replenishing the oil may be provided in the customary manner. Above the cap nut the shaft can freely penetrate through the disc or the base of the bell and the rotor. In order to protect the shaft against atmospheric influences it may be enclosed by a protective tube 275 upon which, for instance, the two end discs of the rotor, the base of the bell 215 and the top disc 271 may be mounted.

The housing of the bearing is joined to the main supporting ring by a suitable number of arms 60, Figs. 4 and 5 or 260, Figs. 7 and 8, which mainly for manufacturing reasons and to prevent stresses in the casting may be curved and which are preferably of stream line cross-section and which have a pitch in the direction of the current of air in order to impart to the current of air an admission twist adapted to the pitch of the fan blades.

In order to keep in the arrangement according to Figs. 4 and 5 the weight and the dimensions of the attachment frame 22 small, the flaring guide flange 40 may be provided with suitable perforations 64 as shown in Fig. 6 on an enlarged scale through which the fastening means, for instance, screws 65 and the tools for fastening them such as the screw drivers may be introduced. In this way the diameter of the attachment flange 62, and thus the weight of the main supporting ring may be made small.

The mounting of the ventilating device upon the roof of the car is extremely simple. To start with, for instance in Fig. 4 the casting consisting of the annular frame 22 and the journal housing is fixed upon the roof above the ventilation opening, then the shaft or spindle 70 upon which the fan and the driving rotor are mounted is introduced in the housing through the bearings and secured in position by an end disc or screw 71.

An advantageous attachment of the shaft common to the fan and the rotor results in a further development of my invention, if, as illustrated in the Figs. 7 and 8, the attachment means for the fan 235 and rotor 227 mounted at both sides of the bell 215 with their common shaft 270 are arranged at the head of the shaft viz. at the roof 271 of the fan or adjacent to it. The shaft may thus be provided with thread 272 at its head, a bushing 274 may be welded to the roof 271 or attached to it in any other suitable manner, thread and bushing being engaged to each other, for instance by holding the shaft at the slot of the screw or other suitable means of engagement, for instance a square or hexagonal portion, by means of a thin tool introduced into the bushing 274 and screwing the bushing 274 home together with the rotor

roof 271. The thread 272 is so chosen that the rotor is screwed in the same direction in which the motor turns during the operation of the ventilator, so that a loosening of the rotor on the thread 272 of the shaft need not be feared when the ventilator is working.

The head of the screw 272 at the head of the shaft may be protected against external influences and grabbing or tampering by a covering screw 273 provided above the screw 272 and consisting of a weather-proof material for instance such as brass or the like. The mounting of the device is extremely simple. First the sleeve 263 framing the ventilation opening is mounted upon the wall or roof for instance of a car (Fig. 10) by means of screws 265 passed through the openings 262. Then the shaft 270 with its bearings 251, 252 as well as the distance tube 280 or the washer 281 is inserted into the housing and there secured in place by the cap nut 285 which may be provided with suitable packing means, such as the packing disc 286. Now the base of the bell shaped housing together with the fan and rotor mounted upon it with the protective tube 275, if desired, is slipped over the shaft and fixed in the above described manner by screwing the bushing 274 mounted on the roof of the fan 271 on to the thread 272.

Various modifications and changes may be made without departing from the spirit and the scope of the invention, and I desire, therefore, that only such limitations shall be placed thereon as are imposed by the prior art.

I claim:—

1. In a ventilating device, in combination, a shaft, a driving rotor supported thereby and adapted to be driven by an air current flowing past said ventilating device, a fan also supported by said shaft and adapted to deliver air serving for the ventilation of the room to be ventilated, an axially curved air guiding means separating said rotor and fan, and disposed closely adjacent to said rotor, a central support adapted to serve as a base for said ventilating device and as an air intake for said device, said support having a centrally supported shaft bearing for rotatably supporting the entire device on said shaft, the air being exhausted by said device between the guiding means and said support.

2. In a ventilating device, in combination, a shaft, a driving rotor supported thereby and adapted to be driven by a current of air flowing past said ventilating device, a fan also supported by said shaft and adapted to deliver air serving for the ventilation of the room to be ventilated, a disc having a central bore through which said shaft passes, said rotor being located closely adjacent to one side of said disc and said fan being located closely adjacent to the other side of said disc, said disc forming a concave housing sur-

rounding the blades of said fan.

3. In a ventilating device, in combination, a shaft, a driving rotor supported thereby and adapted to be driven by a current of air flowing past said ventilating device, a fan also supported by said shaft and adapted to deliver air serving for the ventilation of the room to be ventilated, a disc having a central bore through which said shaft passes, said rotor being located closely adjacent to one side of said disc and said fan being located closely adjacent to the other side of said disc, said disc forming a concave housing, surrounding the blades of said fan, the blades of said fan being substantially radial to said shaft.

4. In a ventilating device, in combination, a shaft, a disc supported thereby and a driving rotor also supported by said shaft and adapted to be driven by a current of air flowing past said ventilating device, said driving rotor being located closely adjacent to one side of said disc, substantially radially extending blades fixed to the other side of said disc, said disc and said blades being adapted to deliver air serving for the ventilation of the room to be ventilated.

5. In a ventilating device, in combination, a shaft, a concave disc mounted thereon, and a driving rotor also mounted upon said shaft and adapted to be driven by a current of air flowing past said ventilating device, said driving rotor being located closely adjacent to the outside of said disc, substantially radially extending blades fixed in the hollow portion of said disc, said disc and said blades being adapted to move air serving for the ventilation of the room to be ventilated.

6. In a ventilating device, in combination, a shaft, a concave disc mounted thereon, and a driving rotor also mounted upon said shaft and adapted to be driven by a current of air flowing past said ventilating device, said driving rotor being located closely adjacent to the outside of said concave disc, substantially radially extending blades fixed within the concavity of said disc, the rim of said disc extending beyond the edges of said blades.

7. In a ventilating device, in combination, a shaft, a concave disc mounted thereon, and a driving rotor also mounted upon said shaft and adapted to be driven by a current of air flowing past said ventilating device, said driving rotor being located closely adjacent to the outside of said concave disc, substantially radially extending blades fixed to the hollow side of said concave disc, the rim of said disc extending beyond the free edges of said blades, said blade edges being outwardly inclined with respect to the plane of the rim of said disc.

8. In a ventilating device, in combination, a shaft, a concave disc mounted thereon, and a driving rotor also mounted on said shaft and adapted to be driven by a current of air

flowing past said ventilating device, said driving rotor being located closely adjacent to the outside of said concave disc, substantially radially extending blades fixed in the hollow portion of said concave disc, said disc and said blades being adapted to deliver the quantity of air serving for the ventilation of the room to be ventilated, and an annular disc covering the inner portion of the annular area defined by the rotation of the blade edges, the outer edge of said annular disc being located at a distance from the rim of said concave disc, the air delivered by said blades passing between the concave disc rim and said outer annular disc edge.

9. In a ventilating device, in combination, a shaft, a rotary disc mounted thereon, a driving rotor also mounted upon said shaft and adapted to be driven by a current of air flowing past said ventilating device, said driving rotor being located closely adjacent to one side of said disc, radially extending blades mounted upon the other side of said disc, said disc and said blades being adapted to deliver air serving for the ventilation of the room to be ventilated, and an annular disc mounted upon the edges of said blades and covering the inner portion of the annular area defined by the rotation of the blade edges, the outer edge of said annular disc being located at a distance from the periphery of said rotary disc.

10. In a ventilating device for ventilating a room or space, in combination, a shaft, a rotary disc mounted thereon, a driving rotor also mounted on said shaft and adapted to be driven by a current of air flowing past said ventilating device, said driving rotor being located adjacent to one side of said disc, blades upon the other side of said disc, said blades being adapted to move air serving for the ventilation of the room to be ventilated, an annular disc adjacent to the edges of said blades, and covering the inner portion of the annular area defined by the rotation of the blade edges, the outer edge of said annular disc being located at a distance from the periphery of said rotary disc, a supporting ring adapted to carry the said ventilating device, said ring being located adjacent to the central opening of said annular disc, a bearing box adapted to support said shaft, and means for mounting said bearing box upon said supporting ring, said bearing box forming a receptacle adapted to contain oil.

11. In a ventilating device, in combination, a shaft, a driving rotor supported thereby and adapted to be driven by a current of air flowing past said ventilating device, a fan also supported by said shaft and having substantially radially extending blades adapted to deliver air serving for the ventilation of the room to be ventilated, a disc having a central bore through which the said

shaft projects, said driving rotor being located adjacent to one side of said disc, said fan being located adjacent to the other side of said disc, said disc forming a concave housing, containing the blades of said fan, an annular disc adjacent to the edges of the blades remote from the inner roof of said concave housing and being directed towards the rim of said concave housing, the outer edge of said ring disc being located at some distance from the edge of said concave housing.

12. In a ventilating device, in combination, a shaft, a driving rotor supported thereby and adapted to be driven by a current of air flowing past said ventilating device, a fan also supported by said shaft and adapted to move air serving for the ventilation of the room to be ventilated, a disc having a central bore through which the said shaft projects, said driving rotor being located adjacent to one side of said disc, said fan being located adjacent to the other side of said disc, said disc forming a concave housing surrounding the blades of said fan, said blades being substantially radial to said shaft, an annular disc adjacent to the edges of the blades remote from the inner roof of said concave housing and being directed towards the rim of said concave housing, the outer edge of said ring disc being located at some distance from the edge of said concave housing, and a carrier ring adapted to support said ventilating device, said carrier ring being located adjacent to the central opening of said ring disc.

13. In a ventilating device, in combination, a shaft, a driving rotor supported thereby and adapted to be driven by a current of air flowing past said ventilating device, a fan also supported by said shaft and adapted to deliver air serving for the ventilation of the room to be ventilated, a disc having a central bore through which the said shaft projects, said driving rotor being located adjacent to one side of said disc, said fan being located adjacent to the other side of said disc, said disc presenting a cavity containing the blades of said fan, said blades being substantially radial to said shaft, an annular disc adjacent to the edges of the blades remote from the inner roof of said bell and directed towards the rim of said bell, the outer edge of said annular disc being located at some distance from the edge of the first-mentioned disc, a carrier ring adapted to support said ventilating device, and being located adjacent to the central opening of said ring disc and a bearing box adapted to support said shaft, said box being fixed to said ring in its central axis.

14. In a ventilating device, in combination, a shaft, a driving rotor supported thereby and adapted to be driven by a current of air flowing past said ventilating device, a fan also supported by said shaft and adapted to

70

75

80

85

90

95

100

105

110

115

120

125

130

deliver air serving for the ventilation of the room to be ventilated, a disc having a central bore through which the said shaft projects, said driving rotor being located adjacent to one side of said disc, said fan being located adjacent to the other side of said disc, said disc presenting a cavity housing the blades of said fan, said blades being substantially radial to said shaft, an annular disc adjacent to the edges of the blades remote from the inner roof of the first-mentioned disc and being directed towards the rim of the latter, the outer edge of said annular disc being located at some distance from the edge of the latter, a carrier ring adapted to support said ventilating device, and being located adjacent to the central opening of said ring disc, a bearing box adapted to support said shaft and being fixed to said ring in its central axis, and ball-bearings at the two ends of said bearing box adapted to journal and support said shaft.

15. In a ventilating device, in combination, a shaft, a driving rotor supported thereby and adapted to be driven by a current of air flowing past said ventilating device, a fan also supported by said shaft and adapted to move air serving for the ventilation of the room to be ventilated, a disc having a central bore through which the said shaft projects, said driving rotor being located adjacent to one side of said disc, said fan being located adjacent to the other side of said disc, said disc forming a cavity housing the blades of said fan, said blades being substantially radial to said shaft, an annular disc adjacent to the edges of the blades remote from the inner roof of the first-mentioned disc and being directed towards the rim of the latter, the outer edge of said annular disc being located at some distance from the edge of the first-mentioned disc, a carrier ring adapted to support said ventilating device, and being located adjacent to the central opening of said ring disc, a bearing box adapted to support said shaft and being fixed to said ring in its central axis, ball bearings disposed at the two ends of said bearing box for journalling and supporting said shaft, and a spacing sleeve on said shaft between said ball-bearings adapted to maintain the desired distance between said bearings.

16. In a conveyance, in combination, a roof, a carrier ring adapted to frame an opening in said roof, a bearing box fixed to said ring in its central axis, bearings in said bearing box, a shaft supported and journalled by said bearings, a disc supported by said shaft, a driving rotor supported by said shaft on one side of said disc and adapted to be driven by a current of air flowing past said ventilating device, and a fan supported by said shaft on the other side of said disc and adapted to deliver air serving for the ventilation

of the room to be ventilated.

17. In a conveyance, in combination, a roof, a carrier ring adapted to frame an opening in said roof, a bearing box fixed to said ring in its central axis, bearings in said bearing box, a shaft supported and journalled by said bearings, a disc supported by said shaft, a driving rotor supported by said shaft on one side of said disc and adapted to be driven by a current of air flowing past said ventilating device, and a fan supported by said shaft on the other side of said disc and adapted to deliver air serving for the ventilation of the room to be ventilated, said disc presenting a cavity adapted to house the blades of said fan.

18. In a conveyance, in combination, a roof, a carrier ring adapted to frame an opening in said roof, a bearing box fixed to said ring in its central axis, bearings in said bearing box, a shaft, supported and journalled by said bearings, a disc supported by said shaft, a driving rotor supported by said shaft on one side of said disc and adapted to be driven by a current of air flowing past said ventilating device, and a fan supported by said shaft on the other side of said disc and adapted to deliver air serving for the ventilation of the room to be ventilated, said disc presenting a cavity adapted to house the blades of said fan, the edge of said bell being located at some distance from the surface of said roof leaving an annular gap for the passage of the air delivered by said fan.

19. In a conveyance, in combination, a roof, a carrier ring adapted to frame an opening in said roof, a bearing box fixed to said ring in its central axis, bearings in said bearing box, a shaft, supported and journalled by said bearings, a disc mounted upon said shaft, vanes on the side of said disc facing away from said conveyance roof, said vanes being adapted to be moved by a current of air passing along said vehicle, fan blades on the side of said disc facing said vehicle roof, said blades being adapted to move air serving for the ventilation of said conveyance.

20. In a ventilating device for ventilating a room, in combination, a carrier ring adapted to frame an opening in the room wall, a bearing box fixed to said carrier ring in concentric axial alinement therewith, bearings in said bearing box, a shaft supported and journalled by said bearing, a disc mounted upon said shaft, vanes on the side of said disc facing away from said wall, the generatrix of the planes of said vanes being substantially parallel to said shaft, said vanes being adapted to be moved by a current of air passing past said wall, blades on the side of said disc facing said wall, said blades being disposed substantially radially to said shaft and being adapted to move air serving for the ventilation of the room.

21. In a ventilating device for ventilating

a room, in combination, a carrier ring adapted to frame an opening in the wall of the room to be ventilated, a bearing box fixed to said carrier ring in concentric axial alignment therewith, bearings in said bearing box, a shaft supported and journaled by said bearing, a disc mounted upon said shaft, two oppositely arranged hollow shaped vanes mounted on the side of the disc facing away from the wall, said vanes having a generally rectilinear generatrix, the inner edge of each vane extending to the segmental space bordered by the other vane, both vanes forming an air passage adapted to force the air current from the hollow side of one of said vanes to the hollow side of the other vane in an S-like path of substantially constant area, said vanes being adapted to be moved by a current of air passing along said wall, fan blades on the side of said disc facing said wall, said blades being adapted to move air serving for the ventilation of said room, and extending substantially radially to said shaft.

22. In a device for ventilating a room, in combination, a carrier ring, a bearing box fixed to said carrier ring in concentric axial alignment therewith, bearings in said bearing box, a shaft supported and journaled by said bearings, a disc mounted upon said shaft and provided with a central opening for the passage of said shaft, vanes mounted on one side of said disc and adapted to be rotated by a current of air passing said device, fan blades mounted on the other side of said disc and adapted to move air serving for the ventilation of said room, said vanes being spaced apart at the central portion of said disc, allowing said shaft to pass freely between them, a roof attached to the top of said vanes, a central hub on said roof, and means for attaching the upper free end of said shaft to said hub.

23. In a ventilating device, in combination, a shaft, a driving rotor supported thereby and adapted to be driven by an air current flowing past said ventilating device, a fan also supported by said shaft and adapted to deliver air serving for the ventilation of the room to be ventilated, an axially curved air guiding means separating said rotor and fan, and disposed closely adjacent to said rotor, and a support adapted to serve as a base for said ventilating device and as an air intake for said device, said support having a centrally supported shaft bearing for rotatably supporting said shaft, said rotor and said fan, the air being exhausted by said device between said guiding means and said support.

In testimony whereof I affix my signature.

ANTON FLETTNER.

CERTIFICATE OF CORRECTION.

9

Patent No. 1,773,453.

Granted August 19, 1930, to

ANTON FLETTNER.

It is hereby certified that error appears in the printed specification of the above numbered patent requiring correction as follows: Page 1, line 34, for the word "particular" read particularly; line 64, for "construction" read constructions, and line 75, for "present" read represent; page 7, line 15, claim 14, strike out "latter" and insert first mentioned disc; and that the said Letters Patent should be read with these corrections therein that the same may conform to the record of the case in the Patent Office.

Signed and sealed this 21st day of October, A. D. 1930.

M. J. Moore,
Acting Commissioner of Patents.

(Seal)