



(51) International Patent Classification:

G08B 13/14 (2006.01) A47F 5/08 (2006.01)
G08B 13/22 (2006.01) E05B 47/00 (2006.01)
A47F 5/00 (2006.01) E05B 73/00 (2006.01)

(21) International Application Number:

PCT/US2018/015000

(22) International Filing Date:

24 January 2018 (24.01.2018)

(25) Filing Language:

English

(26) Publication Language:

English

(30) Priority Data:

62/450,371 25 January 2017 (25.01.2017) US
62/589,712 22 November 2017 (22.11.2017) US

(71) Applicant: INVUE SECURITY PRODUCTS INC.

[US/US]; 9201 Baybrook Lane, Charlotte, NC 28277 (US).

(72) Inventors: HELMAN, Christopher, Richard; 4908

Rankin Place, Charlotte, NC 28277 (US). BAKER, Kyle; 7622 Caspian Drive, Washaw, NC 28277 (US). PHILLIPS, Jonathon, D.; 5040 Timber Falls Drive, Fort Mill, SC 29707 (US). DUGAS, Daniel, G.; 529 North Graham Street, Unit 1C, Charlotte, NC 28202 (US). JOHNSON, Michael, R.; 8003 Avanti Drive, Waxhaw, NC 28173 (US). SYMONS, Daniel, C.; 7910 Kington Drive, Waxhaw, NC 28173 (US). VAN LANDINGHAM, A., Reneau; 4065 Mountain View Street, Gastonia, NC 28056 (US). BRUTKE, Eric; 1056 Palmyra Drive, Tega Cay, SC 29708 (US).

(74) Agent: KIRK, Trent, A.; Invue Security Products Inc.,

9201 Baybrook Lane, Charlotte, NC 28277 (US).

(81) Designated States (unless otherwise indicated, for every

kind of national protection available): AE, AG, AL, AM, AO, AT, AU, AZ, BA, BB, BG, BH, BN, BR, BW, BY, BZ, CA, CH, CL, CN, CO, CR, CU, CZ, DE, DJ, DK, DM, DO, DZ, EC, EE, EG, ES, FI, GB, GD, GE, GH, GM, GT, HN,

(54) Title: MERCHANDISE SECURITY SYSTEM

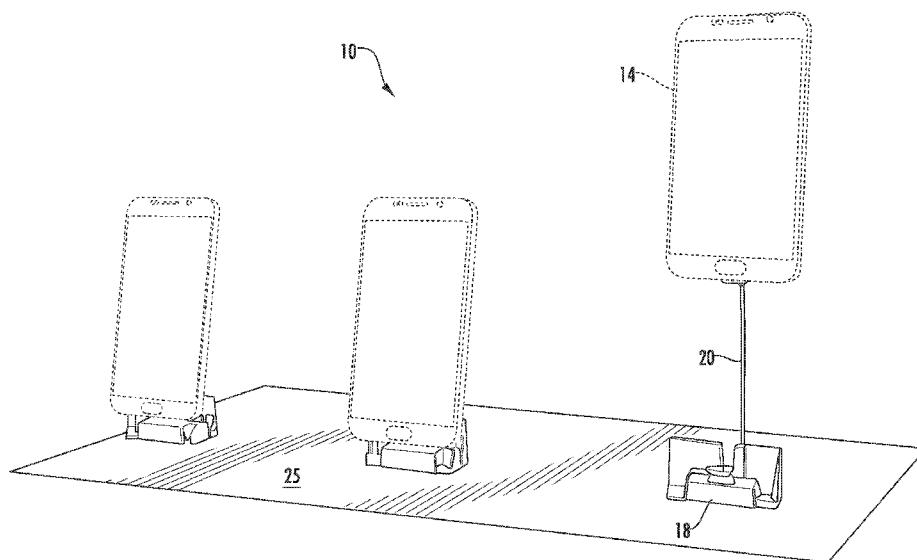

FIG. 1

(57) Abstract: Embodiments of the present invention are directed to security systems for securing an item of merchandise from theft or unauthorized removal. For example, the security system may include a sensor configured to be coupled to the item of merchandise, wherein the sensor includes an electrical connector. The security system also includes a base configured to removably support the sensor thereon, wherein the base includes an electronics module having a connector. The connector of the sensor and the connector of the electronics module are configured to electrically connect with one another when the sensor is supported on the base, and the sensor is configured to detect unauthorized removal of the item of merchandise from the sensor.



HR, HU, ID, IL, IN, IR, IS, JO, JP, KE, KG, KH, KN, KP, KR, KW, KZ, LA, LC, LK, LR, LS, LU, LY, MA, MD, ME, MG, MK, MN, MW, MX, MY, MZ, NA, NG, NI, NO, NZ, OM, PA, PE, PG, PH, PL, PT, QA, RO, RS, RU, RW, SA, SC, SD, SE, SG, SK, SL, SM, ST, SV, SY, TH, TJ, TM, TN, TR, TT, TZ, UA, UG, US, UZ, VC, VN, ZA, ZM, ZW.

(84) Designated States (*unless otherwise indicated, for every kind of regional protection available*): ARIPO (BW, GH, GM, KE, LR, LS, MW, MZ, NA, RW, SD, SL, ST, SZ, TZ, UG, ZM, ZW), Eurasian (AM, AZ, BY, KG, KZ, RU, TJ, TM), European (AL, AT, BE, BG, CH, CY, CZ, DE, DK, EE, ES, FI, FR, GB, GR, HR, HU, IE, IS, IT, LT, LU, LV, MC, MK, MT, NL, NO, PL, PT, RO, RS, SE, SI, SK, SM, TR), OAPI (BF, BJ, CF, CG, CI, CM, GA, GN, GQ, GW, KM, ML, MR, NE, SN, TD, TG).

Declarations under Rule 4.17:

— *of inventorship (Rule 4.17(iv))*

Published:

— *with international search report (Art. 21(3))*

MERCHANDISE SECURITY SYSTEM

CROSS REFERENCE TO RELATED APPLICATIONS

[0001] This application claims the benefit of priority to U.S. Provisional Application No. 62/450,371 filed on January 25, 2017, and U.S. Provisional Application No. 62/589,712 filed on November 22, 2017, the entire disclosures of which are incorporated herein by reference.

BACKGROUND OF THE INVENTION

[0002] Embodiments of the present invention relate generally to security systems for protecting items of merchandise, such as consumer electronics products.

[0003] It is common practice for retailers to provide demonstration models of relatively expensive consumer electronics products, such as handheld devices, tablets, and laptop computers, so that a potential purchaser may examine the product more closely and test the operation of its features. A working demonstration model, however, increases the possibility that the demonstration model will be stolen or removed from the display area by an unauthorized person. As a result, demonstration models of consumer electronics products are typically protected by a security system that permits a potential purchaser to examine and operate the product, while reducing the likelihood that the demonstration model will be stolen or removed from the display area.

[0004] The security system displays an item of merchandise so that a potential purchaser can readily view and, in some instances, operate the item when making a decision whether to purchase the item. At the same time, the item of merchandise is usually physically secured on the security system so as to prevent, or at least deter, theft of the item. The merchandise display security system may also include an alarm that is activated to alert store personnel in the event that a shoplifter attempts to separate the item of merchandise from the security system.

BRIEF SUMMARY

[0005] Embodiments of the present invention are directed towards security systems, sensor assemblies, and methods for securing an item of merchandise from theft or unauthorized removal. In one embodiment, a security system includes a bracket configured to be attached to an item of merchandise and a sensor configured to releasably engage the bracket. The security system also includes a flexible circuit with a connector configured to removably engage an input port of the item of merchandise and configured to be in electrical communication with the sensor, wherein the sensor is configured to detect

unauthorized removal of the sensor or the connector from the item of merchandise.

[0006] In one embodiment, a sensor assembly includes a bracket configured to be attached to an item of merchandise and a sensor configured to releasably engage the bracket such that the sensor is removable from the bracket. The sensor assembly further includes a bracket assembly having at least one bracket arm configured to engage a side of the item of merchandise, wherein the bracket assembly is configured to prevent removal of the sensor from the bracket.

[0007] In one embodiment, a method includes attaching a bracket to an item of merchandise and engaging a sensor with the bracket. The method also includes engaging a connector of a flexible circuit with an input port of the item of merchandise to establish electrical communication with the sensor, wherein the sensor is configured to detect unauthorized removal of the sensor or the connector from the item of merchandise.

[0008] In another embodiment, a security system includes a sensor configured to be coupled to the item of merchandise, the sensor comprising an electrical connector, and a base configured to removably support the sensor thereon, the base comprising an electronics module having an electrical connector. The electrical connector of the sensor and the electrical connector of the electronics module are configured to electrically connect with one another when the sensor is supported on the base, and the sensor is configured to detect unauthorized removal of the item of merchandise from the sensor.

BRIEF DESCRIPTION OF THE DRAWINGS

[0009] FIG. 1 is a perspective view of a security system according to one embodiment of the present invention.

[0010] FIG. 2 is a rear perspective view of a sensor and a base of the security system shown in FIG. 1.

[0011] FIG. 3 is an enlarged perspective view of a sensor of the security system shown in FIG. 1.

[0012] FIG. 4 is a front perspective view of a sensor and a base shown in FIG. 1 coupled with a cable.

[0013] FIG. 5 is a perspective view of a security system according to one embodiment of the present invention.

[0014] FIG. 6 show front and rear perspective views of a sensor and a base of the security system shown in FIG. 5.

[0015] FIG. 7 is a perspective view of a security system including an alarm unit according to one embodiment of the present invention.

- [0016] FIG. 8 is a front perspective view of a security system including a power box according to one embodiment of the present invention.
- [0017] FIG. 9 is a schematic illustrating a security system securing a plurality of items of merchandise and including a power box and a hub according to one embodiment of the present invention.
- [0018] FIG. 10 is a side perspective view of a security system including a recoiler according to one embodiment of the present invention.
- [0019] FIG. 11 is a front perspective view of the recoiler shown in FIG. 10.
- [0020] FIG. 12 is another front perspective view of the recoiler shown in FIG. 10 with a connector disconnected therefrom.
- [0021] FIG. 13 is a top perspective view of a security system according to another embodiment of the present invention.
- [0022] FIG. 14 is a plan view of a flexible circuit and a connector according to one embodiment of the present invention.
- [0023] FIG. 15 is a rear perspective view of a security system according to another embodiment of the present invention.
- [0024] FIG. 16 is a rear perspective view of a security system according to another embodiment of the present invention.
- [0025] FIG. 17 is a front perspective view of the security system shown in FIG. 15 with the item of merchandise lifted off of the base.
- [0026] FIG. 18 is an enlarged perspective view of a sensor of the security system shown in FIG. 15.
- [0027] FIG. 19 is an enlarged perspective view of the sensor shown in FIG. 18 removed from a bracket.
- [0028] FIG. 20 is a front perspective view of a sensor of the security system shown in FIG. 15.
- [0029] FIG. 21 is a front perspective view of the sensor shown in FIG. 20 with the bracket removed.
- [0030] FIG. 22 is a front perspective view of the bracket shown in FIG. 20 with the sensor removed.
- [0031] FIG. 23 is a front perspective view of a security system according to another embodiment of the present invention.
- [0032] FIG. 24 is rear perspective view of the security system shown in FIG. 23 illustrating a sensor and a base.
- [0033] FIG. 25 is an enlarged rear view of a bracket and bracket arms of the security system shown in FIG. 23.
- [0034] FIG. 26 is a perspective view of a recoiler of the security system shown in FIG. 23.

[0035] FIG. 27 is another perspective view of the recoiler of the security system shown in FIG. 23.

[0036] FIG. 28 is a perspective view of a security system according to another embodiment of the present invention.

DETAILED DESCRIPTION OF EMBODIMENTS OF THE INVENTION

[0037] Referring to the accompanying figures wherein identical reference numerals denote the same elements throughout the various views, embodiments of security systems according to the present invention for protecting an item of merchandise against theft or unauthorized removal are disclosed. The item of merchandise may be any item, including any number of consumer electronics products (e.g. hand-held device, cellular phone, smart phone, tablet, laptop computer, wearables, etc.). The security systems described herein are operable for securing the item of merchandise against theft or authorized removal, while at the same time permitting a potential purchaser to closely examine and operate the item of merchandise in a display area. The security system permits a potential purchaser to examine and test the item of merchandise, while reducing the likelihood that the item of merchandise will be stolen or removed from the display area by an unauthorized person. The systems shown and described herein are suitable for securing an item of merchandise in a residential or commercial environment, as well as a retail environment, and furthermore, is not intended to be limited to use only as a security display device for protecting against theft and/or unauthorized removal.

[0038] According to one embodiment shown in FIGS. 1-3, a security system 10 generally comprises a sensor 12 configured to be secured to an item of merchandise 14. The sensor 12 may be electrically connected to a connector 17 that is configured to electrically connect to an input jack of the item of merchandise 14. The security system 10 may also include a base 18 that is configured to removably support the sensor 12 and the item of merchandise 14 thereon. In some embodiments, the security system 10 may also include a cable 20 that is coupled to the sensor 12 at one end and operably engaged with a recoiler 22 at an opposite end (see, e.g., FIG. 10). As explained in further detail below, in one embodiment a sense circuit or loop is defined through the cable 20 and may be used to detect various security events associated with the cable 20, such as the cable being cut, shorted, and/or disconnected. The cable 20 may also allow for charging of the item of merchandise 14 and/or power source carried by the sensor 12. The sensor 12 may detect security events associated with the sensor and/or the item of merchandise 14, such as the item of merchandise being removed from the sensor.

[0039] The sensor 12 may be secured to the item of merchandise 14 using any desired technique, such as an adhesive and/or mechanical brackets. The sensor 12 may have a variety of shapes and sizes for

being secured to the item of merchandise 14. As shown in FIG. 2, the sensor 12 may only be secured to a rear surface of the item of merchandise 14. In some cases, the sensor 12 is configured to support the item of merchandise 14 in a desired display orientation (e.g., a vertical orientation). In addition, the connector 17 may be configured to be removably inserted into the input jack of the item of merchandise 14. Thus, the sensor 12 and the item of merchandise 14 may be electrically connected via the connector 17. The sensor 12 may include a printed circuit board (PCB), circuitry, or the like. For example, the sensor 12 may include charging circuitry for facilitating power transfer between the base 18 and the item of merchandise 14.

[0040] The connector 17 may be electrically connected to the PCB in the sensor 12 using various techniques, such as via a cable or a flexible circuit. In one embodiment, a flexible circuit 24 includes one or more conductors and is electrically connected to the PCB at one end and the connector 17 at the opposite end, such as via direct soldering the flexible circuit to both the PCB and the connector (see, e.g., FIG. 14). The flexible circuit 24 eliminates the need for a separate external cable extending from the sensor 12 to the item of merchandise 14, while facilitating electrical communication with the item of merchandise. The flexible circuit 24 itself also does not include a PCB and therefore may only include one or more conductors disposed within a flexible substrate. Moreover, the flexible circuit 24 has a low profile that allows the footprint of the sensor 12 to remain small, as well as allow flexibility in routing the connector 17 to various locations on the item of merchandise. Thus, rather than using a conventional cable (e.g., a round or helical cable), the flexible circuit 24 provides a very low profile connection between the sensor 12 and the connector 17. In some examples, the flexible circuit 24 may have a width of less than 5 mm, less than 3 mm, or less than 1 mm. In other examples, the flexible circuit 24 may have an aspect ratio (width-to-thickness) of at least 2, at least 3, at least 4, at least 5, or at least 10. In one example shown in FIG. 3, the flexible circuit 24 extends from the connector 17 and conforms to a rear surface and/or a bottom edge of the item of merchandise 14. In this example, the sensor 12 is only located on the rear surface of the item of merchandise. In the illustrated embodiment, the connector 17 is mounted to and extends from the sensor 12 but could be positioned at other locations depending on the location of the input port of the item of merchandise 14.

[0041] The base 18 or display stand may be configured to be supported by a fixed support or display surface 25, such as a counter, shelf, fixture, or the like. The base 18 may be secured to the support surface using any desired technique such as an adhesive, brackets, and/or fasteners. In one embodiment shown in FIG. 2, the base 18 may include an electronics module 26. It is understood that the base 18 and electronics module 26 may be separate components and mated together or may be integrated into a single

component in some cases. Thus, in some cases, the base 18 may not include any electrical components. The base 18 or electronics module 26 may include one or more electrical contacts 38 for electrically communicating with the sensor 12, as described in greater detail below.

[0042] Moreover, FIG. 2 shows that the electronics module 26 may include an auxiliary port 36 for connecting to corresponding auxiliary devices for the item of merchandise 14. Thus, in addition to communicating with an item of merchandise 14, the electronics module 26 may be configured to electrically connect to an auxiliary device, such as, for example, an auxiliary device for the item of merchandise 14 on display (e.g., a stylus, speaker, keyboard, Bluetooth device, etc.). The auxiliary port 36 may be an input port (e.g., a micro-USB or USB-C port) that is configured to receive a corresponding input connector on the auxiliary device (see, e.g., FIG. 9). When the auxiliary device is connected to the auxiliary port 36, the auxiliary port may be configured to receive power, if necessary, and/or define a sense loop that may be used to detect various security events associated with the auxiliary device, such as the auxiliary device being removed from the base 18 or electronics module 26 in an unauthorized manner. The auxiliary port 36 may be part of the same sense loop defined with the sensor 12 and the cable 20, or may define a separate sense loop. In the instance where the auxiliary port 36 is configured to provide power, a power box 40 (discussed below) may be configured to determine the power requirements of the auxiliary device and provide the necessary power level to effectuate charging. Therefore, the auxiliary port 36 allows an auxiliary device to be displayed and used by a prospective consumer in connection with an item of merchandise 14, while the retailer is able to also power and protect both the item of merchandise 14 and the auxiliary device from theft with a single security device rather than requiring two separate security devices.

[0043] As shown in FIGS. 1 and 10, the base 18 may be configured to support the item of merchandise in a vertical orientation. The base 18 may be configured to support the item of merchandise in a vertical orientation despite the sensor only be located on a rear surface of the item. For instance, FIG. 13 demonstrates that the sensor 12 and the base 18 may engage with one another in a dovetail fit. Thus, each of the sensor 12 and base 18 may have a dovetail shape that are configured to mate with one another. In this way, when the base 18 receives the sensor 12, the sensor is supported in both an X- and Y-direction, which not only provides a “clean” appearance to a customer, but also provides additional stability when the sensor is supported on the base.

[0044] The security system 10 may include a recoiler 22 and a cable 20 as discussed above. The base 18 may include an opening for receiving the cable 20. As such, the cable 20 may be extended through the opening when the sensor 12 and the item of merchandise 14 are lifted from the base, and the

cable may be retracted through the opening when the sensor and the item of merchandise are returned to the base. The recoiler 22 may be spring biased in some embodiments such that the cable 20 is automatically retracted within the recoiler. The recoiler 22 may be mounted to an underside of the support surface 25 (see, e.g., FIG. 12). The cable 20 may include one or more electrical conductors extending along the length of the cable. In some cases, the cable 20 may include a pair of conductors for defining a sense loop or circuit and conducting an electrical signal. In other cases, the cable 20 may include a single conductor, such as an optical conductor for conducting an optical signal (e.g., a fiber optic cable).

[0045] In one embodiment shown in FIG. 11, an end of the cable 20 opposite the sensor 12 may include a connector 32 configured to releasably engage the recoiler 22 for establishing electrical communication therebetween. For example, the recoiler 22 and connector 32 may be a USB-type connector. Advantageously, the connector 32 is sized to be routed through an opening defined in the display surface 25 and connected to the recoiler 22. In some cases, the connector 32 is configured to releasably engage a spool 34 located within the recoiler 22, wherein the cable 20 is configured to be wound from and onto the spool. The recoiler 22 may include a switch or latch to maintain the spool 34 within the recoiler in a fixed position when connecting and disconnecting the connector 32.

[0046] In one embodiment, the security system 10 includes an alarm unit 30. The alarm unit 30 may be a standalone component (see, e.g., FIG. 7) or may be housed by the sensor 12 or the base 18. Furthermore, the alarm unit 30 may include a PCB, circuitry, or the like that is in electrical communication with the cable 20. The alarm unit 30 is configured to generate a security signal in response to various security events, such as generating and audible and/or a visual alarm. Various sensing techniques may be employed for determining whether the cable 20 has been cut or removed from the sensor 12 in an unauthorized manner. For example, the cable 20 may include a pair of electrical conductors that define a sense loop therethrough. Thus, should the sense loop be interrupted (e.g., by cutting or shorting the cable 20), the alarm unit 30 may detect the interruption and generate a security signal. For example, the alarm unit 30 may be configured to generate an audible alarm. The alarm unit 30 may be configured to be armed and/or disarmed via a key, such as a wireless key. For instance, FIG. 7 shows that the alarm unit may include a wireless 33 interface for communicating with a key.

[0047] In some embodiments, the electronics module 26 and the sensor 12 include one or more contacts 28, 40 for facilitating the transmission of electrical, security, data and/or communication signals when the sensor is supported on the base. In some embodiments, the sensor 12 includes electrical contacts 28 in the form of a connector as shown in FIG. 3. For instance, the electrical contacts may be a

USB connector, such as a USB-C or micro-USB connector. The electrical contacts 28 may be in electrical communication with the PCB in the sensor 12 and the connector 17. Alternatively, the electrical contacts 28 may be electrically connected to only the PCB or the connector 17. In some embodiments, the sensor 12 may not supply power to the item of merchandise 14 when the item is lifted from the base 18. Rather, the item of merchandise 14 may operate using its own power source when lifted from the base 18.

[0048] As discussed above, the base 18 or electronics module 26 may include one or more electrical contacts 40. In one embodiment, the contacts 40 of the electronics module 26 may be in the form of a connector, similar to the sensor 12 described above. For example, the sensor 12 may include a female connector while the electronics module 26 includes a male connector. The contacts 28, 40 of the electronics module 26 and the sensor 12 are configured to align and mate with one another when the sensor is supported on the base 18. Thus, the electronics module 26 and the sensor 12 are in electrical communication with one another when the sensor is supported on the base 18. The electronics module 26 may be electrically connected to a power source which is configured to provide power to the electronics module 26 and/or the one or more electrical contacts 40 in the electronics module. The electronics module 26 may also include charging circuitry that is configured to facilitate power transfer from the external power source and the electrical contacts 40. Thus, when the sensor 12 is supported on the base 18, power is able to be transferred between the contacts 28, 40 and to the sensor 12. The connector 17 is electrically connected to the sensor contacts 28 as power is delivered such that power is provided to the item of merchandise 14. Therefore, the item of merchandise 14 may be powered by power transferred thereto and may be used to charge a battery associated with the item of merchandise. Although the aforementioned embodiments describe that power may be transferred via electrical contacts, it is understood that other techniques could be used to transfer power to sensor 12 and the item of merchandise 14. For example, inductive charging functionality could be employed for transferring power.

[0049] It is understood that the cable 20 may be any suitable cord, tether, or the like. In addition, the cable 20 may include one or more electrical conductors for transmitting electrical, security, data and/or communication signals. In addition, the cable 20 may be a single strand, multi-strand, or braided. The cable 20 may be flexible to facilitate extension and retraction relative to the recoiler 22, and in some embodiments, may be formed of a cut-resistant material. Furthermore, the cable 20 may have various cross sections, such as round or flat. In some embodiments, the security system 10 may not include a recoiler 22. Thus, the cable 20 could be a straight or coiled cable that is coupled to the sensor 12 at one end and electrically connected to the base 18 or alarm unit 30 at an opposite end (see, e.g., FIG. 4).

[0050] An end of cable 20 may be secured to the sensor 12. It is understood that the end of the cable 20 may be coupled to the sensor 12 using a variety of techniques, such as via a removable connector. In one embodiment, an end of cable 20 may be electrically secured to the sensor 12. The cable 20 may be electrically connected to the sensor 12 for defining a sense loop therethrough, such as via connector 17. For example, the sense loop may be interrupted in response to the connector 17 being removed from the item of merchandise. In some cases, the end of the cable 20 may include a connector that is configured to be releasably secured to the sensor 12, or the cable may be hardwired to the sensor in other embodiments. In one embodiment, the end of the cable 20 may be configured to rotate or swivel relative to the sensor 12 while still providing an electrical connection therebetween.

[0051] FIGS. 5-6 show an additional embodiment of a security system. The embodiment shown in FIGS. 5-6 may be used for larger items of merchandise 14 such as tablets or the like and function in a similar manner as that described above. As before, the security system includes a sensor 12 secured to an item of merchandise 14 with a connector 17. The base 18 may also include an electronics module 26 as discussed above. In this case, the electronics module 26 is disposed on an upper surface of the base 18 and may be configured to rotate relative to the base. For example, the electronics module 26 may be configured to rotate at least between landscape and portrait orientations while the sensor 12 is supported on the electronics module. As shown in FIG. 6, it can be seen that electrical contacts 40 may be disposed within the electronics module 26. Both the sensor 12 and the electronics module 26 may include mating geometry to facilitate alignment of the sensor on the electronics module.

[0052] In one embodiment, the security system 10 includes a power box 40 that is configured to electrically connect to the electronics module 26. The power box 40 may also be electrically connected to an alarm unit 30 or device for disarming the security system. In some instances, the electronics module 26 may include a cable 42 and an associated connector 44 at its end that is configured to releasably engage the power box 40. For example, the connector 44 may be a USB connector such as a USB-C connector. The power box 40 includes one or more input ports 46 for receiving the connector 44. The power box 40 may be configured to communicate with the sensor 12, item of merchandise 14, and or the electronics module 26. In some embodiments, the power box 40 is configured to adapt an input voltage input into the power box to the power requirements of the item of merchandise 14 and to output the adapted voltage to the electronics module 26. In one example, the connector 44 is a USB-C connector that allows for data, security, and power signals to be communicated between the power box 40 and the electronics module 26. The power box 40 may also be configured to utilize the USB Power Delivery (PD) specification for providing power to the item of merchandise 14. In this regard, the power box 40

and the item of merchandise may be configured to communicate with one another to determine the power requirements of the item of merchandise and to then provide the appropriate voltage to the item of merchandise. As shown in FIG. 9, the power box 40 may also be configured to communicate with a hub 48, which may be used to collect, communicate, and/or transfer various data to and from the security system 10 and any number of remote devices. For example, the hub 40 may be configured to collect data from the item of merchandise 14 to determine the make and model and/or collect data regarding the status of the security system. In some embodiments, the power box 40 may include an AC/DC voltage converter for converting an input AC voltage to the desired DC voltage. Thus, the power box 40 may allow for the elimination of a separate AC power source and AC/DC voltage converter. Integrating the voltage converter within the power box 40 may reduce cost of the security system, reduce inefficiencies in power delivery, and reduce the amount of space required by the security system.

[0053] FIGS. 15-19 illustrate additional embodiments of a security system 10'. In the embodiments shown in FIGS. 15-19, the security system 10' includes a sensor assembly 12' removably supported on a base 18'. The sensor assembly 12' includes a bracket or sled 50 configured to removably engage a sensor 52. The sensor 52 may be connected to a cable 20 similar to that described above. For example, the cable 20 may be coupled to the sensor 52 at one end (e.g., hardwired thereto) and operably engaged with a recoiler 22 at an opposite end. Furthermore, as shown in FIG. 15, the sensor 52 and base 18' may be sized and configured to mate with one another in a sliding engagement such that an outer surface of the sensor is flush to an outer surface of the base in at least one plane. Moreover, the base 18' may be a standalone component as shown in FIG. 15 or may be housed or otherwise integrated with a module 56 that is configured to contain the recoiler 22 therein. Thus, the module 56 may be configured to be positioned on a display surface 25 as opposed to positioning the recoiler 22 below the display surface.

[0054] The bracket 50 may be secured to the item of merchandise 14 with any one or combination of adhesives, fasteners, or brackets. The bracket 50 is configured to remain on the item of merchandise 14 when the sensor 52 is removed, which may be useful for remerchandising or daily removal of the item of merchandise for safe storage after business hours in a retail store. The sensor 52 may be configured to slidably engage the bracket 50 in some cases, e.g., in a dovetail type engagement. In the illustrated example, the bracket 50 is configured to be secured to a rear surface of the item of merchandise 14, and the sensor 52 is configured to slide in the same plane as the bracket and the rear surface to engage the bracket.

[0055] Moreover, the sensor 52 may lock to the bracket 50 when in engagement therewith. For example, as shown in FIG. 21 the sensor 52 may include a lock mechanism 54 that is configured to

engage the bracket 50 such that a key is required in order to unlock the lock mechanism prior to removing the sensor from the bracket. The lock mechanism 54 may include one or more engagement members 64 configured to releasably engage one or more associated engagement members 64 of the bracket 50. In some embodiments, the lock mechanism 54 is magnetically actuated such that a magnetic key is needed to disengage the lock mechanism from the bracket. In one instance, the lock mechanism 54 is biased towards a locked position such that the lock mechanism automatically engages the bracket 50 when the sensor is moved to an engaged position with the bracket. Moreover, the sensor 52 may include a switch 58 for detecting removal of the sensor from the item of merchandise 14 and/or the bracket 50. In one example, the lock mechanism 54 may be integrated with the switch 58 in a single component for detecting removal of the sensor.

[0056] As also similar to the embodiments described above, the sensor 52 may include a low profile flexible circuit 24 and associated connector 17. In this embodiment, the flexible circuit 24 and the sensor 52 may be configured to electrically connect to one another when the sensor is in engagement with the bracket 50. For instance, an end of the flexible circuit 24 may include one or more electrical contacts 60 that are configured to align with and contact one or more electrical contacts 66 on the sensor (e.g., contacts on PCB 62) when the sensor is in engagement with the bracket 50 for establishing an electrical connection between the connector 17, flexible circuit 24, sensor 52, and the cable 20. Thus, because the flexible circuit 24 is not soldered to the PCB 62 of the sensor, the flexible circuit 24 and associated connector 17 may be modular and capable of being swapped out for different types of items of merchandise 14 that have different input connector types.

[0057] FIGS. 23-27 illustrate a security system 100 according another embodiment of the present invention. In this embodiment, the security system 100 includes a sensor 52 and a base 18' similar to that described above. However, FIGS. 24-25 show that the security system 100 includes a bracket assembly comprising at least one bracket arm 102 configured to engage the item of merchandise 14. In this particular example, a pair of bracket arms 102 are shown and are configured to engage the sides of the item of merchandise 14. In some cases, the bracket arms 102 are connected by a rod 104 or like connection member, and the bracket arms 102 may be adjustable relative to one another along the rod. For instance, one or more adjustment members 106 may be used to adjust the location of the bracket arms 102, such as be rotation of a fastener engaged with the rod. Thus, rotation of the fastener in a clockwise or counterclockwise direction may adjust the position of the bracket arm 102 on the rod. One adjustment member 106 could be used to adjust the location of the bracket arms 102, or each bracket arm may have its own adjustment member.

[0058] In some embodiments, the bracket 50 is in engagement with the rod 104 as shown in FIG. 25. As shown, the bracket 50 may include one or more engagement members 106 configured to receive the rod 104. Thus, when the sensor 52 is removed from the bracket 50, the bracket arms 102 and rod 104 may remain attached to the item of merchandise 14. Furthermore, in some cases, the rod 104 and/or bracket arms 102 may block removal of the sensor 52 from the bracket 50. For instance, the bracket arms 102 and rod 104 may be assembled to the bracket 50 after the sensor 52 engages the bracket. Therefore, due to the size and location of the bracket 50 and the rod 104, the sensor 52 is unable to be slid out of engagement with the bracket 50 since the bracket and/or the rod prohibits sliding movement of the sensor relative to the bracket.

[0059] FIGS. 26-27 illustrate another embodiment of a recoiler 22'. In this embodiment, the recoiler 22' includes at least one roller 110 that is configured to guide the cable 20 as the cable is extended and retracted from the recoiler. In some cases, the roller 110 is elongated. As illustrated, the length of the roller 110 may be greater than at least half of the width of the recoiler 22'. In this way, the cable 20 is able to exit the recoiler 22' at any number of locations and provides more flexibility in where the recoiler is able to be located relative to a support surface 25, wherein there may be various obstructions or space limitations for the recoiler. In some embodiments, the recoiler 22' may include a bracket 112 that is attachable to the recoiler and includes a guide member 114 to facilitate a desired exit location of the cable 20 (e.g., at one end of a side of the recoiler). It is understood that different brackets 112 and guide members 114 may be employed depending on the desired exit location of the cable 20. In addition, the location of the bracket 112 could be flipped 180 degrees and attached to the recoiler 22' to facilitate an exit location at the center of one side of the recoiler. Furthermore, in some embodiments, the recoiler 22' includes a plurality of rollers 110, which may allow for even greater flexibility of the position of the recoiler and the exit location of the cable 20. For example, the rollers 110 may allow the recoiler 22' to be flipped 180 degrees horizontally and attached to the support surface 25.

[0060] In another embodiment shown in FIG. 28, the base 18' may be configured to be secured directly to the item merchandise 14 and is also configured to be engaged by the sensor 12'. This embodiment may be useful with larger items of merchandise 14, such as tablets. The sensor 12' and the base 18' may in turn be configured to be placed on and supported by a display surface 25 or a separate base supported on the display surface. In this example, the sensor 12' and/or the base 18' may be electrically connected to the flexible circuit 24 and connector 17 with a cable 120 via a connection member 122. For instance, the base 18' may be electrically connected to the cable 120, and the sensor 12' may be electrically connected to the cable 20. In some cases, the cable 120 may be connected to the

flexible circuit 24 with a connection member 122 comprising an over mold whereby the electrical conductors of the flexible circuit and the cable are electrically connected to one another (e.g., via soldering). In this way, the flexible circuit 24 is electrically connected to the cable 120, wherein the flexible circuit and the cable are different shapes and arrangement of conductors. The connection member 122 could be attached directly to the item of merchandise 14, such as with an adhesive. The connection member 122 may be formed of a flexible material. The cable 120 and the connection member 122 may allow for more flexible positioning of the sensor 12' relative to the item of merchandise 14, and use of a cable 120 may be easier to route and less susceptible to wear rather than routing the flexible circuit 24 to the sensor 12'.

[0061] The foregoing has described one or more embodiments of security systems for securing an item of merchandise from theft or unauthorized removal. Although various embodiments of the present invention have been shown and described, it will be apparent to those skilled in the art that various modifications thereto can be made without departing from the spirit and scope of the invention. Accordingly, the foregoing description is provided for the purpose of illustration only, and not for the purpose of limitation.

That which is claimed is:

1. A security system for securing an item of merchandise from theft or unauthorized removal, the security system comprising:
 - a bracket configured to be attached to an item of merchandise;
 - a sensor configured to releasably engage the bracket; and
 - a flexible circuit with a connector configured to removably engage an input port of the item of merchandise and configured to be in electrical communication with the sensor,wherein the sensor is configured to detect unauthorized removal of the sensor or the connector from the item of merchandise.
2. The security system of Claim 1, wherein the sensor is configured to releasably engage the bracket with a lock mechanism.
3. The security system of Claim 2, wherein the lock mechanism is configured to be magnetically actuated.
4. The security system of Claim 2, wherein the lock mechanism is biased towards a locked position.
5. The security system of Claim 1, wherein the flexible circuit is configured to establish an electrical connection with the sensor when the sensor is engaged with the bracket.
6. The security system of Claim 1, wherein the flexible circuit is releasably engaged with the sensor.
7. The security system of Claim 1, wherein the sensor is configured to slidably engage the bracket.
8. The security system of Claim 1, wherein the flexible circuit does not comprise a round or helical cable.
9. The security system of Claim 1, wherein the flexible circuit is configured to extend outwardly from the sensor and to the connector.
10. The security system of Claim 1, wherein the sensor is configured to detect unauthorized removal of the connector from the input port.
11. The security system of Claim 10, further comprising a cable electrically connected to the sensor, the cable comprising at least one conductor for defining a sense loop.
12. The security system of Claim 11, further comprising an alarm unit operably engaged with the cable and configured to generate a security signal when the sensor or the connector is removed from

the item of merchandise or the sense loop is interrupted.

13. The security system of Claim 11, further comprising a recoiler connected to the cable.

14. The security system of Claim 1, further comprising a power box configured to communicate with the item of merchandise to determine a voltage requirement of the item of merchandise via USB Power Delivery.

15. The security system of Claim 14, wherein the power box is configured to provide a voltage to the item of merchandise based on the voltage requirement.

16. The security system of Claim 14, wherein the power box is configured to convert an input AC voltage to an output DC voltage.

17. The security system of Claim 14, wherein the base is electrically connected to the power box.

18. The security system of Claim 17, wherein the power box is operably connected to the base via a USB-C connector.

19. The security system of Claim 1, wherein an end of the flexible circuit comprises one or more electrical contacts that are configured to align with and contact one or more electrical contacts on the sensor when the sensor is in engagement with the bracket for establishing an electrical connection.

20. The security system of Claim 1, further comprising a bracket assembly having at least one bracket arm configured to engage a side of the item of merchandise and the bracket, wherein the bracket assembly is configured to prevent removal of the sensor from the bracket.

21. The security system of Claim 1, wherein the flexible circuit is not soldered to the sensor.

22. A sensor assembly for securing an item of merchandise from theft or unauthorized removal, the sensor assembly comprising:

a bracket configured to be attached to an item of merchandise;

a sensor configured to releasably engage the bracket such that the sensor is removable from the bracket; and

a bracket assembly having at least one bracket arm configured to engage a side of the item of merchandise, wherein the bracket assembly is configured to prevent removal of the sensor from the bracket.

23. The sensor assembly of Claim 22, further comprising a flexible circuit with a connector configured to removably engage an input port of the item of merchandise and configured to be in electrical communication with the sensor, wherein the sensor is configured to detect unauthorized removal of the sensor or the connector from the item of merchandise.

24. A method for securing an item of merchandise from theft or unauthorized removal, the method comprising:

attaching a bracket to an item of merchandise;

engaging a sensor with the bracket; and

engaging a connector of a flexible circuit with an input port of the item of merchandise to establish electrical communication with the sensor, wherein the sensor is configured to detect unauthorized removal of the sensor or the connector from the item of merchandise.

25. The method of Claim 24, wherein attaching comprises attaching the bracket to a rear surface of the item of merchandise.

26. The method of Claim 24, further comprising engaging a bracket assembly with the item of merchandise and the bracket, wherein the bracket assembly is configured to prevent removal of the sensor from the bracket.

27. A security system for securing an item of merchandise from theft or unauthorized removal, the security system comprising:

a sensor configured to be electrically connected to the item of merchandise; and

a power box configured to communicate with the item of merchandise to determine a voltage requirement of the item of merchandise via USB Power Delivery,

wherein the power box is configured to provide a voltage to the item of merchandise based on the voltage requirement, and

wherein the sensor is configured to detect unauthorized removal of the item of merchandise from the sensor.

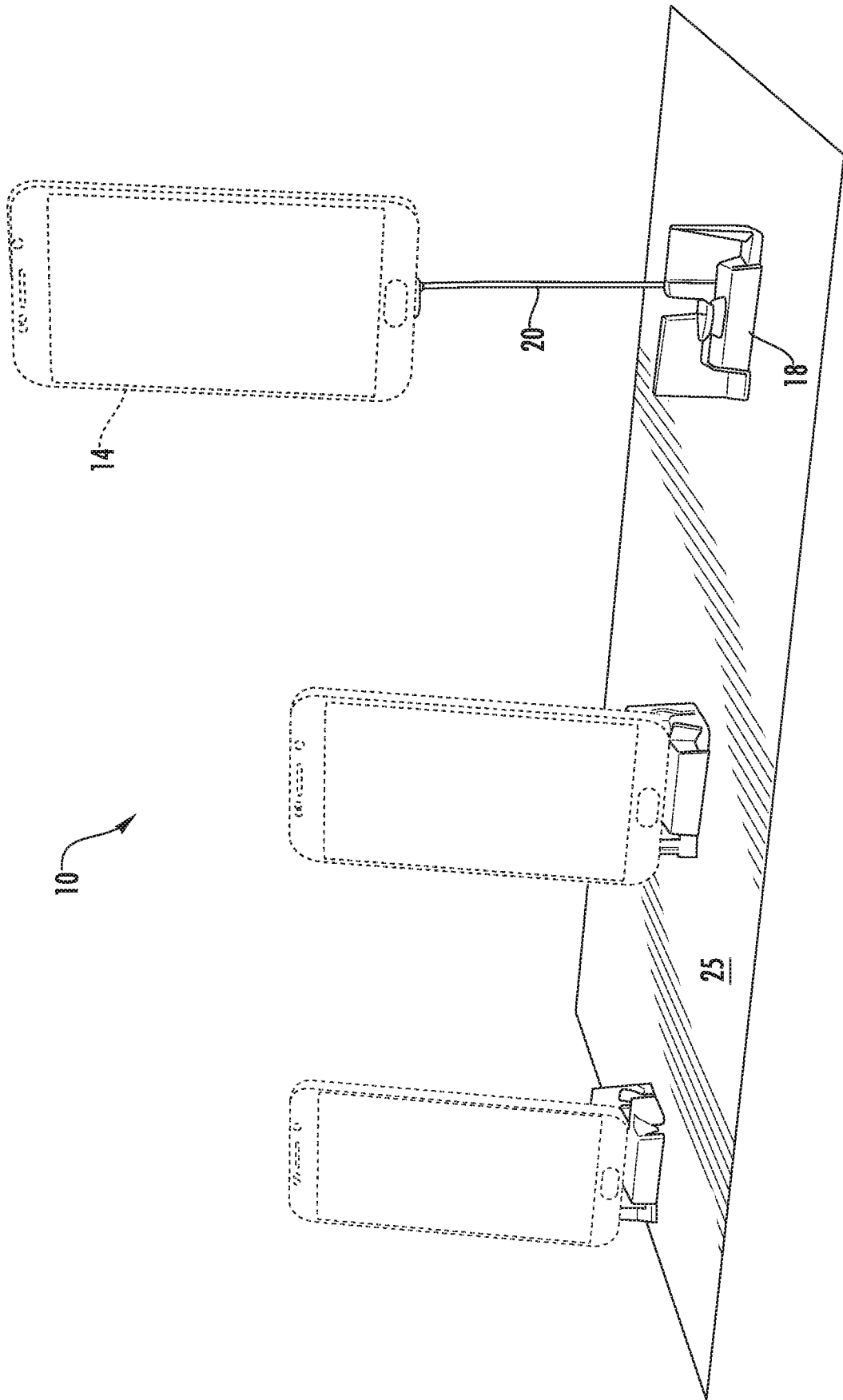

FIG. 1

2/22

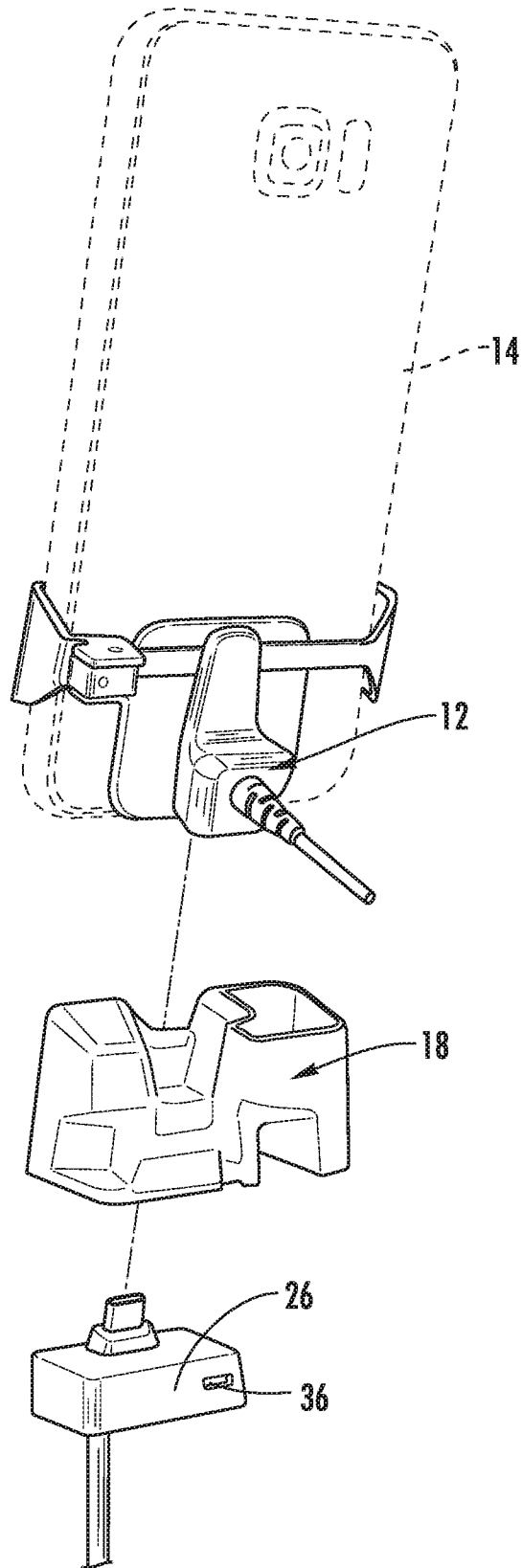

FIG. 2

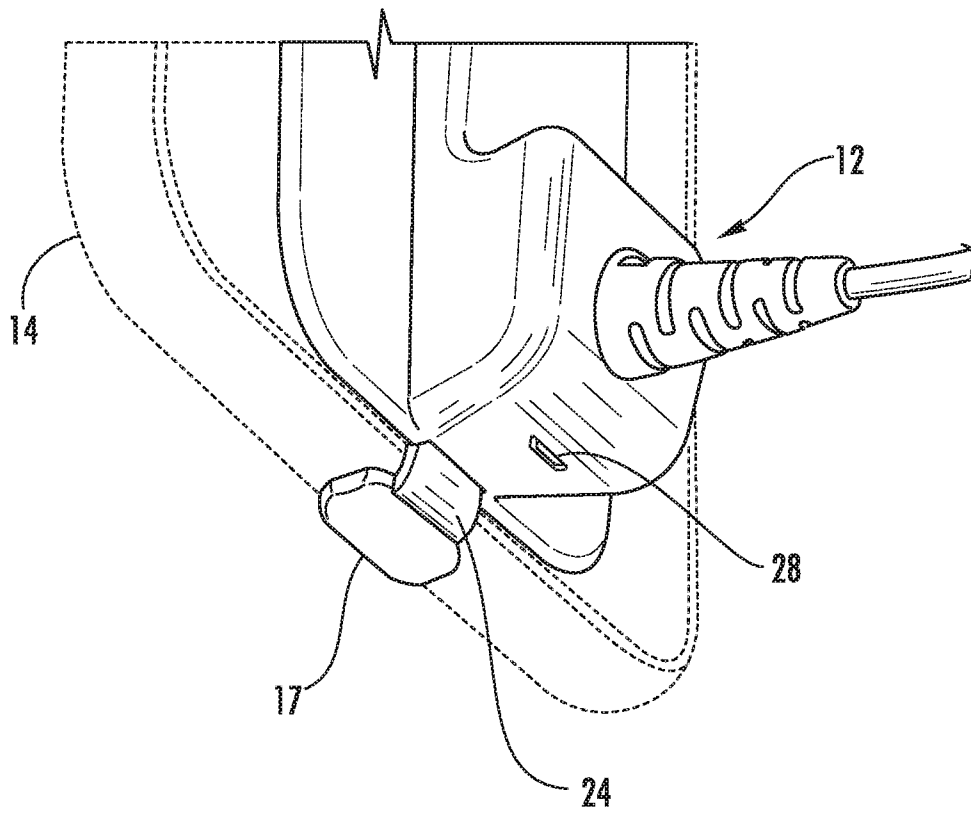

FIG. 3

4/22

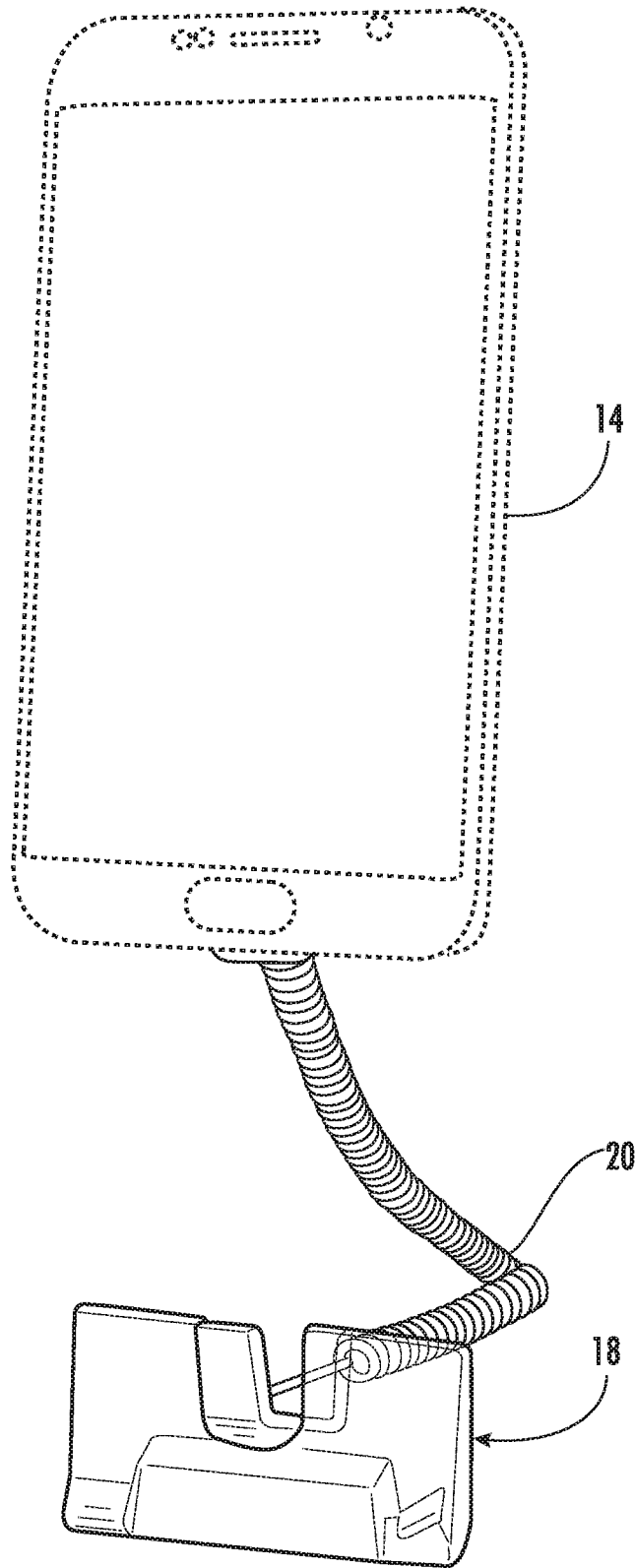

FIG. 4

5/22

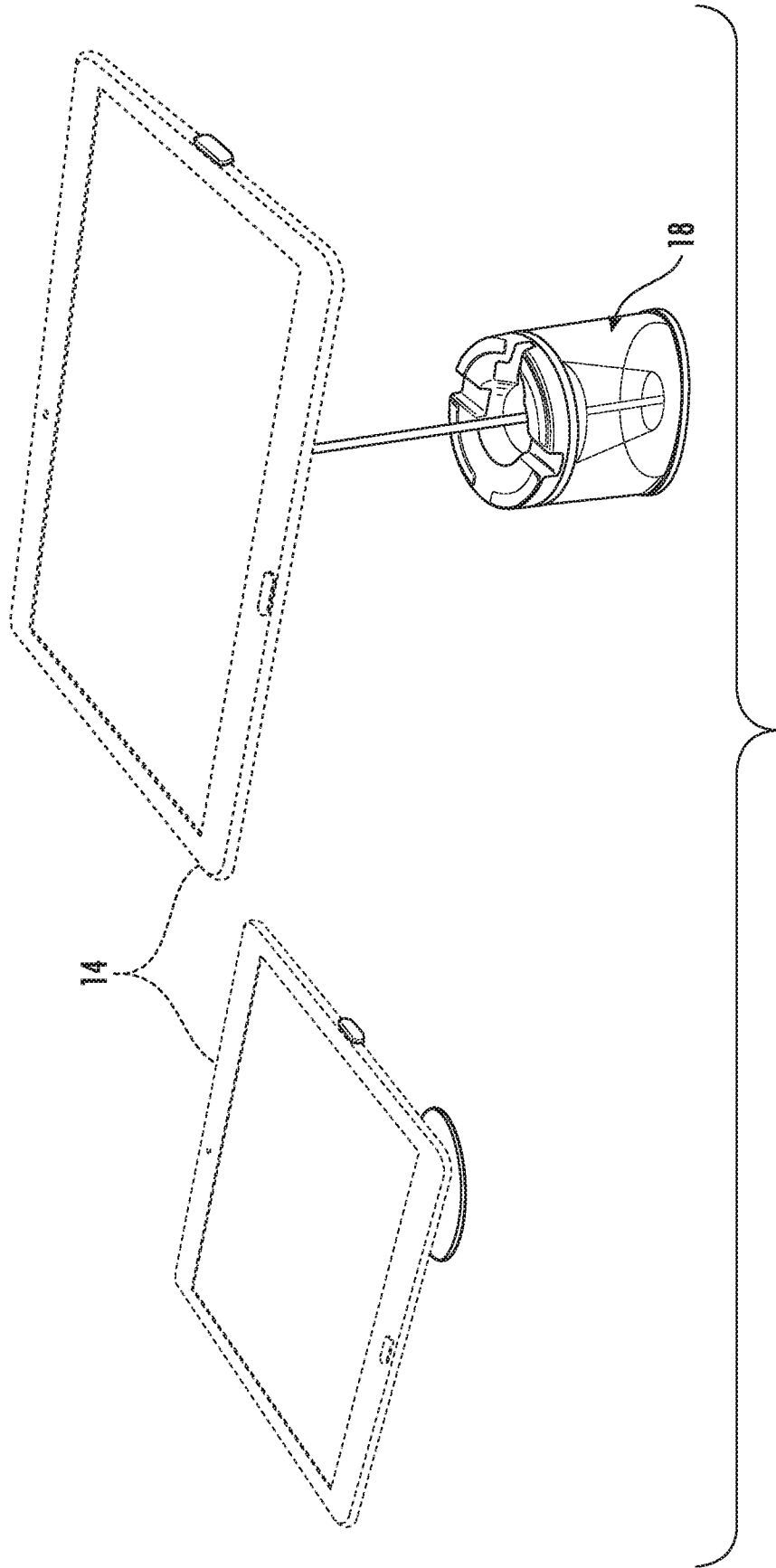

FIG. 5

6/22

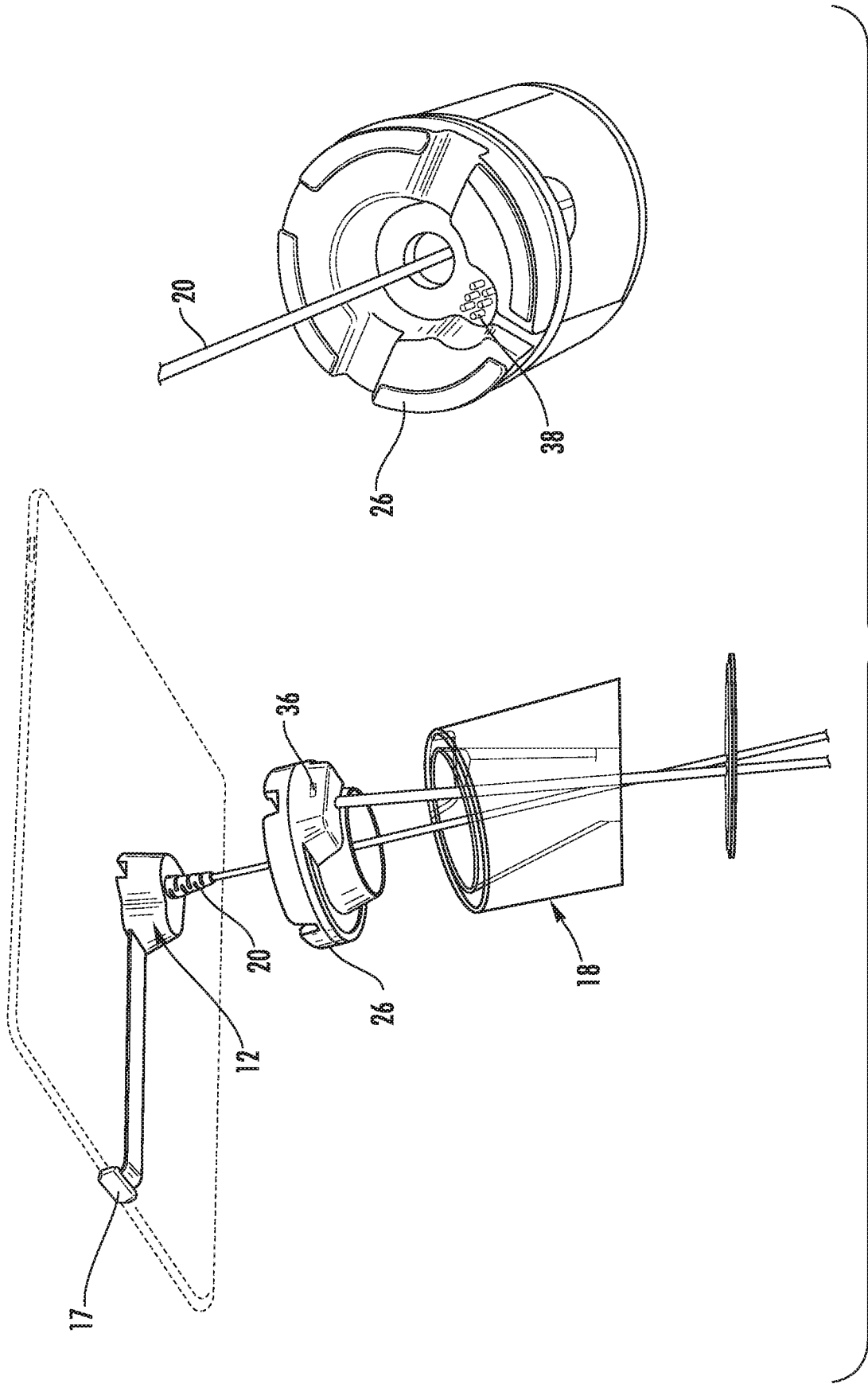

FIG. 6

7/22

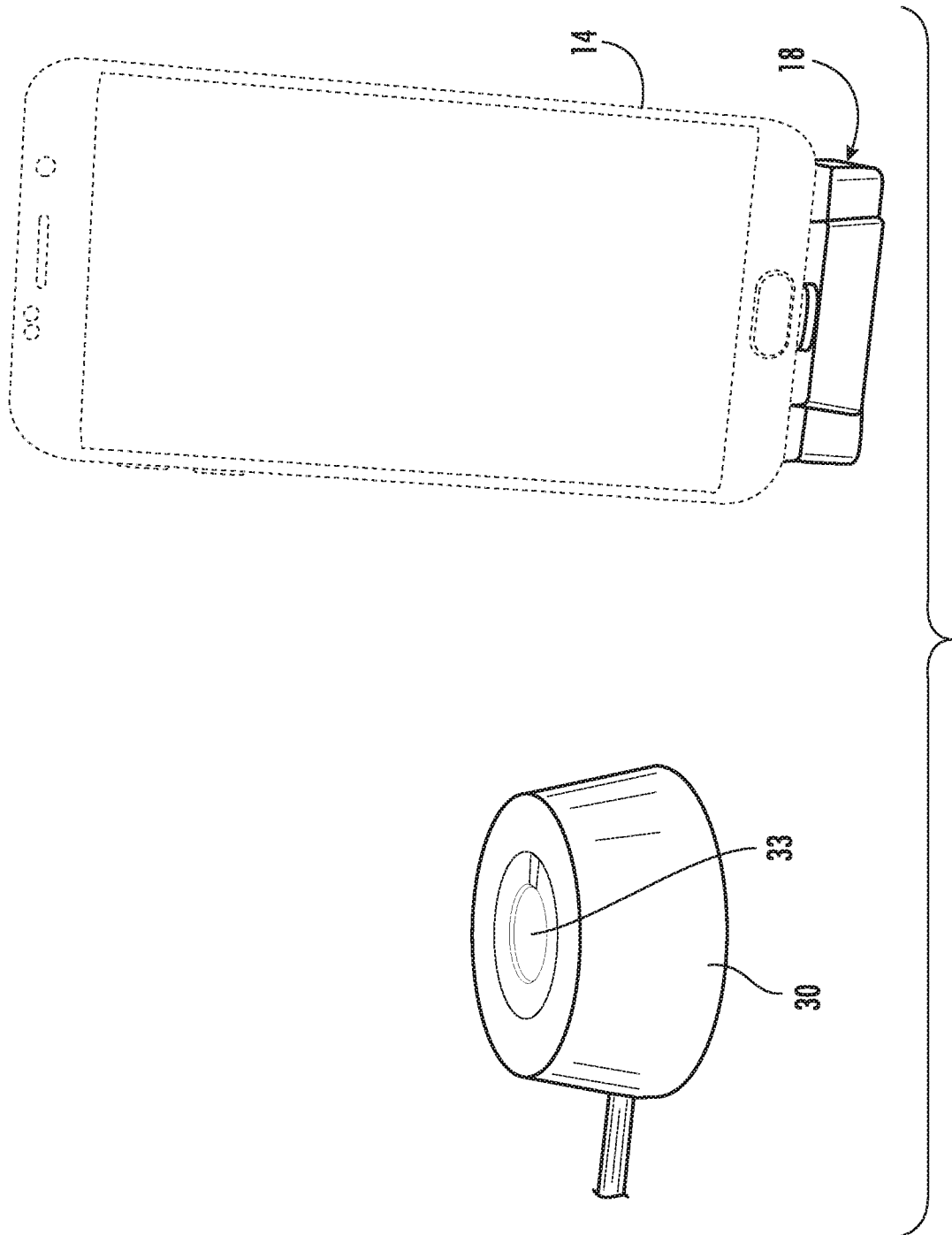

FIG. 7

9/22

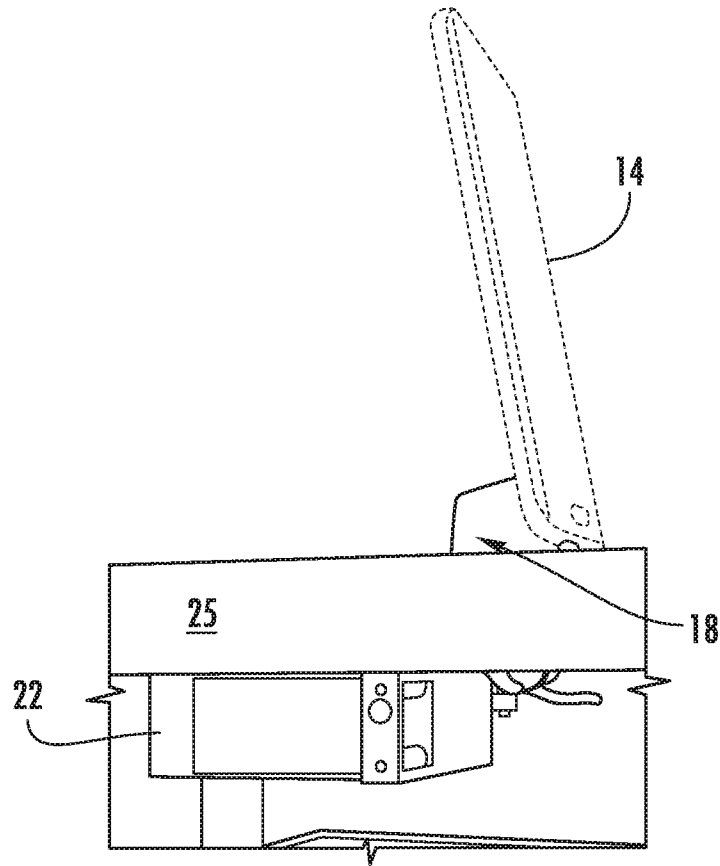

FIG. 10

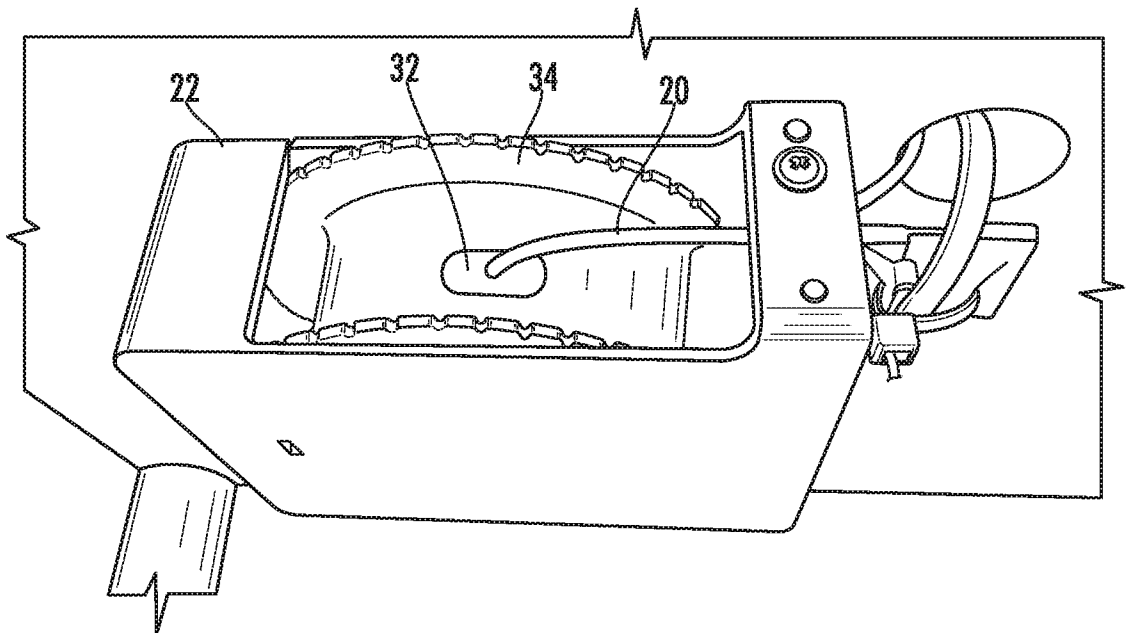

FIG. 11

10/22

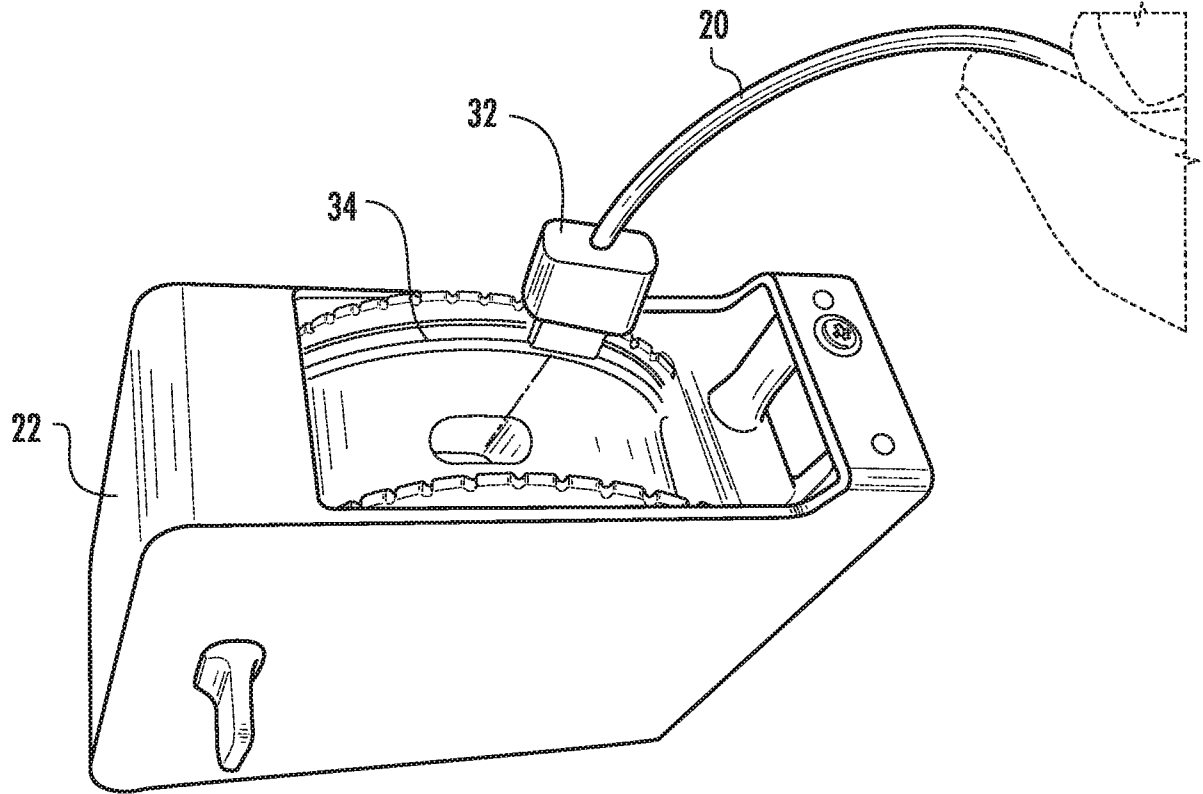

FIG. 12

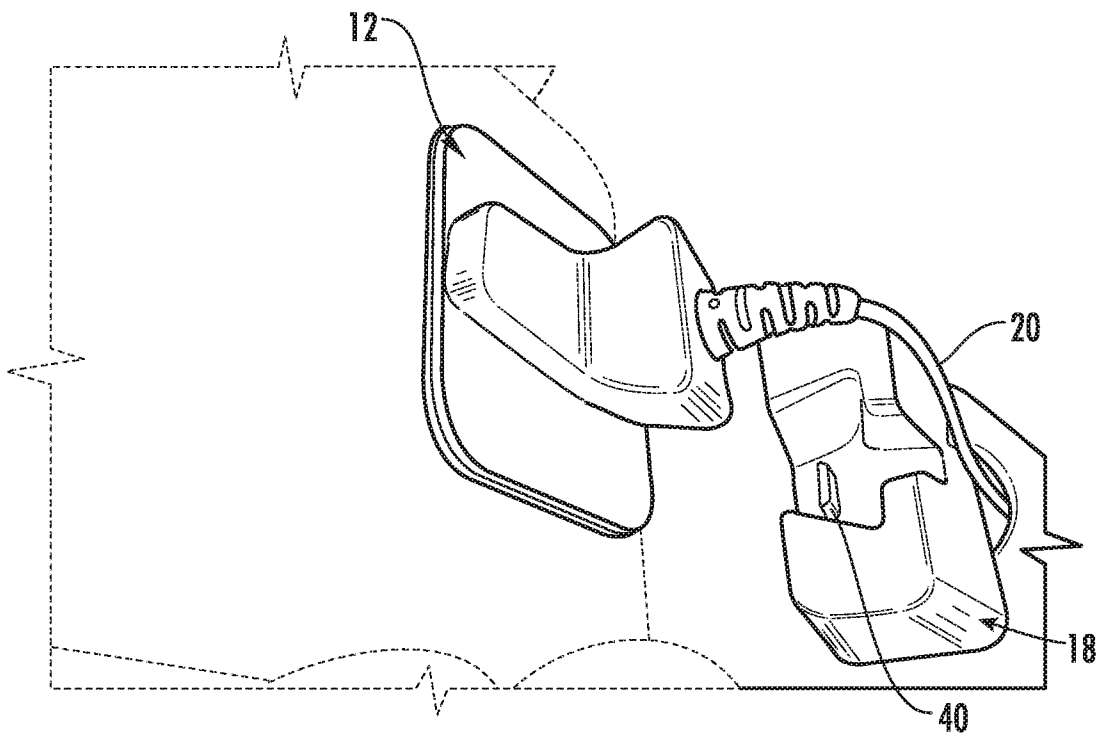

FIG. 13

11/22

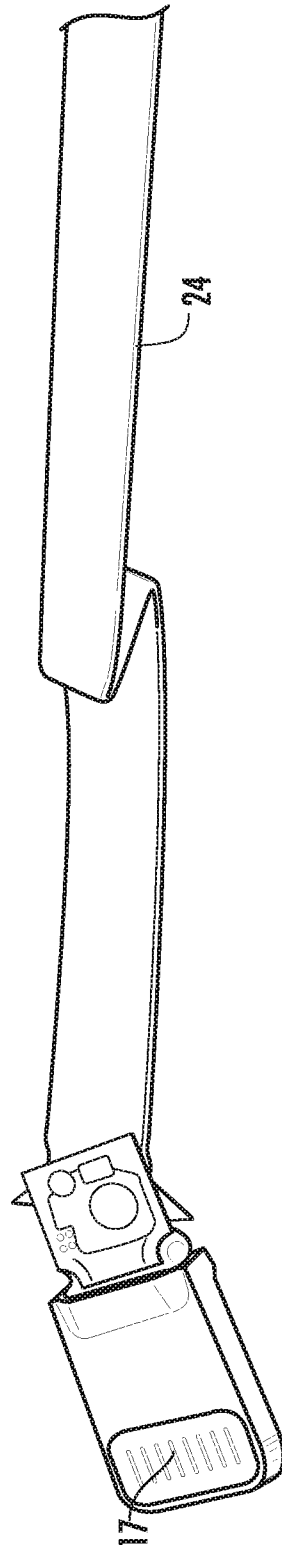

FIG. 14

12/22

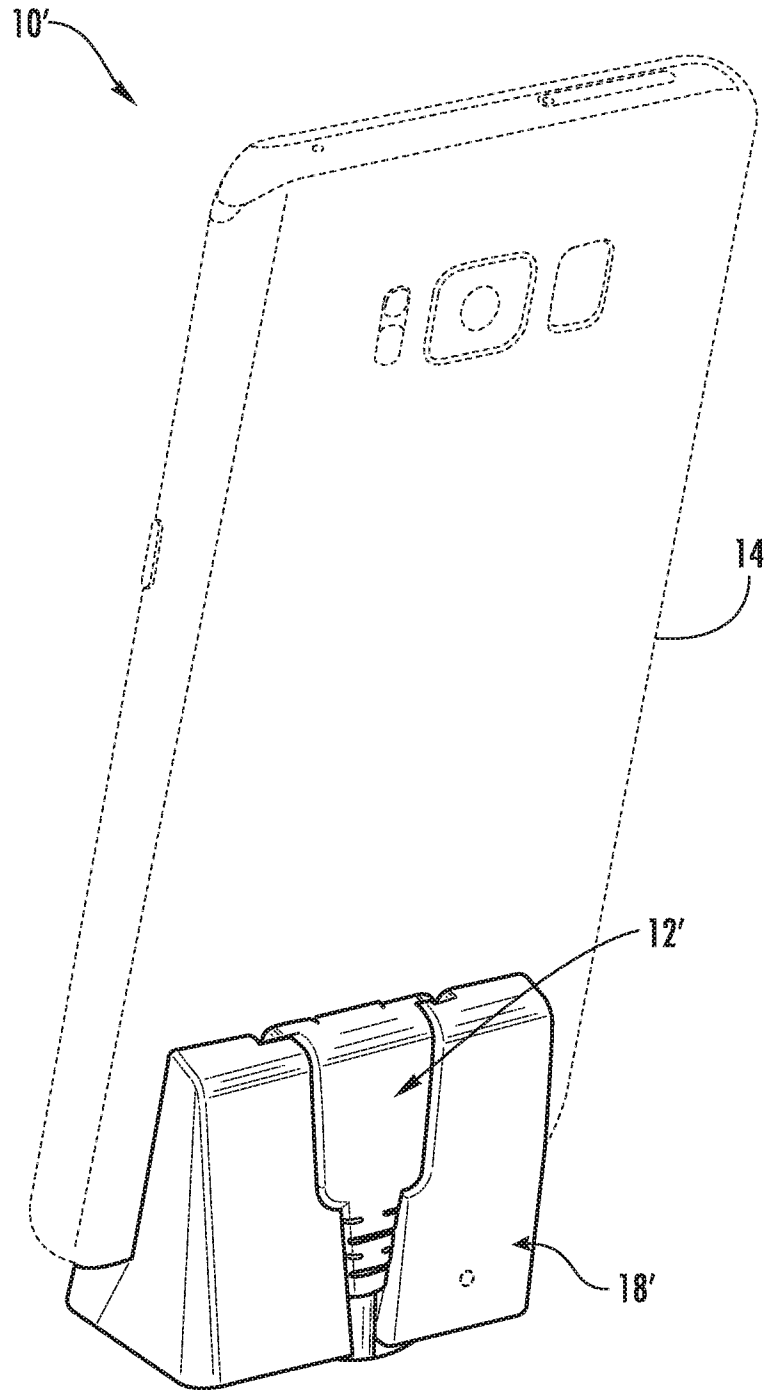

FIG. 15

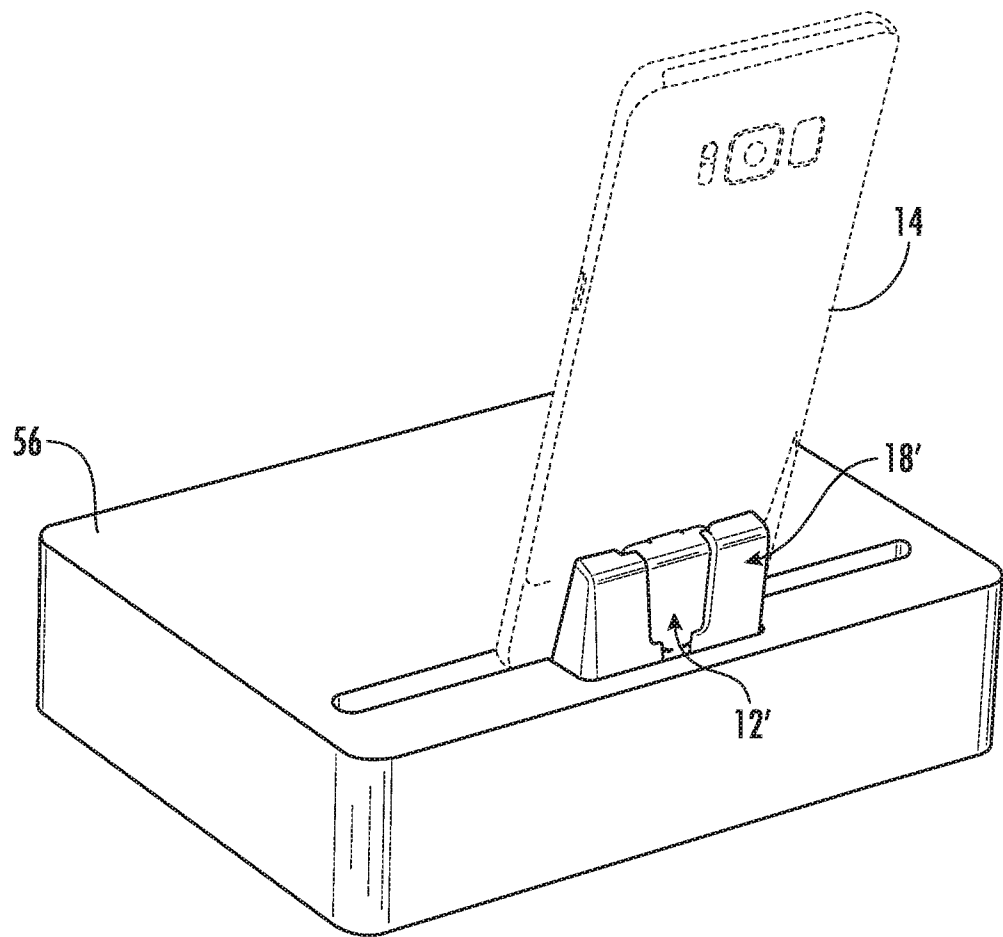

FIG. 16

14/22

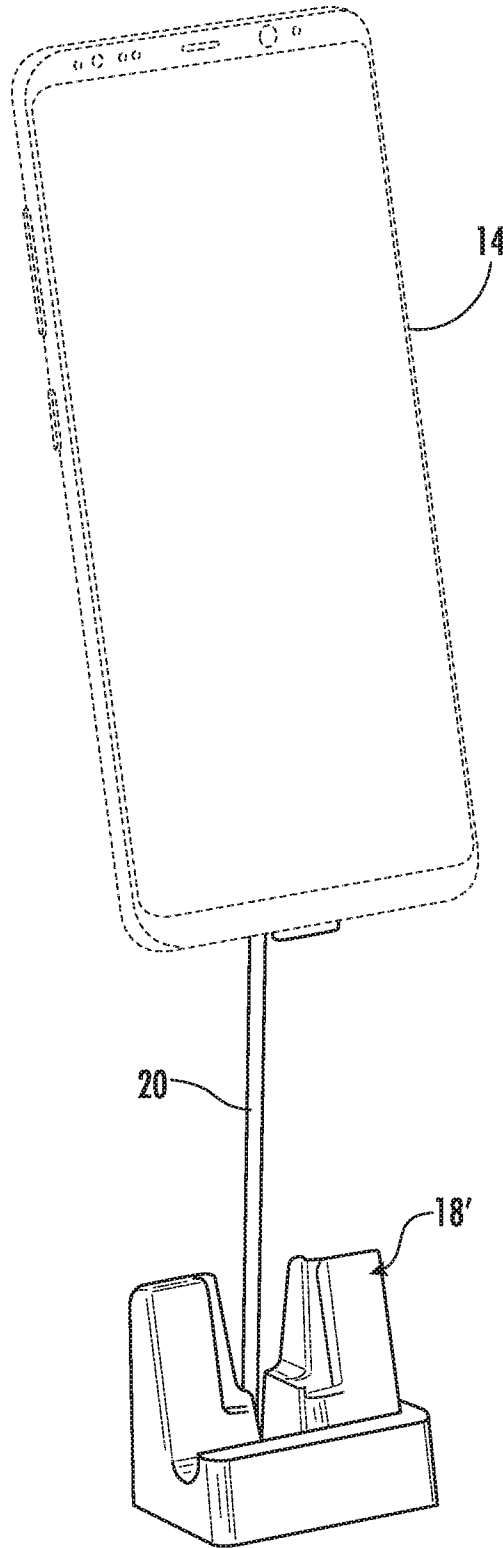

FIG. 17

15/22

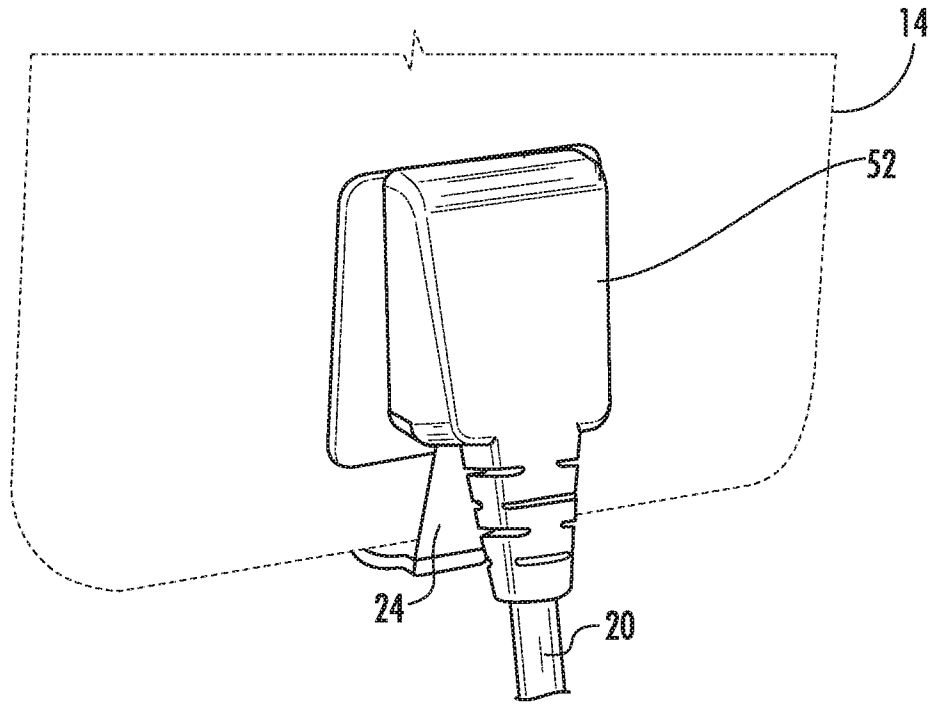

FIG. 18

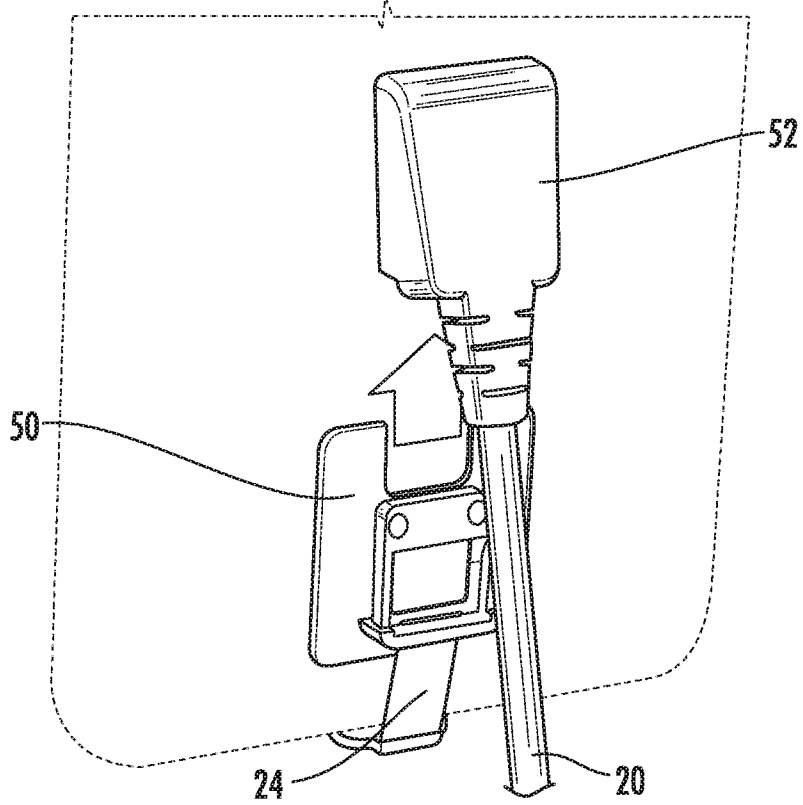

FIG. 19

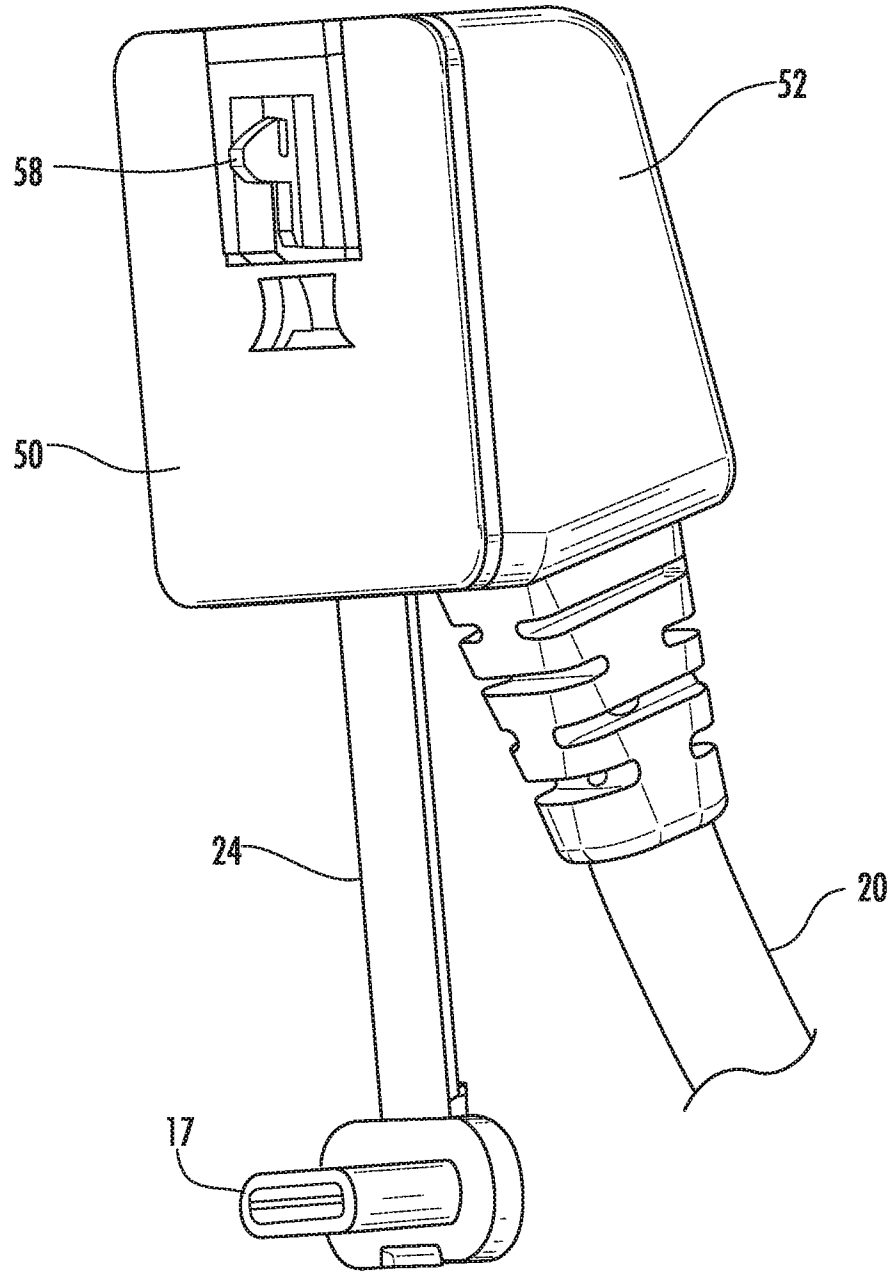

FIG. 20

17/22

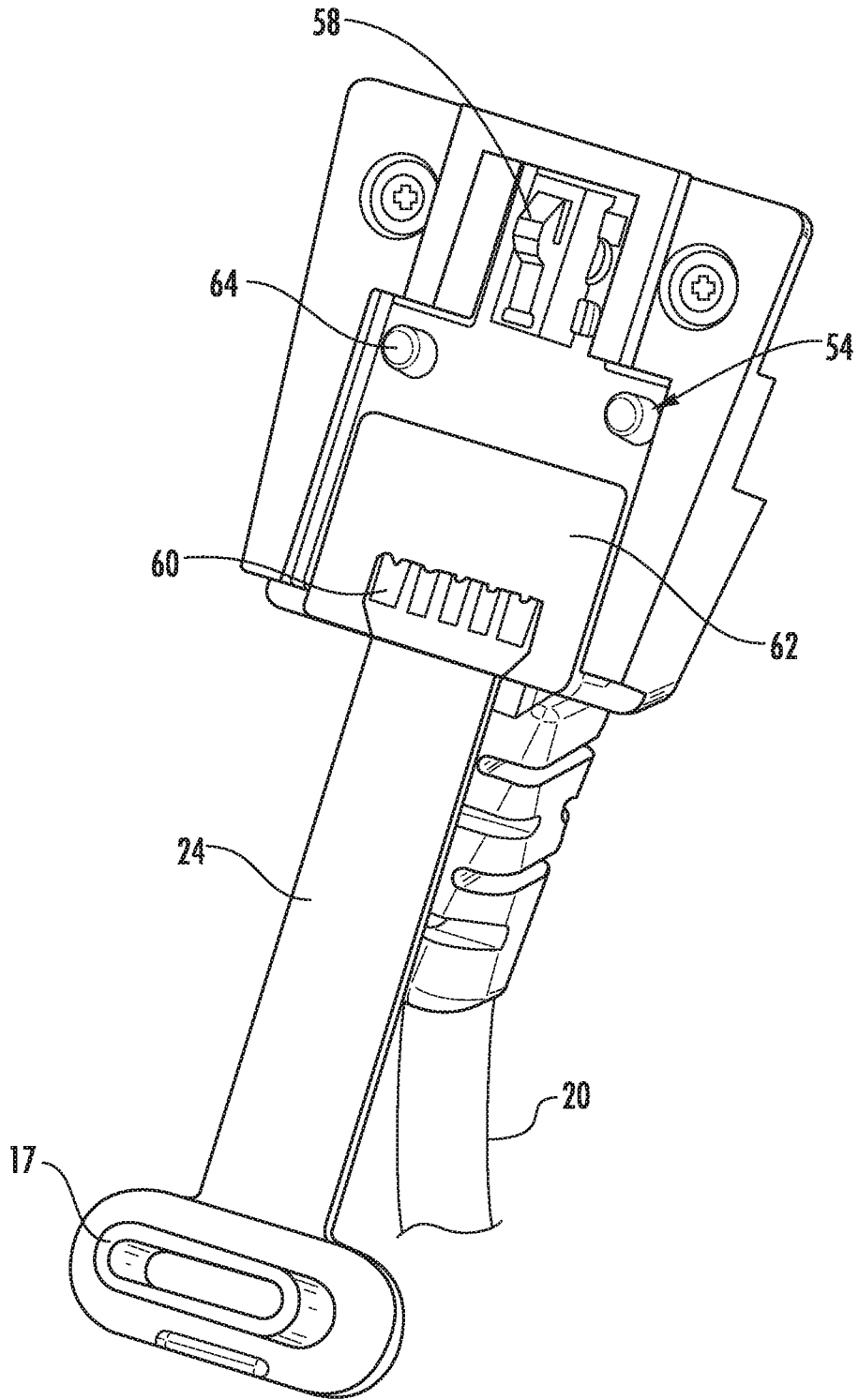

FIG. 21

18/22

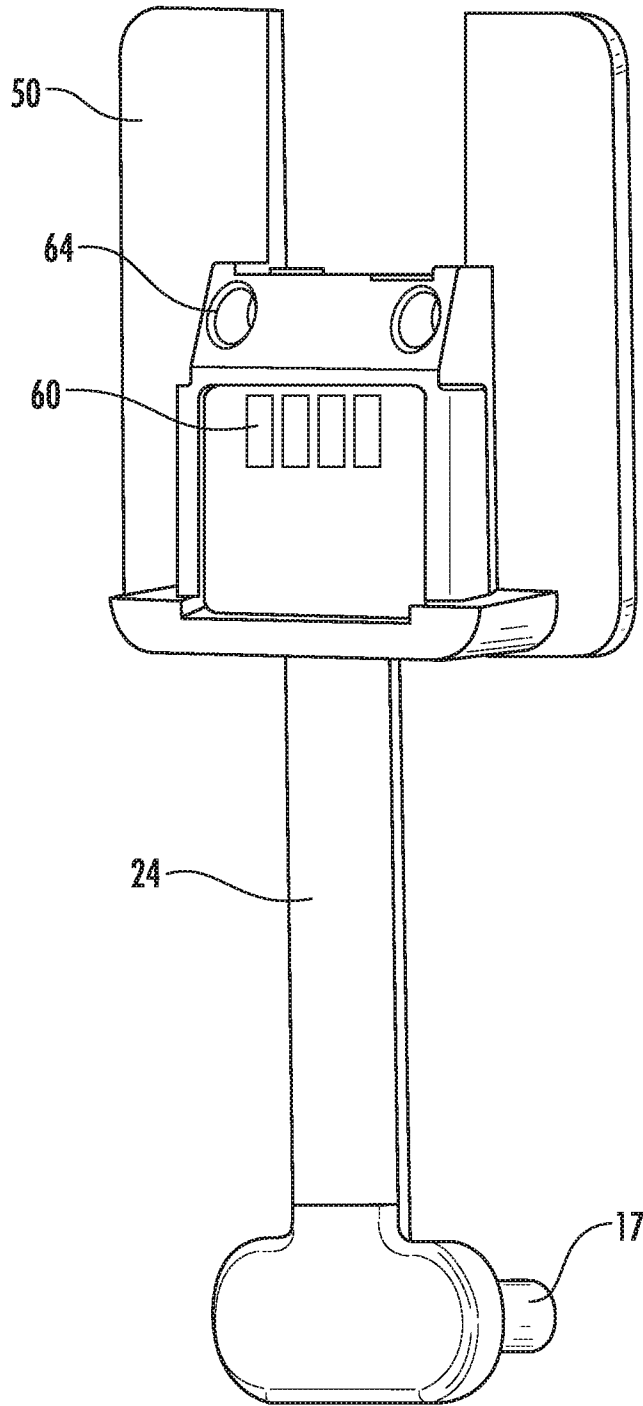

FIG. 22

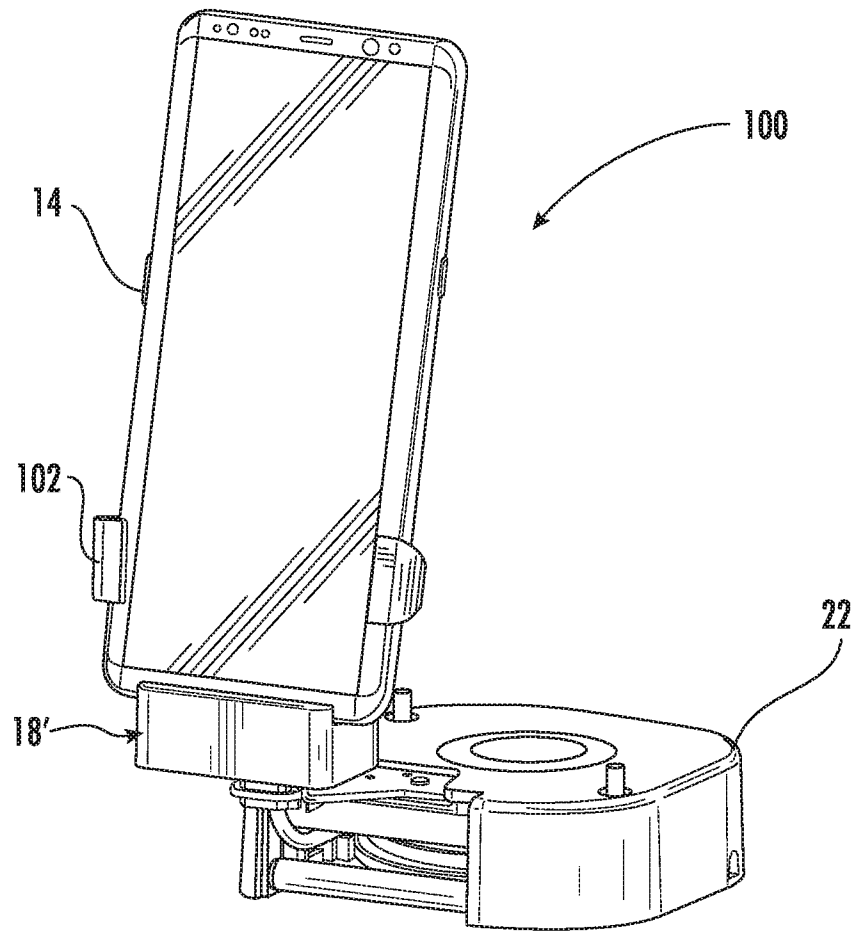

FIG. 23

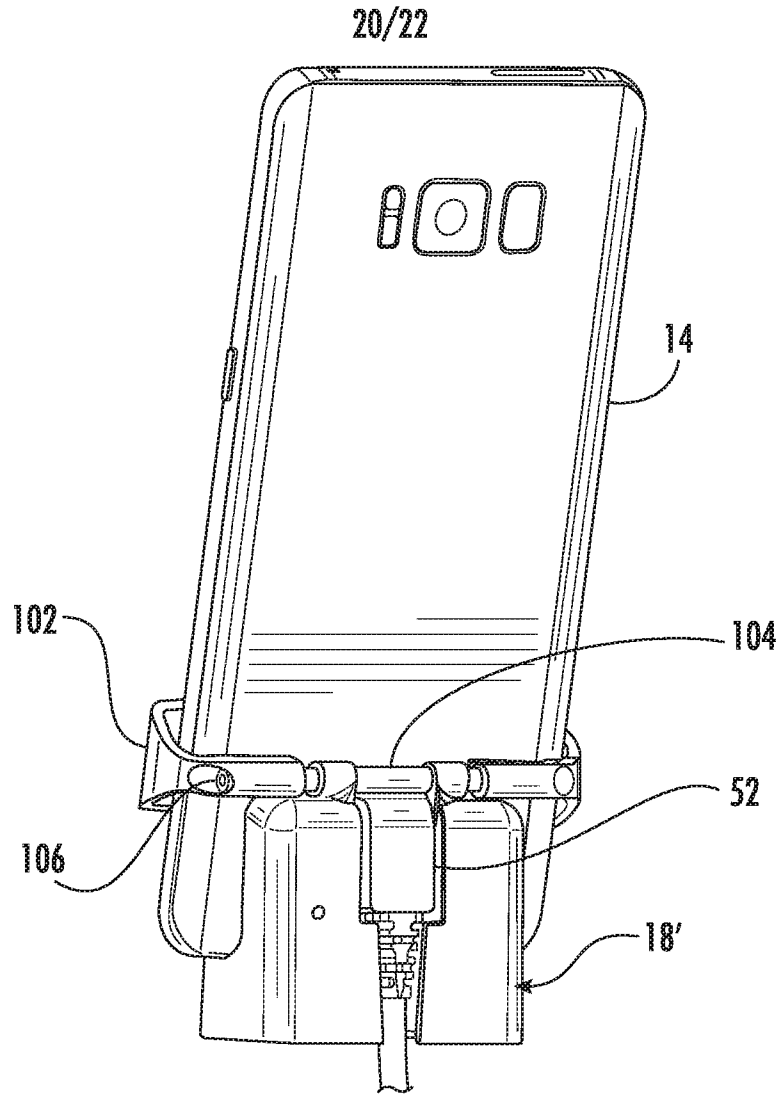

FIG. 24

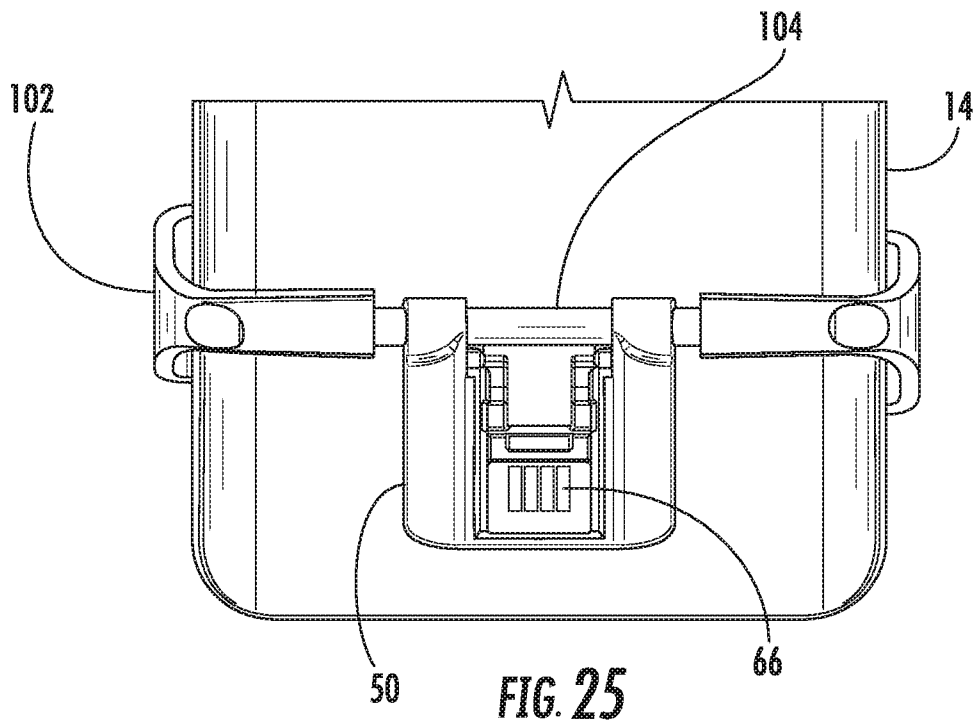

FIG. 25

21/22

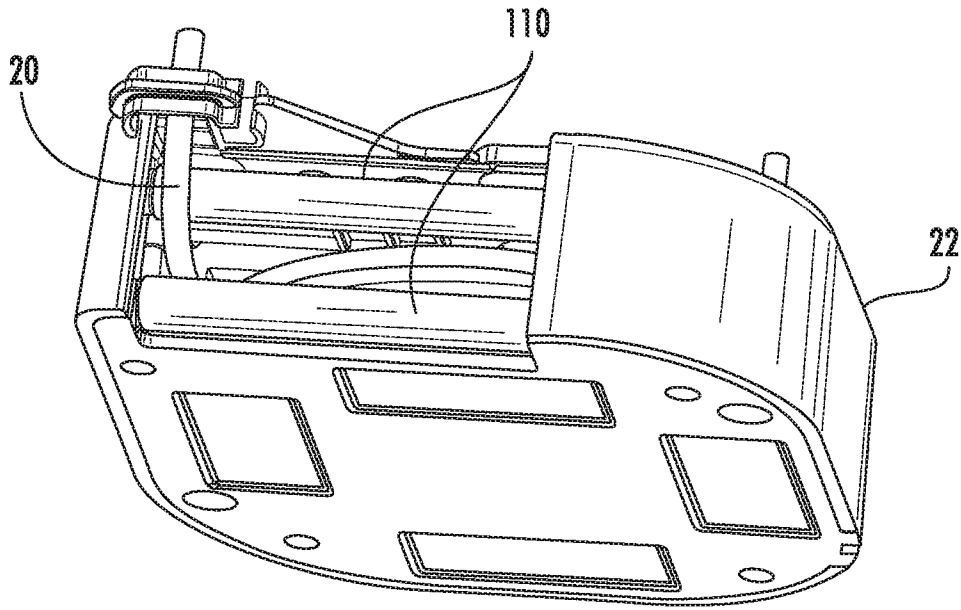

FIG. 26

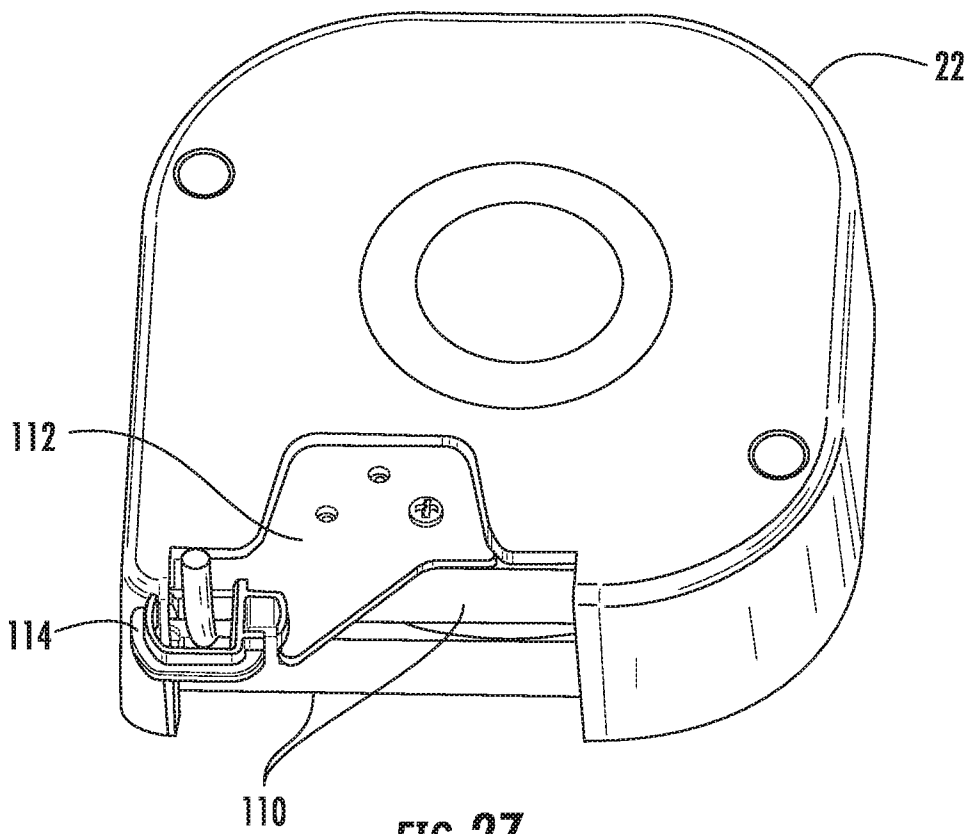

FIG. 27

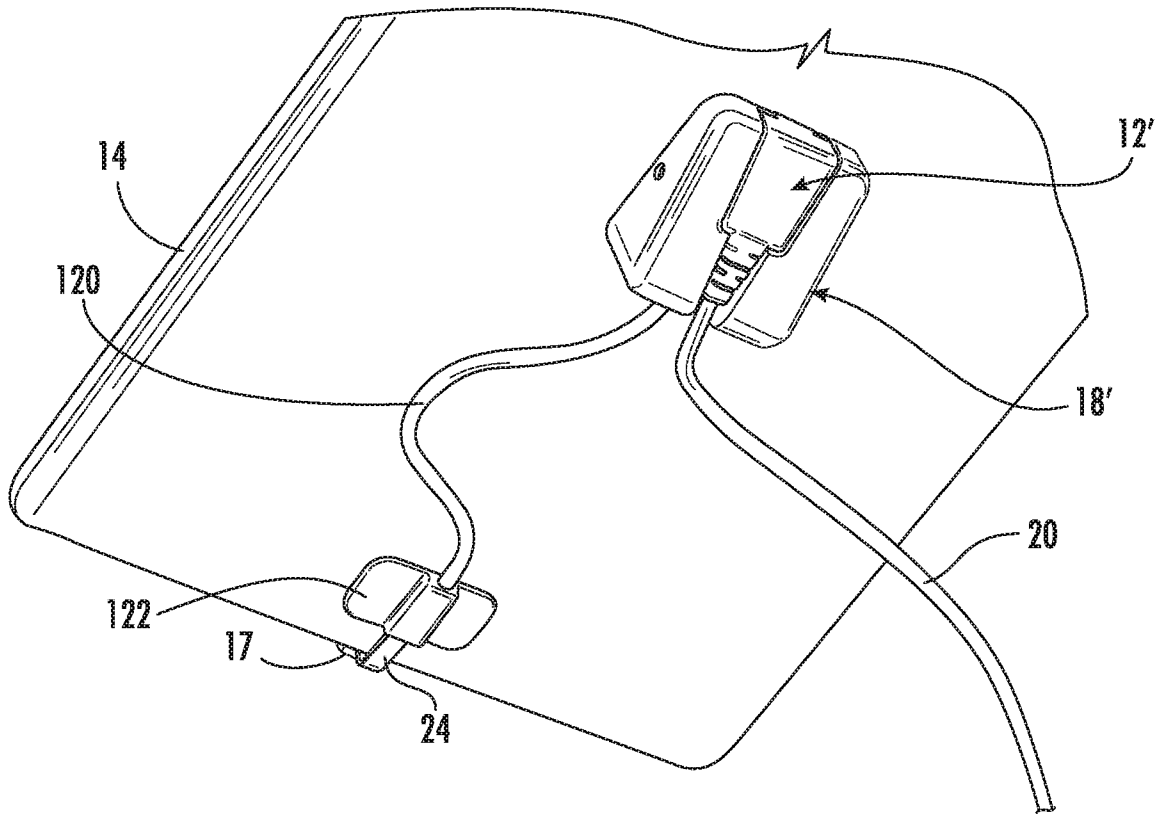

FIG. 28

INTERNATIONAL SEARCH REPORT

International application No.

PCT/US18/15000

A. CLASSIFICATION OF SUBJECT MATTER

IPC - G08B 13/14, 13/22; A47F 5/00, 5/08; E05B 47/00, 73/00 (2018.01)

CPC - G08B 13/1409, 13/1418, 13/1445, 13/1463; A47F 5/0861; E05B 47/0038, 73/0011, 73/0017, 73/0023, 73/0082

According to International Patent Classification (IPC) or to both national classification and IPC

B. FIELDS SEARCHED

Minimum documentation searched (classification system followed by classification symbols)

See Search History document

Documentation searched other than minimum documentation to the extent that such documents are included in the fields searched

See Search History document

Electronic data base consulted during the international search (name of data base and, where practicable, search terms used)

See Search History document

C. DOCUMENTS CONSIDERED TO BE RELEVANT

Category*	Citation of document, with indication, where appropriate, of the relevant passages	Relevant to claim No.
X ----- Y	WO 2016/014614 A1 (INVUE SECURITY PRODUCTS INC.) January 28, 2016; abstract; paragraphs [0025-0028, 0034-0037, 0042-0044]; figures 1, 5-8, 9	1-2, 4-12, 14-15, 19-21, 24-26 ----- 3, 13, 16-18
Y	US 2011/0100073 A1 (INVUE SECURITY PRODUCTS INC.) May 5, 2011; abstract; figure 6; paragraphs [0010, 0033]	3
Y	WO 2016/033037 A1 (INVUE SECURITY PRODUCTS INC.) March 3, 2016; paragraphs [0028-0029]; figures 3-4	13, 17, 18
Y	US 2004/0100807 A1 (MacDonald, G. et al.) May 27, 2004; abstract; figure 1; paragraphs [0020, 0023]	16
Y	Michael, C. USB 3.1 have you confused? Here's everything you need to know about the standard [online]. September 26, 2016 [retrieved on 2018-03-16]. Retrieved from Internet: <URL: https://www.digitaltrends.com/computing/what-is-usb-3-1-when-will-it-be-released-and-what-will-it-do-for-pcs/ >	18
A	US 2015/0300050 A1 (Gripzo B.V.) October 22, 2015; entire document	1-21, 24-26

 Further documents are listed in the continuation of Box C. See patent family annex.

* Special categories of cited documents:

"A" document defining the general state of the art which is not considered to be of particular relevance

"E" earlier application or patent but published on or after the international filing date

"L" document which may throw doubts on priority claim(s) or which is cited to establish the publication date of another citation or other special reason (as specified)

"O" document referring to an oral disclosure, use, exhibition or other means

"P" document published prior to the international filing date but later than the priority date claimed

"T" later document published after the international filing date or priority date and not in conflict with the application but cited to understand the principle or theory underlying the invention

"X" document of particular relevance; the claimed invention cannot be considered novel or cannot be considered to involve an inventive step when the document is taken alone

"Y" document of particular relevance; the claimed invention cannot be considered to involve an inventive step when the document is combined with one or more other such documents, such combination being obvious to a person skilled in the art

"&" document member of the same patent family

Date of the actual completion of the international search

16 March 2018 (16.03.2018)

Date of mailing of the international search report

10 MAY 2018

Name and mailing address of the ISA/

Mail Stop PCT, Attn: ISA/US, Commissioner for Patents
P.O. Box 1450, Alexandria, Virginia 22313-1450
Facsimile No. 571-273-8300

Authorized officer

Shane Thomas

PCT Helpdesk: 571-272-4300
PCT OSP: 571-272-7774

INTERNATIONAL SEARCH REPORT

International application No.

PCT/US18/15000

Box No. II Observations where certain claims were found unsearchable (Continuation of item 2 of first sheet)

This international search report has not been established in respect of certain claims under Article 17(2)(a) for the following reasons:

1. Claims Nos.:
because they relate to subject matter not required to be searched by this Authority, namely:

2. Claims Nos.:
because they relate to parts of the international application that do not comply with the prescribed requirements to such an extent that no meaningful international search can be carried out, specifically:

3. Claims Nos.:
because they are dependent claims and are not drafted in accordance with the second and third sentences of Rule 6.4(a).

Box No. III Observations where unity of invention is lacking (Continuation of item 3 of first sheet)

This International Searching Authority found multiple inventions in this international application, as follows:
See extra sheet.

1. As all required additional search fees were timely paid by the applicant, this international search report covers all searchable claims.
2. As all searchable claims could be searched without effort justifying additional fees, this Authority did not invite payment of additional fees.
3. As only some of the required additional search fees were timely paid by the applicant, this international search report covers only those claims for which fees were paid, specifically claims Nos.:

4. No required additional search fees were timely paid by the applicant. Consequently, this international search report is restricted to the invention first mentioned in the claims; it is covered by claims Nos.:
1-21, 24-26

- Remark on Protest**
- The additional search fees were accompanied by the applicant's protest and, where applicable, the payment of a protest fee.
 - The additional search fees were accompanied by the applicant's protest but the applicable protest fee was not paid within the time limit specified in the invitation.
 - No protest accompanied the payment of additional search fees.

INTERNATIONAL SEARCH REPORT
Information on patent family members

International application No.

PCT/US18/15000

-Continued from Box III-

This application contains the following inventions or groups of inventions which are not so linked as to form a single general inventive concept under PCT Rule 13.1. In order for all inventions to be examined, the appropriate additional examination fee must be paid.

Group I: Claims 1-21, 24-26 are directed towards a security system for securing an item of merchandise from theft or unauthorized removal comprising a flexible circuit with a connector configured to removably engage an input port of the item of merchandise.

Group II: Claims 22-23 are directed towards a sensor assembly for securing an item of merchandise from theft or unauthorized removal.

Group III: Claim 27 are directed towards a security system for securing an item of merchandise from theft or unauthorized removal comprising: a power box configured to communicate with the item of merchandise to determine a voltage requirement of the item of merchandise via USB Power Delivery.

The inventions listed as Groups I-II do not relate to a single inventive concept under PCT Rule 13.1 because, under PCT Rule 13.2, they lack the same or corresponding special technical features.

Group I has at least a flexible circuit with a connector configured to removably engage an input port of the item of merchandise and configured to be in electrical communication with the sensor, that Groups II and III do not have.

Group II has at least a bracket assembly having at least one bracket arm configured to engage a side of the item of merchandise, wherein the bracket assembly is configured to prevent removal of the sensor from the bracket, that Groups I and III do not have.

Group III has at least a power box configured to communicate with the item of merchandise to determine a voltage requirement of the item of merchandise via USB Power Delivery, wherein the power box is configured to provide a voltage to the item of merchandise based on the voltage requirement, that Groups I and II do not have.

The common technical features of Groups I-III are a security system for securing an item of merchandise from theft or unauthorized removal; the security system comprising: a bracket configured to be attached to an item of merchandise; a sensor configured to releasably engage the bracket; wherein the sensor is configured to detect unauthorized removal of the sensor or the connector from the item of merchandise.

The common technical features are disclosed by WO 2016/014614 A1 to INVUE SECURITY PRODUCTS INC. (hereinafter "INVUE"). INVUE discloses a security system for securing an item of merchandise from theft or unauthorized removal (a security system 10 for securing an item or merchandise 14 from theft or unauthorized removal; abstract; paragraphs [0025-0026]; figure 1), the security system comprising: a bracket configured to be attached to an item of merchandise (security system 10 includes a clip 20 (bracket) to attach to the item of merchandise 14; paragraphs [0027-0028]; figure 1); a sensor configured to releasably engage the bracket (sensor 12 is removably engaged with the clip 20; paragraphs [0027-0028]; figure 1); wherein the sensor is configured to detect unauthorized removal of the sensor or the connector from the item of merchandise (sensor 12 detects unauthorized removal of the sensor 12 or the connector 16 from the item of merchandise 14; paragraphs [0034, 0037]; figure 1).

Since the common technical feature is previously disclosed by the INVUE reference, these common features are not special and so Groups I-III lack unity.