

(19) **DANMARK**

(10) **DK/EP 2385596 T3**



Patent- og  
Varemærkestyrelsen

(12) **Oversættelse af  
europæisk patentskrift**

- 
- (51) Int.Cl.: **H 02 G 3/08 (2006.01)**      **B 60 L 53/14 (2019.01)**      **B 60 L 53/30 (2019.01)**  
**B 60 L 53/31 (2019.01)**      **H 02 B 1/50 (2006.01)**      **H 02 G 3/04 (2006.01)**
- (45) Oversættelsen bekendtgjort den: **2020-02-24**
- (80) Dato for Den Europæiske Patentmyndigheds bekendtgørelse om meddelelse af patentet: **2019-11-20**
- (86) Europæisk ansøgning nr.: **11003312.3**
- (86) Europæisk indleveringsdag: **2011-04-20**
- (87) Den europæiske ansøgnings publiceringsdag: **2011-11-09**
- (30) Prioritet: **2010-05-03 DE 102010019143**
- (84) Designerede stater: **AL AT BE BG CH CY CZ DE DK EE ES FI FR GB GR HR HU IE IS IT LI LT LU LV MC MK MT NL NO PL PT RO RS SE SI SK SM TR**
- (73) Patenthaver: **chargelT mobility GmbH, Steigweg 24, 97318 Kitzingen, Tyskland**
- (72) Opfinder: **Xiong, Ge, Schönfelder Strasse 57 DG, 34121 Kassel, Tyskland**  
**Beck, Bernhard, Gerlachshausener Str. 1, 97332 Volkach, Tyskland**  
**Bachmann, Sebastian, Kötzlerstrasse 11, 90453 Nürnberg, Tyskland**
- (74) Fuldmægtig i Danmark: **Chas. Hude A/S, H.C. Andersens Boulevard 33, 1780 København V, Danmark**
- (54) Benævnelse: **Apparat med et rør og med et herpå monterbart hus til en strømopladningsboks til elektrokøretøjer**
- (56) Fremdragne publikationer:  
**EP-A1- 2 028 580**  
**EP-A2- 1 335 462**  
**DE-U- 6 934 971**  
**DE-U1- 8 424 199**  
**US-A- 3 753 047**



## Description

The invention relates to an apparatus having a tube and having a housing, which can be mounted thereon, having three side walls, a bottom and a  
5 cover, wherein in a first side wall an opening for introducing a tube is formed.

Housings and their embodiments are very well known, wherein depending on application case either the design, in the case of mass-produced articles in particular the costs and functionality, such as for example accessibility to the  
10 interior, the interchangeability etc. play a role.

From EP 2 028 580 A1 an operating desk for a machine tool having a housing that is pivotably arranged on a support arm is known. The housing has an upper and a lower housing shell which are formed so as to be pivotable and  
15 lockable relative to one another. From the documents EP 1335 462 A2, DE 842 4199 U1, US 3753047 and DE 69 3497 1U, further arrangements having a tube and a housing that can be mounted thereon are known.

Since in a charge box for electric vehicles more or less all of these aspects  
20 have to be taken into account, the invention set itself the task to state an apparatus having a housing with attractive design, which can be easily interchanged against another housing of identical construction yet allows a cost-effective production with few parts.

25 According to the invention, this object is solved through the subject of Claim 1.

This procedure offers the advantage that, following the unlocking of the lock, the housing can be simply extracted from the guide together with the tube piece and is freely available for further use such as for example maintenance, repair or replacement. On the side wall located opposite the first side wall,  
5 aligned with the opening, a first part of an electrical plug connector is fastened and the tube, at its free end, comprises the counterpart to the first part of the plug connector and has an adequate length in order to, when introduced through the opening, establish the plug connection between the two parts of the plug connector. By way of this measure, the plug connection is dis-  
10 connected simultaneously with the pulling-off of the housing from the tube. However it is also possible to employ a classic plug connector with connector and socket, to which an electrical supply line each is wired. The same is then loosely pushed into the tube and, with suitable length of the supply lines, does not obstruct an unhindered removal of the housing from the tube.

15

The housing skin is further simplified when the fourth side wall is formed through a bent part of the outer housing or through a part of the lateral surface of the tube. The housing skin then consists of two parts: i) the U-part with the three side surfaces and ii) of the outer part with the integrated fourth  
20 lateral surface. The outer housing is preferentially produced from a polycarbonate and the U-part from a rust-protected or non-rusting material. The three side walls forming the U can be a one-piece sheet metal part which is rounded off at its corners or edges. Besides the roundings, a distinctive design is obtained when the opening is located in the upper third or fourth of  
25 the first side wall. Then, a desk-like appearance of the electric charging point materializes which ensures a high recognition value.

The use of the housing as electric charge box is further simplified when the tube is substantially angled at a right angle so that two tube portions of unequal length are formed, of which the short tube piece is guided through the opening and the long tube piece with its end fastened to the ground. The  
5 long tube portion is then approximately 150 cm long and the short tube piece approximately 45 cm. In order to achieve a fixed inclination of the housing cover relative to the ground surface, the short tube portion on its lateral surface has an elongate convexity running parallel to the central axis of the tube, which is matched in a form-fitting manner to a cutout on the periphery of the  
10 opening. Thus, twisting is excluded since by way of the combination of cutout with the convexity a type of hook is provided which intercepts a torque.

This hook can be expanded into a guide rail when the cutout constitutes the groove start of a groove which is formed by means of a profile strip adjacent  
15 to the cutout, which runs as far as to the opposite side wall where it is connected to the same.

The intended function of the housing requires that on at least one side wall at least one first part of a further plug connector is attached. The housing is  
20 preferentially fitted on the side surfaces (wherein in principle however the bottom or the cover are also possible) with the sockets or the connectors of two further plug connectors or four further plug connectors. The further plug connectors 25 initially consist of parts of conventional 230 volt plug connections or power current sockets or connectors and, the further cutouts, are  
25 mounted on the housing freely accessible from the outside.

Further configurations and advantages of the invention are obtained from the description of an exemplary embodiment by way of the figures. There:

30 Fig. 1 shows a view of the assembly of a housing according to the invention;

Fig. 2 shows a housing as alternative wall assembly;

Fig. 3 shows a detail view regarding the guardrail; and

Fig. 4 shows a detail view regarding the locking.

5 In Figure 1, a U-shaped first housing part is shown with 1, which comprises two limb sides 3, 5 and a bottom side 7. In one of its limb sides 3, a circular opening 9 is provided. The diameter of the opening 9 is matched to the outer diameter of a tube 19, so that the tube 19 can be introduced into the interior of the U from the outside.

10

At its end, the tube 19 is provided with a connecting socket 17 which is embodied so that it forms the counterpart to the connector 15 in the tube 11. The tube 11 is located on the limb side 5. In order to ensure the correct position and orientation of the connecting socket 17 and of the connector 15,  
15 a groove rail 21 is provided in the housing 1 and on the tube 19 a guide rail 23. Thus, the housing 1 can be mounted and demounted along the arrow 13.

On the short tube portion 19a, a convexity in the form of a rail 23 is addition-  
20 ally shown, which extends in the direction of the longitudinal axis of the tube portion 11. The dimensions, i.e. the width and the height of the rail 21 are matched to the dimensions of a cutout 31 (not shown), which, emanating from the periphery of the opening 9, extends into the side wall 3. The cutout 31 (not shown) together with the rail 21 brings about an anti-rotation protec-  
25 tion between the tube piece 11 and the U-shaped part 1. The cutout 31 is followed by a profile strip or profile rail 21, which forms a groove or a channel 35 (not shown) in which the rail 23 can slide. The profile rail 21 is firmly connected to the two limbs 3, 5 of the U-part 1 and thus serve simultaneously as a reinforcement. The profile rail 21, the pipe section 11 and the cutout 31  
30 are once more shown in Figure 3 in enlarged representation.

Furthermore, a component box 29 is provided in the housing 1, so that the electrical components are protected from the effects of the weather. The connectors 25 are connected to this box and fastened to one of the limb sides 3, 5 or cover 6.

5

From Figure 2, an alternative wall assembly method is shown. It shows a pipe section 19c, which is fastened to the wall 43 by means of an assembly plate 41. Furthermore, the cover 6 with integrated monitor 39 is shown in Figure 2.

10

In Figure 3, a detail view of the groove rail 21 is visible. Here, the cutout 31 is clearly visible which merges into a groove or a channel 35 of the rail 21 in order to ensure a sliding of the guide rail 23 (not shown).

15 Figure 4 shows a detail view for locking the housing 1 (housing omitted in the figure). The locking piece 27 is pushed with the groove 37 downwards over the tube 19a, 19c and the guide rail 23. Once the locking piece 27 has passed the guide rail it is twisted by 180° along the arrow 45. The housing 1 (not shown) can now be pushed over the tube and locked with the lock 33.

20

## List of reference numbers

	1	U-part
	3	First limb, side wall
5	5	Second limb, side wall
	6	Housing-cover
	7	Bottom side wall
	9	Opening
	11	Pipe section
10	13	Directional arrow
	15	Connector
	17	Connecting socket
	19	Tube
	21	Groove rail
15	23	Guide rail
	25	Connector
	27	Locking piece
	29	Component box
	31	Cutout
20	33	Lock
	35	Groove, channel
	37	Groove, lock
	39	Display
	41	Wall connecting plate
25	43	Wall
	45	Rotation arrow

### Patentkrav

1. Apparat med et rør (19) og med et herpå monterbart hus til en strømopladningsboks til elektrokøretøjer med tre sidevægge (3, 5, 7) og et låg (6), hvorved  
5 der i en første sidevæg (3) er tildannet en åbning (9) til indføringen af røret (19), hvorved de tre sidevægge (3, 5, 7) er indrettet i form af et U, hvorpå åbningen (9) er tilvejebragt den sidevæg (3), som danner det første ben, hvorpå det andet ben, som danner den over for beliggende sidevæg (5) er forbundet med et med  
10 åbningen (9) flugtende rørstykke (11), hvis tværsnit, især diameter, er større eller mindre end tværsnittet af røret (19), hvorved røret (19) har et igennem åbningen (9) indført rørafsnit (19a), og hvorved rørafsnittet (19a) og rørstykket (11) indrettet til at kunne skydes ind i hinanden og i sammenskudt tilstand er låsbart, **kendetegnet ved**,
  - 15 - at der på den over for den første sidevæg (3) beliggende sidevæg (5) i rørstykket (11) er fastgjort en første del (15) af en elektrisk stikforbindelse flugtende med åbningen (9), og at rørafsnittet (19a) på sin frie ende har et modstykke (17) til den første del af stikforbindelsen og en udragende længde til, når den er ført ind igennem åbningen (9), at etablere stikforbindelsen  
20 imellem stikforbindelsens to dele (17, 15).
2. Apparat ifølge krav 1, **kendetegnet ved**, at den tredje sidevæg (3) dannes af en bukket del af låget (6) eller en del af rørafsnittets (19a) sideflade.
- 25 3. Apparat ifølge krav 1 eller 2, **kendetegnet ved**, at rørafsnittet (19a) er rundt og på den cylindriske side har en parallelt med rørafsnittets (19a) midterakse forløbende aflang udbukning (23), som er formssluttende tilpasset en udsparring på kanten af åbningen (9).
- 30 4. Apparat ifølge krav 3, **kendetegnet ved**, at udsparringen (31) danner starten af en not (35), som dannes ved hjælp af en op til udsparringen (31) stødende profilskinne (21), som strækker sig frem til den over for beliggende sidevæg (5) og der er forbundet med denne.

5. Apparat ifølge et af kravene 1 til 4, **kendetegnet ved**, at i det mindste tre sidevægge (3, 5, 7) danner en ud i ét tildannet pladedel, som er afrundet ved sine hjørner og/eller kanter.
- 5 6. Apparat ifølge et af kravene 1 til 5, **kendetegnet ved**, at der på i det mindste en yderligere sidevæg er anbragt i det mindste en del (15) af en yderligere stikforbindelse.
7. Apparat ifølge et af kravene 1 til 6, **kendetegnet ved**, at åbningen (9) befin-  
10 der sig i den øvre del af den første sidevæg (3).
8. Apparat ifølge et af kravene 1 til 7, **kendetegnet ved**, at røret (19) er retvinklet bukket, således at der dannes to med forskellig længde tildannede rørfafsnit (19a, 19b), hvoraf det korte rørfafsnit (19a) er ført igennem åbningen (9), og  
15 det lange rørfafsnit (19b) er fastgjort med sin ende på jorden.
9. Apparat ifølge et af kravene 1 til 8, **kendetegnet ved**, at huset indeholder i det mindste følgende dele:
- 20 - mindst en yderligere bøsning (25), sokkel eller et stik,  
- et på låget fastgjort display (39),  
- et indre hus (29) til beskyttelse af elektriske komponenter.

1

Fig. 1

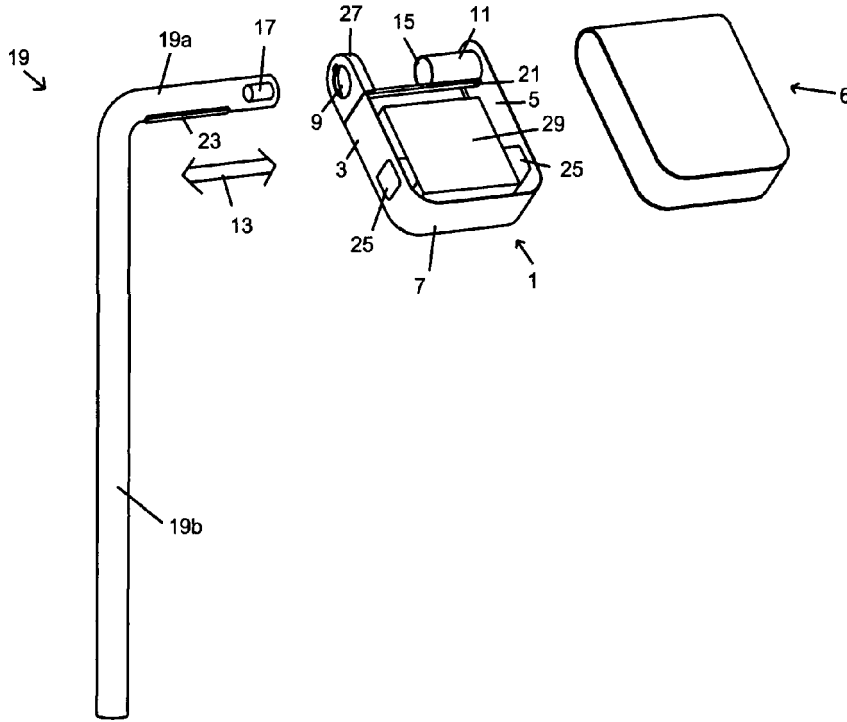
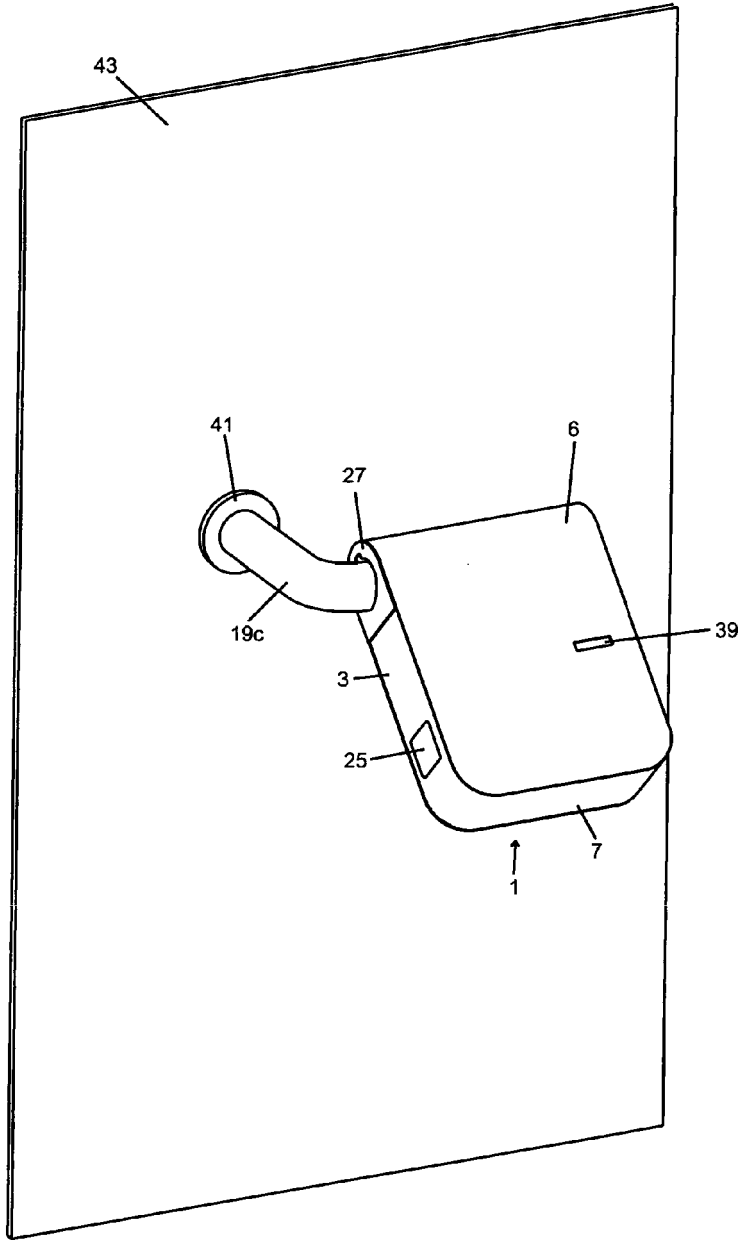

Fig. 2



3

Fig. 3

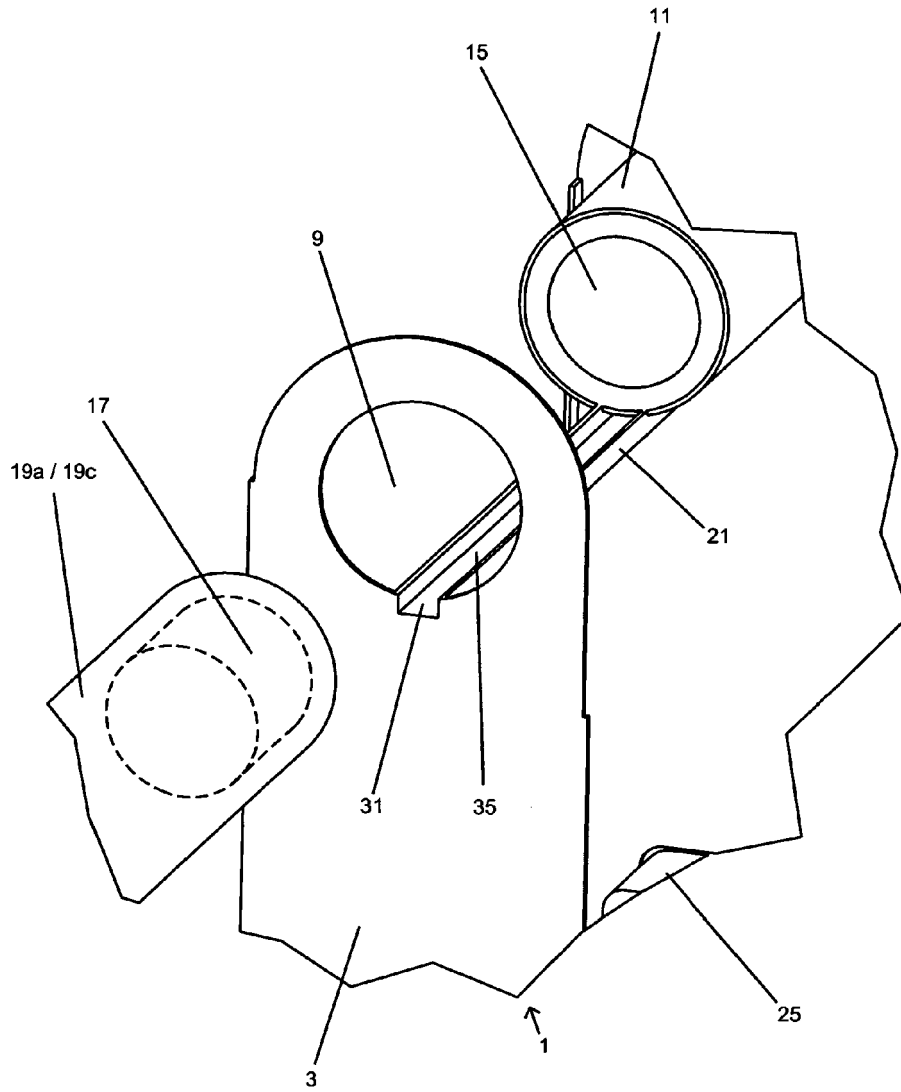

Fig. 4

