

FOR THE PURPOSES OF INFORMATION ONLY

Codes used to identify States party to the PCT on the front pages of pamphlets publishing international applications under the PCT.

AL	Albania	ES	Spain	LS	Lesotho	SI	Slovenia
AM	Armenia	FI	Finland	LT	Lithuania	SK	Slovakia
AT	Austria	FR	France	LU	Luxembourg	SN	Senegal
AU	Australia	GA	Gabon	LV	Latvia	SZ	Swaziland
AZ	Azerbaijan	GB	United Kingdom	MC	Monaco	TD	Chad
BA	Bosnia and Herzegovina	GE	Georgia	MD	Republic of Moldova	TG	Togo
BB	Barbados	GH	Ghana	MG	Madagascar	TJ	Tajikistan
BE	Belgium	GN	Guinea	MK	The former Yugoslav Republic of Macedonia	TM	Turkmenistan
BF	Burkina Faso	GR	Greece	ML	Mali	TR	Turkey
BG	Bulgaria	HU	Hungary	MN	Mongolia	TT	Trinidad and Tobago
BJ	Benin	IE	Ireland	MR	Mauritania	UA	Ukraine
BR	Brazil	IL	Israel	MW	Malawi	UG	Uganda
BY	Belarus	IS	Iceland	MX	Mexico	US	United States of America
CA	Canada	IT	Italy	NE	Niger	UZ	Uzbekistan
CF	Central African Republic	JP	Japan	NL	Netherlands	VN	Viet Nam
CG	Congo	KE	Kenya	NO	Norway	YU	Yugoslavia
CH	Switzerland	KG	Kyrgyzstan	NZ	New Zealand	ZW	Zimbabwe
CI	Côte d'Ivoire	KP	Democratic People's Republic of Korea	PL	Poland		
CM	Cameroon	KR	Republic of Korea	PT	Portugal		
CN	China	KZ	Kazakstan	RO	Romania		
CU	Cuba	LC	Saint Lucia	RU	Russian Federation		
CZ	Czech Republic	LI	Liechtenstein	SD	Sudan		
DE	Germany	LK	Sri Lanka	SE	Sweden		
DK	Denmark	LR	Liberia	SG	Singapore		
EE	Estonia						

SOIL REINFORCEMENT

This invention relates to reinforced soil structures, and it is particularly concerned with a method of and apparatus for securing flexible polymeric strips to a facing for such a structure.

The technique of using polymeric strips in compacted granular fill behind a lightweight reinforced concrete facing is well known, and several ways of connecting the strips to the facing have been employed. For instance, metallic loops are secured to the panels which form the facing, and the strip is circumflected alternately about the loops and anchoring points within the fill.

The present invention provides a facing element for a facing of a reinforced soil structure comprising a polymeric strip circumflected about an attachment member, wherein the element defines a first chamber for receiving the member and a portion of the circumflected strip, and a second chamber laterally adjoining and connected to the first chamber for receiving and retaining the member and the circumflected strip portion therein, the chambers opening to the rear face of the element.

Preferably, the relative dimensions of the second chamber and the attachment member serve to retain an interjacent strip portion in wedged engagement therebetween. Subsequent movement of the facing or the strip e.g. as the soil structure settles, wedges the attachment member and the interjacent strip portion more securely within the second chamber.

The fibres in the strip can be damaged by excessive compressive loading and thus in a preferred embodiment opposed converging surfaces of the second chamber define an abutment zone, the converging surfaces and the adjacent attachment member surfaces being substantially parallel over the area of the abutment zone when the interjacent strip portion is wedged therebetween thereby to spread the load on the interjacent strip portion over the area of the abutment

zone.

According to another aspect of the invention, there is provided an assembly for use in a reinforced soil structure comprising a polymeric strip, the assembly comprising an attachment member and a facing element as defined above.

To improve the resistance of the attachment member to corrosion, the attachment member is preferably formed from non-metallic material.

The invention also provides a method of securing a polymeric strip to a facing element of a reinforced soil structure, the method comprising the steps of:

circumflexing the strip about an attachment member;
inserting the attachment member and a portion of the circumflexed strip into a first chamber opening to the rear of the element; and
moving the attachment member and the strip portion laterally into a second chamber for receiving and retaining the attachment member and the circumflexed strip portion, the second chamber adjoining and connecting to the first chamber and opening to the rear of the element.

A clear understanding of the invention will be gained from the following detailed description of embodiments, given by way of example only, with reference to the accompanying drawings, in which:

Figure 1 is an illustrative perspective view of an opening and associated chambers in an element according to the invention;

Figure 2 is a rear view of one embodiment of an element;

Figure 3 is a cross-sectional view through a reinforced structure

incorporating the invention;

Figure 4 is an illustrative cross-sectional view through an element and attachment member *in situ*; and

Figures 5a to d are similar views to Figure 4 showing alternative embodiments of the invention.

A facing for a reinforced soil structure is generally formed by an isodamous arrangement of panels or blocks e.g. of concrete, steel or fibreglass. The panels may interengage or interlock to strengthen the facing, and to distribute the load placed on the individual panels. The facing is supported against the loads imposed by the soil structure by strips of polymeric material which are secured to the facing and which extend from the facing into the soil structure.

Figure 1 illustrates a substantially rectilinear opening or entrance, generally designated 20, in the rearward face of a panel 10. The opening has a first aperture 21 adjacent a second, relatively restricted, aperture 22. The first and second apertures 21,22 communicate with respective first and second chambers 2,3. The first chamber 2 has a generally parallelepiped configuration. The second chamber 3 has a substantially frustocunate inner portion 4 tapered toward a contiguous generally parallelepiped outer portion 5. The height of the second aperture 22 and the outer portion of the second chamber 3 are less than that of the first aperture 21 and the chamber 2. The apertures 21,22 and the respective chambers 2,3, which together define a cavity 1, adjoin along a common edge or face to allow communication between them.

A polymeric strip, i.e. a strip 6 of drawn or aligned fibres encased in a protective sheath of PVC or polyethylene, which is to be secured to the panel is circumflected about an elongate rod or beam 7. The depth and width of the strip

6 are typically in the ranges 1 to 2 mm and 80 to 90 mm respectively. The rod 7 is preferably formed from polypropylene, polyethylene, glass-filled polyethylene or any other suitable polymer. Other examples of material the rod could be formed from include ceramics, a carbon fibre composite material or a corrosion resistant metallic material. The front edge of the outer portion 5 of the second chamber 3 may be rounded to avoid damage to the polymeric strip.

To secure the strip 6 to the panel 10, the rod 7 and the adjacent circumflected portion 8 of the strip 6 are inserted into the first aperture 21 (movement A). After insertion, the circumflect portion 8 of the strip 6 and the rod 7 are moved laterally (B) to position the rod 7 and the circumflect portion 8 behind the second aperture 22. The relative dimensions of the rod 7 and the second aperture 22 prevent the removal of the rod 7 and the adjacent portion 8 of the strip 6 thereby securing the strip to the panel. Positioning the rod 7 in the frustocunate inner portion 4 of the second chamber results in tensioning (C) of the strip 6 bringing the rod 7 and the adjacent circumflected portion 8 of the strip 6 into wedged engagement with the inner portion 4 of the second chamber 3. The height of the second aperture 22 and the outer portion 5 of the second chamber are sufficient to accommodate two thicknesses of the strip 6, but they are too small for the attachment member and the adjacent portion of the strip to fit through. After the strip is tensioned, the first aperture 21 and the associated chamber are filled, e.g. with mortar, to seal the rod 7 within the block and thus ensure that the strip cannot become detached from the structure.

To form the cavity 1, a mould or cast, e.g. of polystyrene, PVC or low density polyethylene, corresponding to the shape of the cavity is positioned within the frame in which the panel 10 is formed, concrete or another suitable material is poured into the frame, and the mould is dismantled or destroyed and removed after the concrete panel 10 has set. The mould may be sculpted from a single piece of material, or it could be formed by a number of distinct sections

which are secured together by a suitable adhesive or other fasteners. Preferably, the section of the mould which defines the second chamber 3 is formed by extrusion.

The specific configuration of the cavity may vary. The first aperture 21 and the chamber 2 may be of any configuration, e.g. hemispherical or cylindrical, but the size of the first aperture and chamber should be sufficient to accommodate the rod 7 and the circumflected portion 8 of the strip 6 and to enable the rod 7 and strip 6 to be moved into the adjoining second chamber 3. Also, the inner portion 4 of the second chamber need not be wedge-shaped, and it could for instance be cylindrical, trapezoidal or quadriform in configuration (see Figure 5). However, the second chamber should define an inner portion capable of receiving the member and the strip and a barrier or bottleneck between the inner portion and the rear of the panel of a width less than the width of the rod 7 together with two thicknesses of the strip 6 but greater than two thicknesses of the strip 6 for retaining the member 7 and the adjacent portion of the strip 6. The junction between the inner and outer portions 4,5 of the second chamber 3 may be rounded to reduce the chance of damage to the abutting portion of the strip 6.

Also, the rod 7 and the second chamber 3 can be configured to have elongate parallel surfaces in the abutment zone, i.e. the area in which the rod and the second chamber sandwich the strip 8. For instance if the inner portion of the second chamber is wedge-shaped the rod can be substantially pear-shaped (Figure 5a). The enlargement of the abutment zone reduces the intensity of the compressive load on the sandwiched portion of the strip and on the rod 7. The load on the rod 7 may be reduced to the extent that it can be formed from a cementitious material such as cement grout.

The width and depth of the strip are typically in the ranges of 80 mm to 90 mm and 1 mm to 2 mm respectively. The length of the rod is equal to or greater than the strip width, and if the width of the strip is in the range of 80 mm

to 90 mm, the rod length may be approximately 100 mm. The compressive load on the strip can be significantly reduced by having the surfaces in the abutment zone parallel over a length of at least 20 mm, and preferably the surfaces are parallel over 30 mm to 40 mm.

During construction of a reinforced soil structure, the facing and soil e.g. compacted granular fill 30, are built up in layers. The panels according to the invention may be interspersed with conventional panels, i.e. panels without a cavity for receiving and retaining the polymeric strip. A drainage layer may be provided immediately behind the facing and a geotextile strip 32 may be disposed between the granular fill 30 and the drainage layers 31 to prevent soil particles clogging up the drainage layer.

One or more anchoring bars or shafts are disposed in the soil behind the facing on the same horizontal levels as the assemblies or elements according to the invention. A continuous portion of strip 5 is circumflected about a first rod 7, an anchoring bar, a second rod adjacent the first rod etc., to produce a zig-zag strip configuration.

Of course, modifications to the described embodiments may be made without departing from the scope of the invention. For instance the rear face 11 of the panel 10 may be buttressed or otherwise reinforced in the region of the cavity if the thickness of the panel in that area is not sufficient to withstand the load imposed by the strip on the panel. Also, more than one cavity can be disposed in a single panel, and for instance a cavity could be located near each corner of the panel (see Figure 2). Further, the cavity may be accessible from both the front and the back of the panel to facilitate the location of the attachment member. The panel and the rod should be configured to avoid sharp corners in the areas of contact with the strip to minimise the chances of damage to the strip.

CLAIMS

1. A facing element for a facing of a reinforced soil structure comprising a polymeric strip (6) circumflected about an attachment member (7), wherein the element defines a first chamber (2) for receiving the member and a portion of the circumflected strip, and a second chamber (3) laterally adjoining and connected to the first chamber for receiving and retaining the member and the circumflected strip portion therein, the chambers opening to the rear face of the element.
2. A facing element according to claim 1, wherein the relative dimensions of the second chamber (3) and the attachment member (7) serve to retain an interjacent strip portion in wedged engagement therebetween.
3. A facing element according to claim 2, wherein opposed converging surfaces of the second chamber define an abutment zone, the converging surfaces and the adjacent attachment member surfaces being substantially parallel over the area of the abutment zone when the interjacent strip portion is wedged therebetween thereby to spread the load on the interjacent strip portion over the area of the abutment zone.
4. A facing element according to claim 3, wherein the converging surfaces are substantially planar.
5. A facing element according to claim 1, 2, 3 or 4 wherein the first and second chambers (2,3) together define a cavity, and a plurality of cavities are provided.

6. A facing element according to claim 5 wherein a cavity is provided in the region of each corner of the element.
7. A facing element according to any one of the preceding claims wherein the first chamber (2) opens to the front of the element.
8. A facing element according to any one of the preceding claims wherein the second chamber (3) opens to the front of the element.
9. A reinforced soil structure comprising a facing element according to any one of the preceding claims.
10. An assembly for use in a reinforced soil structure comprising a polymeric strip (6), the assembly comprising an attachment member (7) and a facing element as defined in any one of claims 1 to 8.
11. An assembly according to claim 10, wherein the attachment member (7) is formed from a non-metallic material.
12. An assembly according to claim 11, wherein the attachment member (7) is formed from a cementitious material.
13. An assembly according to any one of claims 10, 11 or 12 wherein the cross section of the attachment member (7) is substantially wedge-shaped.
14. A reinforced soil structure comprising an assembly according to any one of claims 10, 11, 12 or 13.

15. A method of securing a polymeric strip (6) to a facing element of a reinforced soil structure, the method comprising the steps of:

circumflecting the strip (6) about an attachment member (7);

inserting the attachment member (7) and a portion of the circumflected strip into a first chamber (2) opening to the rear of the element; and

moving the attachment member and the strip portion laterally into a second chamber (3) for receiving and retaining the attachment member and the circumflected strip portion, the second chamber adjoining and connecting to the first chamber and opening to the rear of the element.

16. A method according to claim 15 wherein the strip (6) and attachment member (7) are pulled into wedged engagement with opposed converging surfaces of the second chamber.

17. A method according to claim 16 wherein the first chamber is sealed to prevent withdrawal of the attachment member subsequent to the movement of the attachment member (7) and the circumflected strip portion (7) into the second chamber (3).

1/4

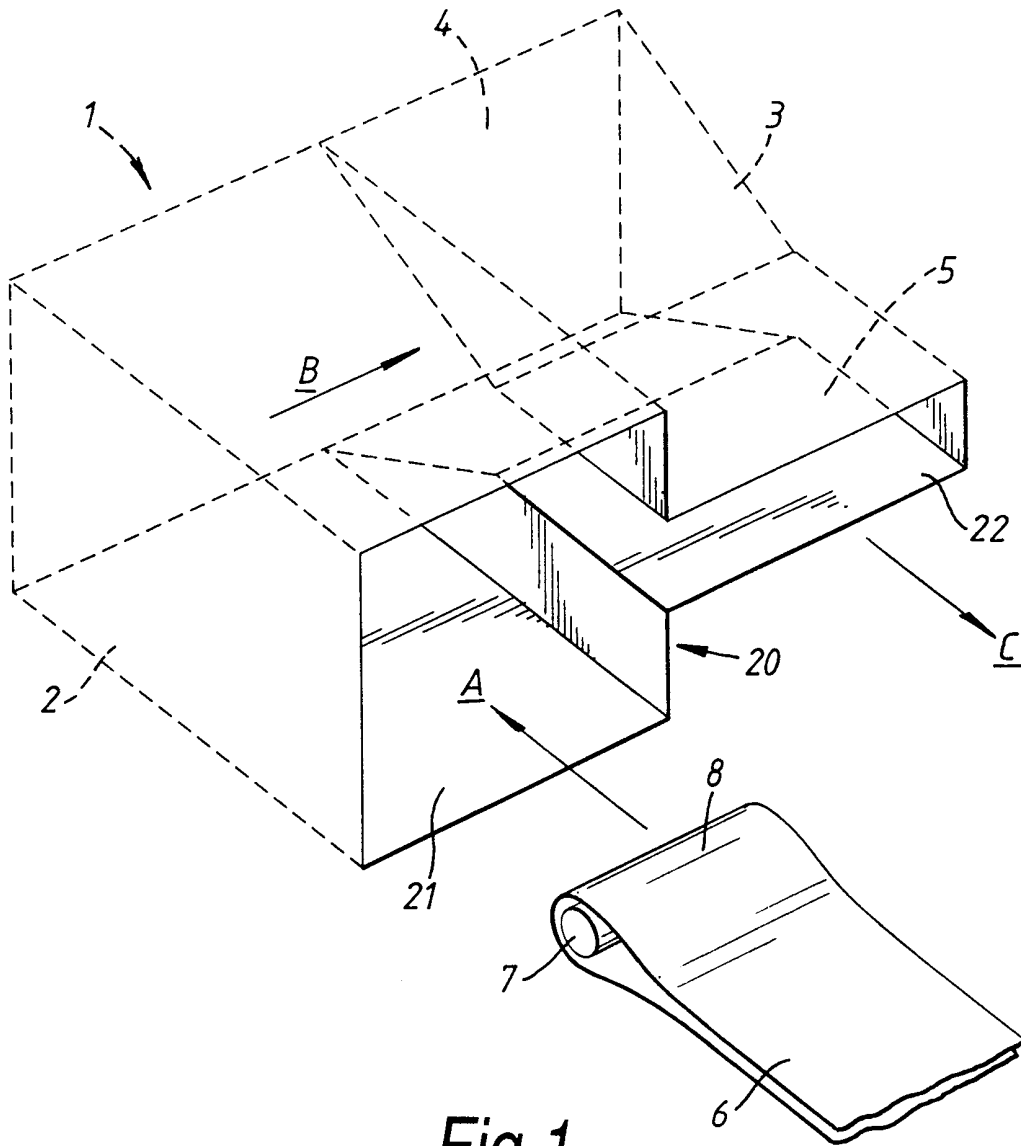

Fig. 1

2/4

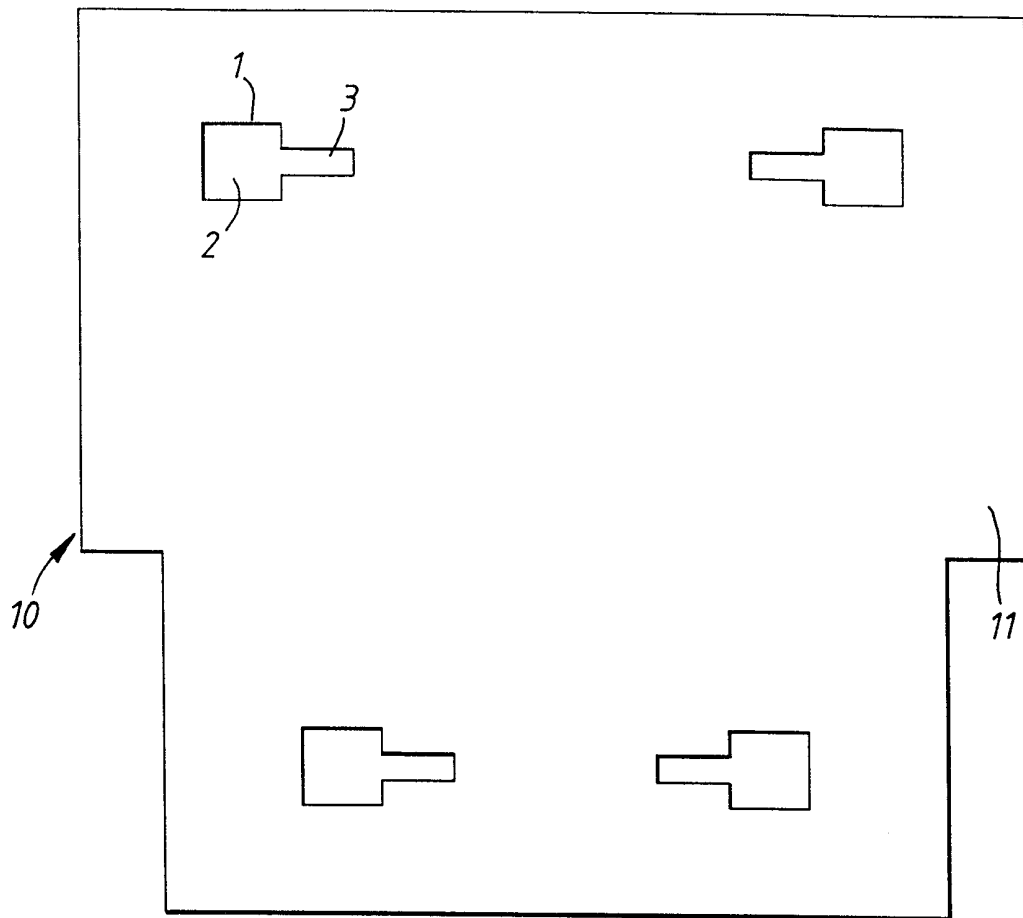

Fig.2

3/4

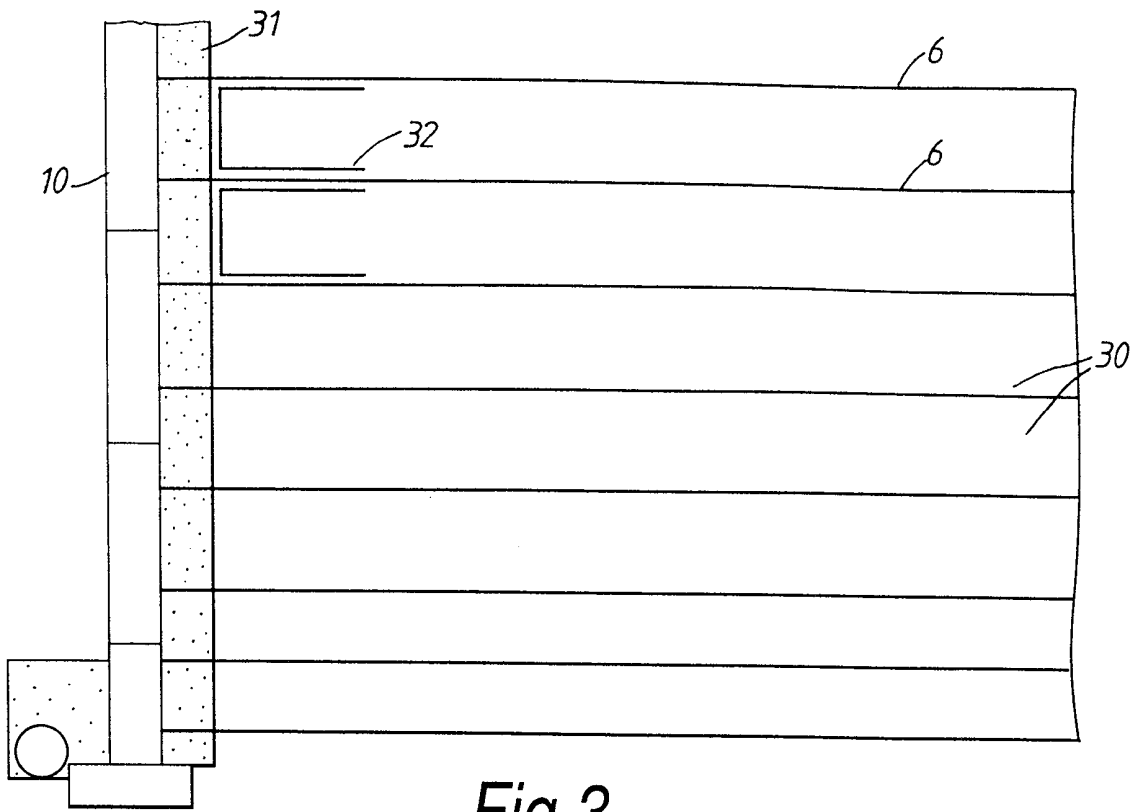

Fig.3

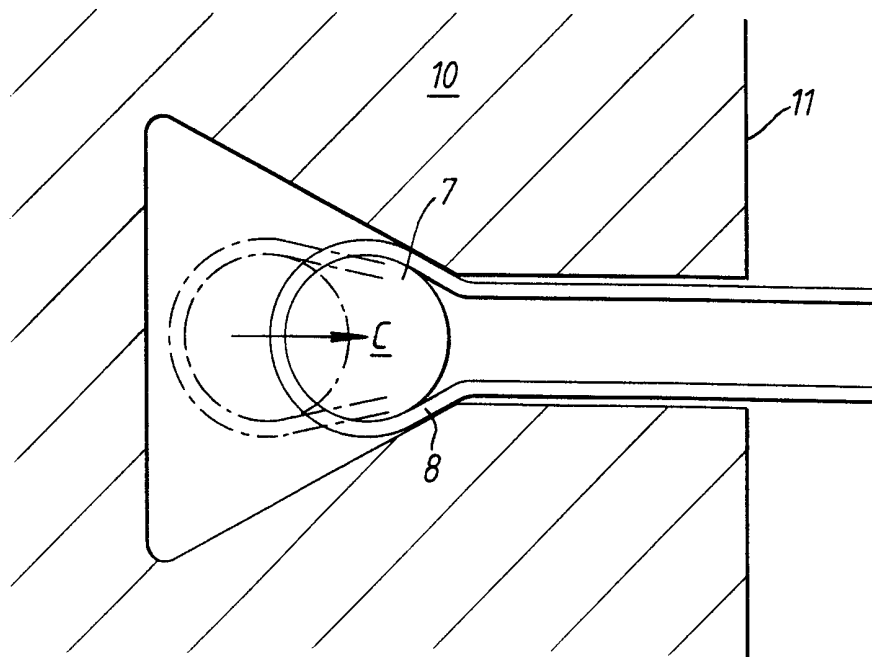

Fig.4

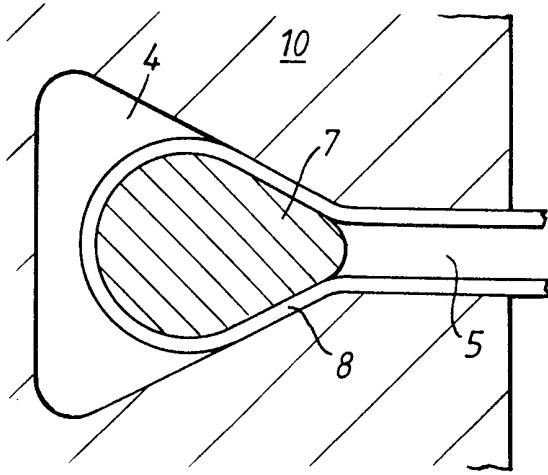

Fig. 5a

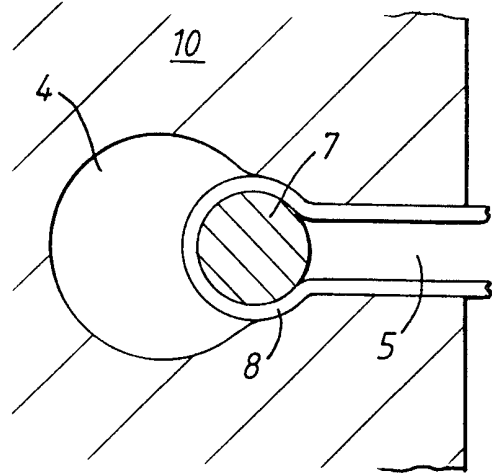

Fig. 5b

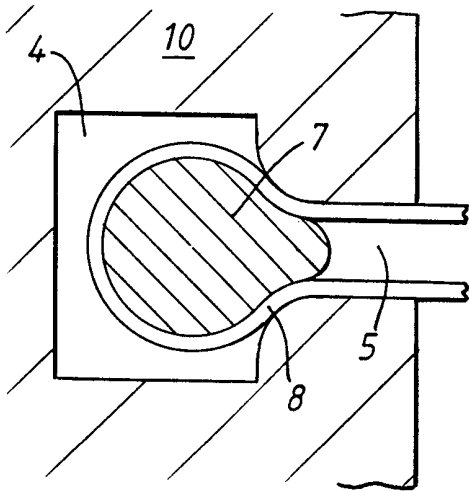

Fig. 5c

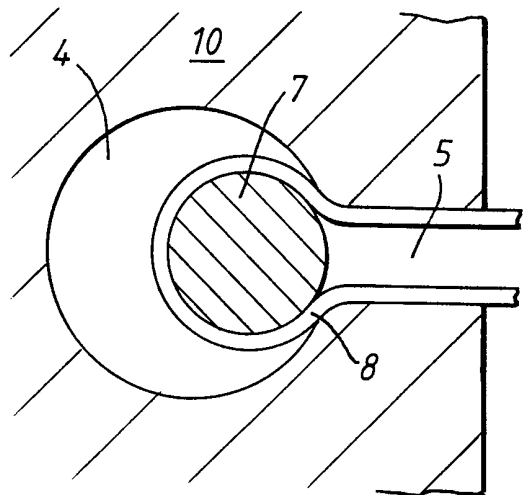

Fig. 5d

INTERNATIONAL SEARCH REPORT

Intern. Patent Application No
PCT/GB 98/02912

A. CLASSIFICATION OF SUBJECT MATTER
IPC 6 E02D29/02

According to International Patent Classification (IPC) or to both national classification and IPC

B. FIELDS SEARCHED

Minimum documentation searched (classification system followed by classification symbols)
IPC 6 E02D E04G

Documentation searched other than minimum documentation to the extent that such documents are included in the fields searched

Electronic data base consulted during the international search (name of data base and, where practical, search terms used)

C. DOCUMENTS CONSIDERED TO BE RELEVANT

Category °	Citation of document, with indication, where appropriate, of the relevant passages	Relevant to claim No.
A	DE 29 24 310 A (BETONUTEPITOE VALLALAT) 3 January 1980 see page 8, line 6 - page 9, line 22; figures 1-6 ---	1,5,6, 9-11,14, 15
A	GB 2 014 222 A (TRANSPORT SECRETARY OF STATE F) 22 August 1979 see page 1, line 128 - page 3, line 49; figures 1-9 ---	1,6-10, 14,15
A	US 4 824 293 A (BROWN RICHARD L ET AL) 25 April 1989 see the whole document ---	1,9,10, 14,15
-/--		

Further documents are listed in the continuation of box C.

Patent family members are listed in annex.

° Special categories of cited documents :

- "A" document defining the general state of the art which is not considered to be of particular relevance
- "E" earlier document but published on or after the international filing date
- "L" document which may throw doubts on priority claim(s) or which is cited to establish the publication date of another citation or other special reason (as specified)
- "O" document referring to an oral disclosure, use, exhibition or other means
- "P" document published prior to the international filing date but later than the priority date claimed

- "T" later document published after the international filing date or priority date and not in conflict with the application but cited to understand the principle or theory underlying the invention
- "X" document of particular relevance; the claimed invention cannot be considered novel or cannot be considered to involve an inventive step when the document is taken alone
- "Y" document of particular relevance; the claimed invention cannot be considered to involve an inventive step when the document is combined with one or more other such documents, such combination being obvious to a person skilled in the art.
- "&" document member of the same patent family

Date of the actual completion of the international search

Date of mailing of the international search report

8 December 1998

16/12/1998

Name and mailing address of the ISA

European Patent Office, P.B. 5818 Patentlaan 2
NL - 2280 HV Rijswijk
Tel. (+31-70) 340-2040, Tx. 31 651 epo nl,
Fax: (+31-70) 340-3016

Authorized officer

Tellefsen, J

INTERNATIONAL SEARCH REPORT

Interr. Application No PCT/GB 98/02912

C.(Continuation) DOCUMENTS CONSIDERED TO BE RELEVANT

Category *	Citation of document, with indication, where appropriate, of the relevant passages	Relevant to claim No.
A	WO 94 13890 A (GEOBLOCK INTERFACE ;MARTIN CHRISTOPHER (GB)) 23 June 1994 see page 5, line 12 - page 16, line 8; figures 1-19 <p style="text-align: center;">-----</p>	1-5, 9, 10, 14-17

INTERNATIONAL SEARCH REPORT

Information on patent family members

International Application No

PCT/GB 98/02912

Patent document cited in search report	Publication date	Patent family member(s)	Publication date
DE 2924310 A	03-01-1980	AT 374855 B AT 425379 A CS 229624 B	12-06-1984 15-10-1983 18-06-1984
GB 2014222 A	22-08-1979	NONE	
US 4824293 A	25-04-1989	NONE	
WO 9413890 A	23-06-1994	AT 160608 T AU 673039 B AU 5658194 A CA 2151955 A DE 69315445 D DE 69315445 T EP 0677128 A ES 2111898 T GR 3026060 T JP 8507339 T NZ 258630 A US 5607262 A US 5800097 A	15-12-1997 24-10-1996 04-07-1994 23-06-1994 08-01-1998 14-05-1998 18-10-1995 16-03-1998 29-05-1998 06-08-1996 24-11-1997 04-03-1997 01-09-1998