

G. W. BROWN.
Corn-Planter.

No. 213,972.

Patented April 8, 1879.

Fig. 1

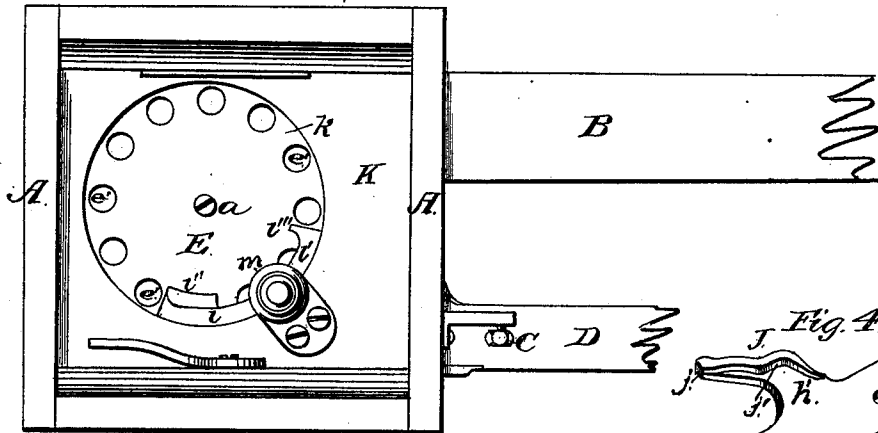

Fig. 2

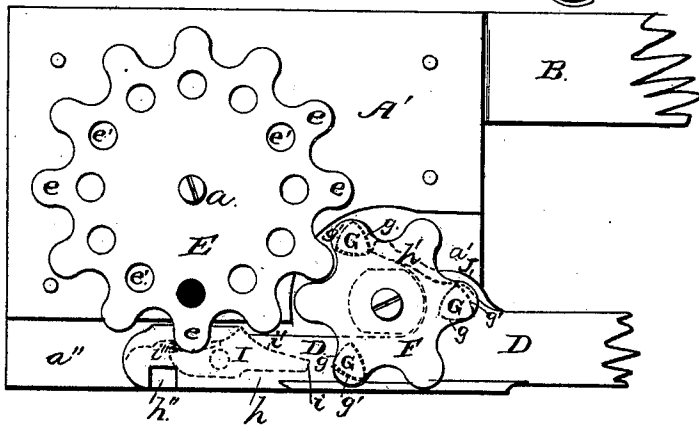
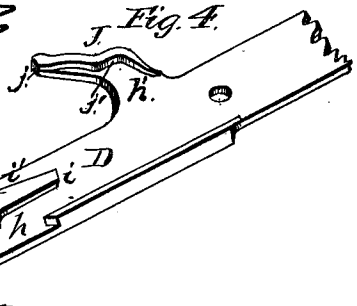
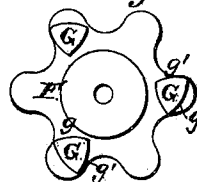

Fig. 3



Attest:
F. P. Brock
D. S. Stuart

Inventor:
George W. Brown
 by *W. B. Richards*
 Atty.

G. W. BROWN.
Corn-Planter.

No. 213,972.

Patented April 8, 1879.

Fig. 3.

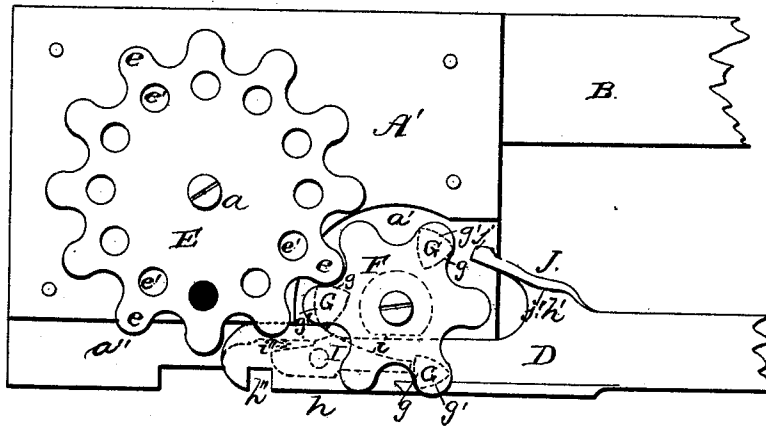

Fig. 6.

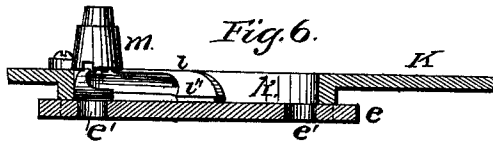

Fig. 7.

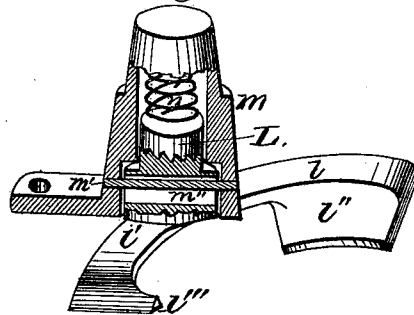
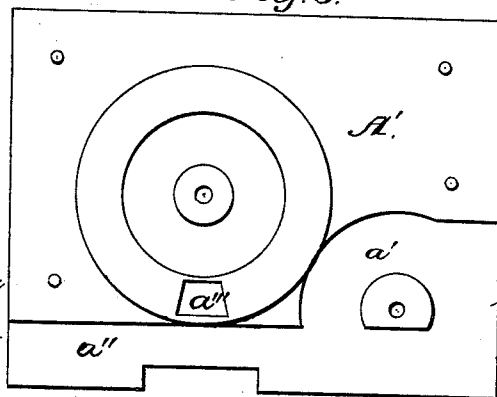

Fig. 8.



Attest:
F. D. Brock
D. S. Stuart

Inventor:
George W. Brown,
by W. B. Richards
Atty.

UNITED STATES PATENT OFFICE.

GEORGE W. BROWN, OF GALESBURG, ILLINOIS.

IMPROVEMENT IN CORN-PLANTERS.

Specification forming part of Letters Patent No. **213,972**, dated April 8, 1879; application filed December 27, 1878.

To all whom it may concern:

Be it known that I, GEORGE W. BROWN, of Galesburg, in the county of Knox and State of Illinois, have invented certain new and useful Improvements in Corn-Planters; and I do hereby declare that the following is a full, clear, and exact description of the invention, which will enable others skilled in the art to which it appertains to make and use the same, reference being had to the accompanying drawings, and to letters of reference marked thereon, which form a part of this specification, in which—

Figure 1 is a top-plan view of a corn-planter seed-box embodying my invention. Fig. 2 is the same view as Fig. 1, with the seed-disk cap and the seed-box removed. Fig. 3 is the same view as Fig. 2, but the parts in different relative positions. Fig. 4 is a perspective view of the slide. Fig. 5 is a plan view of the drive-pinion, seen from the bottom. Fig. 6 is a sectional view of the cap, showing an elevation of the cut-off and stirrer. Fig. 7 is a perspective view of the parts shown at Fig. 6, partly broken away. Fig. 8 is a top-plan view of the seed-box bottom plate.

This invention relates to that class of corn-planters having rotary seed-cup disks actuated by a slide; and consists, first, in an intermediate pinion located between the seed-cup disk and the slide, so as to receive successive impulses from the slide, and impart an intermittent rotary motion to the seed-cup disk by gear-connection therewith; second, in combination with a seed-cup disk and with a slide having projecting cams, an intermediate pinion having projecting lugs, which coact with the cams on the slide, and which gear with the seed-cup disk; third, in combination with a reciprocating slide and a toothed pinion which receives motion therefrom, a seed-cup disk having a seed-cup to each cog, so that when removed for any purpose it may be properly replaced so as to register with the discharge by placing any set of its cogs in gear with said pinion; fourth, the invention further consists in a cut-off and leveler or stirrer on opposite ends of an arm which is arranged so that it can rise to allow the stirrer and cut-off to rise simultaneously, or so that either

end can rise, to permit them to rise to a certain extent independently.

Referring to the drawings by letters, letter A represents the seed-box; B, a part of the framing; C, the hand-lever for actuating the slide-bar D, which extends across the machine from one seed-box to the other.

The foregoing parts do not differ in construction from an ordinary corn-planter, except as hereinafter noted.

The seed-tubes and other parts of the planter are not shown in the drawings, and may be of any ordinary construction.

E is the circular seed-cup disk, journaled by a stud-bolt, *a*, to the bottom plate, A', of the seed-box, and has a series of cogs, *e*, around its periphery, with an orbital series of perforations or seed-cups, *e'*, interior to and corresponding in number with the cogs *e*.

F is a pinion, journaled to the plate A in gear with the disk E, and has lugs G projecting from its lower side, each lug constructed with two cam-faces, *g g'*, arranged relatively to each other, as shown in the drawings. The pinion F is seated in a recess, *a'*, in the plate A', preferably in one corner of the box A.

D is the slide, with one arm, *h*, which operates in a groove, *a''*, in the plate A', to one side of the center of the pinion F, and another arm, *h'*, which slides in the recess *a'*. The arm *h* has an upwardly-projecting cam, I, with two faces, *i i'*, and the arm *h'* has a similarly-projecting cam, J, with faces *j j'*. The projecting parts, which form the faces *i* and *j*, may be pivoted and held by a spring, *i''*, so as to have a yielding motion, as shown by the cam I at Fig. 2 of the drawings, or may be made rigid, as shown by the cam J at same figure.

The cams I and J are in the same horizontal plane as the cam-lugs G, so that they may coact, as follows:

As the slide D is thrust forward to carry it to the end of its throw to the left hand, as shown at Fig. 2 of the drawings, the cam-face *j* of the cam J will impinge against a cam-face, *g*, of one of the lugs G, and rotate the pinion F one-sixth of a revolution, or until its motion is arrested by the face *g'* of the next lug G coming in contact with the face *j'*. This partial rotation of the pinion F will rotate the

seed-cup disk E the distance between the centers of two cogs, c , and bring one of the seed-cups e' beneath the cut-off, hereinafter described, and so as to register with a discharge-opening, a'' , in the bottom plate A'.

Each seed-cup may be represented by two or more cups, if desired.

A return movement of the slide to the right-hand end of its throw, as shown at Fig. 3, will cause the cam-faces i' to act on two of the cam-lugs G in a similar manner to that last described, and will give the pinion F another one-sixth of a rotation in the same direction as last described, and with the same result on the seed-cup disk. The cams j' , resting between the lugs G at the end of the throw to the left hand, will prevent movement of the pinion F or disk E, and the cams i' will have the same effect at the other end of the throw, as shown at Figs. 2 and 3, and the same parts will act as stops to limit the throw of the slide; or any suitable stops may be provided.

The cams i and j , if made yielding, as shown by the cam i in the drawings, cannot be made to lock the parts by their points coming in contact with a point of one of the lugs G when the pinion F is displaced by any accidental cause after the slide has commenced its throw.

The slide D has a recess, h'' , in its side, which receives and vibrates the discharge-valve (not shown in the drawings) in the ordinary manner.

K is the ordinary cap-plate, with a central opening, k , to allow the seed to come in contact with the seed-cups e' . L is a standard, loosely placed in a hollow bracket, m , which projects upward from the cap K, and is retained by a pin, m' , which passes through a slot, m'' , in the standard L, so as to allow the standard to rise and fall, and also to oscillate slightly. The standard L is held downward by a spring, n , and has arms l' projecting in opposite directions from its lower end. The arms l' are curved downward at their outer ends, and the one, l , has an ordinary cut-off plate, l'' , on its outer end, and the other, l' , has a light arm, l''' , on its outer end, which acts as a stirrer to loosen up the seed above

as they approach the cut-off, and as a leveler to settle and strike off the seed in the seed-cup approaching the cut-off. The yielding standard L will allow the cut-off l'' and leveler l''' to rise and fall simultaneously or independently, as will be seen at Fig. 7.

The seed-cup disk having a seed-cup to each cog, when removed, may be properly replaced very readily and easily, as, in any position in which it will gear with the pinion F, it will register with the discharge.

In addition to other advantages, the introduction of the pinion F enables me to actuate the seed-cup disk by a slide which does not pass underneath nor to both sides of said disk.

What I claim as new is—

1. The combination, in a corn-planting machine, with the seed-cup disk and the slide, of an intermediate pinion located between the seed-cup disk and slide, and adapted to receive intermittent rotary motion from the slide and impart the same kind of motion to the seed-cup disk by gear-connection.

2. In combination with the pinion F, having cam-lugs, constructed as described, and the slide D, having cams coacting with said cam-lugs, the seed-cup disk, having gear-connection with said pinion, substantially as and for the purpose specified.

3. In combination with a pinion, F, and slide D, a seed-cup disk having a seed-cup or set of cups to each cog on its periphery, to facilitate its replacement when removed, substantially as and for the purpose specified.

4. In combination with a seed-cup disk, a stirrer, l''' , fixed to the outer end of an arm, l' , constructed substantially as shown and described, and which projects from the same yielding standard L from which the cut-off l'' projects in an opposite direction.

In testimony that I claim the foregoing as my own I affix my signature in presence of two witnesses.

GEORGE W. BROWN.

Witnesses:

I. S. PERKINS,
L. STEVENS.