



(19) **United States**
(12) **Patent Application Publication**
Gallagher et al.

(10) **Pub. No.: US 2011/0182243 A1**
(43) **Pub. Date: Jul. 28, 2011**

(54) **MESSAGING FOR PAGING A MOBILE STATION IN AN UNLICENSED MOBILE ACCESS TELECOMMUNICATIONS SYSTEM**

7,640,008, which is a continuation-in-part of application No. 10/688,470, filed on Oct. 17, 2003, now Pat. No. 7,127,250.

(76) Inventors: **Michael D. Gallagher**, San Jose, CA (US); **Rajeev Gupta**, Sunnyvale, CA (US); **Milan Markovic**, Pleasanton, CA (US); **Jianxiang (Jason) Shi**, Pleasanton, CA (US); **Joseph G. Baranowski**, Morgan Hill, CA (US)

(60) Provisional application No. 60/571,421, filed on May 14, 2004, provisional application No. 60/564,696, filed on Apr. 22, 2004, provisional application No. 60/530,141, filed on Dec. 16, 2003, provisional application No. 60/552,455, filed on Mar. 12, 2004, provisional application No. 60/419,785, filed on Oct. 18, 2002.

Publication Classification

(21) Appl. No.: **13/082,368**

(51) **Int. Cl.**
H04W 68/00 (2009.01)

(22) Filed: **Apr. 7, 2011**

(52) **U.S. Cl.** **370/328**

Related U.S. Application Data

(60) Division of application No. 11/129,134, filed on May 12, 2005, now Pat. No. 7,953,423, which is a continuation-in-part of application No. 11/013,883, filed on Dec. 15, 2004, now Pat. No. 7,640,008, which is a continuation-in-part of application No. 11/097,866, filed on Mar. 31, 2005, now Pat. No. 7,873,015, which is a continuation-in-part of application No. 10/688,470, filed on Oct. 17, 2003, now Pat. No. 7,127,250, which is a continuation-in-part of application No. 11/013,883, filed on Dec. 15, 2004, now Pat. No.

(57) **ABSTRACT**

Techniques for performing messaging between mobile stations (MSs) and UMA network controllers (UNCs) in an unlicensed mobile access network (UMAN). URR (UMA radio resource) messages are exchanged between an MS and one or more UNCs to perform various operations associated with UMAN. The MS may access the UMAN via a wireless access point (AP) that is communicatively coupled to the UNC via an IP network. The URR messages are sent between MSs and UNCs using an Up interface comprising a set of layered protocols over an underlying IP transport.

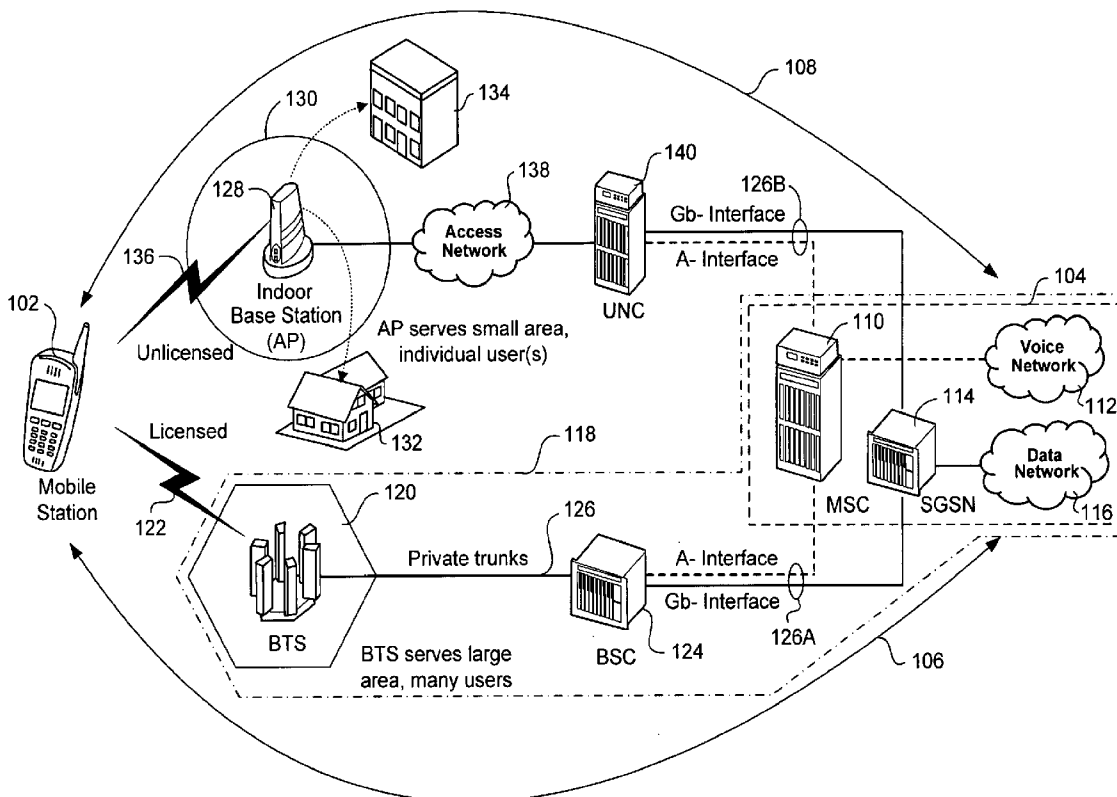

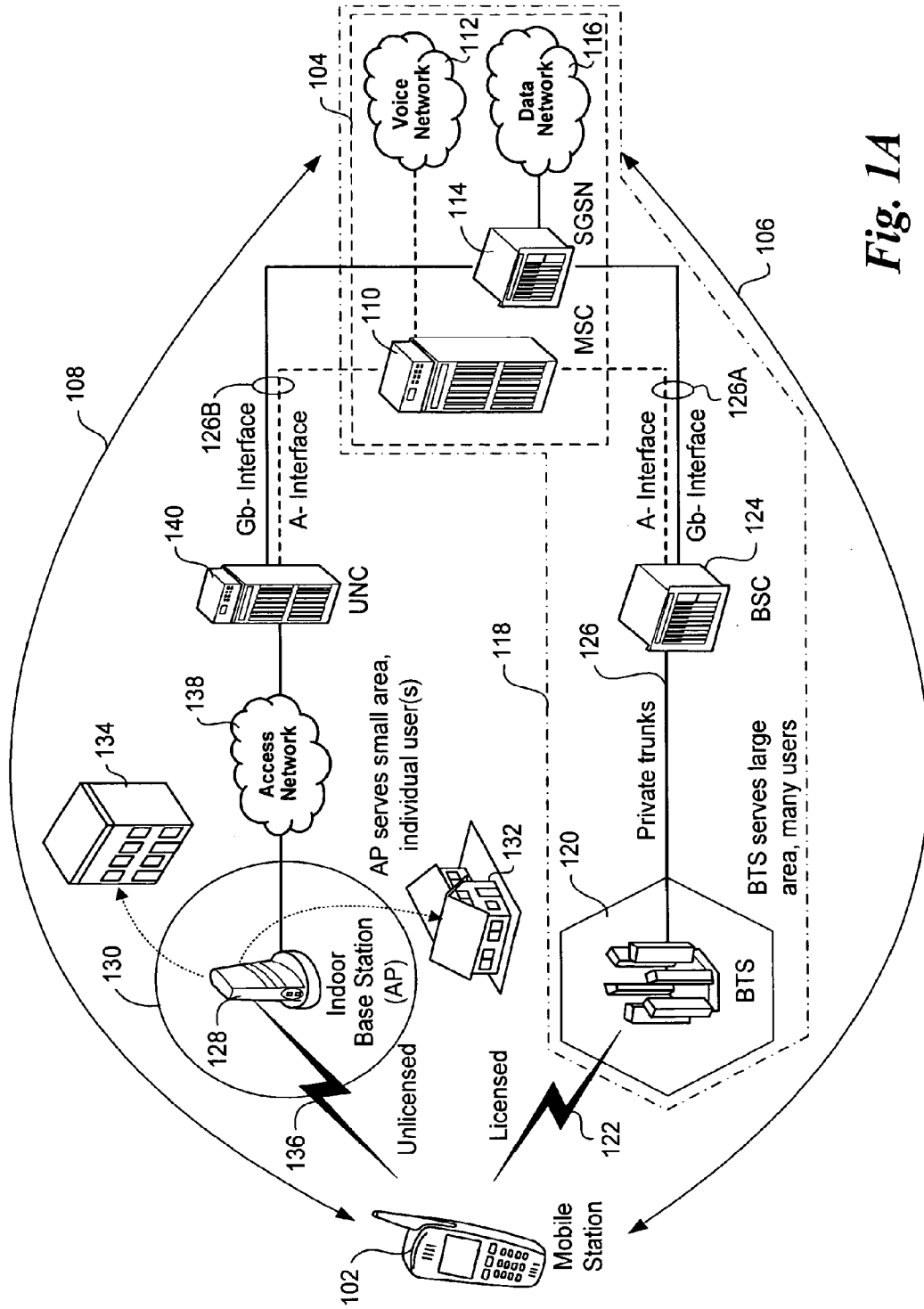

Fig. 1A

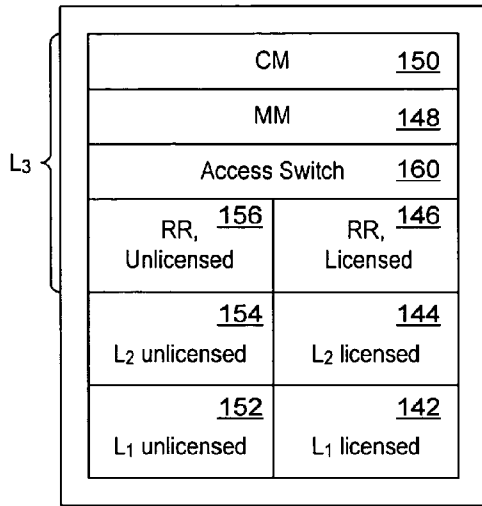

Fig. 1B

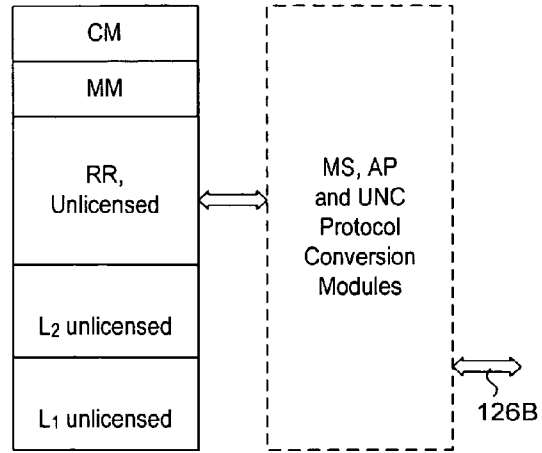

Fig. 1C

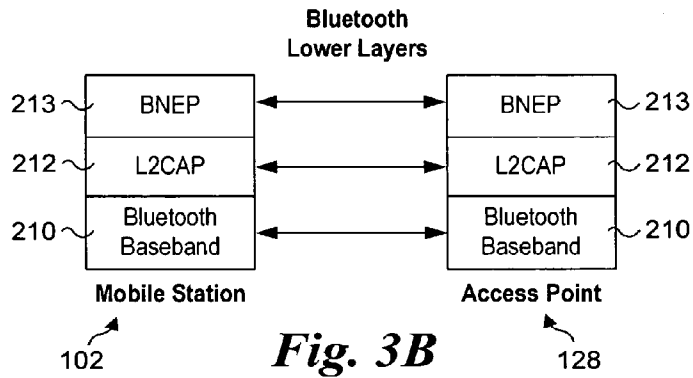

Fig. 3B

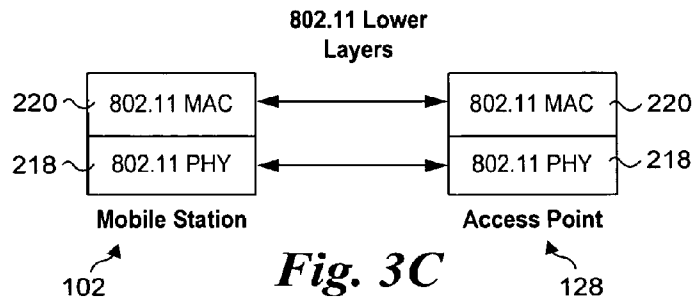

Fig. 3C

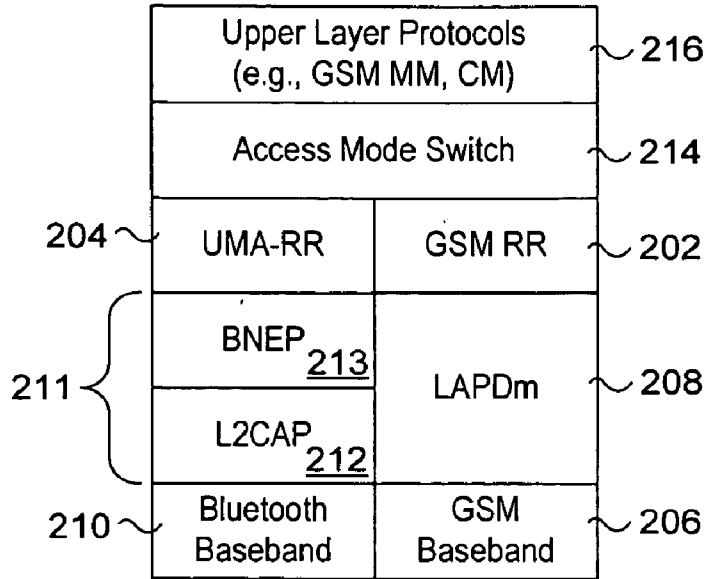

Fig. 2A

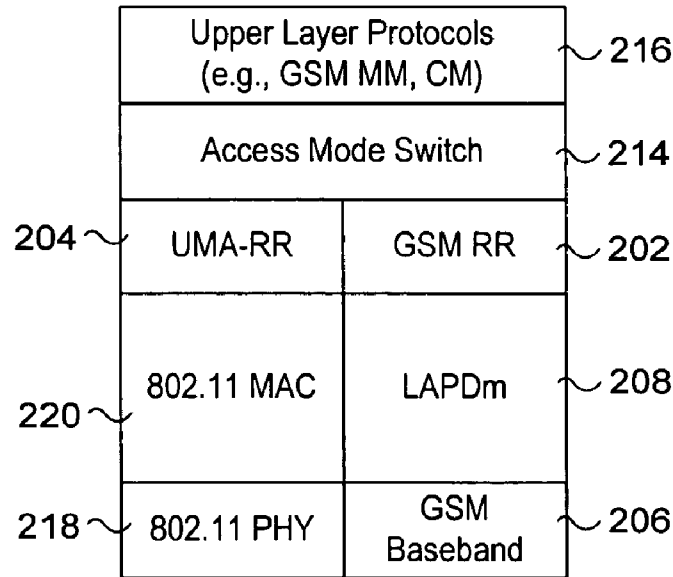

Fig. 2B

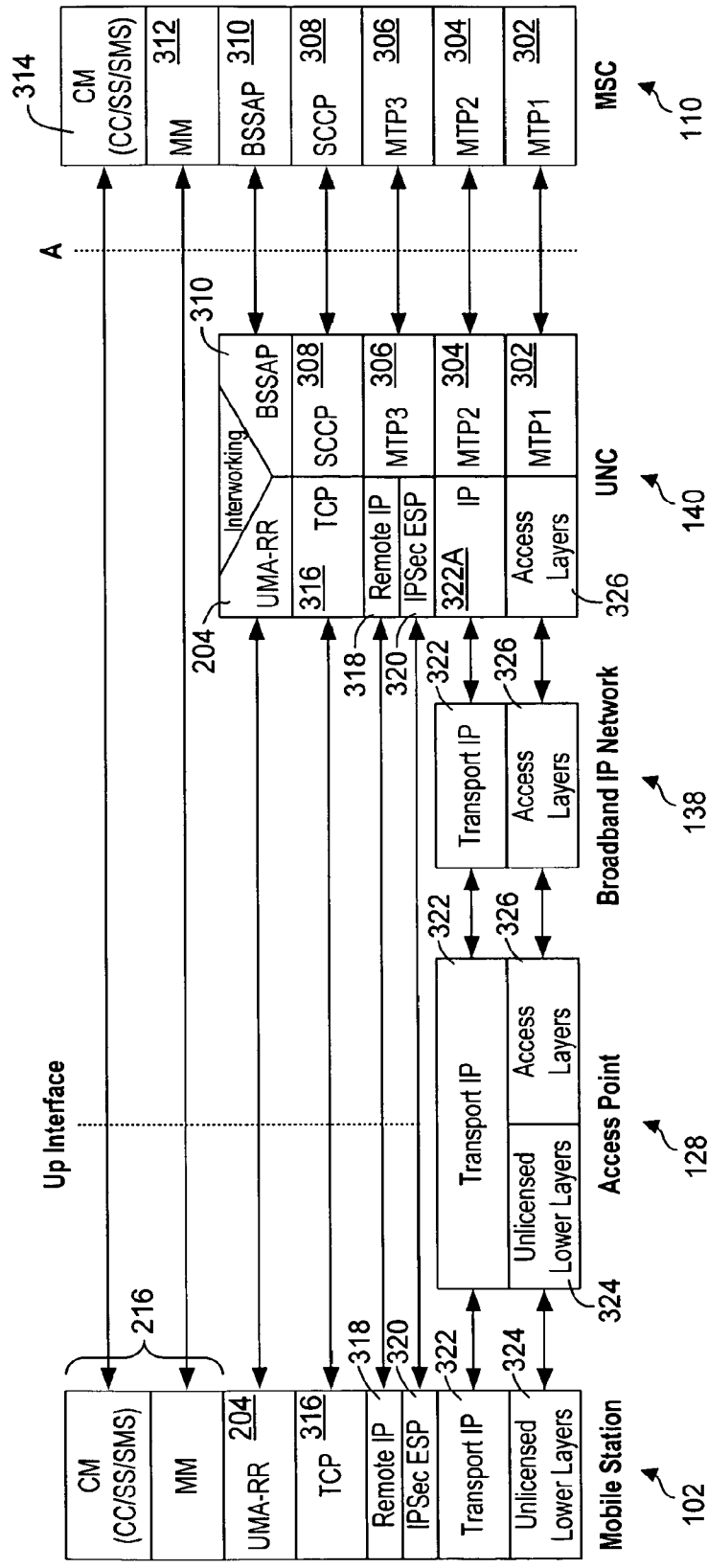

Fig. 3A

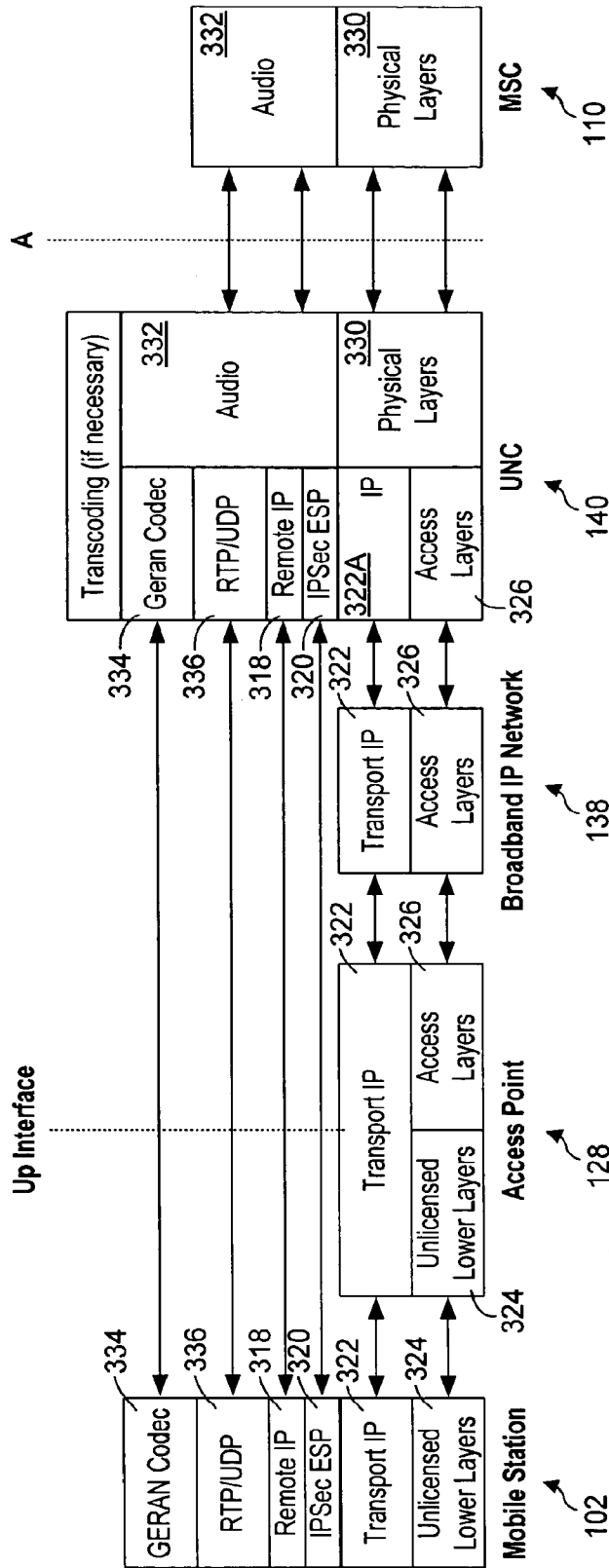

Fig. 3D

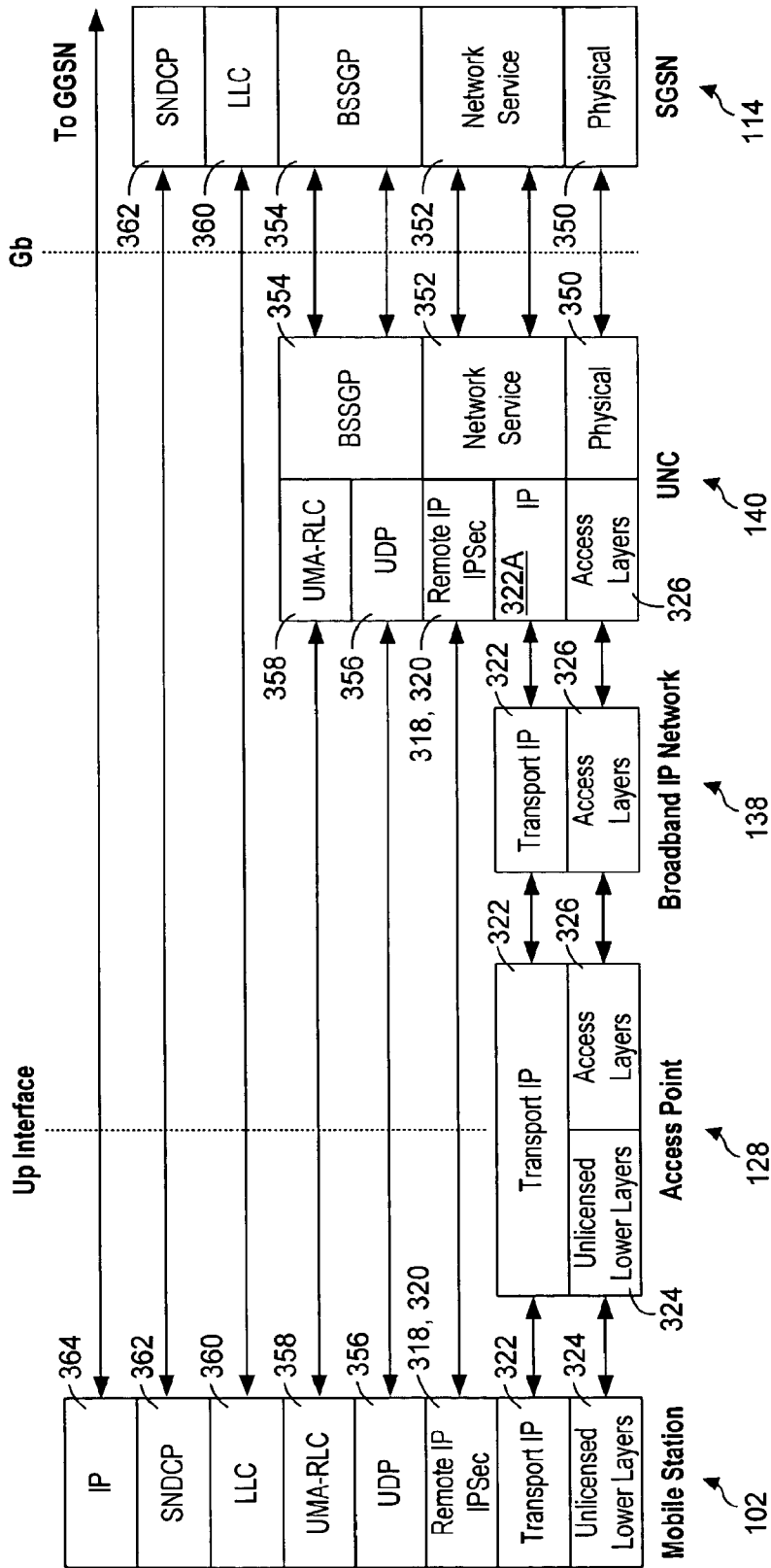

Fig. 3E

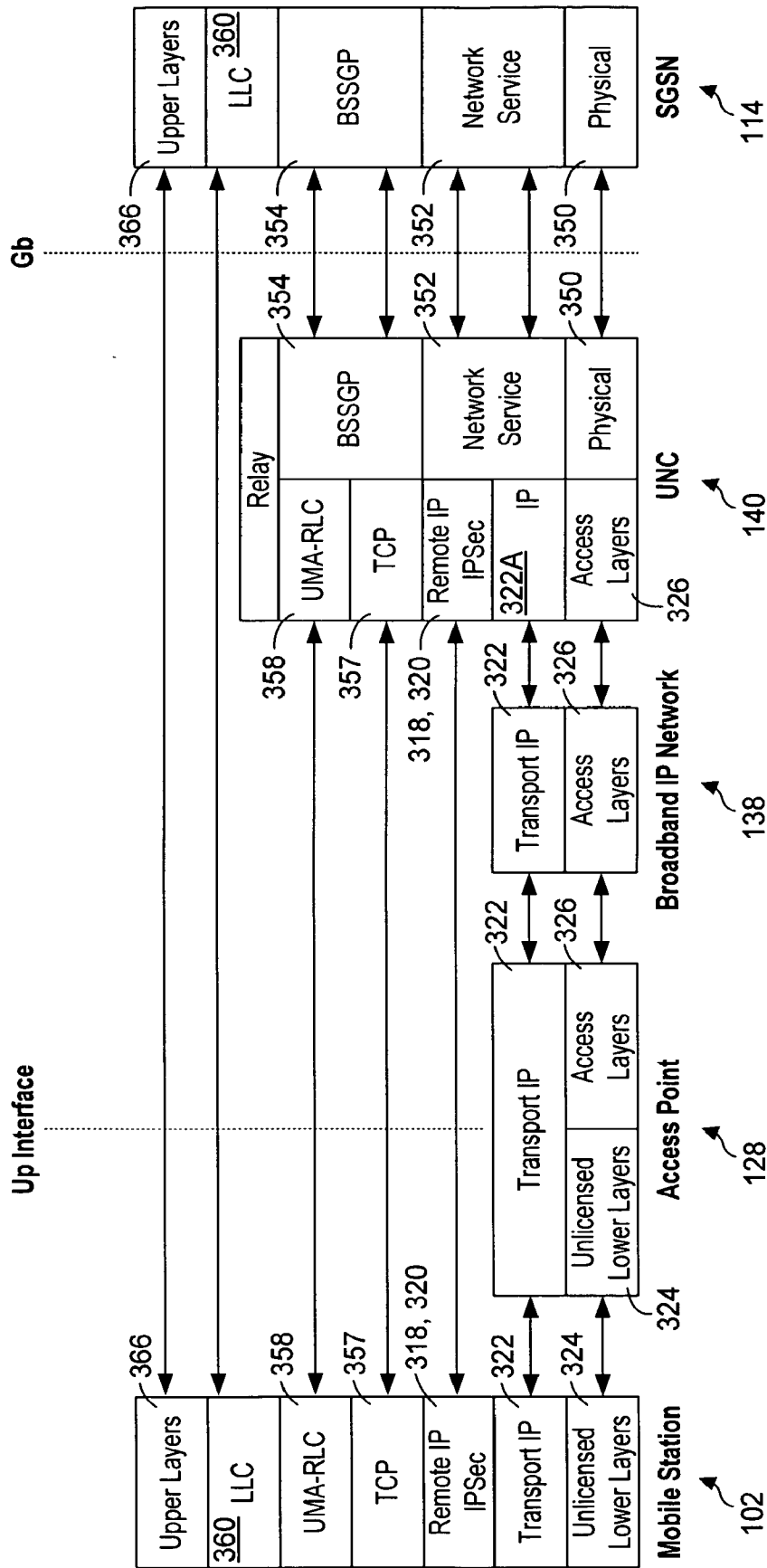

Fig. 3F

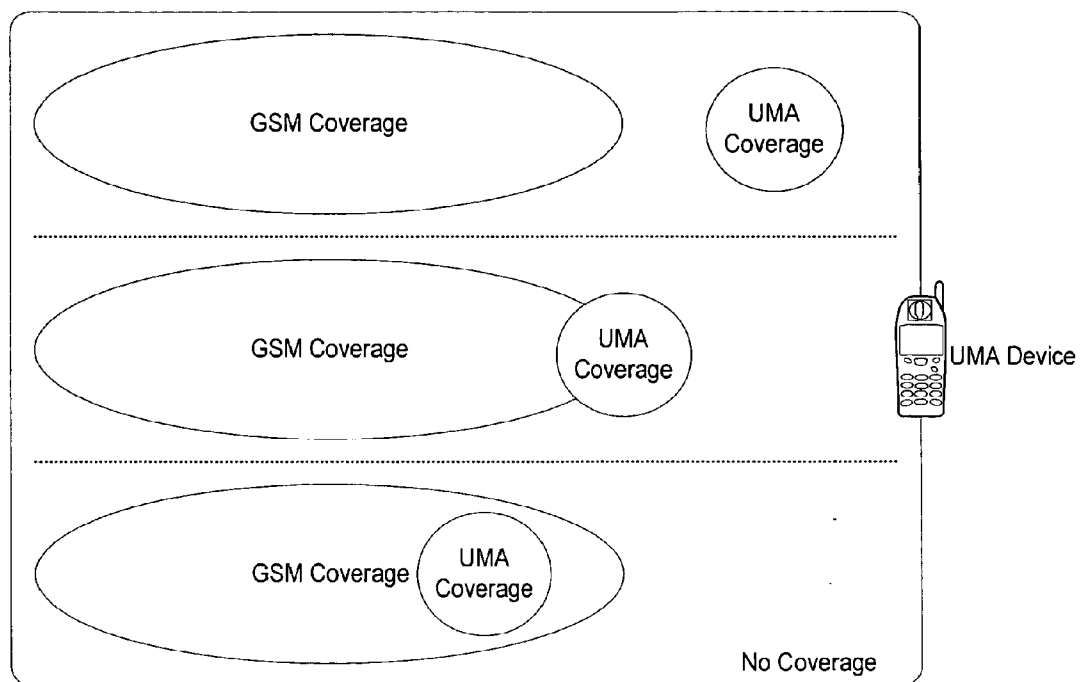

Fig. 4

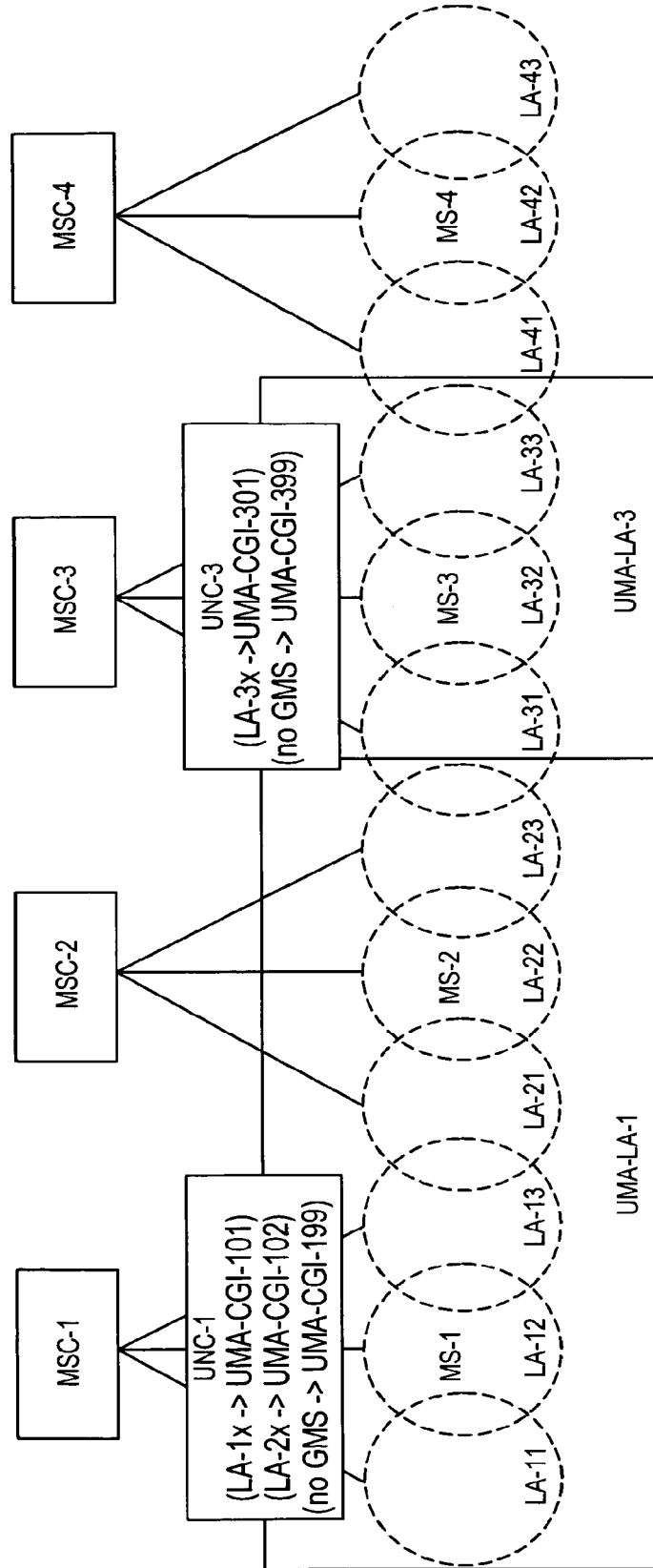
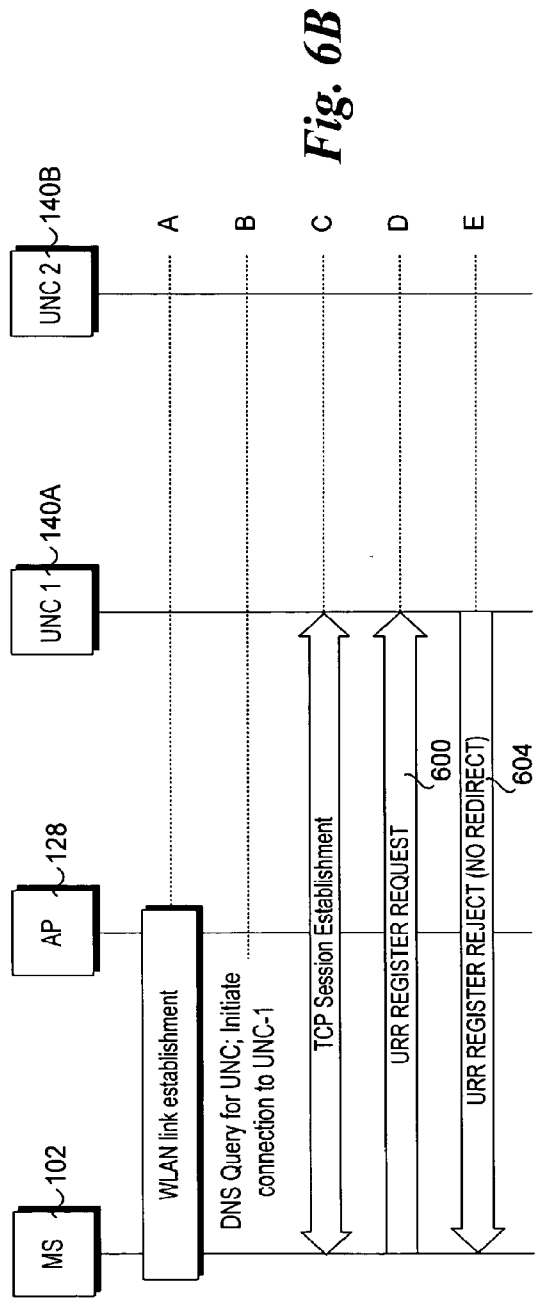
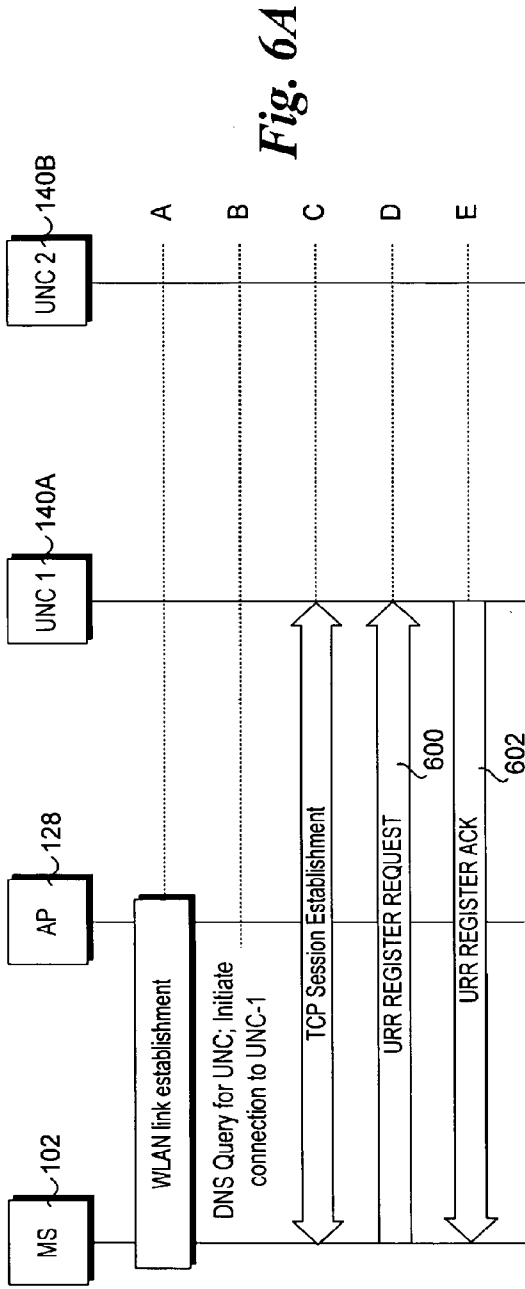

Fig. 5



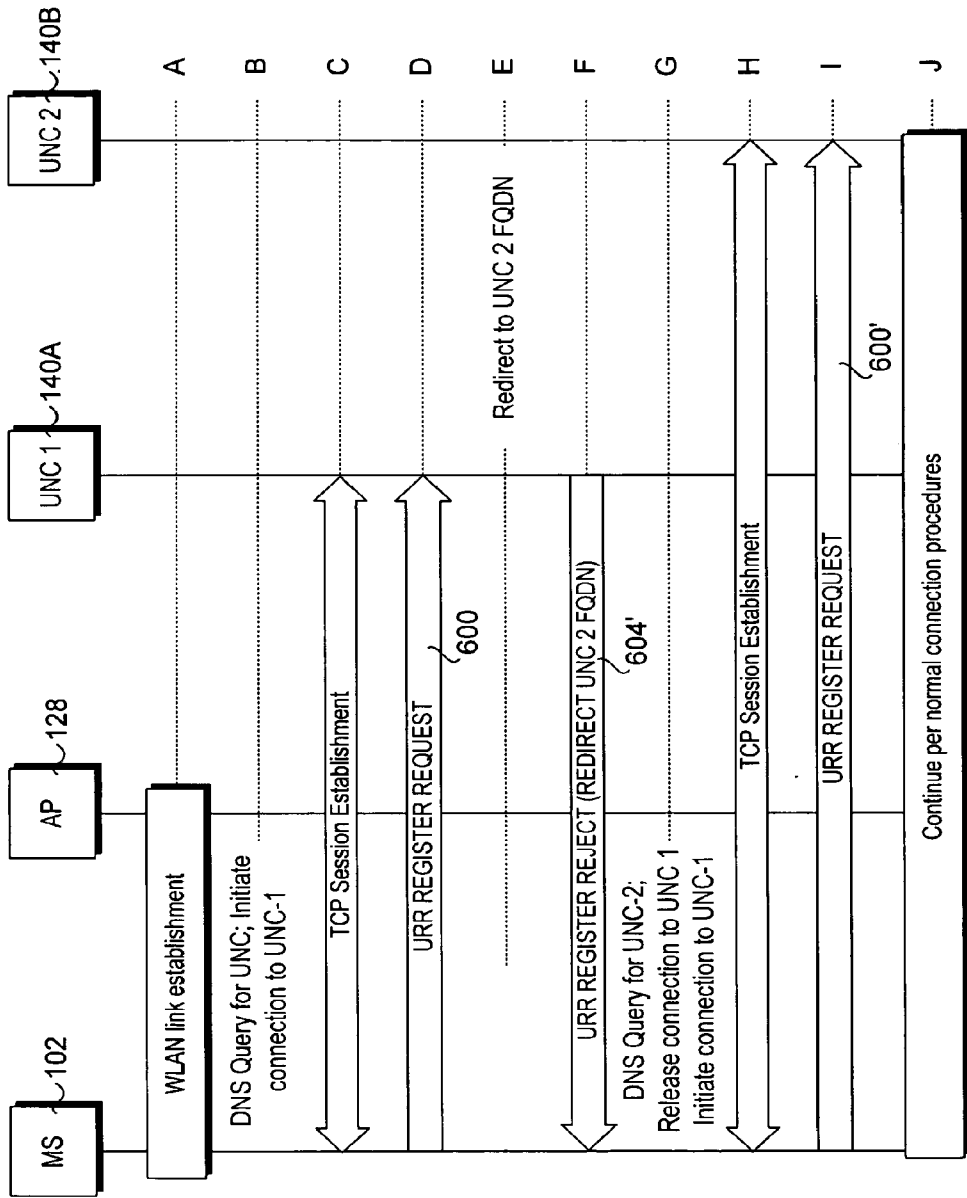

Fig. 6C

URR REGISTER REQUEST

Information Element	Type/Reference	Presence	Format	Length	Value
UMA RR Protocol Discriminator	Protocol Discriminator	M	V	½	0110
Skip Indicator	Skip Indicator	M	V	½	0000
URR REGISTER REQUEST Message Type	Message Type	M	V	1	0011 0011
UCI	UCI	M	V	1	0, 1 or 9
Mobile Identity	Mobile Identity	M	LV	9	10.5.1.4/GSM04.08
GSM RR state	GSM RR state	M	V	1	0 – Idle 1 - Dedicated
GPRS Class Capability	GPRS Class	M	V	1	0 – GSM only 1 – GPRS Class A 2 – GPRS Class B 3 – GPRS Class C
GPRS Downlink IP address	IP address	M	V	4	IP address
GPRS Downlink UDP port	Port	M	V	2	UDP port
Cell Identifier List (Preferred)	Cell Identifier List	O	TLV	7n+3 (0<n<8)	3.2.2.27/GSM08.08
C1 List	C1 List	C	TLV	n+2 (0<n<8)	C1 Range: [0,63]
AP Identifier	MAC address	C	TLV	6	MAC id of AP
AP Location	Location	O	TLV		Street address, lat, long

600B

Fig. 7A

URR REGISTER REQUEST

Information Element	Type/Reference	Presence	Format	Length	Value
Length Indicator	Length Indicator	M	V	2	
UMA RR Protocol Discriminator	Protocol Discriminator	M	V	½	0001
Skip Indicator	Skip Indicator	M	V	½	0000
URR REGISTER REQUEST Message Identity	Message Type	M	V	1	
Mobile Identity	Mobile Identity	M	LV	10	
UMA Release Indicator	UMA Release Indicator	M	V	1	
UMA Classmark	UMA Classmark	M	V	4	
AP Radio Identity	Radio Identity	C	TLV	9	
MS Radio Identity	Radio Identity	M	TLV	9	
GSM RR State	GSM RR State	M	TLV	3	
Coverage Indication	GSM Coverage Indication	M	TLV	3	
Cell Identity	Cell Identity	C	TLV	3	
Location Area Identification	Location Area Identification	C	TLV	7	
Routing Area Code	Routing Area Code	C	TLV	3	
Geographic Location	Geographic Location	O	TLV	9-n	
AP Location	AP Location	O	TLV	7 - n	
Register Reject Cause	Register Reject Cause	C	TLV	3	
Redirection Counter	Redirection Counter	C	TLV	3	
Last UNC SGW IP Address	IP Address	C	TLV	7-19	
Last UNC SGW FQDN	Fully Qualified Domain/Host Name	C	TLV	5-258	
Last UNC IP address	IP Address	C	TLV	7-19	
Last UNC FQDN	Fully Qualified Domain/Host Name	C	TLV	5-258	
AP Service Name	AP Service Name	C	TLV	4-67	
Registration Indicators	Registration Indicators	C	TLV	3	
UMA PLMN List	UMA PLMN List	C	TLV	n	

600B



Fig. 7B

Fig. 8A

URR REGISTER ACK

602A

Information Element	Type/Reference	Presence	Format	Length	Value
UMA RR Protocol Discriminator	Protocol Discriminator	M	V	½	0110
Skip Indicator	Skip Indicator	M	V	½	0000
URR REGISTER ACK Message Type	Message Type	M	V	1	0011 0110
UCI	UCI	M	V	1	0, 1 or 9
UMA System Information	UMA System Information	M	LV	16	
GPRS Uplink IP address	IP address	M	V	4	IP address
GPRS Uplink UDP port	Port	M	V	2	UDP port
Up Parameter Configuration	Up Parameter Configuration	O	TLV		
Status	Status	O	TLV	1	

Fig. 8B

UMA GSM SYSTEM INFORMATION

8	7	6	5	4	3	2	1
Length = 15							
UMA Cell Description encoded as V type IE as per §10.5.2.2 of GSM 04.08							
UMA Cell Description (continued)							
UMA Location Area Identification encoded as V type IE as per §10.5.1.3 of GSM 04.08							
UMA Location Area Identification (continued)							
UMA Location Area Identification (continued)							
UMA Location Area Identification (continued)							
UMA Location Area Identification (continued)							
UMA Cell Identity encoded as V type IE as per §10.5.1.1 of GSM 04.08							
UMA Cell Identity (continued)							
GLIR	ATT	TI 804			UMA-CELL-RESELECT-HYSTERESIS		
T 3212							
AC C15	AC C14	AC C13	AC C12	AC C11	EC C10	AC C09	AC C08
AC C07	AC C06	AC C05	AC C04	AC C03	EC C02	AC C01	AC C00
TI 811							
TI 900							
Spare 0	Spare 0	Spare 0	ECSM	UMA-BAND			
GPRS Ind	Spare 0	Spare 0	UMA-GPRS-CELL-RESELECT-HYSTERESIS			NMO	
UMA-RAC							

URR REGISTER ACCEPT

Information Element	Type/Reference	Presence	Format	Length	Value
Length Indicator	Length Indicator	M	V	2	
UMA RR Protocol Discriminator	Protocol Discriminator	M	V	½	0001
Skip Indicator	Skip Indicator	M	V	½	0000
URR REGISTER ACCEPT Message Identity	Message Type	M	V	1	
Cell Identity	Cell Identity	M	TLV	4	
Location Area Identification	Location Area Identification	M	TLV	7	
UNC Control Channel Description	UNC Control Channel Description	M	TLV	8	
TU3910 Timer	TU3910 Timer	M	TLV	4	
TU3906 Timer	TU3906 Timer	M	TLV	4	
UMA Band	UMA Band	M	TLV	3	
TU3920 Timer	TU3920 Timer	M	TLV	4	
UNC Cell Description	UMA Cell Description	O	TLV	4	
TU4001 Timer	TU4001 Timer	M	TLV	4	
TU4003 Timer	TU4003 Timer	C	TLV	4	
Location Status	Location Status	O	TLV	3	
UMA Service Zone Information	UMA Service Zone Information	O	TLV	5-36	

Fig. 8C

602C

URR REGISTER REJECT/REDIRECT

Information Element	Type/Reference	Presence	Format	Length	Value
UMA RR Protocol Discriminator	Protocol Discriminator	M	V	½	0110
Skip Indicator	Skip Indicator	M	V	½	0000
URR REGISTER REJ Message Type	Message Type	M	V	1	0011 0111
UCI	UCI	M	V	1	0, 1 or 9
UMA RR Cause	UMA RR Cause	M	V	1	
Redirected UNC Address	FQDN or IP address	O	LV		
Redirected SGW Address	FQDN or IP address	O	LV		

Fig. 9A

604A

URR REGISTER REJECT

Information Element	Type/Reference	Presence	Format	Length	Value
Length Indicator	Length Indicator	M	V	2	
UMA RR Protocol Discriminator	Protocol Discriminator	M	V	½	0001
Skip Indicator	Skip Indicator	M	V	½	0000
URR REGISTER REJECT Message Identity	Message Type	M	V	1	
Register Reject Cause	Register Reject Cause	M	TLV	3	
TU3907 Timer	TU3907 Timer	C	TLV	4	
Location Black List Indicator	Location Black List Indicator	C	TLV	3	
Location Area Identification	Location Area Identification	C	TLV	7	

Fig. 9B

604B

URR REGISTER REDIRECT

Information Element	Type/Reference	Presence	Format	Length	Value
Length Indicator	Length Indicator	M	V	2	
UMA RR Protocol Discriminator	Protocol Discriminator	M	V	½	0001
Skip Indicator	Skip Indicator	M	V	½	0000
URR REGISTER REDIRECT Message Identity	Message Type	M	V	1	
Serving UNC SGW IP Address	IP Address	C	TLV	7-19	
Serving UNC SGW FQDN	Fully Qualified Domain/Host Name	C	TLV	5-258	
Serving UNC IP address	IP Address	C	TLV	7-19	
Serving UNC FQDN	Fully Qualified Domain/Host Name	C	TLV	5-258	
Serving UNC Port Number	Communication Port	O	TLV	4	
Serving UNC Table Indicator	Serving UNC Table Indicator	M	TLV	3	
UMA PLMN List	UMA PLMN List	C	TLV	n	

Fig. 9C

604C

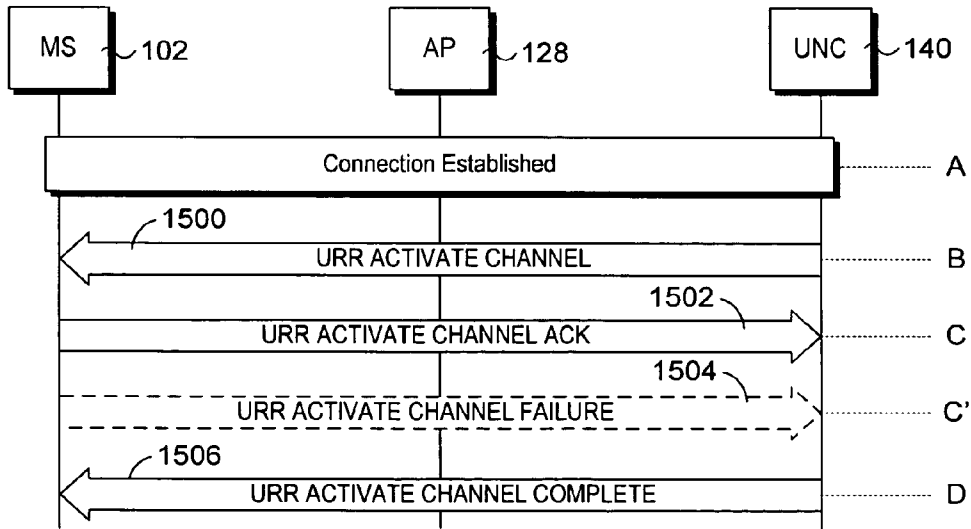

Fig. 15

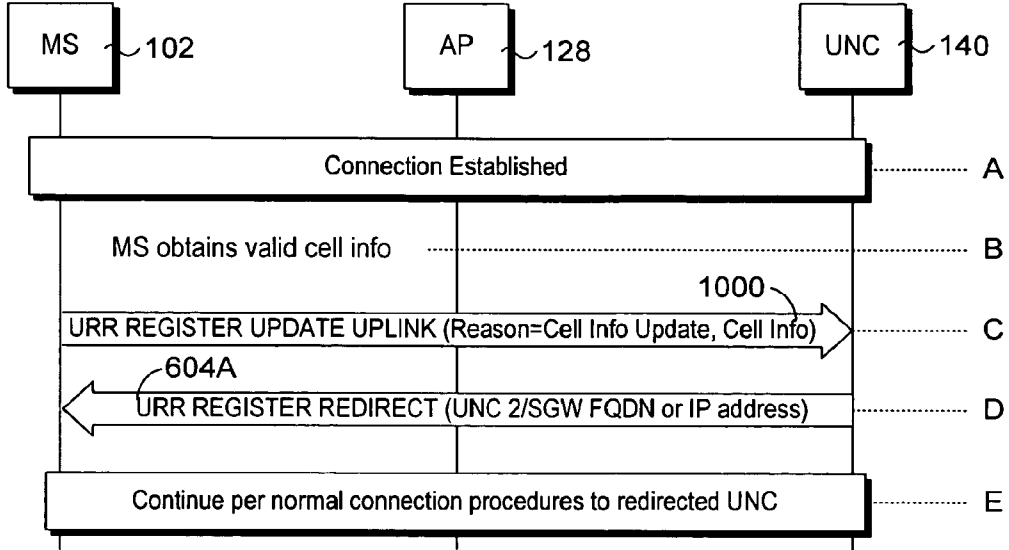

Fig. 10A

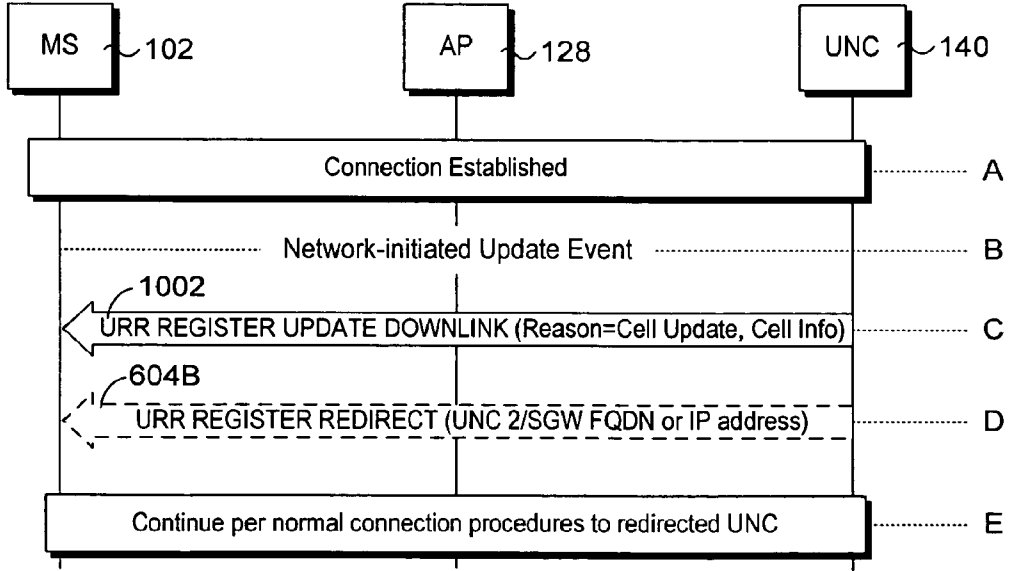

Fig. 10B

URR REGISTER UPDATE UPLINK

Information Element	Type/Reference	Presence	Format	Length	Value
UMA-RR Protocol Discriminator	Protocol Discriminator	M	V	½	0110
Skip Indicator	Skip Indicator	M	V	½	0000
URR REGISTER UPDATE UPLINK Message Type	Message Type	M	V	1	0011 1100
UCI	UCI	M	V	1	0, 1 or 9
Reason	Reason	M	V	1	0 Cell update 1 AP update
Cell Identifier List (Preferred)	Cell Identifier List	O	TLV	7n+3 (0<n<8)	3.2.2.27/GSM08.08
C1 List	C1 List	C	TLV	n+2 (0<n<8)	C1 Range: [0,63]
AP Identifier	MAC address	C	TLV	6	MAC id of AP
AP Location	Location	O	TLV		

Fig. 11A

1000A

URR REGISTER UPDATE UPLINK

Information Element	Type/Reference	Presence	Format	Length	Value
Length Indicator	Length Indicator	M	V	2	
UMA-RR Protocol Discriminator	Protocol Discriminator	M	V	½	0001
Skip Indicator	Skip Indicator	M	V	½	0000
URR REGISTER UPDATE UPLINK Message Identity	Message Type	M	V	1	
AP Radio Identity	Radio Identity	O	TLV	9	
Coverage Indication	Coverage Indication	O	TLV	3	
Cell Identity	Cell Identity	C	TLV	4	
Location Area Information	Location Area Information	C	TLV	7	
Routing Area Code	Routing Area Code	C	TLV	3	
Geographical Location	Geographical Location	O	TLV	9-n	
AP Location	AP Location	O	TLV		

Fig. 11B

1000B

URR REGISTER UPDATE DOWNLINK

Information Element	Type/Reference	Presence	Format	Length	Value
UMA RR Protocol Discriminator	Protocol Discriminator	M	V	½	0110
Skip Indicator	Skip Indicator	M	V	½	0000
URR REG UPDATE DOWNLINK Message Type	Message Type	M	V	1	0011 1101
UCI	UCI	M	V	1	0, 1 or 9
Redirected UNC Address	FQDN or IP address	O	LV		
Redirected SGW Address	FQDN or IP address	O	LV		
Status	Status	O	TLV		

Fig. 12A

1002A

URR REGISTER UPDATE DOWNLINK

Information Element	Type/Reference	Presence	Format	Length	Value
Length Indicator	Length Indicator	M	V	2	
UMA RR Protocol Discriminator	Protocol Discriminator	M	V	½	0001
Skip Indicator	Skip Indicator	M	V	½	0000
URR REGISTER UPDATE DOWNLINK Message Identity	Message Type	M	V	1	
Cell Identity	Cell Identity	M	TLV	4	
Location Area Identification	Location Area Identification	M	TLV	7	
UNC Control Channel Description	UNC Control Channel Description	M	TLV	8	
TU3910 Timer	TU3910 Timer	M	TLV	4	
TU3906 Timer	TU3906 Timer	M	TLV	4	
UMA Band	UMA Band	M	TLV	3	
TU3920 Timer	TU3920 Timer	M	TLV	4	
UNC Cell Description	UMA Cell Description	O	TLV	4	
TU4001 Timer	TU4001 Timer	M	TLV	4	
TU4003 Timer	TU4003 Timer	C	TLV	4	
Location Status	Location Status	O	TLV	3	

Fig. 12B

1002B

URR DEREGISTER

Information Element	Type/Reference	Presence	Format	Length	Value
UMA-RR Protocol Discriminator	Protocol Discriminator	M	V	½	0110
Skip Indicator	Skip Indicator	M	V	½	0000
URR DEREGISTER Message Type	Message type	M	V	1	0011 1011
URR Cause	URR Cause	M	V	1	
UCI	UCI	M	V	1	0, 1 or 9

Fig. 13A

1300A

URR DEREGISTER

Information Element	Type/Reference	Presence	Format	Length	Value
Length Indicator	Length Indicator	M	V	2	
UMA-RR Protocol Discriminator	Protocol Discriminator	M	V	½	0001
Skip Indicator	Skip Indicator	M	V	½	0000
URR DEREGISTER Message Identity	Message type	M	V	1	
Register Reject Cause	Register Reject Cause	M	TLV	3	
Location Black List Indicator	Location Black List Indicator	C	TLV	3	
Location Area Identification	Location Area Identification	C	TLV	7	

Fig. 13B

1300B

URR CAUSE VALUES

Bit								Decimal	Description
8	7	6	5	4	3	2	1		
0	0	0	0	0	0	0	0	0	Normal event
0	0	0	0	0	0	0	1	1	Abnormal release, unspecified
0	0	0	0	0	0	1	0	2	Abnormal release, channel unacceptable
0	0	0	0	0	0	1	1	3	Abnormal release, timer expired
0	0	0	0	0	1	0	0	4	Abnormal release, no activity on the radio path
0	0	0	0	0	1	0	1	5	Preemptive release
0	0	0	0	1	0	0	0	8	Handover impossible, timing advance out of range
0	0	0	0	1	0	0	1	9	Channel mode unacceptable
0	0	0	0	1	0	1	0	10	Frequency not implemented
0	1	0	0	0	0	0	1	65	Call already cleared
0	1	0	1	1	1	1	1	95	Semantically incorrect message
0	1	1	0	0	0	0	0	96	Invalid mandatory information
0	1	1	0	0	0	0	1	97	Message type non-existent or not implemented
0	1	1	0	0	0	1	0	98	Message type not compatible with protocol state
0	1	1	0	0	1	0	0	100	Conditional IE error
0	1	1	0	0	1	0	1	101	No cell allocation available
0	1	1	0	1	1	1	1	111	Protocol error unspecified
1	0	0	0	1	1	0	0	140	Unauthorized subscriber
1	0	0	0	1	1	0	1	141	Radio channel bearer failure
1	0	0	0	1	1	1	0	142	GSM RR busy
1	0	0	0	1	1	1	1	143	T1811 timeout
1	0	0	1	0	0	0	0	144	Link detach
1	0	0	1	0	0	0	1	145	T1900 timeout
1	0	0	1	0	0	1	0	146	Signaling CHANNEL FAILURE
1	0	0	1	0	0	1	1	147	MS is not attached
1	0	0	1	0	1	0	0	148	Loss of radio connection
1	0	0	1	0	1	0	1	149	Radio channel assignment failure
1	0	0	1	0	1	1	0	150	VoIP channel establishment failure

Fig. 14

URR ACTIVATE CHANNEL

Information Element	Type/Reference	Presence	Format	Length	Value
UMA RR Protocol Discriminator	Protocol Discriminator	M	V	½	0110
Skip Indicator	Skip Indicator	M	V	½	0000
URR ACTIVATE CHANNEL Message Type	Message type	M	V	1	0010 1110
UCI	UCI	M	V	1	0, 1 or 9
Channel Mode	Channel Mode	M	V	1	10.5.2.6/GSM04.08
UNC SDP	SDP	M	LV		Per RFC 2327, RFC 3551 and RFC 3267
CIPHER Mode Setting	CIPHER Mode Setting	O	TV	1	10.5.2.9/GSM04.08

Fig. 16A

1500A

URR ACTIVATE CHANNEL

Information Element	Type/Reference	Presence	Format	Length	Value
Length Indicator	Length Indicator	M	V	2	
UMA RR Protocol Discriminator	Protocol Discriminator	M	V	½	0001
Skip Indicator	Skip Indicator	M	V	½	0000
URR ACTIVATE CHANNEL Message Identity	Message type	M	V	1	
Channel Mode	Channel Mode	M	TLV	3	
Sample Size	Sample Size	M	TLV	3	CS payload sample size in ms
IP Address	IP Address	M	TLV	7-19	
RDP UDP Port	Communication Port	M	TLV	4	
Payload Type	Payload Type	O	TLV	3	
Multi-rate Configuration	Multi-rate Configuration	C	TLV	3-n	
RTP Redundancy Configuration	RTP Redundancy Configuration	C	TLV	3-6	
RTCP UDP Port	Communication Port	O	TLV	4	

Fig. 16B

1500B

URR ACTIVATE CHANNEL ACK

Information Element	Type/Reference	Presence	Format	Length	Value
UMA RR Protocol Discriminator	Protocol Discriminator	M	V	½	0110
Skip Indicator	Skip Indicator	M	V	½	0000
URR ACTIVATE CHANNEL Ack Message Type	Message type	M	V	1	0010 1001
UCI	UCI	M	V	1	0, 1 or 9
MS SDP	SDP	M	LV		Per RFC 2327, RFC 3551 and RFC 3267
Cell Identifier List (Preferred)	Cell Identifier List	O	TLV	7n+3 (0<n<8)	3.2.2.27/GSM08.08
C1 List	C1 List	C	TLV	n+2 (0<n<8)	C1 Range: [0,63]

Fig. 17A

1502A

URR ACTIVATE CHANNEL ACK

Information Element	Type/Reference	Presence	Format	Length	Value
Length Indicator	Length Indicator	M	V	2	
UMA RR Protocol Discriminator	Protocol Discriminator	M	V	½	0001
Skip Indicator	Skip Indicator	M	V	½	0000
URR ACTIVATE CHANNEL Ack Message Identity	Message type	M	V	1	
RTP UDP Port	Communication Port	M	TLV	4	
Sample Size	Sample Size	M	TLV	3	CS payload sample size in ms
Payload Type	Payload Type	O	TLV	3	
RTCP UDP Port	Communication Port	O	TLV	4	

Fig. 17B

1502B

URR ACTIVATE CHANNEL FAILURE

Information Element	Type/Reference	Presence	Format	Length	Value
UMA RR Protocol Discriminator	Protocol Discriminator	M	V	½	0110
Skip Indicator	Skip Indicator	M	V	½	0000
URR ACTIVATE CHANNEL FAILURE Message Type	Message type	M	V	1	0010 1111
UCI	UCI	M	V	1	0, 1 or 9
UMA RR Cause	UMA RR Cause	M	V	1	
Cell Identifier List (Preferred)	Cell Identifier List	O	TLV	7n+3 (0<n<8)	3.2.2.27/GSM08.08
C1 List	C1 List	C	TLV	n+2 (0<n<8)	C1 Range: [0,63]

Fig. 18A

1504A

URR ACTIVATE CHANNEL FAILURE

Information Element	Type/Reference	Presence	Format	Length	Value
Length Indicator	Length Indicator	M	V	2	
UMA RR Protocol Discriminator	Protocol Discriminator	M	V	½	0001
Skip Indicator	Skip Indicator	M	V	½	0000
URR ACTIVATE CHANNEL FAILURE Message Identity	Message type	M	V	1	
UMA RR Cause	UMA RR Cause	M	TLV	3	

Fig. 18B

1504B

URR ACTIVATE CHANNEL COMPLETE

Information Element	Type/Reference	Presence	Format	Length	Value
UMA RR Protocol Discriminator	Protocol Discriminator	M	V	1/2	0110
Skip Indicator	Skip Indicator	M	V	1/2	0000
URR ACTIVATE CHANNEL COMPLETE Message Type	Message type	M	V	1	0010 1010
UCI	UCI	M	V	1	0, 1 or 9

Fig. 19A

1506A

URR ACTIVATE CHANNEL COMPLETE

Information Element	Type/Reference	Presence	Format	Length	Value
Length Indicator	Length Indicator	M	V	2	
UMA RR Protocol Discriminator	Protocol Discriminator	M	V	1/2	0001
Skip Indicator	Skip Indicator	M	V	1/2	0000
URR ACTIVATE CHANNEL COMPLETE Message Identity	Message type	M	V	1	

Fig. 19B

1506B

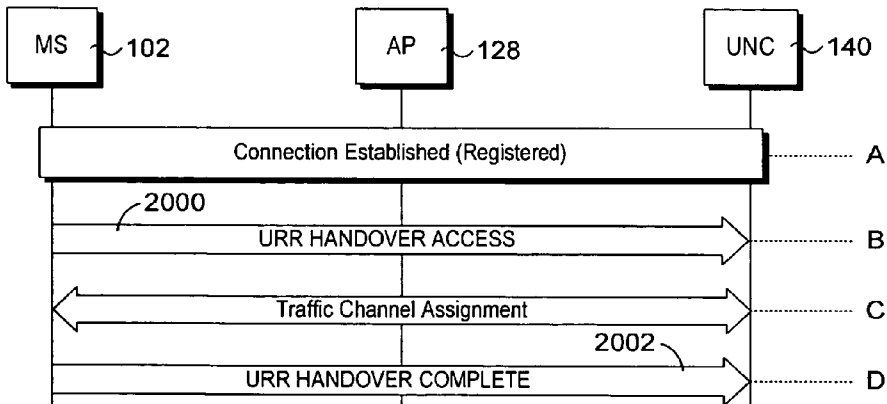

Fig. 20

URR HANDOVER ACCESS

Information Element	Type/Reference	Presence	Format	Length	Value
UMA RR Protocol Discriminator	Protocol Discriminator	M	V	½	0110
Skip Indicator	Skip Indicator	M	V	½	0000
URR HANDOVER ACCESS Message Type	Message type	M	V	1	0010 1101
UCI	UCI	M	V	½	1 or 9
HANDOVER COMMAND message	HANDOVER COMMAND layer 3 message	M	V	variable	9.1.15/GSM04.08

Fig. 21A

2000A

URR HANDOVER ACCESS

Information Element	Type/Reference	Presence	Format	Length	Value
Length Indicator	Length Indicator	M	V	2	
UMA RR Protocol Discriminator	Protocol Discriminator	M	V	½	0001
Skip Indicator	Skip Indicator	M	V	½	0000
URR HANDOVER ACCESS Message Identity	Message type	M	V	1	
Handover to UMAN Command	L3 Message	M	TLV	variable	

Fig. 21B

2000B

URR HANDOVER COMPLETE

Information Element	Type/Reference	Presence	Format	Length	Value
UMA RR Protocol Discriminator	Protocol Discriminator	M	V	½	0110
Skip Indicator	Skip Indicator	M	V	½	0000
UMA HANDOVER COMPLETE Message Type	Message type	M	V	1	0010 1100
UCI	UCI	M	V	1	0, 1 or 9

Fig. 22A

2002A

URR HANDOVER COMPLETE

Information Element	Type/Reference	Presence	Format	Length	Value
Length Indicator	Length Indicator	M	V	2	
UMA RR Protocol Discriminator	Protocol Discriminator	M	V	½	0110
Skip Indicator	Skip Indicator	M	V	½	0000
UMA HANDOVER COMPLETE Message Identity	Message type	M	V	1	0010 1100

Fig. 22B

2002B

URR UPLINK QUALITY INDICATION

Information Element	Type/Reference	Presence	Format	Length	Value
Length Indication	Length Indication	M	V	2	
UMA RR Protocol Discriminator	Protocol Discriminator	M	V	½	0001
Skip Indicator	Skip Indicator	M	V	½	0000
URR UPLINK QUALITY IND Message Type	Message Type	M	V	1	
UL Quality Indication	UL Quality Indication	M	V	3	

Fig. 24

2300

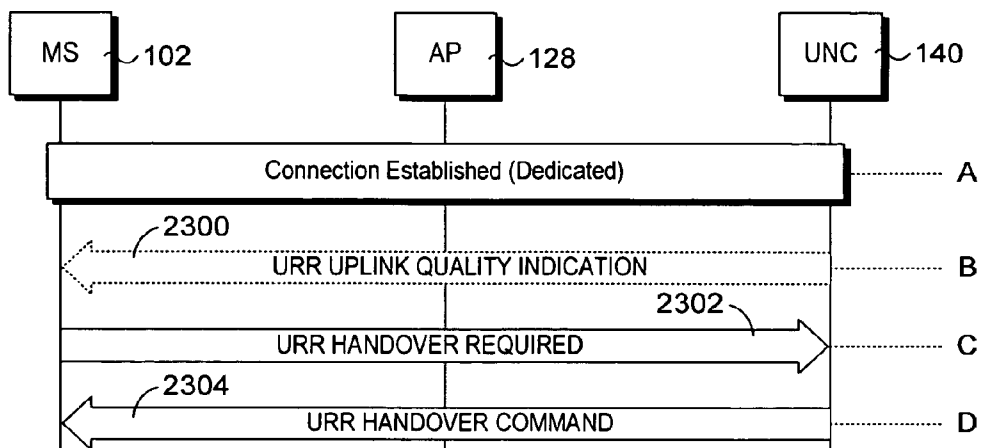

Fig. 23A

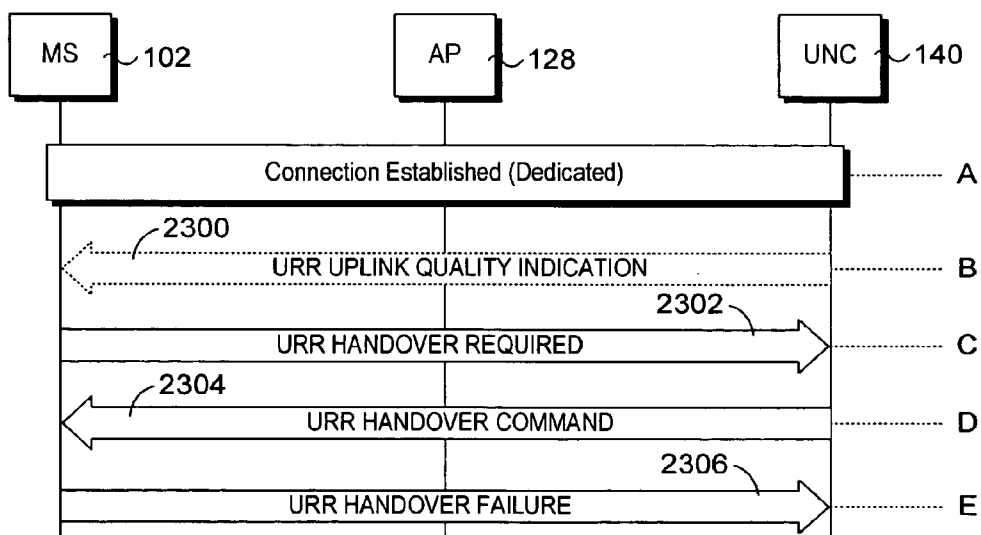

Fig. 23B

URR HANDOVER REQUIRED

Information Element	Type/Reference	Presence	Format	Length	Value
UMA RR Protocol Discriminator	Protocol Discriminator	M	V	½	0110
Skip Indicator	Skip Indicator	M	V	½	0000
URR HANDOVER REQUIRED Message Type	Message type	M	V	1	0001 0001
UCI	UCI	M	V	1	0, 1 or 9
Channel Mode	Channel Mode	M	V	1	10.5.2.6/GSM04.08
Cell Identifier List (Preferred)	Cell Identifier List	M	LV	7n+2 (0<n<8)	3.2.2.27/GSM08.08
C1 List	C1 List	M	LV	n+1 (0<n<8)	C1 Range: [0,63]

Fig. 25A

2302A

URR HANDOVER REQUIRED

Information Element	Type/Reference	Presence	Format	Length	Value
Length Indicator	Length Indicator	M	V	2	
UMA RR Protocol Discriminator	Protocol Discriminator	M	V	½	0001
Skip Indicator	Skip Indicator	M	V	½	0000
URR HANDOVER REQUIRED Message Identity	Message type	M	V	1	
GERAN Cell Identifier List	Cell Identifier List	C	TLV	n	
GERAN Received Signal Level List	Received Signal Level List	C	TLV	n	
UTRAN Cell Identifier List	UTRAN Cell Identifier List	C	TLV	n	
UTRAN Received Signal Level List	Received Signal Level List	C	TLV	n	

Fig. 25B

2302B

URR HANDOVER COMMAND

Information Element	Type/Reference	Presence	Format	Length	Value
UMA RR Protocol Discriminator	Protocol Discriminator	M	V	½	0110
Skip Indicator	Skip Indicator	M	V	½	0000
URR HANDOVER COMMAND Message Type	Message type	M	V	1	0010 1011
UCI	UCI	M	V	1	0, 1 or 9
Cell Description	Cell Description	M	V	2	10.5.2.2/GSM04.08
Description of the first channel, after time	Channel Description 2	M	V	3	10.5.2.5a/GSM04.08
Handover Reference	Handover Reference	M	V	1	10.5.2.15/GSM04.08
Power Command and Access type	Power command and access type	M	V	1	10.5.2.28a/GSM04.08
Synchronization indication	Synchronization indication	O	TV	1	10.5.2.39/GSM04.08
Frequency Short List, after time	Frequency Short List	C	TV	10	10.5.2.14/GSM04.08
Frequency List, after time	Frequency List	C	TLV	4-131	10.5.2.13/GSM04.08
Cell Channel Description	Cell Channel Description	C	TV	17	10.5.2.1b/GSM04.08
Mode of the First Channel	Channel Mode	O	TV	2	10.5.2.6/GSM04.08
Frequency Channel Sequence, after time	Frequency Channel Sequence	C	TV	10	10.5.2.12/GSM04.08
Mobile Allocation, after time	Mobile Allocation	C	TLV	3-10	10.5.2.21/GSM04.08
Starting Time	Starting Time	O	TV	3	10.5.2.38/GSM04.08
Timing Advance	Timing Advance	C	TV	2	10.5.2.40/GSM04.08
Frequency Short List, before time	Frequency Short List	C	TV	10	10.5.2.14/GSM04.08
Frequency List, before time	Frequency List	C	TLV	4-131	10.5.2.13/GSM04.08
Description of the first channel, before time	Channel Description 2	O	TV	4	10.5.2.5a/GSM04.08

Fig. 26A

2304A

URR HANDOVER COMMAND (Continued)

Information Element	Type/Reference	Presence	Format	Length	Value
Frequency Channel Sequence, after time	Frequency Channel Sequence	C	TV	10	10.5.2.12/GSM04.08
Mobile Allocation, after time	Mobile Allocation	C	TLV	3-10	10.5.2.21/GSM04.08
Starting Time	Starting Time	O	TV	3	10.5.2.38/GSM04.08
Timing Advance	Timing Advance	C	TV	2	10.5.2.40/GSM04.08
Frequency Short List, before time	Frequency Short List	C	TV	10	10.5.2.14/GSM04.08
Frequency List, before time	Frequency List	C	TLV	4-131	10.5.2.13/GSM04.08
Description of the first channel, before time	Channel Description 2	O	TV	4	10.5.2.5a/GSM04.08
Frequency Channel Sequence, before time	Frequency Channel Sequence	C	TV	10	10.5.2.12/GSM04.08
Mobile Allocation, before time	Mobile Allocation	C	TLV	3-10	10.5.2.21/GSM04.08
CIPHER Mode Setting	CIPHER Mode Setting	O	TV	1	10.5.2.9/GSM04.08
Multi-rate Configuration	Multi-rate Configuration	O	TLV	4-8	10.5.2.21aa/GSM04.08

Fig. 26B

2304A

URR HANDOVER COMMAND

Information Element	Type/Reference	Presence	Format	Length	Value
Length Indicator	Length Indicator	M	V	2	
UMA RR Protocol Discriminator	Protocol Discriminator	M	V	½	0001
Skip Indicator	Skip Indicator	M	V	½	0000
URR HANDOVER COMMAND Message Indicator	Message type	M	V	1	
Handover From UMAN Command	Handover From UMAN Command	M	TLV	n	

Fig. 26C

2304B

URR HANDOVER FAILURE

Information Element	Type/Reference	Presence	Format	Length	Value
UMA RR Protocol Discriminator	Protocol Discriminator	M	V	½	0110
Skip Indicator	Skip Indicator	M	V	½	0000
URR HANDOVER FAILURE Message Type	Message type	M	V	1	0010 1000
UCI	UCI	M	V	1	0, 1 or 9
UMA RR Cause	UMA RR Cause	M	V	1	

Fig. 27A

2406A

URR HANDOVER FAILURE

Information Element	Type/Reference	Presence	Format	Length	Value
Length Indicator	Length Indicator	M	V	2	
UMA RR Protocol Discriminator	Protocol Discriminator	M	V	½	0001
Skip Indicator	Skip Indicator	M	V	½	0000
URR HANDOVER FAILURE Message Identity	Message type	M	V	1	
RR Cause	RR Cause	M	TLV	3	

Fig. 27B

2406B

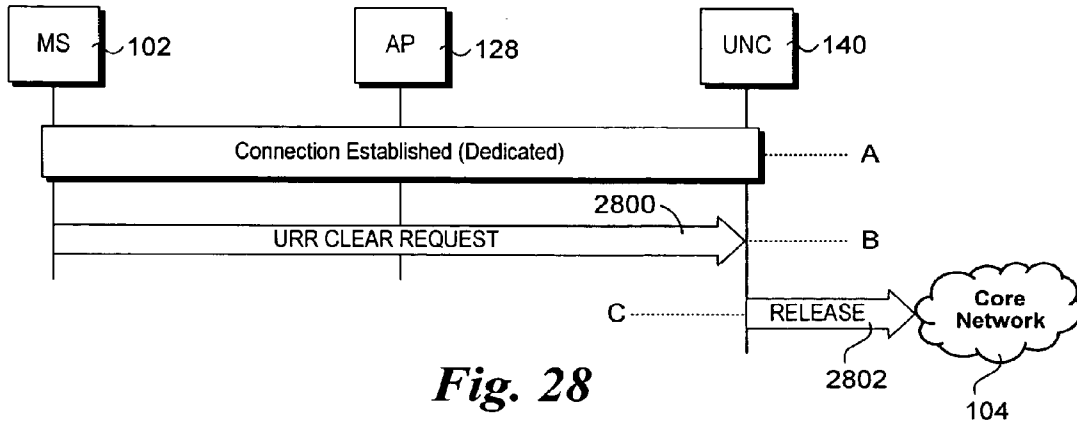

Fig. 28

104

URR RR CLEAR REQUEST

Information Element	Type/Reference	Presence	Format	Length	Value
UMA RR Protocol Discriminator	Protocol Discriminator	M	V	½	0110
Skip Indicator	Skip Indicator	M	V	½	0000
URR RR CLEAR REQUEST Message Type	Message type	M	V	1	0011 1111
UCI	UCI	M	V	1	0, 1 or 9

Fig. 29A

2800A

URR CLEAR REQUEST

Information Element	Type/Reference	Presence	Format	Length	Value
Length Indicator	Length Indicator	M	V	2	
UMA RR Protocol Discriminator	Protocol Discriminator	M	V	½	0001
Skip Indicator	Skip Indicator	M	V	½	0000
URR RR CLEAR REQUEST Message Type	Message type	M	V	1	
RR Cause	RR Cause	M	TLV	3	

Fig. 29B

2800B

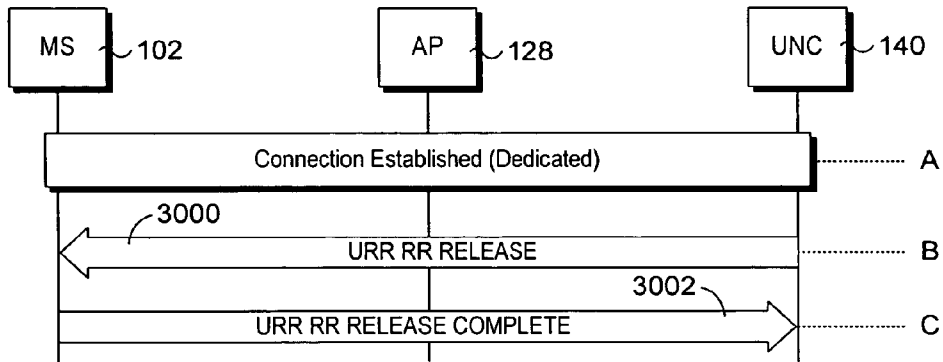

Fig. 30

URR RR RELEASE

Information Element	Type/Reference	Presence	Format	Length	Value
UMA RR Protocol Discriminator	Protocol Discriminator	M	V	½	0110
Skip Indicator	Skip Indicator	M	V	½	0000
URR RR RELEASE Message Type	Message type	M	V	1	0000 1101
UCI	UCI	M	V	1	0, 1 or 9
UMA RR Cause	UMA RR Cause	M	V	1	
GPRS Resumption	GPRS Resumption	O	TV	1	10.5.2.14c/GSM04.08

Fig. 31A

3000A

URR RELEASE

Information Element	Type/Reference	Presence	Format	Length	Value
Length Indicator	Length Indicator	M	V	2	
UMA RR Protocol Discriminator	Protocol Discriminator	M	V	½	0001
Skip Indicator	Skip Indicator	M	V	½	0000
URR RR RELEASE Message Identity	Message type	M	V	1	
UMA RR Cause	UMA RR Cause	M	V	1	
GPRS Resumption	GPRS Resumption	O	TV	1	

Fig. 31B

3000B

URR RR RELEASE COMPLETE

Information Element	Type/Reference	Presence	Format	Length	Value
UMA RR Protocol Discriminator	Protocol Discriminator	M	V	½	0110
Skip Indicator	Skip Indicator	M	V	½	0000
URR RR RELEASE COMPLETE Message Type	Message type	M	V	1	0000 1111
UCI	UCI	M	V	1	0, 1 or 9

Fig. 32A

3002A

URR RELEASE COMPLETE

Information Element	Type/Reference	Presence	Format	Length	Value
Length Indicator	Length Indicator	M	V	2	
UMA RR Protocol Discriminator	Protocol Discriminator	M	V	½	0001
Skip Indicator	Skip Indicator	M	V	½	0000
URR RELEASE COMPLETE Message Identity	Message type	M	V	1	

Fig. 32B

3002B

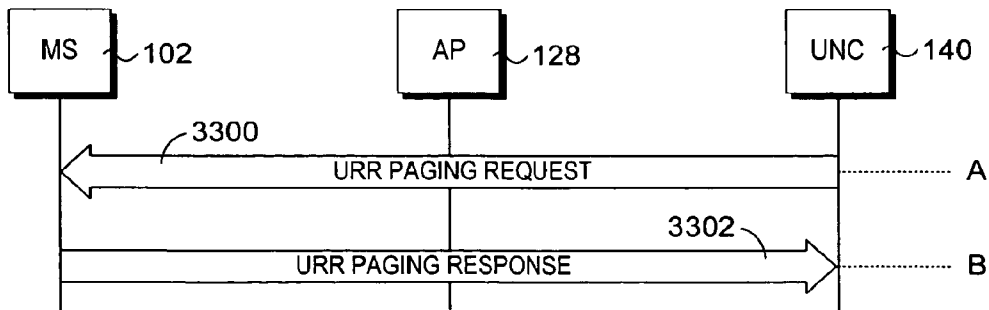

Fig. 33

URR PAGING REQUEST

Information Element	Type/Reference	Presence	Format	Length	Value
UMA RR Protocol Discriminator	Protocol Discriminator	M	V	½	0110
Skip Indicator	Skip Indicator	M	V	½	0000
URR PAGING REQUEST Message Type	Message type	M	V	1	0010 0001
UCI	UCI	M	V	1	0, 1 or 9
Spare Half Octet	Spare Half Octet	M	V	½	10.5.1.8/GSM04.08
Channel Needed	Channel Needed	M	V	½	10.5.2.8/GSM04.08
Mobile Identity	Mobile Identity	M	LV	2-9	10.5.1.4/GSM04.08

Fig. 34A

3300A

URR PAGING REQUEST

Information Element	Type/Reference	Presence	Format	Length	Value
Length Indicator	Length Indicator	M	V	2	
UMA RR Protocol Discriminator	Protocol Discriminator	M	V	½	0001
Skip Indicator	Skip Indicator	M	V	½	0000
URR PAGING REQUEST Message Identity	Message type	M	V	1	
Channel Needed	Channel Needed	M	TLV	3	
Mobile Identity	Mobile Identity	M	TLV	7-10	

Fig. 34B

3300B

URR PAGING RESPONSE

Information Element	Type/Reference	Presence	Format	Length	Value
UMA RR Protocol Discriminator	Protocol Discriminator	M	V	½	0110
Skip Indicator	Skip Indicator	M	V	½	0000
URR PAGING RESPONSE Message Type	Message type	M	V	1	0010 0111
UCI	UCI	M	V	1	0, 1 or 9
Ciphering Key Sequence Number	Ciphering Key Sequence Number	M	V	½	10.5.1.2/GSM04.08
Spare Half Octet	Spare Half Octet	M	V	½	10.5.1.8/GSM04.08
Mobile Station Classmark	Mobile Station Classmark 2	M	LV	4	10.5.1.6/GSM04.08
Mobile Identity	Mobile Identity	M	LV	2-9	10.5.1.4/GSM04.08

Fig. 35A

3302A

URR PAGING RESPONSE

Information Element	Type/Reference	Presence	Format	Length	Value
Length Indicator	Length Indicator	M	V	2	
UMA RR Protocol Discriminator	Protocol Discriminator	M	V	½	0001
Skip Indicator	Skip Indicator	M	V	½	0000
URR PAGING RESPONSE Message Identity	Message type	M	V	1	
Ciphering Key Sequence Number	Ciphering Key Sequence Number	M	V	3	
Mobile Station Classmark 2	Mobile Station Classmark 2	M	TLV	5	
Mobile Identity	Mobile Identity	M	TLV	7-10	
Establishment Cause	Establishment Cause	M	TLV	3	

Fig. 35B

3302B

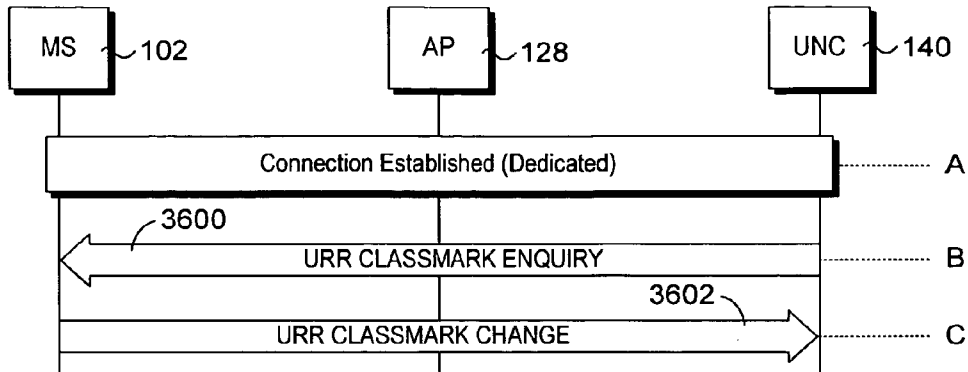

Fig. 36

URR CLASSMARK ENQUIRY

Information Element	Type/Reference	Presence	Format	Length	Value
UMA RR Protocol Discriminator	Protocol Discriminator	M	V	½	0110
Skip Indicator	Skip Indicator	M	V	½	0000
URR CLASSMARK ENQUIRY Message Type	Message type	M	V	1	0001 0011
UCI	UCI	M	V	1	0, 1 or 9

Fig. 37A

3600A

URR CLASSMARK ENQUIRY

Information Element	Type/Reference	Presence	Format	Length	Value
Length Indicator	Length Indicator	M	V	2	
UMA RR Protocol Discriminator	Protocol Discriminator	M	V	½	0001
Skip Indicator	Skip Indicator	M	V	½	0000
URR CLASSMARK ENQUIRY Message Identity	Message type	M	V	1	
Classmark Enquiry Mask	Classmark Enquiry Mask	O	TLV	3	

Fig. 37B

3600B

URR CLASSMARK CHANGE

Information Element	Type/Reference	Presence	Format	Length	Value
UMA RR Protocol Discriminator	Protocol Discriminator	M	V	½	0110
Skip Indicator	Skip Indicator	M	V	½	0000
URR CLASSMARK CHANGE Message Type	Message type	M	V	1	0001 0110
UCI	UCI	M	V	1	0, 1 or 9
Mobile Station Classmark	Mobile Station Classmark 2	M	LV	4	10.5.1.6/GSM04.08
Additional Mobile Station Classmark Information	Mobile Station Classmark 3	C	TLV	3-14	10.5.1.7/GSM04.08

Fig. 38A

3602A

URR CLASSMARK CHANGE

Information Element	Type/Reference	Presence	Format	Length	Value
Length Indicator	Length Indicator	M	V	2	
UMA RR Protocol Discriminator	Protocol Discriminator	M	V	½	0001
Skip Indicator	Skip Indicator	M	V	½	0000
URR CLASSMARK CHANGE Message Identity	Message type	M	V	1	
Mobile Station Classmark 2	Mobile Station Classmark 2	M	TLV	5	
Additional Mobile Station Classmark Information	Mobile Station Classmark 3	C	TLV	3-14	

Fig. 38B

3602B

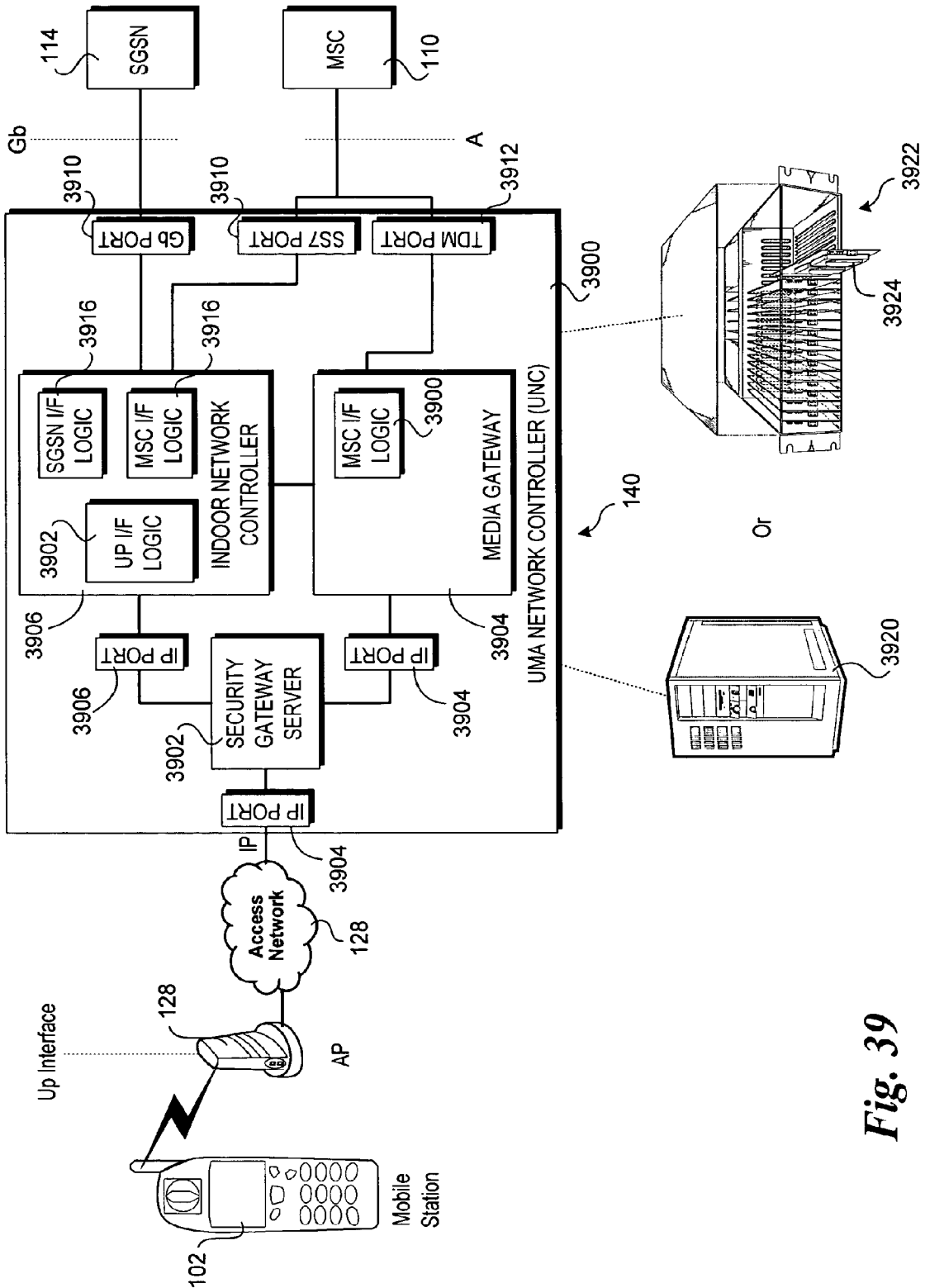

Fig. 39

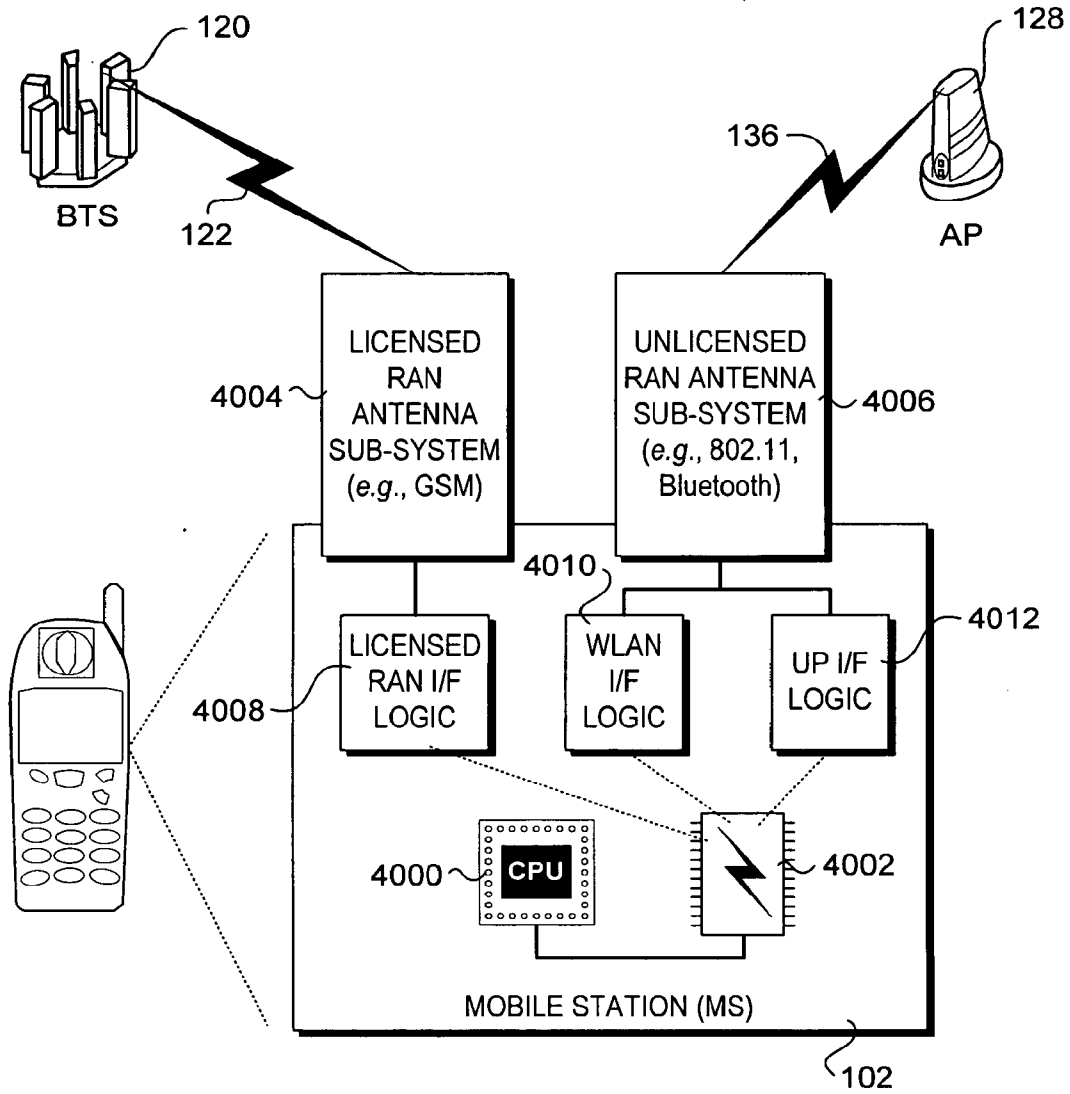

Fig. 40

MESSAGING FOR PAGING A MOBILE STATION IN AN UNLICENSED MOBILE ACCESS TELECOMMUNICATIONS SYSTEM

CROSS-REFERENCE TO RELATED APPLICATIONS

[0001] This application claims the priority of provisional patent application Ser. No. 60/571,421, filed May 14, 2004, and entitled "Up Interface Stage 3 Description." This application is a Continuation in Part of and claims the priority of U.S. Non-provisional application Ser. No. 11/013,883, entitled "Apparatus and Method for Extending the Coverage Area of A Licensed Wireless Communication System Using an Unlicensed Wireless Communication System," filed Dec. 15, 2004, which is a Continuation in Part of U.S. Non-provisional application Ser. No. 10/688,470, entitled "Apparatus and Method for Extending the Coverage Area of a Licensed Wireless Communication System Using an Unlicensed Wireless Communication System," filed Oct. 17, 2003. This application is also a Continuation in Part of and claims the priority of U.S. Non-provisional application Ser. No. 11/097,866, entitled "A Method and System for Registering an Unlicensed Mobile Access Subscriber with a Network Controller," filed Mar. 31, 2005, which claims priority to provisional patent application Ser. No. 60/564,696, filed Apr. 22, 2004 and entitled "UMA Network Controller (UNC) Selection and UMA Location Services Support Mechanisms."

[0002] This application is also related to commonly owned U.S. application Ser. No. 10/115,833, entitled "Unlicensed Wireless Communications Base Station to Facilitate Unlicensed and Licensed Wireless Communications with a Subscriber Device, and Method of Operation," filed Apr. 2, 2002; and application Ser. No. 10/251,901, entitled "Apparatus for Supporting the Handover of a Telecommunication Session between a Licensed Wireless System and an Unlicensed Wireless System," filed Sep. 20, 2002, the contents of each of which are hereby incorporated by reference. In addition, this application contains common subject matter disclosed in U.S. application Ser. No. _____, Attorney Matter Nos. 007090.P032, 007090.P032, 007090.P032, filed concurrently herewith on May 12, 2005.

FIELD OF THE INVENTION

[0003] The field of invention relates generally to telecommunications. More particularly, this invention relates to messaging employed in an unlicensed mobile access (UMA) telecommunication system that includes both licensed and unlicensed radio infrastructure.

BACKGROUND INFORMATION

[0004] Licensed wireless systems provide mobile wireless communications to individuals using wireless transceivers. Licensed wireless systems refer to public cellular telephone systems and/or Personal Communication Services (PCS) telephone systems. Wireless transceivers include cellular telephones, PCS telephones, wireless-enabled personal digital assistants, wireless modems, and the like.

[0005] Licensed wireless systems utilize wireless signal frequencies that are licensed from governments. Large fees are paid for access to these frequencies. Expensive base station (BS) equipment is used to support communications on licensed frequencies. Base stations are typically installed approximately a mile apart from one another (e.g., cellular

towers in a cellular network). The wireless transport mechanisms and frequencies employed by typical licensed wireless systems limit both data transfer rates and range. As a result, the quality of service (voice quality and speed of data transfer) in licensed wireless systems is considerably inferior to the quality of service afforded by landline (wired) connections. Thus, the user of a licensed wireless system pays relatively high fees for relatively low quality service.

[0006] Landline (wired) connections are extensively deployed and generally perform at a lower cost with higher quality voice and higher speed data services. The problem with landline connections is that they constrain the mobility of a user. Traditionally, a physical connection to the landline was required.

[0007] In the past few years, the use of unlicensed wireless communication systems to facilitate mobile access to landline-based networks have seen rapid growth. For example, such unlicensed wireless systems may support wireless communication based on the IEEE 802.11a, b or g standards (WiFi), or the Bluetooth™ standard. The mobility range associated with such systems is typically on the order of 100 meters or less. A typical unlicensed wireless communication system includes a base station comprising a wireless access point (AP) with a physical connection (e.g., coaxial, twisted pair, or optical cable) to a landline-based network. The AP has a RF transceiver to facilitate communication with a wireless handset that is operative within a modest distance of the AP, wherein the data transport rates supported by the WiFi and Bluetooth™ standards are much higher than those supported by the aforementioned licensed wireless systems. Thus, this option provides higher quality services at a lower cost, but the services only extend a modest distance from the base station.

[0008] Currently, technology is being developed to integrate the use of licensed and unlicensed wireless systems in a seamless fashion, thus enabling a user to access, via a single handset, an unlicensed wireless system when within the range of such a system, while accessing a licensed wireless system when out of range of the unlicensed wireless system. unlicensed wireless networks and for directing them to an appropriate network controller. In order to support more rapid implementation by various vendors, a standardized set of messages for performing various functions, such as registration, channel activation, handover, and the like are needed.

SUMMARY OF THE INVENTION

[0009] In accordance with aspects of the present invention, techniques are disclosed for performing messaging between mobile stations (MSs) and UMA network controllers (UNCs) in an unlicensed mobile access network (UMAN). To facilitate various operations, URR (UMA radio resource) messages are exchanged between an MS and one or more UNCs operating in the UMAN. By employing a wireless link using an unlicensed radio frequency, such as an 802.11-based link or a Bluetooth™ link, the MS may access the UMAN via a wireless access point (AP) that is communicatively-coupled to the UNC via an IP network. The URR messages are sent between the MS and the UNC using an Up interface comprising a set of layered protocols over an underlying IP transport.

[0010] In another aspect of the present invention, URR messages with specific formats are disclosed. The messages include a URR CLEAR REQUEST message, a URR RELEASE message, a URR RELEASE COMPLETE message, a URR PAGING REQUEST message, a URR PAGING RESPONSE message, a URR CLASSMARK ENQUIRY

message, and a URR CLASSMARK CHANGE message. Each of the URR messages includes a basic set of information elements (IEs) including a protocol discriminator, a skip indicator, and a message type via which the message may be identified. Further IEs relevant to each particular URR message are also disclosed.

BRIEF DESCRIPTION OF THE DRAWINGS

[0011] The foregoing aspects and many of the attendant advantages of this invention will become more readily appreciated as the same becomes better understood by reference to the following detailed description, when taken in conjunction with the accompanying drawings, wherein like reference numerals refer to like parts throughout the various views unless otherwise specified:

[0012] The foregoing aspects and many of the attendant advantages of this invention will become more readily appreciated as the same becomes better understood by reference to the following detailed description, when taken in conjunction with the accompanying drawings, wherein like reference numerals refer to like parts throughout the various views unless otherwise specified:

[0013] FIG. 1A provides an overview of the indoor access network (IAN) mobile service solution in accordance with one embodiment of the present invention;

[0014] FIG. 1B illustrates protocol layers of a mobile set in accordance with one embodiment;

[0015] FIG. 1C illustrates a method of protocol conversion in accordance with one embodiment;

[0016] FIG. 2A illustrates an overview of a level 1, level 2, and level 3 GSM-related protocol architecture for one embodiment of a mobile station that provides unlicensed radio links via Bluetooth signaling;

[0017] FIG. 2B illustrates an overview of a level 1, level 2, and level 3 GSM-related protocol architecture for one embodiment of a mobile station that provides unlicensed radio links via IEEE 802.11 signaling;

[0018] FIG. 3A illustrates the Up interface protocol architecture in support of CS Domain signaling, as well as UMA-specific signaling, according to one embodiment;

[0019] FIG. 3B shows Bluetooth lower layers employed by a mobile station and access point to facilitate physical layer communications;

[0020] FIG. 3C shows Bluetooth lower layers employed by a mobile station and access point to facilitate physical layer communications;

[0021] FIG. 3D illustrates the Up CS domain voice bearer protocol architecture in support of GSM voice transmission, according to one embodiment;

[0022] FIG. 3E illustrates the Up GPRS user plane protocol architecture, according to one embodiment;

[0023] FIG. 3F illustrates the Up protocol architecture in support of GPRS Signaling, according to one embodiment;

[0024] FIG. 4 illustrates several possible GSM and UMA coverage scenarios in accordance with one embodiment;

[0025] FIG. 5 illustrates exemplary mobility management functions in one embodiment;

[0026] FIG. 6A illustrates a URR Register message exchange corresponding to a successful registration;

[0027] FIG. 6B illustrates a URR Register message exchange corresponding to a rejected registration;

[0028] FIG. 6C illustrates a URR Register message exchange under which an MS is redirected from a first UNC to a second UNC;

[0029] FIGS. 7A and 7B are tables illustrating respective embodiments of a URR REGISTER REQUEST message format;

[0030] FIG. 8A is a table illustrating one embodiment of a URR REGISTER ACK message format;

[0031] FIG. 8B is a table illustrating one embodiment of a UMA GSM System Information element;

[0032] FIG. 8C is a table illustrating one embodiment of a URR REGISTER ACCEPT message format;

[0033] FIG. 9A is a table illustrating one embodiment of a URR REGISTER REJECT/REDIRECT message format;

[0034] FIG. 9B is a table illustrating one embodiment of a URR REGISTER REJECT message format;

[0035] FIG. 9C is a table illustrating one embodiment of a URR REGISTER REDIRECT message format;

[0036] FIG. 10A illustrates a URR message sequence including a URR REGISTER UPDATE UPLINK message and a URR REGISTER REDIRECT message;

[0037] FIG. 10B illustrates a URR message sequence including a URR REGISTER UPDATE DOWNLINK message, a URR DEREGISTER message, and a URR REGISTER REDIRECT message;

[0038] FIGS. 11A and 11B are tables illustrating respective embodiments of a URR REGISTER UPDATE UPLINK message format;

[0039] FIGS. 12A and 12B are tables illustrating respective embodiments of a URR REGISTER UPDATE DOWNLINK message format;

[0040] FIGS. 13A and 13B are tables illustrating respective embodiments of a URR DEREGISTER message format;

[0041] FIG. 14 is a table illustrating one embodiment of a lookup table containing 8-bit values corresponding to causes for various URR actions;

[0042] FIG. 15 illustrates a channel activation message sequence;

[0043] FIGS. 16A and 16B are tables illustrating respective embodiments of a URR ACTIVATE CHANNEL message format;

[0044] FIGS. 17A and 17B are tables illustrating respective embodiments of a URR ACTIVATE CHANNEL ACK message format;

[0045] FIGS. 18A and 18B are tables illustrating respective embodiments of a URR ACTIVATE CHANNEL FAILURE message format;

[0046] FIGS. 19A and 19B are tables illustrating respective embodiments of a URR ACTIVATE CHANNEL COMPLETE message format;

[0047] FIG. 20 illustrates a handover message sequence initiated by a mobile station;

[0048] FIGS. 21A and 21B are tables illustrating respective embodiments of a URR HANDOVER ACCESS message format;

[0049] FIGS. 22A and 22B are tables illustrating respective embodiments of a URR HANDOVER COMPLETE message format;

[0050] FIG. 23A illustrates a handover message sequence initiated in response to a URR UPLINK QUALITY INDICATION message sent from a UNC;

[0051] FIG. 23B illustrates a handover message sequence initiated in response to a URR UPLINK QUALITY INDICATION message sent from a UNC, in accordance with a handover failure;

[0052] FIG. 24 is a table illustrating one embodiment of a URR UPLINK QUALITY INDICATION message format;

[0053] FIGS. 25A and 25B are tables illustrating respective embodiments of a URR HANDOVER REQUIRED message format;

[0054] FIGS. 26A and 26B are table portions illustrating one embodiment of a URR HANDOVER COMMAND message format;

[0055] FIG. 26C is a table illustrating another embodiment of a URR HANDOVER COMMAND message format;

[0056] FIGS. 27A and 27B are tables illustrating respective embodiments of a URR HANDOVER FAILURE message format;

[0057] FIG. 28 illustrates a URR CLEAR REQUEST message sent from a mobile station to a UNC;

[0058] FIGS. 29A and 29B are tables illustrating respective embodiments of a URR CLEAR REQUEST message format;

[0059] FIG. 30 illustrates a URR release message sequence initiated by a UNC;

[0060] FIGS. 31A and 31B are tables illustrating respective embodiments of a URR RR RELEASE message format;

[0061] FIGS. 32A and 32B are tables illustrating respective embodiments of a URR RR RELEASE COMPLETE message format;

[0062] FIG. 33 illustrates a URR paging message sequence initiated by a UNC;

[0063] FIGS. 34A and 34B are tables illustrating respective embodiments of a URR PAGING REQUEST message format;

[0064] FIGS. 35A and 35B are tables illustrating respective embodiments of a URR PAGING RESPONSE message format;

[0065] FIG. 36 illustrates a URR classmark message sequence initiated by a UNC;

[0066] FIGS. 37A and 37B are tables illustrating respective embodiments of a URR CLASSMARK ENQUIRY message format;

[0067] FIGS. 38A and 38B are tables illustrating respective embodiments of a URR CLASSMARK CHANGE message format;

[0068] FIG. 39 is a schematic block diagram illustrating one embodiment of a high-level architecture of a UNC; and

[0069] FIG. 40 is a schematic block diagram illustrating one embodiment of a high-level architecture of a mobile station.

DETAILED DESCRIPTION

[0070] In the following description, numerous specific details are set forth to provide a thorough understanding of embodiments of the invention. One skilled in the relevant art will recognize, however, that the invention can be practiced without one or more of the specific details, or with other methods, components, materials, etc. In other instances, well-known structures, materials, or operations are not shown or described in detail to avoid obscuring aspects of the invention.

[0071] Reference throughout this specification to “one embodiment” or “an embodiment” means that a particular feature, structure, or characteristic described in connection with the embodiment is included in at least one embodiment of the present invention. Thus, the appearances of the phrases “in one embodiment” or “in an embodiment” in various places throughout this specification are not necessarily all referring to the same embodiment. Furthermore, the particular features, structures, or characteristics may be combined in any suitable manner in one or more embodiments.

[0072] In the present description the unlicensed wireless system may be a short-range wireless system, which may be described as an “indoor” solution. However, it will be understood through the application that the unlicensed wireless system includes unlicensed wireless systems that cover not only a portion of a building but also local outdoor regions, such as outdoor portions of a corporate campus serviced by an unlicensed wireless system. The mobile station may, for example, be a wireless phone, smart phone, personal digital assistant, or mobile computer. The “mobile station” may also, for example, be a fixed wireless device providing a set of terminal adapter functions for connecting Integrated Services Digital Network (ISDN) or Plain Old Telephone Service (POTS) terminals to the wireless system. Application of the present invention to this type of device enables the wireless service provider to offer so-called landline replacement service to users, even for user locations not sufficiently covered by the licensed wireless system. The present description is in the context of the UMA (Unlicensed Mobile Access) standardized architecture as promulgated by the UMA consortium. However, the invention is not so limited.

[0073] Throughout the following description, acronyms commonly used in the telecommunications industry for wireless services are utilized along with acronyms specific to the present invention. A table of acronyms specific to this application is included in Appendix I.

[0074] FIG. 1A illustrates an Unlicensed Mobile Access (UMA) architecture 100 in accordance with one embodiment of the present invention. UMA architecture 100 enables a user of a mobile station 102 to access a voice and telecommunications network 104 via either a licensed wireless communications session 106, or an unlicensed wireless communication session 108. The telecommunications network 104 includes a mobile switching center (MSC) 110, which provides access to a voice network 112, and a Serving GPRS (General Packet Radio Service) Support Node (SGSN) 114, which provides access to a data network 116. MSC 110 also provides an internal visitor location register (VLR) function.

[0075] In further detail, the licensed wireless communication session is facilitated by infrastructure provided by a licensed wireless network 118 that includes telecommunications network 104. In the illustrated embodiment, licensed wireless network 118 depicts components common to a GSM-(Global System for Mobile Communication) based cellular network that includes multiple base transceiver stations (BTS) 120 (of which only one is shown for simplicity) that facilitate wireless communication services for various mobile stations 102 via respective licensed radio links 122 (e.g., radio links employing radio frequencies within a licensed bandwidth). Typically, the multiple BTSs 120 are configured in a cellular configuration (one per each cell) that covers a wide service area. The various BTSs 120 for a given area or region are managed by a base station controller (BSC) 124, with each BTS 120 communicatively-coupled to its BSC 124 via a private trunk 126. In general, a large licensed wireless network, such as that provided by a regional or nationwide mobile services provider, will include multiple BSCs 124.

[0076] Each BSC 124 communicates with telecommunications network 104 through a standard base station controller interface 126. For example, a BSC 124 may communicate with MSC 110 via the GSM A-interface for circuit switched voice services and with SGSN 114 via the GSM Gb interface for packet data services (GPRS). Conventional licensed voice

and data networks **104** include protocols to permit seamless handoffs from one recognized BSC **124** to another BSC (not shown).

[0077] An unlicensed communication session **108** is facilitated via an (wireless) access point (AP) **128** comprising an indoor base station **130**. Typically, AP **128** will be located in a fixed structure, such as a home **132** or an office building **134**. The service area of indoor base station **130** includes an indoor portion of a building, although it will be understood that the service area of an indoor base station may include an outdoor portion of a building or campus. As indicated by the arrow representing unlicensed communication session **108**, the mobile station **102** may be connected to the telecommunications network **114** via a second data path that includes an unlicensed wireless channel **136**, access point **128**, an access network **138**, and an unlicensed mobile access network controller (UNC) **140**. The UNC **140** communicates with telecommunications network **104** using a base station controller interface **126B** that is similar to base station controller interface **126A**, and includes a GSM A interface and Gb interface. AP **128** may include software entities stored in memory and executing on one or more microprocessors (not shown in FIG. 1A) adapted to perform protocol conversion.

[0078] The unlicensed wireless channel **136** is facilitated by a radio link employing a wavelength (or wavelength range) in an unlicensed, free spectrum (e.g., spectrum around 2.4 GHz, 5 GHz, 11-66 GHz). An unlicensed wireless service hosting unlicensed wireless channel **136** may have an associated communication protocol. As examples, the unlicensed wireless service may be a Bluetooth™ compatible wireless service, or a wireless local area network (LAN) (WiFi) service (e.g., the IEEE 802.11a, b, or g wireless standard). This provides the user with potentially improved quality of service in the service regions of the unlicensed wireless service (i.e., within the service range of a corresponding AP). Thus, when a subscriber is within range of the unlicensed AP, the subscriber may enjoy low cost, high speed, and high quality voice and data services. In addition, the subscriber enjoys extended service range since the handset can receive services deep within a building at locations that otherwise may not be reliably serviced by a licensed wireless system. At the same time, the subscriber can roam outside the range of the unlicensed AP without dropping communications. Instead, roaming outside the range of the unlicensed AP results in a seamless handoff (also referred to as a handover) wherein communication services are automatically provided by the licensed wireless system, as described in more detail in U.S. patent application Ser. No. 10/115,833, the contents of which are hereby incorporated by reference.

[0079] Mobile station **102** may include a microprocessor and memory (not shown) that stores computer program instructions for executing wireless protocols for managing communication sessions. As illustrated in FIG. 1B, in one embodiment the mobile station **102** includes a layer 1 protocol layer **142**, layer 2 protocol layer **144**, and a layer 3 signaling protocol layer for the licensed wireless service that includes a radio resource (RR) sublayer **146**, a mobility management (MM) sublayer **148**, and a call management (CM) layer **150**. It will be understood that the level 1, level 2, and level 3 layers may be implemented as software modules, which may also be described as software “entities.” In accordance with a common nomenclature for licensed wireless services, layer 1 is the physical layer, i.e., the physical baseband for a wireless communication session. The physical

layer is the lowest layer of the radio interface and provides functions to transfer bit streams over physical radio links. Layer 2 is the data link layer. The data link layer provides signaling between the mobile station and the base station controller. The RR sublayer is concerned with the management of an RR-session, which is the time that a mobile station is in a dedicated mode, as well as the configuration of radio channel, power controller, discontinuous transmission and reception, and handovers. The mobility management layer manages issues that arise from the mobility of the subscriber. The mobility management layer may, for example, deal with mobile station location, security functions, and authentication. The call control management layer provides controls for end-to-end call establishment. These functions for a licensed wireless system are well known by those in the art of wireless communication.

[0080] The mobile station may also include an unlicensed wireless service physical layer **152** (i.e., a physical layer for unlicensed wireless service such as Bluetooth, WiFi, or other unlicensed wireless channel (e.g., WiMAX)). The mobile station also includes an unlicensed wireless service level 2 link layer **154**, and an unlicensed wireless service radio resource sublayer(s) **156**. An access mode switch **160** is included for the mobile management **148** and call management layers **150** to access the unlicensed wireless service radio resource sublayer **156** and unlicensed wireless service link layer **154** when the mobile station **102** is within range of an unlicensed AP **128** and to support switching between licensed RR sublayer **146** and unlicensed wireless service RR sublayer **156**.

[0081] The unlicensed radio resource sublayer **156** and unlicensed link layer **154** may include protocols specific to the unlicensed wireless service utilized in addition to protocols selected to facilitate seamless handoff between licensed and unlicensed wireless systems. Consequently, the unlicensed radio resource sublayer **156** and unlicensed link layer **154** need to be converted into a format compatible with a conventional base station controller interface protocol **126** recognized by a MSC, SGSN, or other voice or data network.

[0082] Referring to FIG. 1C, in one embodiment of the present invention, the mobile station **102**, AP **128** and UNC **140** provide an interface conversion function to convert the level 1, level 2, and level 3 layers of the unlicensed service into a conventional base station subnetwork (BSS) interface **126B** (e.g., an A-interface or a Gb-interface). As a result of the protocol conversion, a communication session may be established that is transparent to the voice network/data network **104**, i.e., the voice/data network **104** uses its standard interface and protocols for the communication session as it would with a conventional communication session handled by a conventional base transceiver station. For example, in some embodiments the mobile station **102** and UNC **140** are configured to initiate and forward location update and service requests. As a result, protocols for a seamless handoff of services that is transparent to voice/data network **104** are facilitated. This permits, for example, a single phone number to be used for both the licensed wireless service and the unlicensed wireless service. Additionally, the present invention permits a variety of services that were traditionally offered only through licensed wireless services to be offered through an unlicensed wireless service. The user thus gets the benefit of potentially higher quality service when their mobile

station is located within the area serviced by a high bandwidth unlicensed wireless service while also having access to conventional phone services.

[0083] The licensed wireless service may comprise any licensed wireless service having a defined BSS interface protocol **126** for a voice/data network **104**. In one embodiment, the licensed wireless service is a GSM/GPRS radio access network, although it will be understood that embodiments of the present invention include other licensed wireless services. For this embodiment, the UNC **140** interconnects to the GSM core network via the same base station controller interfaces **126** used by a standard GSM BSS network element. For example, in a GSM application, these interfaces are the GSM A-interface for circuit switched voice services and the GSM Gb interface for packet data services (GPRS). In a UMTS (Universal Mobile Telecommunications System) application of the invention, the UNC **140** interconnects to the UMTS network using a UMTS Iu-cs interface for circuit switched voice services and the UMTS Iu-ps interface for packet data services. In a CDMA application of the invention, the UNC **140** interconnects with the CDMA network using the CDMA A1 and A2 interfaces for circuit switched voice services and the CDMA A10 and A11 interfaces for packet data services.

[0084] In a GSM/GPRS embodiment, UNC **140** appears to the GSM/GPRS core network as a GSM BSS network element and is managed and operated as such. In this architecture the principle elements of transaction control (e.g., call processing) are provided by higher network elements; namely the MSC **110** visitor location register (VLR) and the SGSN **114**. Authorized mobile stations are allowed access to the GSM/GPRS core network either directly through the GSM radio access network if they are outside of the service area of an AP **128** or via the UMA network system if they are within the service area of an AP.

[0085] Since a communication session hosted by the UMA architecture **100** is transparent to a voice network **112** or data network **116**, the unlicensed wireless service may support all user services that are typically offered by a wireless service provider. In the GSM case, this typically includes the following basic services: Telephony; Emergency call (e.g., E911 calling in North America); Short message, mobile-terminated point-to-point (MT/PP); Short message, mobile-originated point-to-point (MO/PP); GPRS bearer services; and Handover (outdoor-to-indoor, indoor-to-outdoor, voice, data, SMS, SS). Additionally, GSM may also support, various supplementary services that are well-known in the art.

[0086] FIG. 2A provides an overview of a level 1, level 2, and level 3 GSM-related protocol architecture for one embodiment of mobile station **102** that provides unlicensed radio links via Bluetooth signaling. As illustrated, there are two logical radio resource (RR) management entities: the GSM RR entity **202** and the UMA-RR entity **204**. The protocol architecture includes a GSM baseband level 1 layer **206**, GSM level 2 link layer (LAPDm) **208**, Bluetooth baseband level 1 layer **210**, Bluetooth level 2 layers **211** including a layer 2 connection access procedure (L2CAP) layer **212** and a BNEP layer **213**, an access mode switch **214**, and upper layer protocols **216**. When the mobile station is operating in an UMA mode, the UMA-RR entity **204** is the current "serving" RR entity providing service to the mobility management (MM) sublayer via the designated service access point (RR-SAP). The GSM RR entity is detached from the MM sublayer in this mode. The UMA-RR entity **204** provides a new set of functions, and is responsible for several tasks. First the UMA-

RR entity is responsible for discovery of UMA coverage and UMA registration. Second, the UMA-RR entity is responsible for emulation of the GSM RR layer to provide the expected services to the MM layer; i.e., create, maintain and tear down RR connections. All existing GSM 04.07 primitives defined for the RR-SAP apply. The plug-in of UMA-RR entity **204** is made transparent to the upper layer protocols in this way. Third, a UMA-RR entity **204** module is responsible for coordination with the GSM RR entity to manage access mode switching and handover, as described in further detail in application Ser. No. 10/688,470 referenced above.

[0087] FIG. 2B provides an overview of a level 1, level 2, and level 3 GSM-related protocol architecture for one embodiment of mobile station **102** that provides unlicensed radio links via IEEE 802.11 signaling. All of the entities and layers are the same as described above for FIG. 2A, except that the Bluetooth layers have been replaced with an 802.11 PHY layer **218** and an 802.11 MAC layer **220**.

[0088] FIG. 3A illustrates the Up interface protocol architecture in support of circuit switched (CS) Domain signaling, as well as UMA-specific signaling, according to one embodiment. The MSC sublayers are conventional, well known features known in the art in regards to the message transfer part (MTP) interfaces MTP1 **302**, MTP2 **304**, and MTP3 **306**, signaling connection control part (SCCP) **308**, base station system application part (BSSAP) **310**, mobility management interface **312**, and connection management interface **314**.

[0089] The UMA-RR protocol supports the UMA "layer 3" signaling functions via UMA-RR layers **204** provided by each of the mobile station **102** and UNC **140**. The UNC **140**, acting like a BSC, terminates UMA-RR protocol messages and is responsible for the interworking between these messages and the analogous A-interface messages.

[0090] The layers below the UMA-RR layer **204** in each of mobile station **104** and UNC **140** include a TCP layer **316**, a remote IP layer **318**, and an IPSec (IP security) layer **320**. As an option, a standard Secure Socket Layer (SSL) protocol running over TCP/IP (not shown) may be deployed in place of IPSec layer **320**.

[0091] Lower-level IP connectivity between mobile station **102** and UNC **140** is supported by appropriate layers hosted by an intervening access point **128** and broadband IP network **138** (i.e., the access network **138** shown in FIG. 1A). The components for supporting the IP transport layer (i.e., the conventional network layer 3 under the seven-layer OSI model) include a transport IP layers **322** for each of the mobile station **104**, AP **128**, and IP network **138**, and an IP layer **322A** at UNC **140**.

[0092] At the lowest layers (i.e., the physical and data link layers), mobile station **104** and AP **128** are depicted as providing unlicensed lower layers **324**, while each of AP **128**, IP network **138**, and UNC **140** provide appropriate access layers **326**. Typically, access layers **326** will include conventional Ethernet PHY and MAC layers (IEEE 802.3), although this is not limiting.

[0093] As shown in FIGS. 3A and 3B, the unlicensed layers lower layers **324** will depend on whether the unlicensed radio link uses Bluetooth signaling or IEEE 802.11 signaling. The Bluetooth lower layers depicted in FIG. 3A correspond to the mobile station architecture of FIG. 2A, and include a Bluetooth baseband layer **210**, an L2CAP layer **212**, and a BNEP layer **213**. Meanwhile, the 801.11 lower layers shown in FIG.

3B correspond to the mobile station architecture of FIG. 2B, and include a 802.11 PHY layer 218 and in 802.11 MAC layer 220.

[0094] FIG. 3D illustrates the Up CS domain voice bearer protocol architecture in support of GSM voice transmission, according to one embodiment. In addition to the like named and referenced components common to the architectures of FIGS. 3D and 3C, facilities are provided for supporting GSM voice transmission. For the MSC 110, these components include conventional components for supporting GSM voice transmissions, and are depicted as physical layers 330 and audio 332, with similar components being deployed in UNC 140. Each of mobile station 102 and UNC 140 now include a GERAN (GSM Edge Radio Access Network) codec 334 and an RTP/UDP layer 336.

[0095] Under the architecture of FIG. 3D, audio flows over the Up interface according to the RTP framing format defined in RFC 3267 and RFC 3551. When operating in UMA mode, support for AMR FR as specified in TS 26.103 is supported. Other codecs may also be supported, such as G.711.

[0096] FIG. 3E illustrates the Up GPRS user plane protocol architecture, according to one embodiment. The Up GPRS user plane protocol architecture effectively enables the tunneling of GPRS signaling and data packets through the UNC 140 utilizing the unlicensed spectrum, thus supporting a tunneling function for packet-switched traffic between the mobile station 102 and SGSN 118.

[0097] As illustrated in FIG. 3E, each of the UNC 140 and SGSN 114 employ conventional facilities for supporting GPRS signaling and data packets, including a physical layer 350, a network service layer 352, and a BSSGP layer 354. Each of mobile station 102 and UNC 140 include a UDP layer 356 and a UMA-RLC layer 358. Each of mobile station 102 and SGSN 114 include an LLC layer 360 and an SMDCP layer 362. Mobile station 102 also includes an IP layer 364.

[0098] Under the architecture of FIG. 3E, GPRS LLC PDUs carrying data, and higher layer protocols, are carried transparently between the mobile station 102 and SGSN 114. This allows the mobile station to derive all GPRS services in the same manner as if it were in a GERAN BSS. All existing GPRS applications and MMI in mobile station 102 are unchanged. LLC PDUs are carried over UMA-RLC layer 358 from mobile station 102 to UNC 140, which relays the PDUs over to SGSN 114 using BSSGP messaging. The UMA-RLC layer 358 runs directly over the UDP layer 356 to leverage the IP bearer service.

[0099] FIG. 3F illustrates the Up protocol architecture in support of GPRS Signaling, according to one embodiment. Under this architecture, the GPRS LLC PDUs for signaling on higher layer protocols (including upper layers 366) are carried transparently between MS 102 and SGSN 114. This allows the MS to obtain all GPRS services in the same ways as if it were connected to a GERAN BSS. The GPRS-RLC protocol is replaced with an equivalent (from the upper layer perspective) UMA-RLC protocol. Reliability is ensured by TCP layer 357. As in a GERAN BSS, the UNC, acting like a BSC, terminates the UMA-RLC protocol and inter-works it to the Gb-interface using BSSGP.

[0100] As noted above, the mobile station may be, for example, a wireless phone, smart phone, personal digital assistant, or mobile computer. The mobile station may also be, for example, a fixed wireless device providing a set of terminal adapter functions for connecting Integrated Services

Digital Network (ISDN) or Plain Old Telephone Service (POTS) terminals to the wireless system.

[0101] Other terminal adapter types than those listed above may be employed with embodiments of the present invention. For example: (1) a terminal adapter that supports cordless telephones rather than POTS phones; (2) a terminal adapter that supports standard Session Initiation Protocol (SIP) telephones; and (3) a terminal adapter that also integrates a corded handset and user interface, such as one would find on a desk phone. In each case, the invention described herein describes how these terminal adapter functions can be connected to the wireless system via the unlicensed network.

[0102] The use of other standard Bluetooth capabilities together with embodiments of the present invention is possible. For example, there is a Bluetooth standard capability called "SIM Access Profile" that allows one Bluetooth device (e.g., an embedded cell phone subsystem in a car) to access the SIM that is in another Bluetooth device (e.g., the user's normal cell phone), allowing the first device to take on the "personality" associated with the SIM (i.e., that of the user's normal cell phone). The embodiments described above could make use of this standard capability to give the terminal adapter-attached devices (e.g., a POTS phone) the personality of the user's cell phone.

Mobility Management

[0103] The UNC 140 provides functions equivalent to that of a GSM BSC, and as such controls one or more (virtual) UMA cells. In one embodiment, there may be a single UMA cell per UNC and, in an alternative embodiment, there may be one UMA cell per access point connected to a UNC. The latter embodiment may be less desirable due to the large number of APs expected to be used, so the UMA architecture permits flexible groupings of APs into UMA cells. Each UMA cell may be identified by a cell global identifier (CGI), with an unused absolute radio frequency channel number (ARFCN) assigned to each UMA cell. Each UMA cell may be mapped to a physical boundary by associating it with specific GSM location areas served by the MSC. GSM cells within the location areas mapped to a UMA cell are configured with ARFCN-to-CGI mappings for that UMA cell. Further, this ARFCN may be advertised in the BA list by the GSM cells to permit handovers. Note that UMA cells may use the same location area identifiers (LAI) as existing GSM cells, or a new LAI may be used for UMA cells. The latter is useful in reducing paging in GSM cells when a mobile station is known to be registered via an INC. The above discussion applies equally to GPRS routing areas and routing area identifiers (RAIs).

UMA CPE Addressing

[0104] Customer premise equipment (CPE) may include the mobile station and the access point (AP) through which the mobile station may access the UNC for UMA service. UMA CPE addressing parameters may include the parameters described below.

[0105] The UMA CPE addressing includes the international mobile subscriber identity (IMSI) associated with the SIM in the mobile equipment as a parameter. The IMSI is provided by the UMA mobile station to the UNC when it requests UMA service via the Up interface to the UNC. Unlike the GSM BSC, the UNC manages a context for each mobile station that is operating in UMA mode. Therefore, the

UNC maintains a record for each served mobile station. For example, IMSI may be used by the UNC to find the appropriate mobile station record when the UNC receives a BSS-MAP paging message.

[0106] The UMA CPE addressing includes the address associated with the unlicensed interface in the mobile equipment (e.g., 802.11 MAC address) as a parameter. This identifier may be provided by the UMA mobile station to the UNC when it requests UMA service via the Up interface. The UNC may use this address as an alternative to the IMSI to limit the transfer of the IMSI over the Up interface and to assist in the routing of messages.

[0107] The UMA CPE addressing also includes the temporary logical link identifier (TLLI) assigned to the mobile station by the serving GPRS support node (SGSN) as a parameter. This identifier may be provided via standard Gb-interface procedures. The UNC may track this address for each served mobile station to support GSM Gb-interface procedures (e.g., so that downlink GPRS packets may be routed to the correct mobile station).

[0108] The UMA CPE addressing also includes the access point ID (AP-ID) as a parameter. The AP-ID may be the MAC address of the unlicensed mode access point through which the mobile station is accessing UMA service. This identifier may be provided by the UMA mobile station to the UNC when it requests UMA service via the Up interface. The AP-ID may be used by the UNC to support location services (e.g., enhanced 911 service) to the user based on the AP from which the service is being accessed. The AP-ID may also be used by the service provider to restrict UMA service access only to authorized APs.

[0109] Other CPE addressing parameters that may be used depend on the security requirements of the Up interface (e.g., the need to manage UMA mobile station IP addresses for message routing via tunneled IPsec connections, or the need to manage local credentials assigned to the mobile station by the UNC).

UMA Cell Identification

[0110] In order to facilitate the mobility management functions in GSM/GPRS, the coverage area may be split into logical registration areas called location areas (for GSM) and routing areas (for GPRS). Mobile stations may be required to register with the network each time the serving location area (or routing area) changes. One or more location area identifiers (LAIs) may be associated with each visited location register (VLR) in a carrier's network. Likewise, one or more routing area identifiers (RAIs) may be controlled by a single SGSN.

[0111] In one embodiment, a GSM cell is identified within the location or routing area by adding a cell identity (CI) to the location or routing area identification. The cell global identification (CGI) is the concatenation of the location area identification and the cell identity. In one embodiment, the cell identity is unique within a location area.

An Example UMA Approach to Cell Identification

[0112] One example of a UMA cell identification approach is described below. In this embodiment, a single UNC provides service for one or more UMA location areas and one or more UMA routing areas, and each UMA location area (or routing area) is distinct from, or the same as, the location area (or routing area) of the overlapping GSM cell. A UMA cell is

identified within the UMA location or routing area by adding a cell identity (CI) to the location or routing area identification. The UMA cell global identification (UMA-CGI) is the concatenation of the location area identification and the cell identity. In one embodiment, a UMA cell may be a pre-defined partition of the overall UMA coverage area identified by a UMA-CGI value. Note that cell identification, like UMA information, may be transparent to the AP, such that the AP is not aware of its associated UMA-CGI value. The UMA components (e.g., mobile station and UNC) may support the ability to partition the overall UMA coverage area.

[0113] A partitioning method may include implementing a one-to-one or a many-to-one correspondence between GSM cell identity and UMA cell identity. Given the identification of a preferred GSM cell in a particular area, it may be possible to determine the corresponding UMA cell identity based, for example, on UNC provisioning. An example of a one-to-one relationship is mapping a GSM cell to a UMA cell. An example of a many-to-one relationship is mapping a GSM location area (and associated GSM cells) to a UMA cell.

[0114] When a UMA mobile station connects to the UNC for UMA service, it sends the CGI value and (optionally) a path loss criterion parameter (C1) of the current GSM camping cell, as well as the neighbor cells, to the UNC. The UNC maps the GSM camping cell's CGI value to a corresponding UMA cell's CGI value based on mapping logic provisioned in the UNC. This may be a one-to-one mapping (e.g., if there is one UMA cell per GSM cell) or a many-to-one mapping (e.g., if there is one UMA cell per GSM location area). If no GSM coverage is available in the UMA service area, the UNC may assign the mobile station to a default "no GSM coverage" UMA cell. A single UNC may serve one MSC. This does not preclude UNC embodiments that combine multiple UNC "instances," as defined above, in a single device (for example, a UNC that servers multiple MSCs). Each UNC may also be assigned a unique "UMA-Handover-CGI" value used for GSM-to-UMA handover purposes. For example, this may be the value provisioned in the GSM RAN BSC's ARFCN-to-CGI tables and in the MSCs (e.g., to point to the UNC).

UMA Operating Configurations

[0115] In one embodiment, at least three UMA operating configurations may be identified. In a common core configuration, the UMA LAI and an umbrella GSM RAN LAI (e.g., that serves the subscriber's neighborhood) may be different, and the network may be engineered such that the same core network entities (e.g., MSC and SGSN) serve both the UMA cells and the umbrella GSM cells. One advantage of this configuration is that subscriber movement between the UMA coverage area and the GSM coverage area does not result in inter-system (e.g., MAP) signaling (e.g., location updates and handovers are intra-MSC).

[0116] In a separate core configuration, the UMA LAI and umbrella GSM RAN LAI are different, and the network may be engineered such that different core network entities serve the UMA cells and the umbrella GSM cells. One advantage of this configuration is that engineering of the UMA and GSM networks can be more independent than in the Common Core Configuration.

[0117] In a common LAI configuration, the UMA LAI and GSM RAN LAI are the same (e.g., different cells within the same LAI). Advantages of this configuration are that subscriber movement (while idle) between the UMA coverage area and the GSM coverage area may not result in any loca-

tion update signaling, and that the mobile station can easily switch to GSM mode if UMA mode resources are temporarily unavailable (e.g., to respond to paging). Further details of this and the foregoing separate core configuration are discussed in application Ser. No. 10/688,470.

UMA Registration and Deregistration

[0118] In one embodiment, as described above, a UMA registration process does not employ signaling to the PLMN infrastructure and is contained within the UMA system (i.e., between the mobile station and UNC). The UMA registration process may serve at least two purposes. It may inform the UNC that a mobile station is connected through a particular AP and is available at a particular IP address. The UNC may keep track of this information, for example, for mobile-terminated calling. The registration process may also provide the mobile station with the operating parameters associated with the UMA service on the AP. This may be analogous to the use of the GSM broadcast control channel (BCCH) to transmit system parameters to mobile stations in GSM cells. GSM system information message content that is applicable in UMA mode may be delivered to the mobile station during the UMA registration process.

[0119] Similarly, a UMA deregistration process may allow the mobile station to explicitly inform the UNC that it is leaving UMA mode, allowing the UNC to free resources that it may have assigned to the mobile station. The UNC may also support implicit UMA deregistration, wherein a secure channel to the mobile station is abruptly terminated.

UMA Redirection

[0120] In one embodiment, as described above, when a UMA mobile station connects to the UNC for UMA service, it may send a CGI value and a path loss criterion parameter (C1) of the current GSM camping cell, as well as the neighbor cells, to the UNC. Using this information, as well as internal database information, the UNC may be able to determine if it is the correct serving UNC for the mobile station, and if it is not the correct serving UNC, to redirect the mobile station to the correct UNC. The correct serving UNC may be the UNC whose UMA service area overlaps the mobile station's umbrella GSM coverage. In one embodiment, the correct serving UNC might be attached to the same MSC as the GSM BSC to which the umbrella GSM cell belongs. In an alternative embodiment, the correct serving UNC might be attached to a different MSC that may hand-over to the MSC that provides umbrella GSM coverage to the mobile station, allowing the UNC to handover calls to and from GSM. It may also enable certain location-based services (e.g., E911 Phase 1) that can be tied to the location of the GSM cell. An internal database used by the UNC may map GSM location areas to serving UNC's and conserve the amount of data that needs to be managed. This database may only need to change when a new UNC or a new GSM location area is added.

[0121] If no GSM coverage is available when a mobile station connects to the UNC for UMA service, then, under some instances, the UNC may not reliably determine the location of the mobile station for the purposes of assigning the mobile station to the correct serving UNC (e.g., to enable handover and location-based services). The UNC may permit the operator to determine the service policy in this case (e.g., the operator may provide service to the user with certain limitations, possibly with a user interface indication on the

mobile station). Additional details on UMA registration and redirection procedures are provided below.

UMA Mobile Station Idle Mode Behavior

[0122] As described above, a UMA device may encounter different radio environments as illustrated in FIG. 4. In a first environment, the GSM and UMA coverage areas are completely separate and non-overlapping. In a second environment, the GSM and UMA coverage is partially overlapping. In a third environment, which may be the most common, the UMA coverage is encapsulated within the GSM coverage. A UMA device may power on in any of these environments and further may transition in a number of attached states.

[0123] At power on, and when the mobile station is idle and there is no coverage of any type, the mobile station may scan for both GSM and UMA radio coverage. If GSM coverage is detected, then the normal GSM mobility management procedure may be initiated. This condition may apply when no UMA coverage has been detected by the mobile station when GSM coverage is detected, or prior to the completion of the UMA registration process. If UMA coverage is detected, then the UMA mobile station establishes an unlicensed wireless link (e.g., WLAN link) to the AP and monitors signal quality. When the received signal level at the mobile station passes a predefined threshold, the mobile station performs the UMA registration procedure. Based upon the information returned, the mobile station may determine if a full network registration is required, and if so, what type (e.g., GSM or combined GSM/GPRS). This procedure may apply when no GSM coverage exists or when UMA coverage is detected prior to detecting GSM coverage.

[0124] When the mobile station is idle in GSM coverage, and there is no UMA coverage, the mobile station may periodically scan for UMA coverage. If UMA coverage is detected, the mobile station may initiate the UMA registration procedure described above.

[0125] When the mobile station is idle in UMA coverage and there is no GSM coverage, the mobile station may continue to perform normal GSM PLMN search procedures. If GSM coverage is detected, the mobile station may send the GSM cell information to the UNC for possible UMA redirection purposes as described above. Alternatively, the mobile station may disable normal GSM PLMN search procedures to conserve power.

[0126] When the mobile station is idle in UMA coverage, and there is GSM coverage, the mobile station may continue to perform normal GSM cell reselection procedures and may store the identification of the selected GSM cell to speed the transition to GSM mode, if required. Alternatively, the mobile station may disable normal GSM cell reselection procedures to conserve power.

[0127] At power off in UMA coverage, a detach indication may be sent by the mobile station to the PLMN via the UMAN (e.g., if required by the PLMN network or normally sent by the mobile station at power off). This indication may be encoded per the current GSM mode of operation (e.g., GSM or GPRS).

[0128] The UMA environment may be an IEEE 802.11 environment. In this case, the mobile station periodically performs an active scan for available 802.11 APs. When an AP is discovered, it may be matched against a stored profile of user preferences and security credentials, in which case the mobile station may automatically associate with the AP. The

mobile station may enter low-power sleep mode, waking up periodically to measure signal quality for determining when to trigger UMA registration.

[0129] The UMA environment may be a Bluetooth environment. In this case, the mobile station previously paired with the Bluetooth AP through which it will access UMA service. Periodically, the mobile station may enter a page scan receive mode, and respond to an AP transmit page to establish a link-level connection. Once a link-level control channel is established, and if the mobile station is not otherwise active, it may enter a low-power Bluetooth state (e.g., park mode) to conserve power. Periodically, the AP may poll the mobile station to allow it to re-enter active-power mode. This periodic traffic may also be used by the mobile station to measure signal quality to determine when to perform the UMA registration procedure.

UMA Mobile Station Dedicated Mode Behavior

[0130] A UMA device engaged in a voice call, a data transaction or a simultaneous voice/data transaction may encounter a transition from GSM coverage to UMA coverage or a transition from UMA coverage to GSM coverage. In one embodiment, when the coverage transitions from GSM to UMA coverage, calls may be handed over transparently between the GSM RAN and the UMAN. In the case of voice, the handover may be accomplished by a handover function. In the case of data, session management controls may provide a common end-user experience to that provided in GPRS. Normal registration actions may occur upon a return to the idle state, if appropriate. When the coverage transitions from UMA to GSM coverage, calls may be handed over transparently between the UMAN and the GSM RAN. In the case of voice, the handover may be accomplished by a handover function. In the case of data, session management controls may provide a common end-user experience to that provided in GPRS.

Summary of Key Mobility Management Concepts

[0131] FIG. 5 illustrates mobility management functions in one example embodiment. In FIG. 5, unlicensed network controller UNC-1 is the serving UNC for the UMA cells associated with GSM location areas LA-11 to LA-23. UNC-1 maps GSM location areas LA-1x to UMA cell UMA CGI-101 and GSM location areas LA-2x to UMA CGI-102. Unlicensed network controller UNC-3 is the serving UNC for the UMA cells associated with GSM location areas LA-31 to LA-33. UNC-3 maps GSM location areas LA-3x to UMA cell UMA CGI-301. Mobile station MS-1 will be in UMA cell UMA-CGI-101 (since GSM LA-1x is mapped to UMA-CGI-101). Mobile station MS-2 will be in UMA cell UMA-CGI-102 (since GSM LA-2x mapped to UMA-CGI-102). Mobile station MS-3 will be in UMA cell UMA-CGI-301 (since GSM LA-3x mapped to UMA-CGI-301). If mobile station MS-4 connects to UNC-1, it will be in UMA cell UMA-CGI-199 (no GSM coverage). If MS-4 connects to UNC-3, it will be in UMA cell UMA-CGI-399 (no GSM coverage). Mobile stations MS-1 and MS-2 may connect to UNC-1 without redirection. If mobile station MS-3 attempts to connect to UNC-1, it may be redirected to UNC-3.

UMA Radio Resource (URR) Messaging and Message Formats

[0132] In accordance with aspects of the present invention, details of UMA Radio Resource (URR) messaging and cor-

responding message formats to support and manage mobility of mobile stations are now disclosed. The particular format of each message is exemplary, and the formats are merely illustrative of information elements that should and/or may be included in a particular implementation, with some of the information elements being optional.

[0133] The UMA-RR messages are conveyed over the Up interface using the TCP connection. The UMA-RR message format follows the standard GSM layer 3 message structure defined in GSM04.07. Each message consists of the following elements:

[0134] 1. UMA-RR protocol discriminator—To ease the interworking with the GSM RR protocol, in one embodiment the UMA-RR protocol reuses the same protocol discriminator as the GSM RR, which is the binary sequence of 0110 for bits 3 to 0 of the first octet of every UMA-RR message. It is noted that this is merely exemplary, as other sequences may be used, depending on the particular implementation.

[0135] 2. Skip Indicator—In one embodiment, Bits 5 to 8 of the first octet of every UMA-RR message contains the skip indicator. An UMA-RR message received with skip indicator other than 0000 shall be ignored. The UMA-RR entity shall always encode the skip indicator as 0000.

[0136] 3. Message Type—the message type IE (information element) and its use are defined in GSM04.07. The UMA-RR message types for one embodiment are listed in Table 1 below.

[0137] 4. UMA-RR Connection Indicator (UCI)—In one embodiment, the UCI is used to explicitly indicate the first message on the UMA-RR connection, versus subsequent messages on the connection. This allows the MS and the UNC to synchronize their respective UMA-RR connection states. A UCI is not present in another embodiment.

[0138] i. The MS normally sets UCI to the value ‘1’ to indicate that the message is the first on the new UMA-RR connection.

[0139] ii. However, if the UMA connection is for an emergency call, the MS sets UCI to the value ‘9’. This allows the UNC to give priority to emergency call-related UMA-RR connection requests.

[0140] iii. For all other messages associated with the UMA-RR connection, the MS sets UCI to the value ‘0’.

[0141] iv. For example, if the MM sublayer in the MS requests a new UMA-RR connection and then sends a CM-SERVICE-REQUEST message, the UMA-RR entity in the MS sets UCI=1. If the MM sublayer reuses an existing UMA-RR connection to send the CM-SERVICE-REQUEST message, the UMA-RR entity in the MS sets UCI=0. The UCI is used to indicate the implicit allocation of resources for a UMA-RR session.

[0142] 5. Other information elements, as required.

[0143] i. The Presence column indicates whether an information element is mandatory (“M”), optional (“O”) or conditionally present (“C”).

[0144] ii. The Format column indicates how the IE is formatted: “TLV” for tag-length-value format, “LV” for length-value and “V” for value only. The tag for the IE is also referred to as the Information Element Identifier (IEI). Mandatory information elements use

“V” or “LV” format, depending on whether they are fixed or variable length. Optional and conditional information elements always use “TLV” format.

[0145] 5. Length Indicator. In one embodiment, a separate Length Indicator IE is used to specify the length of a given message. In another embodiment, the underlying transport layer is used to provide a length indication for each message. Accordingly, a separate Length Indicator IE is not included in this message format. Both types of formats are illustrated by the URR messages disclosed herein.

TABLE 1

MESSAGE NAME	MESSAGE TYPE
URR REGISTER REQUEST	0011 0011 (0x33)
URR REGISTER ACK	0011 0110 (0x36)
URR REGISTER REJECT	0011 0111 (0x37)
URR ACTIVATE CHANNEL	0010 1110 (0x2E)
URR ACTIVATE CHANNEL ACK	0010 1001 (0x29)
URR ACTIVATE CHANNEL FAILURE	0010 1111 (0x2F)
URR ACTIVATE CHANNEL COMPLETE	0010 1010 (0x2A)
URR HANDOVER REQUIRED	0001 0001 (0x11)
URR HANDOVER COMMAND	0010 1011 (0x2B)
URR HANDOVER COMPLETE	0010 1100 (0x2C)
URR HANDOVER FAILURE	0010 1000 (0x28)
URR HANDOVER ACCESS	0010 1101 (0x2D)
URR RR RELEASE	0000 1101 (0x0D)
URR RR RELEASE COMPLETE	0000 1111 (0x0F)
URR PAGING REQUEST	0010 0001 (0x21)
URR PAGING RESPONSE	0010 0111 (0x27)
URR CLASSMARK CHANGE	0001 0110 (0x16)
URR CLASSMARK ENQUIRY	0001 0011 (0x13)
URR RR CLEAR REQUEST	0011 1111 (0x3F)
URR DEREGISTER	0011 1011 (0x3B)
URR UPLINK QUALITY INDICATION	0010 0110 (0x26)
URR REGISTER UPDATE UPLINK	0011 1100 (0x3C)
URR REGISTER UPDATE DOWNLINK	0011 1101 (0x3D)

Registration Messages and Messages Formats

[0146] FIGS. 6A-C show examples of sequences of messages that are passed between an MS and a UNC (via an AP connected therebetween) under various registration scenarios. Messages and associated signals passing between the different elements are shown as horizontal arrows with arrowheads connecting the elements of the communication systems that are involved. When the arrow passes across an element and no arrowhead is shown, then this element functions as a pass through. The particular elements of the system architecture of FIG. 1 that are involved in FIGS. 6A-C are, from left to right, a mobile station (e.g., MS 102), an access point (e.g., WLAN AP 128), a first UNC (e.g., UNC-1 (UNC 140A)) and a second UNC (e.g., UNC-2 (UNC 140B)).

[0147] Prior to the registration process, various operations are performed to establish a connection with between MS 102 and AP 128, and then to establish a connection between MS 102 and UNC 140. At step A of FIG. 6A, the MS 102 comes into the coverage range of AP 128 and establishes a wireless link with the AP. For example, this wireless link may be a WLAN connection using unlicensed frequencies under the IEEE 802.11 or Bluetooth protocols. At step B, the MS looks for a UNC to establish a connection with. This may be done by performing a DNS (Domain Name System) query for a UNC. This initiates a connection to the first UNC’s IP address. The MS may select the first UNC because it is the last UNC IP address that it used or it may be a default UNC or it

may be a home UNC that the MS is assigned to for initial registrations, or it may be selected from a cache of connected UNC’s indexed by the AP and CGI. At step C, the UNC and the MS establish a secure TCP connection. Note that IPsec security procedures between the MS and UNC are not shown in FIGS. 6A-C.

[0148] At step D, the MS sends a request for registration embodied as a UMA URR-REGISTER REQUEST message 600 to the UNC. Respective embodiments of URR REGISTER REQUEST message formats 600A and 600B are shown in FIGS. 7A and 7B. For illustrative purposes, each message format illustrated herein includes an Information Element column, a Type/Reference column, a Presence column, a Format column, a Length Column, and a Value column. The message formats may also employ IEI Information Element Identifiers (IEIs), which are not shown herein for simplicity and clarity. It is noted that the actual messages will include a value that identifies the message type or identity, along with appropriate IE values in accordance with each particular message format. Also, as with each of the messages discussed herein, URR REGISTER REQUEST message 600 includes a UMA RR protocol Discriminator IE, a Skip Indicator IE, and a Message Type IE (URR REGISTER REQUEST in this instance). As used herein, these three IEs are referred to as “basic” IEs to indicate they are included in each message format. Additionally, one set of message formats includes a UCI IE, while another set of message formats includes a Length Indicator IE for each message.

[0149] In addition to the basic IEs, URR REGISTER REQUEST message format 600A includes a mobile identity IE, a GSM RR State IE, a GPRS Class Capability IE, a Cell Identifier List IE, a C1 List IE, an AP Identifier IE, and an AP Location IE. The mobile identity IE is mandatory and uses IMSI or IMEI if IMSI is not available. The GSM RR State IE is included to indicate the current GSM RR entity state. The GPRS Class Capability IE is included to indicate the GPRS Class capability of the MS. The Cell Identifier List IE is included if valid GSM cell information is available to the UMA RR entity. Within this IE, the Cell Identification Discriminator field shall be 0000 indicating the Cell Global Identification (CGI) format is used to identify the cells. The C1 List IE is present only if the “cell identifier list” IE is present. It contains the path loss criterion parameter C1 of each cell in the “Cell Identifier List” IE. The AP Identifier IE contains the MAC address of the unlicensed interface of the AP through which the MS is registering with the UNC. If the AP location is available, the MS can send corresponding information identifying the location of the AP via the AP Location IE, such as street address, latitude and longitude, etc.

[0150] URR REGISTER REQUEST message format 600B provides similar information in another format. In addition to the basic IEs, this message format includes a the following IEs. The UMA Release Indicator IE is used to identify the UMA Release supported. The UMA Classmark IE is used to provide the network with information concerning aspects of both the licensed and unlicensed radio interfaces, as well as the support for RTP redundancy of the MS equipment. The AP Radio Identity IE and the MS Radio Identity IE are used for transmission of a Bluetooth Device Address (BD_ADDR) or WLAN MAC address for the AP and MS, respectively. The GSM RR State IE is used to indicate the state of the GSM RR entity when the MS is registering for UMA service. The Coverage Indication IE is used to indicate the presence of GSM coverage at the current MS location.

[0151] A Cell Identity IE shall be included if the MS is in an area with GSM coverage. The Cell Identity value is retrieved from the GSM system information. The most recent Location Area Identification shall be included in the Location Area Identification IE if available in the MS. Similarly, the Routing Area Code (RAC) IE shall be included with a corresponding RAC value if available in the MS. The Geographical Location IE is a variable length IE providing an estimate of a geographic location of a target MS. The AP Location IE is used to indicate the location of the MS or AP (serving the MS) to the network.

[0152] A Register Reject Cause IE shall be included if the MS reattempts a URR Register Request after failing to connect to a serving UNC, along with a Redirection Counter IE. The conditional Last UNC SGW IP Address IE shall be included if the conditional IE Serving UNC SGW FQDN IE is not included. One of these IEs shall be included if a Register Reject Cause IE is included. Similarly, one of the conditional Last UNC IP Address IE or IE Serving UNC FQDN IE shall be included if a Register Reject Cause IE is included.

[0153] The AP Service Name IE shall be included if the MS connect via an AP over an unlicensed radio link. The value for this IE will be either the SSID or the PAN Service Name of the unlicensed AP being used. The MS shall include a Registration Indicators IE when attempting to register to a Default UNC. A UMA PLMN List IE shall be included only when attempting to register with the Default UNC and if no more PLMNs can be selected from the UMA PLMN List received from the Default UNC.

[0154] In addition to the foregoing registration content, the URR REGISTER REQUEST message may further include a reason for the connection and information about transmitting base stations that are within range (not shown). In a GSM system, this information is labeled Cell-Info and includes CGI and (optionally) C1 values. In one embodiment, only a single CGI is reported by the MS, representing the GSM cell that the MS has selected using its normal GSM cell selection procedures. This single cell has been selected by the MS to be the "best" GSM cell. Typically, to develop such values, the MS will scan certain designated frequencies to find broadcast channel (BCH) transmissions. The BCH will identify the transmitting base station and contain information about random access and traffic channels that are used by the particular base station. The MS can record the base station identities and measure the quality of the BCH signal as it is received. In GSM systems, the RXLEV (Received Signal Level) is typically measured but other quality measures may be used instead of, or in addition to the RXLEV, including signal to noise ratios, bit error rates, RSSI (Received Signal Strength Indicator) and signal propagation delays.

[0155] The UNC evaluates the received information about location and selects the appropriate UNC for the MS. This selection may be maintained for as long as the MS remains connected to the same AP. As mentioned above, there are a variety of different ways to select the appropriate UNC. In one embodiment the UNC maps the identification of the AP to a location, to a corresponding MSC and then to a corresponding UNC. In yet another embodiment, the UNC has no location information about base stations or the AP but it has a prior registration from the AP that included location information and selects a UNC on that basis.

[0156] In the simplest case, the registration request will be honored by the UNC to which it was submitted by having that UNC return a URR REGISTRATION ACK (knowledge)

message **602**, an exemplary format **602A** of which is shown in FIG. **8A**. Optionally, the message is referred to as a URR REGISTRATION ACCEPT message. One embodiment of a URR REGISTRATION ACCEPT message **602C** is shown in FIG. **8C**.

[0157] The information elements of URR REGISTRATION ACK message format **602A** includes the basic IEs (e.g., Protocol Discriminator, Skip Indicator, Message Type, and UCI), as well as a UMA System Information IE, a GPRS Uplink IP address, a GPRS Uplink UPD port, an Up Parameter Configuration IE, and a Status IE. Details of the formatting of one embodiment of the UMA System Information IE are shown in FIG. **8B**. Details of the various fields shown in the UMA System Information IE of FIG. **8C** are shown below.

GLIR—GSM Location Information Request	
0	GSM location information not requested
1	GSM location information requested
ATT—Attach/detach allowed	
0	IMSI attach/detach not allowed in UMA cell
1	MSs in the UMA cell shall apply IMSI attach and detach procedure
TI804—Timer value	
000	0 second, i.e., immediate access mode switching upon receipt of UMA-LINK-DETACH message or link loss
001	5 seconds
010	10 seconds
011	15 seconds
100	20 seconds
101	25 seconds
110	30 seconds
111	35 seconds
UMA-CELL-RESELECT-HYSTERESIS	
000	0 dB RxLev hysteresis
001	2 dB RxLev hysteresis
010	4 dB RxLev hysteresis
011	6 dB RxLev hysteresis
100	8 dB RxLev hysteresis
101	10 dB RxLev hysteresis
110	12 dB RxLev hysteresis
111	14 dB RxLev hysteresis
T3212 - Periodic Location Update timer	
The T3212 timeout value field is coded as the binary representation of the timeout value for periodic updating in decihours. Range: 1 to 255 The value 0 is used for infinite timeout value, i.e. periodic updating shall not be used within the UMA cell	
EC—Emergency Call Allowed	
0	Emergency call allowed in the UMA cell to all MSs
1	Emergency call not allowed in the UMA cell except for the MSs that belong to one of the classes between 11 to 15
AC CN—Access Control Class N	
For a MS with AC C = N access is not barred if the AC CN bit is coded with a '0'; N = 0, 1, . . . , 9, . . . , 15	
TI 811 - UMA Channel Activation timer	
The TI 811 value field is coded as the binary representation of the timeout value in 100 ms resolution. Range: 1-255 (100 ms to 25.5 sec)	
TI 900 - GSM to URR HANDOVER supervision timer	
The TI 900 value field is coded as the binary representation of the timeout value in 100 ms resolution. Range: 11-255 (1.1 sec to 25.5 sec)	

-continued

UMA-BAND

0000	P-GSM 900
0001	E-GSM 900
0010	R-GSM 900
0011	DCS 1800
0100	PCS 1900
0101	GSM 450
0110	GSM 480
0111	GSM 850

All other values are reserved
 ECSCM—Early Classmark Sending Mode, control the “early classmark sending” behavior

0	Hold the URR CLASSMARK CHANGE message until the first downlink message is received
1	Send the URR CLASSMARK CHANGE message as early as possible after UMA RR connection is established GPRS Ind—GPRS Service Availability

0	GPRS service not available in the UMA cell
1	GPRS service supported in the UMA cell

UMA-GPRS-CELL-RESELECT-HYSTERESIS

000	0 dB RxLev hysteresis
001	2 dB RxLev hysteresis
010	4 dB RxLev hysteresis
011	6 dB RxLev hysteresis
100	8 dB RxLev hysteresis
101	10 dB RxLev hysteresis
110	12 dB RxLev hysteresis
111	14 dB RxLev hysteresis

NMO—Network Mode of Operation. This field is meaningful only if “GPRS Ind” flag is set to 1

00	Network Mode of Operation I
01	Network Mode of Operation II
10	Network Mode of Operation III
11	Reserved

UMA-RAC - Routing Area Code of the UMA cell, see GSM03.03.
 This field is meaningful only if “GPRS Ind” flag is set to 1

[0158] The Up Parameter Configuration IE enables a UNC to configure Up interface parameters such as timers, retry counters, etc. The Status IE provides an indication from the UNC on whether location services are available (based on knowledge of AP’s geographical location). This can be used to trigger an icon or other display on the MS. In one embodiment the possible values are:

0	Location Services are Available
1	Location Services are Not Available

[0159] In general, URR REGISTER ACCEPT message format **602C** includes similar information provided in a different format. In addition to the basic IEs, the message format includes the following IEs. The Cell Identity IE and the Location Area Identification IE contain information similar to that discussed above for the URR REGISTER REQUEST message format **600B**. The UNC Control Channel Description IE is used to provide various information about the UMA service. The TU3910, TU3906, TU3920, TU4001, and TU4003 Timer IEs are used for various timer purposes, further details of which are discussed in the UMA Protocols Stage 3 specification. The UMA Band IE includes a coded value identifying the applicable band for GSM service. The UNC Cell Description IE is used to provide a minimum description of a

UMA cell. The Location Status IE is used to indicate whether the UNC is able to identify the location for the specific MS. The UMA Service Zone IE is included if the network is configured with UMA Service Zone information and contain information about the HPLMN.

[0160] If the network decides to reject the registration from the MS, the UNC will return an URR REGISTER REJECT message **604** to the MS, as depicted in the message sequence shown in FIG. 6B. A URR REGISTER REJECT/REDIRECT Messageformat **604A** that is employed in one embodiment of URR REGISTER REJECT message **604** is shown in FIG. 9A. In addition to the basic IEs, message format **604A** includes a UMA RR Cause IE, and optional Redirected UNC Address IE and Redirected SGW (Security Gateway) Address IEs. The RR Cause IE contains a value that is used to specify a reason for the rejection, such as Network Congestion, AP not allowed, Location not allowed, IMSI not allowed, etc.

[0161] A URR REGISTER REJECT message format **604B** shown in FIG. 9B may also be employed under an embodiment that uses separate URR REGISTER REJECT and URR REGISTER REDIRECT messages. The additional IEs in this message format include a Register Reject Cause IE that contains a lookup value from which a reason for the rejection can be identified via a corresponding lookup table (not shown). The TU3907 Timer IE is used to specify the minimum period of time an MS should wait before attempting Registration at the current UNC. The Location Black List Indicator IE shall be included if the Register Reject Cause ‘Location not allowed’ is returned to the MS, and is used to indicate which part of the Location Area Identification is to be added to the Location Black List. The Location Area Identification IE is used to provide an unambiguous identification of location areas within the area covered by the GSM system.

[0162] The optional Redirected UNC Address IE and Redirected SGW Address IEs in message format **604A** may be employed for redirection purposes. For example, a registration message sequence that involves UNC redirection is shown in FIG. 6C. Redirection may be applicable under various circumstances. For example, the location of a given AP might be moved, such that it is more advantageous to access the network via another AP. Similarly, an MS may contain information instructing it to access a default UNC based on a “normal” location of a subscriber—if the subscriber location is different, the default UNC may not be appropriate.

[0163] Referring to FIG. 6C, at step E a determination to redirect the session to UNC **2** is made by the serving UNC (e.g., UNC **1**) and/or the network in view of applicable criteria as described above. At step F, UNC **1** acknowledges the registration request and sends a URR REGISTER REJECT message **604'** that contains an address for the selected UNC (UNC **2**) and/or the address for the security gateway associated with the UNC to MS **102**. The address(es) may be in the form of a FQDN (Fully Qualified Domain Name) or in another form, such as an IP address. In another embodiment, a separate URR REGISTER REDIRECT message is used, as shown by a URR REGISTER REDIRECT message format **604C** in FIG. 9C. In addition to the basic IEs, this message format will include one of a Serving UNC SGW IP Address IE or Serving UNC SGW FQDN IE, one of a Serving UNC IP Address IE or Serving UNC FQDN IE, a Serving UNC Table Indicator IE, an optional Serving UNC Port Number IE, and a conditional UMA PLMN List IE.

[0164] At step G, the MS performs a DNS query for the selected UNC. It may also release the TCP connection to the

first UNC (UNC 1) and initiate a connection to the second UNC's IP address or SGW address. Accordingly, at step H, a TCP connection is established between the MS and the new UNC (UNC 2) to which the MS was redirected. At step H, the connection is established between the MS and the second UNC. The IPsec tunnel with the original UNC may be reused or a new one may be established (not shown).

[0165] At step I, the MS may send a second registration request message to the second UNC, as depicted by a URR REGISTER REQUEST message 600'. In a URR-REGISTER-REQUEST type of message, a reason field may carry a value for redirection instead of a normal connection. The information in the registration request may cause the new UNC to apply information that it has to further redirect the MS. Because it is closer to the location of the AP, it may have more or better information on the AP, nearby base stations or network resource allocations and may then further redirect the MS. The reason field may be used to inform the MS about the number of redirections. It may be used to limit the total number of redirections that a MS may experience at a single AP to one or two or any other number.

[0166] At step J, the connection with the UNC continues along its normal course. This may include registration acknowledgments, call setup and teardown, and any of a variety of different supported voice or data services, including security measures.

Registration Update

[0167] Under various use scenarios, a need to perform a registration update may result. Generally, a registration update procedure may be initiated by an MS (more common) or the network (less common). For example, after an MS has successfully registered to an UNC, the MS may employ a registration update procedure to inform the UNC if the AP (via which the MS is accessing the network) or the overlapping GSM coverage has changed.

[0168] An example of messaging employed to facilitate an MS-initiated registration update is shown in FIG. 10A. At step A, MS 102 has established a connection with UNC 140 in the normal manner described above. At step B, the MS obtains valid cell information. For example, the MS receives information for a local GSM cell. At step C, the MS sends a URR REGISTER UPDATE UPLINK message 1000 to the UNC. The URR REGISTER UPDATE UPLINK message is sent by an MS to a UNC to update registration parameters.

[0169] FIG. 11A shows one embodiment of URR REGISTER UPDATE UPLINK message format 1000A. In addition to the basic IE's, this message includes a Reason IE, a Cell Identifier List IE, a C1 List IE, an AP identifier IE, and an AP Location IE. The Reason IE is a mandatory IE that specifies whether the reason for the update is due to a cell update or an AP update. A Cell Identifier List IE will be included if GSM cell information (available to the UMA RR entity) has changed since the last registration or update. Within this IE, the Cell Identification Discriminator field shall be 0000 indicating the Cell Global Identification (CGI) format is used to identify the cells. The C1 List IE is present only if the Cell Identifier List IE is present. It contains the path loss criterion parameter C1 of each cell in the Cell Identifier List IE. The AP Identifier IE will be included if the AP through which the MS is communicating with the UNC has changed since the last registration or update. The AP Identifier is the MAC address of the unlicensed interface of the AP through which the MS is communicating with UNC.

[0170] A message format 1000B illustrative of another embodiment of a URR REGISTER UPDATE UPLINK message is shown in FIG. 11B. This message format includes an AP Radio Identity IE, a Coverage Indication IE, a Cell Identity IE, a Location Area Information IE, a Routing Area Code IE, a Geographical Location IE, and an AP Location IE, each of which are employed for a similar manner discussed above.

[0171] When receiving a URR REGISTER UPDATE UPLINK message, the network may either accept or reject the registration update, or redirect the MS to another UNC. In one embodiment, if there are not any actions to be taken by the UNC (e.g., a change in the access elements for the MS), the UNC simply accepts the registration update parameters with no reply message. In this case, the URR REGISTER UPDATE UPLINK message is merely informative. If the network rejects the registration update, the network sends a URR DEREGISTER message to the MS. Details of a URR DEREGISTER message are discussed below. Additionally, depending on the registration update information that is sent in the message, the UNC may redirect the MS to another MS using a URR REGISTER REDIRECT message, as depicted by a URR REGISTER REDIRECT message 604' at step D in FIG. 10A. In response, normal connection procedures would be established with the new UNC to which the MS was redirected, as shown in a step E.

[0172] FIG. 10B shows various message transfers that may be performed in connection with a network-initiated registration update. As before, at step A MS 102 has established a connection with UNC 140 in the normal manner. At step B, a network-initiated update event occurs. At step C, the UNC sends a URR REGISTER UPDATE DOWNLINK message 1002, respective embodiments of which are detailed in message formats 1002A and 1002B of FIGS. 12A and 12B. The URR REGISTER UPDATE DOWNLINK message format 1002A includes a Redirected UNC Address IE, a Redirected SGW Address IE, and a Status IE. The Status IE provides an indication from the UNC on whether location services are available (based on knowledge of the AP's geographical location). This can be used to trigger an icon or other display on the MS. In one embodiment, possible values are:

0	Location Services are Available
1	Location Services are Not Available

[0173] Many IEs of URR REGISTER UPDATE DOWNLINK message format 1002B are analogous to like-named IEs in URR REGISTER ACCEPT message format 602C. These include a Cell Identity IE, a Location Area Identification IE, a UNC Control Channel Description IE, TU3910, TU3906, TU3920, TU4001, and TU4003 Timer IEs, UNC Cell Description IE, and a Location Status IE

[0174] Under some conditions, it may be advantageous to have an MS be redirected to re-register with a different UNC in view of the updated registration information. If the network decides to redirect the MS to another UNC, it will send a URR REGISTER REDIRECT message to the MS, as depicted by a URR Register Redirect message 604B at step D. At step E, normal connection procedures are performed to establish a connection with the UNC to which the MS is redirected.

Deregistration

[0175] In general, deregistration may be initiated by an MS (e.g., when deregistering an existing connection) or the net-

work via an appropriate UNC. For instance, the MS should attempt to perform a deregister procedure before leaving an AP, which is facilitated by sending a URR DEREGISTER message from the MS to the UNC. Similarly, the UNC may initiate deregistration of the MS at any time by sending a URR DEREGISTER message to the MS.

[0176] Exemplary URR DEREGISTER message formats **1300A** and **1300B** are shown in FIGS. **13A** and **13B**. URR DEREGISTER message format **1300A** includes a URR cause IE in addition to the basic IEs. A lookup table containing an exemplary set of values for the URR cause IE are shown in FIG. **14**. Based on the URR cause value, a lookup into the URR cause lookup table may be performed to identify the reason for the deregistration. Meanwhile, URR DEREGISTER message format **1300B** includes a Register Reject Cause IE that is employed for a similar function. URR DEREGISTER message format **1300B** also includes a Location Black List Indicator IE and a Location Area Identification IE.

Channel Activation

[0177] Channel activation is used to establish a voice or circuit switched data bearer channel. FIG. **15** shows an exemplary message sequence performed in connection with channel activation. At step A, MS **102** has established a connection with UNC **140** in the normal manner. At step B, the UNC sends an URR ACTIVATE CHANNEL message **1500** to the MS. In response to receiving a URR ACTIVATE CHANNEL message, the MS attempts to establish a corresponding UMA voice bearer channel. If successful, the MS returns a URR ACTIVATE CHANNEL ACK(nowledge) message **1502**, as shown at step C. If the UMA voice bearer channel cannot be established, the MS returns a URR ACTIVATE CHANNEL FAILURE message **1504**, as shown at step C'. Upon successful activation, a URR ACTIVATE CHANNEL COMPLETE message **1506** is sent by the UNC to the MS to indicate that the established voice channel between the MS and the UNC is now ready for use, as shown at step D.

[0178] FIG. **16A** shows details of one embodiment of a URR ACTIVATE CHANNEL message format **1500A**. In addition to the basic IEs, this message format includes a Channel Mode IE, a UNC SDP IE, and a CIPHER Mode Setting IE. In one embodiment, the Channel Mode IE specifies the following channel modes:

[0179] 0000 0001 speech full rate or half rate version 1

[0180] 0010 0001 speech full rate or half rate version 2

[0181] 0100 0001 speech full rate or half rate version 3 (AMR version 1)

[0182] The UNC SDP (Session Description Protocol) IE is used for specifying information used to implement the uplink (from MS to UNC) portion of the voice bearer channel. For example, this information may include the network address (IP address), the transport address (port), the transport protocol (e.g., RTP over UDP), the sample size (e.g., 20 ms) and the payload type (among other things). In one embodiment the format of this IE's values are defined in RFCs 2327, 3551 and 3267. The use of a single IE to contain this information is merely exemplary, as such information may also be provided via separate IEs. The optional CIPHER Mode Setting IE appears when the ciphering mode is changed after the MS has switched to the assigned channel. If this information element is omitted, the mode of ciphering is not changed after the channel assignment procedure.

[0183] FIG. **16B** shows another embodiment of a URR ACTIVATE CHANNEL message format **1500B**. This mes-

sage format includes a Channel Mode IE, a Sample Size IE, an IP Address IE, an RTP UDP Port IE, a Payload Type IE, a Multi-rate Configuration IE, an RTP Redundancy IE, and a RTCP UDP Port IE. The RTP UDP Port IE identifies the Real Time Protocol UDP port. The RTCP UDP Port IE identifies the Real Time Control Protocol UDP port. The Payload Type IE is included when the speech codec signaled uses a dynamically assigned Payload Type.

[0184] FIG. **17A** shows one embodiment of a URR ACTIVATE CHANNEL ACK message format **1502A**. In addition to the basic IEs, this message format includes an MS SDP IE, an optional Cell Identifier List IE, and a conditional C1 list IE. The MS SDP IE is used for specifying information used to implement the downlink (from UNC to MS) portion of the voice bearer channel. This IE is substantially analogous to the UNC SDP IE discussed above, except that the port and address information now pertains to the MS rather than the UNC. The Cell Identifier List IE will be included if valid GSM cell information is available to the UMA RR entity. Within this IE, the Cell Identification Discriminator field is set to 0000 to indicate the Cell Global Identification (CGI) format is used to identify the cells. The C1 List IE is present only if the Cell Identifier List IE is present. It contains the path loss criterion parameter C1 of each cell in the Cell Identifier List IE.

[0185] FIG. **17B** shows another embodiment of a URR ACTIVATE CHANNEL ACK message format **1502B**. In addition to the basic IEs, this message format includes an RTP UDP Port IE, a Sample Size IE, a Payload Type IE, and an RTCP UDP Port IE.

[0186] FIG. **18A** shows one embodiment of a URR ACTIVATE CHANNEL FAILURE message format **1504A**. The additional IEs include a UMA RR Cause IE, an optional Cell Identifier List IE, and a conditional C1 List IE. The UMA RR Cause IE contains a coded cause of the failure. Meanwhile, the Cell Identifier List IE and a conditional C1 list IE are the same as above. The URR ACTIVATE CHANNEL FAILURE message format **1504B** of FIG. **18B** also employs a UMA RR Cause IE.

[0187] FIGS. **19A** and **19B** show respective embodiments of URR ACTIVATE CHANNEL COMPLETE message formats **1506A** and **1506B**. As depicted, each of these message formats only contains their basic IEs, wherein the URR ACTIVATE CHANNEL COMPLETE message is identified by the Message Type values.

Handovers

[0188] There are two primary types of handovers supported by the network: Handover to UMAN, and handover from UMAN. During a handover to UMAN, network access to an MS is handed over from licensed-based radio access network (e.g., GERAN) to UMAN network infrastructure. During a handover from UMAN, the MS access is handed over from the UMAN network infrastructure to the licensed-based radio access network.

Handover to UMAN

[0189] An exemplary message sequence corresponding to a handover to UMAN is shown in FIG. **20**. Step A represents an existing connection that has previously been established, such as by using the technique shown in FIG. **6A**. At step B, a URR HANDOVER ACCESS message **2000** is sent from MS **102** to UNC **140** in response to a corresponding handover

order made by the licensed network. If non-signaling mode is indicated in the Channel Mode IE, the UNC initiates Traffic channel assignment, as depicted at step C. If the traffic channel assignment is successful, the MS will return a URR HANDOVER COMPLETE message **2002** to the UNC, as depicted at step D.

[0190] Respective embodiments of URR HANDOVER ACCESS message formats **2000A** and **2000B** are shown in FIGS. **21A** and **21B**. In addition to the basic IEs, message format **2000A** includes a HANDOVER COMMAND message IE, while message format **2000B** includes an analogous Handover to UMAN Command IE. Each of these IEs contains a complete HANDOVER COMMAND layer 3 message (as described below) to provide handover reference used by the UMA Controller for access identification.

[0191] FIGS. **22A** and **22B** shows respective embodiment of URR HANDOVER COMPLETE message formats **2002A** and **2002B**. Each of these message formats includes their basic IEs, and is identified by the value of the message type.

Handover from UMAN

[0192] A handover from the UMAN is performed to transfer a connection between an MS and the UMAN to another radio access network (e.g., GERAN). Message sequences corresponding to successful and unsuccessful handovers from UMAN are respectively shown in FIGS. **23A** and **23B**. The handover from UMAN procedure begins with a connection established and the MS in a dedicated state, as shown at step A. In response to a URR UPLINK QUALITY INDICATION message **2300** received from the UNC at step B, or if the MS determines a handover is appropriate, the MS sends a URR HANDOVER REQUIRED message **2302** to the UNC at step C. The UNC then sends a URR HANDOVER COMMAND **2304** back to the MS at step D. If the handover from UMAN is unsuccessful, the MS returns a URR HANDOVER FAILURE message **2306**, as shown at step E in FIG. **23B**.

[0193] Details of one embodiment of a URR UPLINK QUALITY INDICATION message are shown in FIG. **24**. The message may include various information indicative of uplink quality of the bearer channel. The particular format of this information is dependent on the particular implementation.

[0194] FIG. **25A** shows details of one embodiment of a URR HANDOVER REQUIRED message format **2302A**. In addition to the standard IEs, this message includes a Channel Mode IE, and Cell Identifier List, and a C1 List. These latter two IEs are the same as discussed above. In one embodiment, the Channel Mode IE defines the channel mode as specified by GSM04.08.

[0195] FIG. **25B** shows details of another embodiment of a URR HANDOVER REQUIRED message format **2302B**. This message format includes a GERAN Cell Identifier List IE, a GERAN Received Signal Level List IE, a UTRAN Cell Identifier List IE, and a UTRAN Received Signal Level List IE. The GERAN Cell Identifier List IE contains information identifying applicable GERAN cells. The GERAN Received Signal Level List IE includes information indicating the received signal level for each GERAN cell. Similarly, the UTRAN Cell Identifier List IE and a UTRAN Received Signal Level List IE respectively contain information identifying applicable UTRAN cells and their received signal levels.

[0196] FIGS. **26A** and **26B** show details of one embodiment of a URR HANDOVER COMMAND message format **2304A**. This message format is compiled based on the HAN-

DOVER COMMAND message format defined in GSM 04.08/Release 98, with all optional IEs not applicable to the UMA to GSM handover removed. This message format includes a number of IEs in addition to the basic IEs; selected IEs are detailed below.

[0197] The Synchronization Indication IE is used to identify what type of synchronization is applicable. If this information element does not appear, the assumed value is "non-synchronized". Four types of handover defined in section 3.4.4.2 of GSM04.08: Non-synchronized, Synchronized, Pre-synchronized, and Pseudo-synchronized. The UMA to GSM handover can be either a non-synchronized or pre-synchronized handover. Synchronized handover and pseudo-synchronized handover require the MS to calculate the timing advance based on known one way delay with the old BTS and the Observed Time Difference between the old and new BTS (more description in annex A of GSM05.10). For a UMA to GSM handover, such variables are unknown. The ROT field of this IE shall be set to 0 so that the MS does not need to report its Observed Time Difference in the HANDOVER COMPLETE message.

[0198] Mode of the First Channel IE: If this information element is not present, the channel mode of the previously allocated channel shall be assumed.

[0199] Frequency Channel Sequence, Frequency List, Frequency short list and Mobile Allocation, after time IEs: If at least one of the channel descriptions for after time indicates frequency hopping, one of the following information elements will be present:

[0200] Frequency Channel Sequence, after time;

[0201] Frequency list, after time;

[0202] Frequency Short List, after time;

[0203] Mobile Allocation, after time.

[0204] If neither of the Channel Description IEs indicate frequency hopping, if they are not required for the decoding of Channel Description IEs for before time, and if any of the four information elements are present, they will be considered as IEs unnecessary in the message.

[0205] The Frequency Channel Sequence IE shall not be used unless all the ARFCNs that it indicates are in the P-GSM band. The starting time IE is included when the network wants the MS to change the frequency parameters of the channels more or less at the moment a change of channel occurs. In this case a number of information elements may be included to give the frequency parameters to be used before the starting time. The starting time IE refers to the new cell time. If the starting time IE is present and none of the information elements referring to before the starting time are present, the MS waits and accesses the channels at the indicated time. If the starting time IE is present and at least one of the information elements referring to before the starting time is present, the MS does not wait for the indicated time and accesses the channel using the frequency parameters for before the starting time. If the starting time IE is not present and some of the information elements referring to before the starting time are present, these information elements shall be considered as IEs unnecessary in the message.

[0206] If the description of the first channel, before time IE is not present, the channel description to apply for before the time, if needed, is given by the description of the first channel, after time IE. If the description of the second channel, after time IE is present, the description of the second channel, before time IE not present, and a description of the configuration for before the time needed, the channel configuration

before the starting time is nevertheless of two traffic channels, and the channel description to apply to the second channel before the starting time is given by the description of the second channel, after time IE.

[0207] If the starting time IE is present and at least one of the channel descriptions for before the starting time indicates frequency hopping, one and only one of the following information elements may be present and applies before the starting time to all assigned channels:

[0208] Mobile Allocation, before time IE;

[0209] Frequency Short list, before time IE;

[0210] Frequency list, before time IE;

[0211] Frequency channel sequence, before time IE.

[0212] If the starting time IE is present and at least one of the channel descriptions for before the starting time indicates frequency hopping, and none of the above mentioned IE is present, a frequency list for after the starting time must be present, and this list applies also for the channels before the starting time.

[0213] Reference cell frequency list: If any of the mobile allocation information elements are present, then the cell channel description IE must be present. It is used to decode the mobile allocation IEs in the message. In addition, if no information elements pertaining to before the starting time is present in the message, the frequency list defined by the cell channel description IE is used to decode the mobile allocation IEs in later messages received in the new cell until reception of a new reference cell frequency list or the new cell is left.

[0214] The Timing Advance IE element will be present if the "synchronization indication" element indicates a pre-synchronized handover. If not included for a pre-synchronized handover, then the default value as defined in GSM 05.10 shall be used. For other types of handover it shall be considered as an unnecessary information element.

[0215] The CIPHER Mode Setting IE: If this information element is omitted, the mode of ciphering is not changed after the MS has switched to the assigned channel. The Multi Rate Configuration IE appears if the Mode of the First Channel IE indicates a multi-rate speech codec, and if the assigned configuration is new, i.e. it is different from the MultiRateConfiguration used in the serving cell. If the Mode of the First Channel IE indicates a multi-rate speech codec, and this IE is not included, then the MS shall assume that the MultiRateConfiguration has not changed.

[0216] FIG. 26C shows an embodiment of a URR HANDOVER COMMAND message format 2304B. In addition to the basic IEs, this message format includes a Handover From UMAN Command IE. If the target radio access technology is GERAN, the value part of the Handover From UMAN Command IE is coded as the HANDOVER COMMAND message specified in 3GPP TS 44.018, Rel-4: "Mobile radio interface layer 3 specification, Radio Resource Control (RRC) protocol."

[0217] FIG. 27A shows details of one embodiment of a URR HANDOVER FAILURE message format 2406A. In addition to the basic IEs, this message includes a UMA RR Cause IE, with an applicable value as defined in the value table of FIG. 14. The URR HANDOVER FAILURE message format 2604B shown in FIG. 27B employs an RR Cause IE for a similar purpose.

Release of URR

[0218] Release of the URR connection and signaling may be initiated by the MS or the UNC. FIG. 28 shows a URR

release that is initiated by an MS. At step A, a connection between MS 102 and UNC 140 is established, with the MS operating in the dedicated state. To release the URR, the MS sends a URR CLEAR REQUEST message 2800 to the UNC at step B. Details of one embodiment of the URR CLEAR REQUEST message are shown in FIG. 29. This message format includes the basic IEs, with the message identified by the message type value. In response to the URR CLEAR REQUEST message, the UNC sends a release request 2802 to the core network to release resources used for the URR connection, as shown at step C. In response, the core network will initiate the release of the appropriate resources for the URR connection. The release typically results in the sequence shown in FIG. 30.

[0219] FIG. 29A shows an embodiment of a URR RR CLEAR REQUEST message format 2800A, while FIG. 29B shows an embodiment of a URR CLEAR REQUEST message format 2800B. URR RR CLEAR REQUEST message format 2800A just includes its basic IEs and is identified by its message type value. The URR CLEAR REQUEST message format 2800B further includes an RR Cause IE.

[0220] FIG. 30 shows a message sequence corresponding to an URR release that is either initiated by the UNC or results when the UNC receives the URR CLEAR REQUEST message. As before, at step A a connection between MS 102 and UNC 140 is established, with the MS operating in the dedicated state. At step B, the UNC sends a URR RR RELEASE message 3000 (alternatively called a URR RELEASE message) to the MS. (In further detail, the UNC will typically receive the URR CLEAR REQUEST, sends a Clear Request message to the MSC, then the MSC releases the session, resulting in the UNC sending the URR RELEASE message.) In response, the MS returns a URR RR RELEASE COMPLETE message 3002 (alternatively called a URR RELEASE COMPLETE message) to the UNC at step C. In addition the MS releases all URR resources and any traffic channel resources and then enters a URR-IDLE state.

[0221] FIGS. 31A and 31B show details of respective embodiments of URR (RR) RELEASE message formats 3000A and 3000B. In addition to the basic IEs, each of these message formats includes a UMA RR Cause IE and an optional GPRS Resumption IE. The UMA RR Cause IE is used to define the reason for the release, via a corresponding value defined in the table of FIG. 14. The GPRS (General Packet Radio Service) Resumption IE is used to indicate whether the UNC has successfully resumed a GPRS session that the MS suspended when it started the URR session.

[0222] FIGS. 32A and 32B show details of respective embodiments of URR (RR) RELEASE COMPLETE message formats 3002A and 3002B. Each of these message formats includes its basic IEs, with the message identified by the message type value.

Paging Messages

[0223] The UNC initiates paging when it receives a PAGING REQUEST message over the A-interface or a Paging CS message over the Gb-interface. The MS to be paged is identified by the identity received in the request. An exemplary exchange of paging messages is shown in FIG. 33. The sequence starts with UNC 140 sending a URR PAGING REQUEST message 3300 to MS 102 at step A. At step B, the MS returns a URR PAGING RESPONSE message 3302. This message is sent from the MS to the UNC as the first message

over the newly established UMA RR session in response to the URR PAGING REQUEST message.

[0224] FIGS. 34A and 34B show details of respective embodiments of URR PAGING REQUEST message formats 3300A and 3300B. In addition to their basic IEs, each of these message formats includes a Channel Needed IE (used to indicate whether the page is for signaling session establishment or call establishment), and a Mobile Identity IE (used to identify the MS).

[0225] FIGS. 35A and 35B show details of respective embodiments of URR PAGING RESPONSE message formats 3302A and 3302B. In addition to their basic IEs, each of these message formats includes a Ciphering Key Sequence Number IE, a Channel Needed IE, and a Mobile Identity IE. MG: The purpose of the Ciphering Key Sequence Number information element is to make it possible for the network to identify the ciphering key K_c which is stored in the mobile station without invoking an authentication procedure. K_c gets generated and stored when the MS is authenticated (challenged with a random number) by the network. While K_c is not used to encrypt the call when in UMA mode, it may be necessary if the call gets handed over to GSM. If the network does not authenticate every call (e.g., every 3 or 4 calls), the Ciphering Key Sequence Number IE provides a way to select a stored K_c value. URR PAGING RESPONSE message format 3302B further includes an Establishment Cause IE, which is used by the MS to indicate the type of the transaction being initiated to the network via a coded value which may be identified by a corresponding lookup table.

Classmark Messages

[0226] Classmark messages are used to enable a UNC to gain information about an MS's capabilities. The classmark interrogation procedure may be initiated when the MS has established a dedicated connection (i.e., the MS is in URR-DEDICATED mode), as shown at step A in FIG. 36. As shown at step B, the UNC initiates the classmark interrogation procedure by sending a URR CLASSMARK ENQUIRY message 3600 to the MS. In response, the MS returns a URR CLASSMARK CHANGE message 3602 at step C.

[0227] FIG. 37A shows details of one embodiment of a URR CLASSMARK ENQUIRY message format 3600A. The illustrated message format includes the basic IEs, with the message being identified by the message type value. In addition to the basic IEs, the URR CLASSMARK ENQUIRY message format 3600A of FIG. 37B includes a Classmark Enquiry Mask IE. This IE defines the information to be returned to the network. The bit mask defines the specific information to be returned, such as UTRAN specification information and/or requests the sending of the URR CLASSMARK CHANGE message.

[0228] FIGS. 38A and 38B show details of respective embodiments of URR CLASSMARK CHANGE message formats 3602A and 3602B. In addition to their basic IEs, each of these message formats includes a Mobile State Classmark IE, and an Additional Mobile Station Classmark Information IE. Under message format 3602A, the Mobile State Classmark IE includes the Classmark 2 information corresponding to the frequency band currently being used by the GSM RR entity, as defined by GSM04.08. In one embodiment, an Additional Mobile Station Classmark Information IE will be included if the CM3 bit in the Mobile Station Classmark IE is set to 1. This IE provides additional MS capabilities for Classmark 3 as defined by GSM04.08. The Mobile State Classmark

IE and Additional Mobile Station Classmark Information IE of message format 3602B are encoded per the 3GPP TS 24.008, Rel-4 specification: "Mobile radio interface layer 3 specification."

UNC Architecture

[0229] A block diagram illustrating a high level architecture corresponding to one embodiment of a UNC is shown in FIG. 39. At the heart of the UNC architecture is an indoor network controller (INC) 3900. In general, the INC performs operations synonymous to those described above for the UNC. However, as shown in the illustrated UNC architecture, an integrated security gateway server 3902 is included, as well as a media gateway 3904 which is controlled by the INC. Accordingly, each of these elements is shown as a separate element that is employed to facilitate various aspects of the UNC operations described herein.

[0230] In general, the UNC may provide one or more communication ports to support communications between mobile stations and the UNC (e.g., via an AP 128 and broadband IP network 138 as shown in FIG. 1). For example, in the illustrated embodiment of FIG. 39, security gateway server 3902 is coupled to IP network 138 via an IP port 3906. In addition, IP ports 3908 and 3910 are used to connect INC 3900 and media gateway 3904 to the security gateway server.

[0231] The security gateway server 3902 performs security and authentication services. It may be an integrated unit (as shown), or may be a separate (physical) unit connected to the UNC via an appropriate communication link. Likewise, media gateway 3904, which serves as a media gateway for voice services provided by the core network, may comprise an integrated unit (as shown) or a separate unit connected to the INC and security gateway servers via appropriate communication links.

[0232] The INC 3900 includes resources to support (i.e., generate and process) the UP interface messages described herein. These resources are depicted as UP Interface (I/F) logic 3912. Similarly, INC 3900 includes SGSN interface logic 3914 to support communications with SGSN 114 via a Gb port 3916, and MSC interface logic 3918 to support communication with MSC 110 via an SS7 port 3920. Meanwhile, media gateway 3904 includes MSC interface logic 3922 to support communication with MSC 110 via a TDM port 3924. Each of UP interface logic 3912, SGSN interface logic 3914, and MSC interface logic 3918 and 3922 may be implemented via execution of software, built-in programmed hardware, or a combination of the two. For example, UP interface logic 3912 may be facilitated by executing one or more software modules on a processor, wherein the software modules are coded to generate and/or process URR messages.

[0233] In general, a UNC may be implemented by a single server, multiple distributed servers, and multiple clustered servers. For example, a single server 3926 may be employed for running various software applications to provide the various functions shown in the block diagram of the UNC architecture of FIG. 39. Optionally, some of the functions, such as the security gateway server functions and/or media gateway functions, may be provided by a separate server or servers. In yet another configuration, a blade server 3928 is employed. The blade server includes multiple server blades 3930 that are installed in a common rack or chassis, with each server blade functioning as a separate server, each with its own processor (s), memory, and network interfaces. In one embodiment, the functions provided by each of the security gateway server

3902, INC 3900, and media gateway 3904 are facilitated via execution of software applications and/or modules on respective server blades 3930.

Mobile Station Architecture

[0234] FIG. 40 shows a block diagram illustrating a high-level architecture for one embodiment of a mobile station. The architecture includes a processor 4000 coupled to a non-volatile memory 4002, a licensed RAN antenna sub-system 4004 and an unlicensed RAN antenna sub-system 4006. Non-volatile memory 4002 is used to store software/firmware instructions for performing various functions and operations described herein. These functions and operations are depicted licensed RAN interface logic 4008, WLAN interface logic 4010, and Up interface logic 4012.

[0235] Licensed RAN antenna sub-system 4004 and licensed RAN interface logic 4008 are employed to facilitate conventional licensed RAN operations. For example, in one embodiment the licensed RAN comprises a GSM network, and thus these components facilitate normal GSM network operations typically employed by GSM-based cellular devices and the like, which are well-known in the cellular communication art. Meanwhile, the unlicensed RAN antenna system 4006 and WLAN interface logic 4010 are used to support an unlicensed wireless channel (i.e., link) 136 with an access point 128 via which UMAN services may be accessed. In general, these blocks represent conventional components and logic employed to support communications over an unlicensed WLAN link. For example, these components are illustrative of components that may be employed to implement the Bluetooth lower layers shown in FIG. 3B for a Bluetooth link, or the 802.11 lower layers shown in FIG. 3C for an 802.11 link.

[0236] Up interface logic 4012 is used to provide the MS-side Up interface functions and operations described herein. This includes generating and processing various URR messages, as well as providing the various UP interface layers depicted in FIGS. 3A and 3D-F.

[0237] As discussed above, the various message formats depicted herein are exemplary. However, each message should include a basic set of information elements including a protocol discriminator, a skip indicator, and a message identity. The inclusion of an UCI information element as a basic IE is depicted in the exemplary message formats illustrated herein; however, the UCI IE or a similar IE for indicating whether a message is a first message, other message, or emergency-related is not required and this functionality may be facilitated by other means, such as by maintaining appropriate state information on the communicating devices (i.e., mobile stations and UNC's).

[0238] Under a proposed implementation, message delineation over a streaming transport (e.g., TCP) is performed by the underlying transport itself. Accordingly, there is not a need to include an information element specifying the length of a variable-length message format. However, this is not meant to be limiting, as the use of an information element for specifying the length of a message is contemplated by the inventors as another means for delineating streamed messages.

[0239] The formats of the various information elements is also merely exemplary. For example, a given set of information may be provided via a single IE or via multiple IEs.

Furthermore, the information contained in the IEs depicted herein may be arranged in other formats and/or grouped in alternate manners.

[0240] The means for facilitating various message generation and processing operations, as well as various aspects of the Up interface may include execution of software/firmware instructions on an appropriate processing element, such as, but not limited to, a processor, multiple processors, a multi-core processor, a microcontroller, etc. Thus, embodiments of this invention may be used as or to support instructions executed upon some form of processing core or otherwise implemented or realized upon or within a machine-readable medium. A machine-readable medium includes any mechanism for storing or transmitting information in a form readable by a machine (e.g., a computer). For example, a machine-readable medium can include a read only memory (ROM); a random access memory (RAM); a magnetic disk storage media; an optical storage media; and a flash memory device, etc. In addition, a machine-readable medium can include propagated signals such as electrical, optical, acoustical or other form of propagated signals (e.g., carrier waves, infrared signals, digital signals, etc.). For example, in one contemplated implementation, instructions embodied as software upgrades for facilitating UMA messaging may be downloaded to a mobile device via a wireless link, such as a UMAN or GSM link.

[0241] The above description of illustrated embodiments of the invention, including what is described in the Abstract, is not intended to be exhaustive or to limit the invention to the precise forms disclosed. While specific embodiments of, and examples for, the invention are described herein for illustrative purposes, various equivalent modifications are possible within the scope of the invention, as those skilled in the relevant art will recognize.

[0242] These modifications can be made to the invention in light of the above detailed description. The terms used in the following claims should not be construed to limit the invention to the specific embodiments disclosed in the specification and the drawings. Rather, the scope of the invention is to be determined entirely by the following claims, which are to be construed in accordance with established doctrines of claim interpretation.

APPENDIX I

Table Of Acronyms

AP	Access Point
ARFCN	Absolute RF Channel Number
ATM	Asynchronous Transfer Mode
ATM VC	ATM Virtual Circuit
BA	BCCCH Allocation
BAS	Broadband Access System
BB	Broadband
BCCH	Broadcast Common Control Channel
BRAS	Broadband Remote Access System
BSC	Base Station Controller
BSS	Base Station Subsystem
BSSGP	Base Station System GPRS Protocol
BSSMAP	Base Station System Management Application Part
BTS	Base Transceiver Station
CDMA	Code Division Multiple Access
CGI	Cell Global Identification
CIC	Circuit Identity Code
CLIP	Calling Line Presentation
CM	Connection Management
CPE	Customer Premises Equipment
CS	Circuit Switched

APPENDIX I-continued

Table Of Acronyms	
CVSD	Continuous Variable Slope Delta modulation
DSL	Digital Subscriber Line
DSLAM	DSL Access Multiplexer
DTAP	Direct Transfer Application Part
ETSI	European Telecommunications Standards Institute
FCAPS	Fault-management, Configuration, Accounting, Performance, and Security
FCC	US Federal Communications Commission
GERAN	GSM Edge Radio Access Network
GGSN	Gateway GPRS Support Node
GMM/SM	GPRS Mobility Management and Session Management
GMSC	Gateway MSC
GSM	Global System for Mobile Communication
GPRS	General Packet Radio Service
GSN	GPRS Support Node
GTP	GPRS Tunnelling Protocol
HLR	Home Location Register
IAN	Indoor Access Network (see also UMA Cell)
IAN-RR	Indoor Access Network Radio Resource Management
IBS	Indoor Base Station.
IBSAP	IBS Application Protocol
IBSMAP	IBS Management Application Protocol
IEP	IAN Encapsulation Protocol
IETF	Internet Engineering Task Force
IMEI	International Mobile Station Equipment Identity
IMSI	International Mobile Subscriber Identity
INC	Indoor Network Controller
INC	Indoor Network Controller
IP	Internet Protocol
ISDN	Integrated Services Digital Network
ISP	Internet Service Provider
ISP IP	Internet Service Provider's IP
IST	IAN Secure Tunnel
ISUP	ISDN User Part
ITP	IAN Transfer Protocol
LA	Location Area
LAI	Location Area Identification
LLC	Logical Link Control
MAC	Medium Access Control
MAP	Mobile Application Part
MDN	Mobile Directory Number
MG	Media Gateway
MM	Mobility Management
MM	Mobility Management
MS	Mobile Station
MSC	Mobile Switching Center
MSC	Mobile Switching Center
MSISDN	Mobile Station International ISDN Number
MSRN	Mobile Station Roaming Number
MTP1	Message Transfer Part Layer 1
MTP2	Message Transfer Part Layer 2
MTP3	Message Transfer Part Layer 3
NAPT	Network Address and Port Translation
NAT	Network Address Translation
NS	Network Service
PCM	Pulse Code Modulation
PCS	Personal Communication Services
PCS	Personal Communications Services
PLMN	Public Land Mobile Network
POTS	Plain Old Telephone Service
PPP	Point-to-Point Protocol
PPPoE	PPP over Ethernet protocol
PSTN	Public Switched Telephone Network
P-TMSI	Packet Temporary Mobile Subscriber Identity
QoS	Quality of Service
RA	Routing Area
RAC	Routing Area Code
RAI	Routing Area Identification
RAI	Routing Area Identity
RAN	Radio Access Network
RF	Radio Frequency
RFC	Request for Comment (IETF Standard)
RLC	Radio Link Control
RR	Radio Resource Management

APPENDIX I-continued

Table Of Acronyms	
RTCP	Real Time Control Protocol
RTCP	Real Time Control Protocol
RTP	Real Time Protocol
RTP	Real Time Protocol
SAP	Service Access Point
SCCP	Signaling Connection Control Part
SCO	Synchronous Connection-Oriented
SDCCH	Standalone Dedicated Control Channel
SGSN	Serving GPRS Support Node
SMC	Short Message Service Centre
SMS	Short Message Service
SM-SC	Short Message Service Centre
SMS-GMSC	Short Message Service Gateway MSC
SMS-IW MSC	Short Message Service Interworking MSC
SNDCP	SubNetwork Dependent Convergence Protocol
SS	Supplementary Service
SSL	Secure Sockets Layer
TCAP	Transaction Capabilities Application Part
TCP	Transmission Control Protocol
TCP	Transmission Control Protocol
TLLI	Temporary Logical Link Identity
TMSI	Temporary Mobile Subscriber Identity
TRAU	Transcoder and Rate Adaptation Unit
TTY	Text telephone or teletypewriter
UDP	User Datagram Protocol
UMA Cell	Unlicensed Mobile Access Cell (see also IAN)
UMTS	Universal Mobile Telecommunication System
UNC	UMA Network Controller (see also INC)
VLR	Visited Location Register
VMSC	Visited MSC
WLAN	Wireless Local Area Network
WSP IP	Wireless Service Provider's IP Network

1-58. (canceled)

59. A method for paging a mobile station (MS) operating in a wireless first communication system comprising a network controller for communicatively coupling the MS to a core network of a second communication system comprising a licensed radio access network, the method comprising:

establishing a Transmission Control Protocol (TCP) connection between the network controller and the MS via a wireless access point (AP);

sending a paging request message from the network controller to the MS; and

receiving, at the network controller, a paging response message from the MS, wherein each of the paging request and paging response messages comprises a plurality of information elements (IEs) that includes a protocol discriminator, a skip indicator, and a message type from which the corresponding message is to be identified, wherein the paging request message further comprises a mobile identify IE that identifies the MS.

60. The method of claim **59**, wherein the paging request message further comprises a channel needed IE identifying a channel that is needed.

61. The method of claim **59**, wherein the paging response message further comprises a ciphering key sequence number IE that specifies a ciphering key sequence number.

62. The method of claim **59**, wherein the paging response message further comprises a mobile station classmark IE that specifies the capabilities of the MS.

63. The method of claim **59**, wherein the paging response message further comprises an establishment cause IE.

64. The method of claim **59** further comprising: receiving, at the network controller, a paging request message over an A-interface from the core network, said

paging request message received prior to sending the paging request message to the MS;
identifying the MS to be paged based on a mobile identity in the paging request from the core network; and
generating the paging request message to be sent to the identified MS.

65. The method of claim **59** further comprising:
receiving, at the network controller, a paging circuit switched (CS) message over a Gb-interface from the core network, said paging CS message received prior to sending the paging request message to the MS;
identifying the MS to be paged based on a mobile identity in the paging request from the core network; and
generating the paging request message to be sent to the identified MS.

66. A network controller for communicatively coupling a mobile station (MS) operating in a wireless first communication system to a second communication system comprising a licensed radio access network and a core network, the network controller comprising:

- a first network interface comprising an Internet Protocol (IP) network interface;
- a second network interface via which messages are to be transmitted to and received from the MS via an access point (AP) communicatively coupled between the network controller and the MS, the second network interface comprising a plurality of layers implemented over the IP network interface;
- a third network interface via which the network controller connects to the core network of the second communication system; and
- circuits for generating and processing a plurality of messages transmitted over the second interface to support paging of the MS operating in the wireless first communication system, wherein the plurality of messages includes a paging request message sent from the network controller to the MS, and a paging response message received at the network controller from the MS, wherein each of the paging request and paging response messages comprises a plurality of information elements (IEs) that includes a protocol discriminator, a skip indicator, and a message type from which the corresponding message is to be identified, wherein the paging request message further comprises a mobile identify IE that identifies the MS.

67. The network controller of claim **66**, wherein the paging request message further comprises a channel needed IE identifying a channel that is needed.

68. The network controller of claim **66**, wherein the paging response message further comprises a ciphering key sequence number IE that specifies a ciphering key sequence number.

69. The network controller of claim **66**, wherein the paging response message further comprises a mobile station classmark IE that specifies the capabilities of the MS.

70. The method of claim **66**, wherein the paging response message further comprises an establishment cause IE.

71. The network controller of claim **66**, wherein the circuits are further for:
receiving, at the network controller, a paging request message over an A-interface from the core network, said paging request message received prior to sending the paging request message to the MS;
identifying the MS to be paged based on a mobile identity in the paging request from the core network; and
generating the paging request message to be sent to the MS based on the identification of the MS.

72. The network controller of claim **66**, wherein the circuits are further for:
receiving, at the network controller, a paging circuit switched (CS) message over a Gb-interface from the core network, said paging CS message received prior to sending the paging request message to the MS;
identifying the MS to be paged based on a mobile identity in the paging request from the core network; and
generating the paging request message to be sent to the MS based on the identification of the MS.

73. A non-transitory computer readable medium storing a computer program for a network controller that communicatively couples a mobile station (MS) operating in a wireless first communication system to a second communication system comprising a licensed radio access network and a core network, the computer program for execution by at least one processor to support paging of the MS, the computer program comprising sets of instructions for:

- establishing a Transmission Control Protocol (TCP) connection between the network controller and the MS via a wireless access point (AP);
- sending a paging request message from the network controller to the MS; and
- receiving, at the network controller, a paging response message from the MS, wherein each of the paging request and paging response messages comprises a plurality of information elements (IEs) that includes a protocol discriminator, a skip indicator, and a message type from which the corresponding message is to be identified, wherein the paging request message further comprises a mobile identify IE that identifies the MS.

74. The non-transitory computer readable medium of claim **73**, wherein the paging request message further comprises a channel needed IE identifying a channel that is needed.

75. The non-transitory computer readable medium of claim **73**, wherein the paging response message further comprises a ciphering key sequence number IE that specifies a ciphering key sequence number.

76. The non-transitory computer readable medium of claim **73**, wherein the paging response message further comprises a mobile station classmark IE that specifies the capabilities of the MS.

* * * * *