

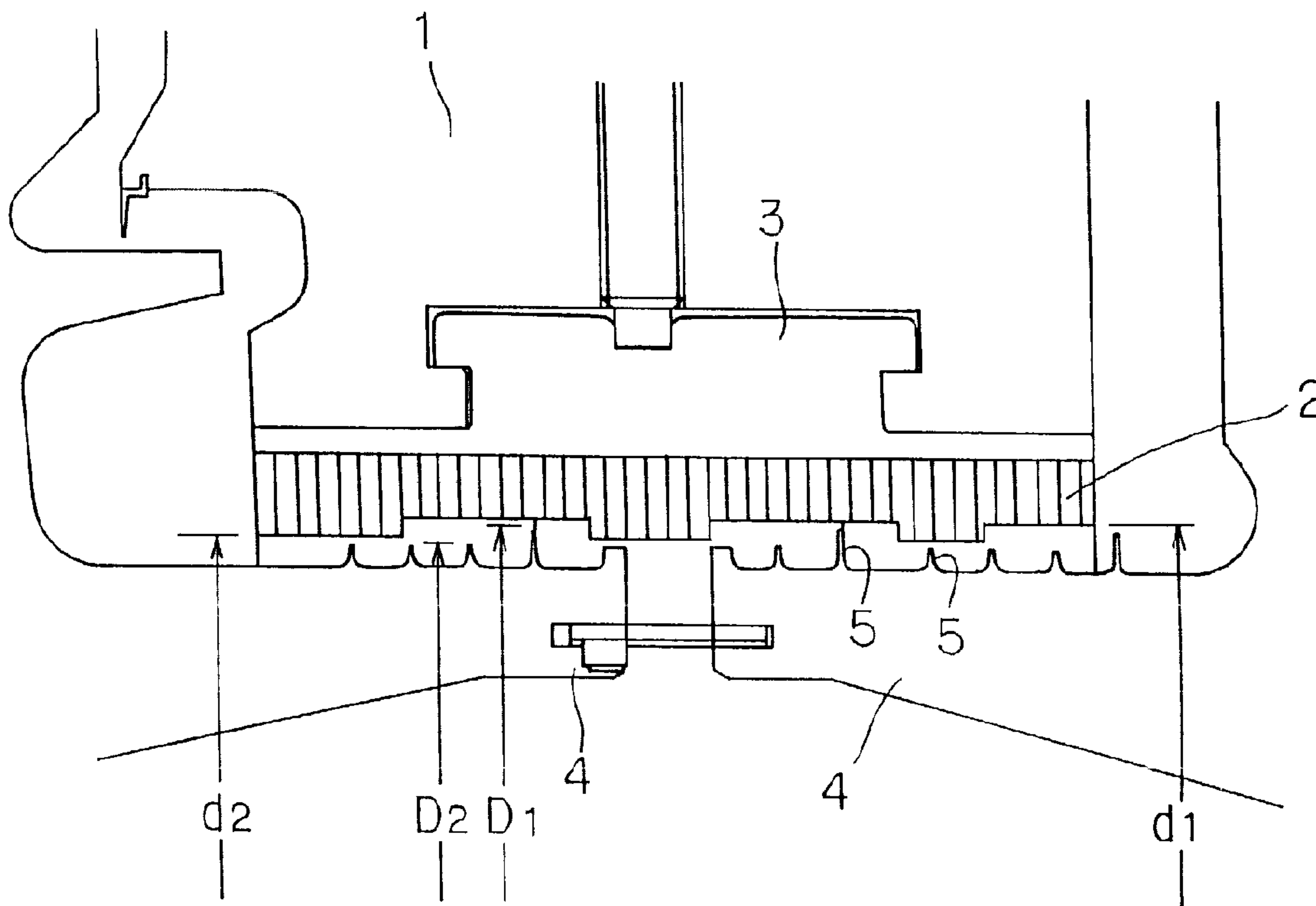

(22) Date de dépôt/Filing Date: 1998/07/27
 (41) Mise à la disp. pub./Open to Public Insp.: 1999/01/30
 (45) Date de délivrance/Issue Date: 2001/10/16
 (30) Priorité/Priority: 1997/07/30 (9-204497) JP

(51) Cl.Int.⁶/Int.Cl.⁶ F01D 11/02
 (72) Inventeurs/Inventors:
 AKAGI, Koichi, JP;
 HAGI, Naoki, JP
 (73) Propriétaire/Owner:
 MITSUBISHI HEAVY INDUSTRIES, LTD., JP
 (74) Agent: RICHES, MCKENZIE & HERBERT LLP

(54) Titre : DISPOSITIF D'ETANCHEITE DE LA PARTIE INTER-ETAGES D'UNE TURBINE A GAZ
 (54) Title: GAS TURBINE INTERSTAGE PORTION SEAL DEVICE



(57) Abrégé/Abstract:

In order to realize a seal device of gas turbine interstage portion which is excellent in a sealing ability at the time of regular operation of the gas turbine, a gas turbine interstage portion seal device is constructed by comprising a honeycomb seal (2) of ring shape provided to an inner side of a turbine stationary blade inner ring (1) and a plurality of seal fins (5) of ring shape provided to an outer side of a turbine disc seal arm portion (4). Also, an inner side surface of the honeycomb seal and outer peripheries of the plurality of seal fins, respectively, comprise large diameter ones and small diameter ones and convex and concave portions formed thereby respectively are mated with each other irregularly.

Abstract of the Disclosure

In order to realize a seal device of gas turbine interstage portion which is excellent in a sealing ability at the time of regular operation of the gas turbine, a gas turbine interstage portion seal device is constructed by comprising a honeycomb seal (2) of ring shape provided to an inner side of a turbine stationary blade inner ring (1) and a plurality of seal fins (5) of ring shape provided to an outer side of a turbine disc seal arm portion (4). Also, an inner side surface of the honeycomb seal and outer peripheries of the plurality of seal fins, respectively, comprise large diameter ones and small diameter ones and convex and concave portions formed thereby respectively are mated with each other irregularly.

GAS TURBINE INTERSTAGE PORTION SEAL DEVICE

BACKGROUND OF THE INVENTION:

Field of the Invention:

5 The present invention relates to a gas turbine interstage portion seal device.

Description of the Prior Art:

10 A gas turbine stationary blade inner side interstage portion seal in the prior art is carried out, as shown in Fig. 2, with a labyrinth seal fin 52 provided to a stationary side (that is, a stationary blade inner ring 51) and a step seal 54 provided to a rotary side (that is, a turbine disc seal arm portion 53).

15 In the gas turbine interstage portion seal system using said labyrinth seal fin 52 and step seal 54, while fluid passes through the labyrinth (throttle) portion, it flows through narrow gaps and wider gaps in turn to be pressure-lowered by the throttle effect, and generally in a rotating shaft of rotary machine, this seal system is used when the fluid
20 for sealing is a compressible gas or steam.

 It is to be noted that the labyrinth seal 52 exhibits by nature its effect while the rotary machine is in operation and its sealing ability is not necessarily good in a state out of operation.

25 In order to minimize the gas turbine interstage

portion gas leakage, stage number of the labyrinth seal fin 52 may be increased or the gap between the stationary side and the rotating shaft may be reduced. But if the stage number is increased, it leads to elongation of the rotating shaft
5 resulting in a problem in the strength of the rotating shaft and if the gap is too small, the rotating shaft will come in contact with the stationary side due to thermal expansion when there is run-out of the rotating shaft.

Therefore, the seal fin 52 is made of a soft material
10 and is worked to form a sharp edge at its end in consideration that if the contact occurs, the seal fin 52 wears quickly so that the rotating shaft may not be damaged.

The prior art gas turbine interstage portion seal, as mentioned above, is carried out with the labyrinth seal fin
15 provided on the stationary side and the step seal provided on the rotary side.

In case of this seal system, considering quickness of thermal expansion on the rotary side when the temperature of the stationary side is low at start-up time, it is necessary
20 to make the gap wider in advance for avoidance of contact of these both sides.

If the gap between said both sides is made wider, however, it will cause a lowering of sealing ability in the regular operation resulting in increase of loss of leakage and
25 this is one of the factors to lower the gas turbine performance.

SUMMARY OF THE INVENTION:

With an object to dissolve the mentioned problem, the present invention provides a gas turbine interstage portion seal device provided between a turbine stationary blade inner ring and a turbine disc seal arm portion in a gas turbine interstage portion, characterized in comprising a honeycomb seal of ring shape provided to an inner side of said turbine stationary blade inner ring and a plurality of seal fins of ring shape provided to an outer side of said turbine disc seal arm portion.

In the present invention, even if the honeycomb seal and the seal fins come in contact with each other while the gas turbine is in operation, a portion of the honeycomb seal is scraped off only and there is little influence given on the subsequent operation of the gas turbine.

Therefore, there is no need of provided a large gap between the honeycomb seal and the seal fins in consideration of quickness of thermal expansion on the rotary side at the time of start-up of gas turbine and an excellent sealing ability becomes possible to be maintained through the regular operation.

In the gas turbine interstage portion seal device as mentioned above, it is preferable that an inner side surface of said honeycomb seal comprises large diameter surfaces and small diameter surfaces, outer peripheries of said plurality

of seal fins comprise large diameter peripheries and small diameter peripheries and convex and concave portions on the inner side surface of said honeycomb seal and convex and concave portions of the outer peripheries of said plurality of seal fins are mated with each other irregularly, then the influence given on the seal effect by the contact of the honeycomb seal and the seal fins can be reduced.

In the present invention, because the contact of the inner side surface of the honeycomb seal and the outer peripheries of the seal fins is done portionally only, is frictional resistance is small and generation of the frictional heat can be suppressed.

BRIEF DESCRIPTION OF THE DRAWINGS:

Fig. 1 is an explanatory view of a gas turbine interstage portion seal device of one embodiment according to the present invention, wherein Fig. 1(a) is a cross sectional side view and Fig. 1(b) is a partially enlarged perspective view.

Fig. 2 is an explanatory view of a prior art gas turbine interstage portion seal device.

DESCRIPTION OF THE PREFERRED EMBODIMENTS:

A gas turbine interstage portion seal device of one embodiment according to the present invention will be described

with reference to Fig. 1.

In the seal device of the embodiment shown in Fig. 1, there are provided a honeycomb ring 3 fitted to an inner side of a gas turbine stationary blade inner ring 1, a honeycomb seal 2 of honeycomb shape fitted to an inner side of the honeycomb ring 3 and a plurality of seal fins 5 formed integrally with a turbine disc seal arm portion 4 so as to be fitted to an outer side of the turbine disc seal arm portion 4.

An inner side surface of the honeycomb seal 2 comprises large diameter surfaces and small diameter surfaces which locate at distances d_1 and d_2 , respectively, from a gas turbine rotational axis center so that convex and concave portions are formed on the inner side surface of the honeycomb seal 2. Also, outer peripheries of the plurality of seal fins 5 formed integrally with the turbine disc seal arm portion 4 comprise large diameter peripheries and small diameter peripheries which locate at distances D_1 and D_2 , respectively, from the gas turbine rotational axis center so that convex and concave portions are formed on the outer peripheries of the plurality of seal fins 5. And the convex and concave portions of the honeycomb seal 2 and the convex and concave portions of the seal fins 5 are mated with each other irregularly.

In the above, even if the honeycomb seal 2 provided to the stationary side and the seal fins 5 provided to the rotary side come in contact with each other while the gas turbine is

in operation, a portion of the honeycomb seal 2 which has contacted the seal fins 5 is scraped off only and there is little influence given on the subsequent operation of the gas turbine.

Thus, there is no need of providing a large gap
5 between the honeycomb seal 2 and the seal fins 5 in consideration of quickness of thermal expansion on the rotary side at the time of start-up of the gas turbine and an excellent sealing ability has become possible to be maintained through the regular operation.

10 Further, the inner side surface of the honeycomb seal 2 comprises the large diameter surfaces and small diameter surfaces so as to form the concave and convex portions thereon, the outer peripheries of the plurality of seal fins 5 also
15 comprise the large diameter peripheries and small diameter peripheries so as to form the convex and concave portions thereof and said convex and concave portions of the honeycomb seal 2 and the seal fins 5 are mated with each other irregularly, thereby even if the honeycomb seal 2 makes contact with the seal
20 fins 5, there occur no entire contact but partial contacts only and there is less frictional resistance, which results in suppression of generation of frictional heat. Further, because the fluid throttle portion is formed by the honeycomb seal 2 and the seal fins 5, the effect of throttle can be maintained
enough.

25 According to the gas turbine interstage portion seal

device of the present invention, there are provided the
honeycomb seal of ring shape to the inner side of the turbine
stationary blade inner ring and the plurality of seal fins of
ring shape to the outer side of the turbine disc seal arm portion,
5 thereby even if the honeycomb seal and the seal fins come in
contact with each other while the gas turbine is in operation,
a portion of the honeycomb seal is scraped off only and there
is little influence given on the subsequent operation of the
gas turbine, thus the gap between the honeycomb seal and the
10 seal fins can be made narrower so that an excellent sealing
ability becomes possible to be maintained through the regular
operation of the gas turbine and enhancement of the gas turbine
performance becomes possible.

Also, according to the gas turbine interstage portion
15 seal device constructed such that the inner side surface of the
honeycomb seal and the outer peripheries of the plurality of
seal fins, respectively, comprise large diameter ones and small
diameter ones, and convex and concave portions formed thereby
respectively are mated with each other irregularly, the contact
20 of the inner side surface of the honeycomb seal and the outer
peripheries of the seal fins is done portionally only, hence
generation of frictional heat can be suppressed.

It is understood that the invention is not limited
to the particular construction and arrangement herein
25 illustrated and described but embraces such modified forms

thereof as come within the scope of the following claims.

WHAT IS CLAIMED IS:

1. A gas turbine interstage portion seal device provided between a turbine stationary blade inner ring and a turbine disc seal arm portion in a gas turbine interstage portion, comprising a honeycomb seal of ring shape provided to an inner side of said turbine stationary blade inner ring and a plurality of seal fins of ring shape provided to an outer side of said turbine disc seal arm portion, characterized in that an inner side surface of said honeycomb seal comprises large diameter surfaces and small diameter surfaces, outer peripheries of said plurality of seal fins comprise large diameter peripheries and small diameter peripheries and convex and concave portions on the inner side surface of said honeycomb seal and convex and concave portions of the outer peripheries of said plurality of seal fins are mated with each other irregularly.
2. The gas turbine interstage portion of claim 1, wherein at least one of said large diameter surfaces of said honeycomb seal is positioned opposite to both large diameter peripheries and small diameter peripheries of said plurality of seal fins.

3. The gas turbine interstage portion of claim 1,
wherein said large diameter surfaces of said honeycomb
seal are positioned opposite to both large diameter
peripheries and small diameter peripheries of said
5 plurality of seal fins.

4. The gas turbine interstage portion of claim 1,
wherein the radial distance between said outer peripheries
of said plurality of seal fins and said inner side surface
10 of said honeycomb seal varies.

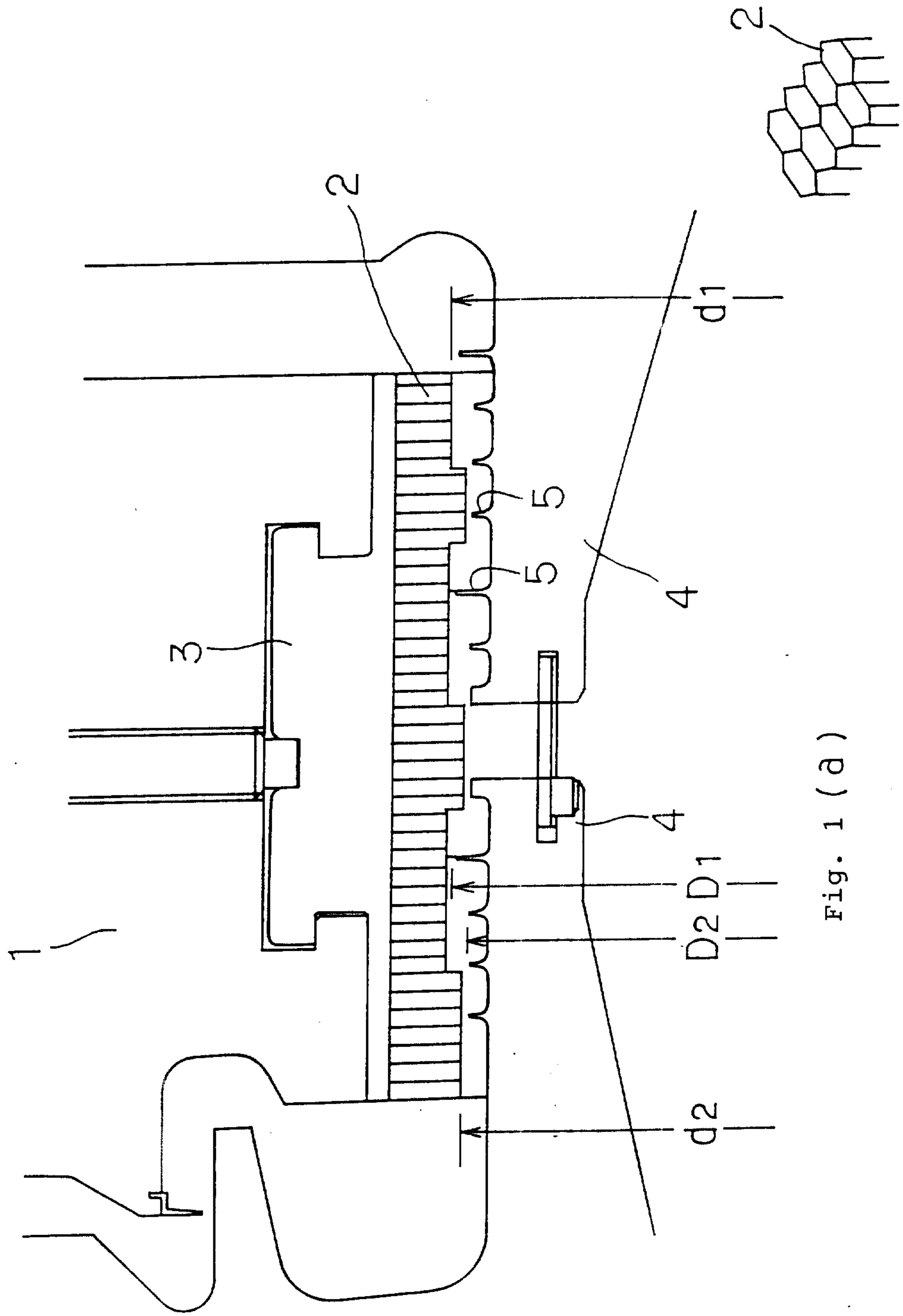

Fig. 1 (a)

Fig. 1 (b)

Fig. 2

