

Aug. 8, 1961

E. H. SIMONSEN
TRAY SUPPORT BRACKET

2,995,409

Filed June 13, 1958

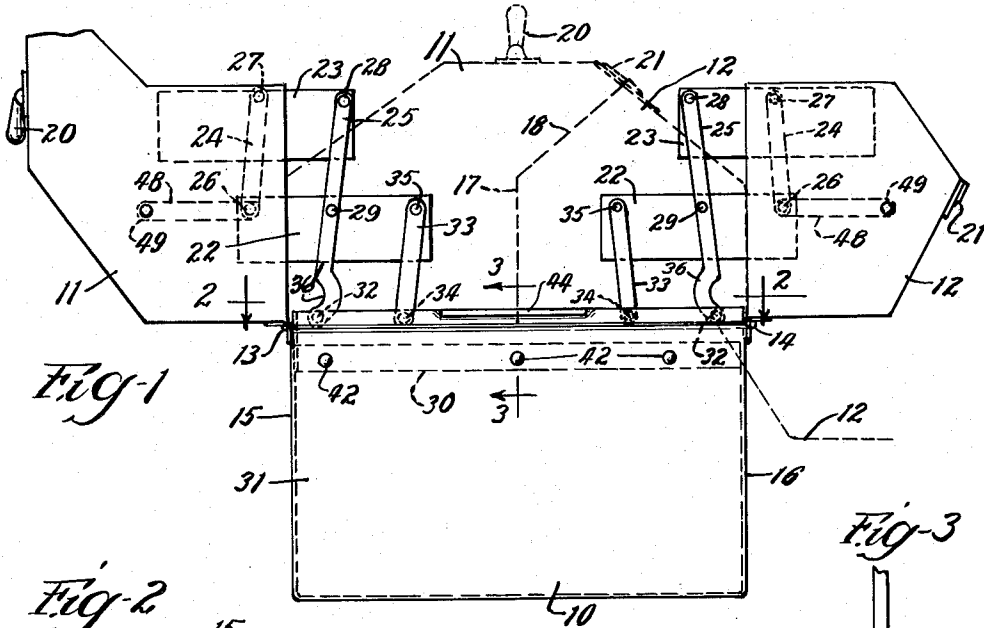

Fig. 2

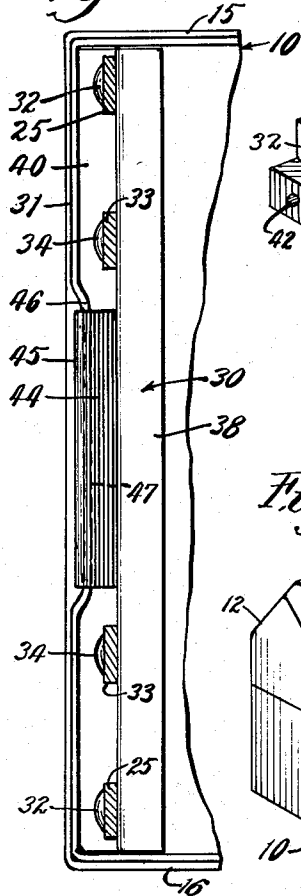

Fig. 3

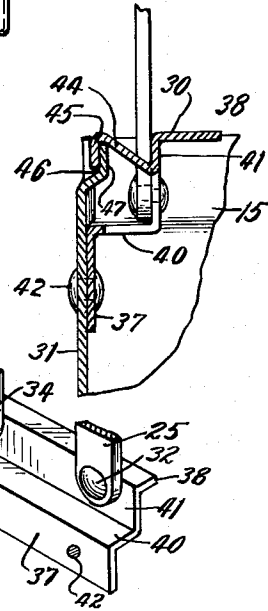

Fig. 4

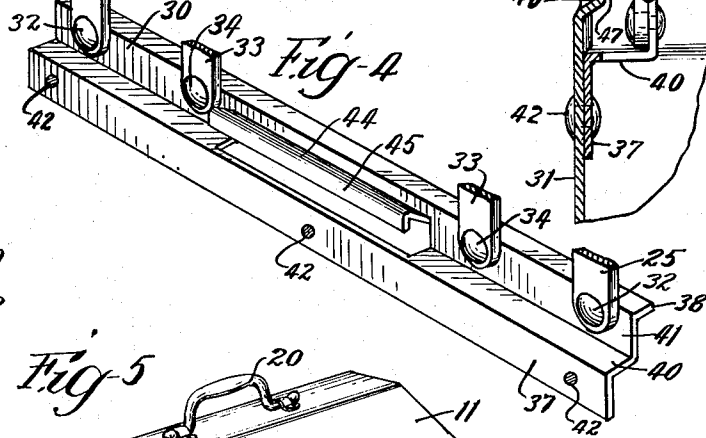
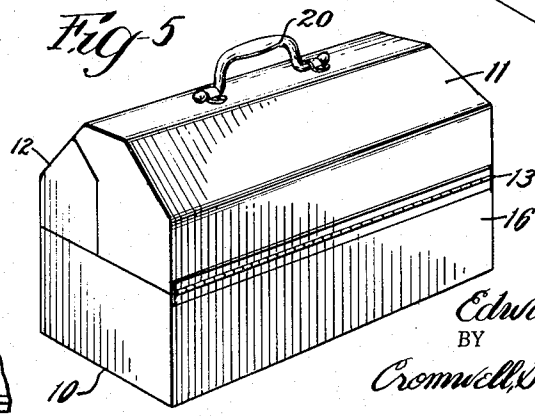

Fig. 5



INVENTOR.
Edward H. Simonsen
BY
Cromwell, Strait & Warden
Attys.

1

2,995,409

TRAY SUPPORT BRACKET

Edward H. Simonsen, Elmwood Park, Ill., assignor to
Simonsen Metal Products Company, Chicago, Ill., a
corporation of Illinois

Filed June 13, 1958, Ser. No. 741,924

6 Claims. (Cl. 312—325)

This invention relates to hardware or fixtures for supporting a compartment forming tray in an article storing or carrying container such as a tool box, tackle box, trunk or the like, and is more particularly concerned with improvements in an end bracket which is adapted to be attached to the upper margin of the end wall of the bottom of the container so as to support in horizontally disposed relation therein one or more of the tray members.

It is a general object of the invention to provide an improved end bracket for supporting in an open top outer container one or more inner tray members which are connected to the bracket by a pair of parallel links enabling the tray to be swung from a closed position within the top of the container to an open position where it is elevated and laterally displaced above the container.

It is a more specific object of the invention to provide an elongate bracket of angular cross section which is constructed for supporting the end of a tray member in the top of a receptacle whereby the tray member may be attached to the bracket by a pair of parallel links which enable the tray member to be swung upwardly and outwardly of the bracket, the bracket being provided with angularly related top and bottom flanges arranged so that the bottom flange is adapted to be attached to the inner side wall of the container and the bracket being provided with an upwardly and outwardly extending brace member arranged so that it extends from the top flange to the top edge of the container end wall and serves to brace the top flange against movement in the direction inwardly and downwardly of the container.

It is a more specific object of the invention to provide an elongate end bracket for supporting in an open or closed tray-like container one or more tray members which are mounted thereon by means of a pair of parallel links and wherein the bracket comprises an outer vertical and an inner horizontal flange which are integrally connected to each other by horizontal and vertical webs and wherein a bracing tongue is struck from the webs and bent upwardly and outwardly to provide a hook shaped marginal portion which is engaged over the top edge of the end wall of the container when the vertical flange of the bracket is fastened to the inner face of the end wall at a predetermined point below the top edge thereof, which tongue serves to brace the bracket against shearing, bending and twisting movement.

These and other objects and advantages of the invention will be apparent from a consideration of the tool box and tray structure which is shown by way of illustration in the accompanying drawings wherein:

FIGURE 1 is an end elevation of a mechanic's tool box or fishing tackle box having sectional top closure members and a plurality of trays pivotally mounted therein by means of parallel linkages attached at each end of the box to a supporting bracket which incorporates therein the principal features of the invention;

FIGURE 2 is a fragmentary section taken on a horizontal plane indicated by the line 2—2 of FIGURE 1, to an enlarged scale;

FIGURE 3 is a fragmentary section taken on the line 3—3 of FIGURE 1 to a still larger scale;

2

FIGURE 4 is a perspective view of the link supporting end bracket; and

FIGURE 5 is a perspective view of the tool box in completely closed position.

Referring to the drawings, there is illustrated in FIGURES 1 and 5 a mechanic's tool box or chest, of the portable type, which comprises a bottom forming portion or section 10, in the form of an open top tray-like rectangular container and cooperating cover or closure members 11 and 12 hinged at 13 and 14 to the top edges of the oppositely disposed side walls 15 and 16 of the bottom member, the hinges 13 and 14 being on parallel axes. The two cover members 11 and 12 are constructed so that the meeting edges of their end walls are on a line having a vertical portion 17 extending upwardly on the vertical center line and a diagonal portion 18 extending toward one of the side walls and the one cover member 11 is provided with a top horizontal wall on which there is secured a carrying handle 20. The box cover members 11 and 12 may be provided with suitable latches indicated at 21.

Two identical pairs of trays 22 and 23 are mounted for swinging movement within the box. The trays 22 and 23 may be of identical construction, each being generally rectangular in longitudinal and transverse section, of relatively shallow depth, and of a width which is slightly less than half the width of the interior of the box so that in the closed position of the box the trays may be nested completely within the cover members 11 and 12.

The trays 22 and 23 of each pair are connected at corresponding ends by a pair of parallel links 24 and 25. The outer link 24 is pivoted at opposite ends to the end walls of the trays 22 and 23, the lower pivot 26 being located adjacent the upper outer corner of the bottom tray 22, as viewed in FIGURE 1, and the upper pivot 27 being located adjacent the upper edge and approximately in the middle of the end wall of the tray 23. The inner link 25 is pivoted at its upper end at 28 to the end wall of the upper tray 23 adjacent the upper inner corner thereof and to the lower tray on the pivot 29 located adjacent the upper edge at the middle of the end wall of the lower tray 22. The inner link 25 is extended downwardly below the lower tray 22 and pivoted to an end supporting bracket 30 which is secured to the end wall 31 of the bottom portion 10 of the box and which is of special construction. The link 25 is connected to the end support bracket 30 by the pivot 32. A third link 33, which is arranged parallel to the links 24 and 25, is pivoted at its lower end to the bracket 30 by the pivot 34 and has its upper end pivoted to the upper corner of the end wall of the lower tray 22 by the pivot 35. The link 25 is provided with a curved portion 36 near the bottom pivot 32 in which the top edge of the side wall 15 engages when the cover member 11 is swung to the fully open position, the latter being indicated by the dotted lines in FIGURE 1.

The bracket 30, as shown in FIGURES 2, 3 and 4, may be formed from an elongate metal strip bent into angular cross section, providing a vertical flange 37 along the lower edge and a top horizontal flange 38 along the upper edge. The flanges 37 and 38 are at right angles to each other and are integrally connected by horizontally and vertically disposed angularly related web sections 40 and 41. The bracket 30 is adapted to be positioned within the box 10 so that the vertical flange 38 may be secured to the inside of the end wall 31 adjacent the top margin thereof by rivets 42 or other equivalent fastening means. The top flange 38 is arranged in a horizontal plane for

supporting the weight of the trays 22 and 23 in the closed position of the latter, the links 25 and 33 being pivoted to the vertical flange 41 of the bracket on the pivots 32 and 34, respectively.

The support bracket 30 is provided with a bracing tongue 44 which is preferably formed by punching or cutting the material from the web portions 40 and 41 of the bracket or by welding a piece of metal thereon. The tongue is bent upwardly and outwardly so that it is inclined to the vertical web 41 and its free end is bent into a hook formation 45 which is adapted to engage over the top edge 46 of an inwardly offset portion 47 of the end wall 31 of the box bottom 10 when the bracket 30 is secured in proper position on the end wall. The tongue 44 extends at an angle upwardly and outwardly relative to the vertical web 41 from a point spaced somewhat below the upper edge of the web 41 (FIGURE 3) so that it braces the bracket 30 against movement inwardly of the box and holds the parallel links in vertical alignment. The bracing tongue 44 also prevents shearing of rivets 42 when the trays are loaded with weight since strain on the rivets is relieved and the weight of the trays is suspended on the ledge 47 through the bracket and the bracing tongue 44.

An operating link 48 is preferably connected between each pair of trays 22 and 23 and an end wall of the adjoining cover member, which link 48 is connected at one end to the pivot shaft 26 and at the other end to a pivot 49 on the cover member so that the trays will open and close with corresponding movements of the cover members.

While specific materials and particular details of construction are referred to in describing the form of the invention which is illustrated in the drawings, it will be understood that other materials and different details of construction may be resorted to within the spirit of the invention.

I claim:

1. In a container comprising an open top member of rectangular form and one or more rectangular trays supported in the top thereof on parallel links at opposite ends thereof, a tray supporting bracket adapted for attachment to the inner side of the end wall of the container member, said bracket having a flange which is attached in face-to-face relation on the end wall of the container member adjacent the top marginal edge thereof and a second flange disposed at right angles to the first flange which extends inwardly of the end wall of the container to a position underlying the end of a tray, said flanges being connected by intervening web portions and a bracing tongue struck from said web portions and bent into the form of an outwardly and upwardly extending brace having a hook-shape cross section with the free edge engaging in interlocking relation with the top marginal edge of the container end wall on which the first mentioned flange is attached.

2. In a container having an open top body member of rectangular form and one or more rectangular trays supported therein on links which are pivoted thereto at opposite ends thereof, an elongate tray supporting bracket member adapted for attachment to the inner face of the end wall of the container body member, said bracket member having a vertical flange which is adapted to be attached to the end wall of the container body member below the top marginal edge thereof and a horizontal flange which is disposed in a plane extending inwardly of the end wall of the container for supporting the end of a tray, said vertical and horizontal flanges being connected by intervening horizontal and vertical web portions and a bracing tongue struck from said web portions and bent into the form of a hook extending outwardly and upwardly of the vertical web portion with a reversely bent outer edge portion engaging over the top marginal edge of the container end wall on which the bracket is attached.

3. Means for supporting one or more rectangular trays

in the top of a rectangular compartment forming member on parallel links pivotally connected to opposite ends thereof, comprising a supporting bracket member adapted for attachment to the inner face of an end wall of the compartment forming member, said bracket member having a bottom flange which is adapted to be secured to said end wall adjacent the top marginal edge thereof and a top flange which extends inwardly of said end wall for engaging beneath the end of a tray, said flanges being spaced from each other by connecting web portions and a bracing member extending outwardly and upwardly from said web portions, said bracing member being in the form of an outwardly and upwardly extending hook formation and having the free edge thereof engaging with the top marginal edge of the end wall of said compartment forming member.

4. In a container having a bottom section of rectangular form and one or more rectangular trays supported therein on parallel links pivoted at opposite ends of said trays, an elongate tray supporting bracket member attached to the end wall of the container bottom section, said bracket member having a vertical flange portion which is attached to the end wall of the container bottom member adjacent the top marginal edge thereof and a horizontal flange portion which is spaced inwardly of the end wall of the container bottom section so as to extend beneath the end of a tray, said flanges being connected by angularly related web portions and having a tongue bent into the form of an outwardly and upwardly extending hook which is positioned to engage over the top marginal edge of the container end wall to which the bracket member is attached.

5. A bracket for supporting one or more rectangular trays in the top of a rectangular compartment forming member with the trays being connected to the bracket by parallel links, said bracket being constructed so that it may be mounted on the inside of an end wall of the compartment forming member with the lower ends of the parallel links pivotally connected thereto and in position to engage in supporting relation the bottom of the tray in the lowered position of the latter, said bracket having a vertically disposed bottom flange for attachment to the inner face of the end wall of the compartment forming member below the upper edge thereof, said bracket having a top horizontally disposed flange which is adapted to extend inwardly of said end wall in position for engaging in supporting relation beneath the end of the tray, said flanges being vertically spaced from each other by connecting angularly related web portions, and a bracing member in the form of a tongue extending from the innermost one of said web portions outwardly and upwardly of said web portions, said bracing member having a hook formation at its free upper edge for engaging over the upper edge of the end wall of said compartment forming member to which said bracket is attached.

6. A bracket for supporting one or more rectangular trays in the top of a rectangular compartment forming member with the trays being connected to the bracket by parallel links, said bracket being constructed so that it may be positioned in the compartment forming member to engage in supporting relation the bottom of the tray in the lowered position of the latter and to have the lower ends of the parallel links connected thereto, said bracket having a vertically disposed lower flange adapted for attachment to the inner face of the vertical end wall of the compartment forming member, said bracket having an upper horizontally disposed flange which is adapted to extend inwardly of said end wall a sufficient distance for engaging in supporting relation beneath the end of the tray, said flanges being spaced from each other by connecting horizontally and vertically disposed web portions and a bracing member in the form of an integral tongue which is cut from the connecting web portions and bent into an upwardly and outwardly extending hook formation with a reversely bent upper edge which is adapted to

5

engage over the upper outer edge of the end wall of said compartment forming member to which said bracket is attached thereby to form a diagonally upwardly extending bracing strut between said bracket web portions and a portion of said end wall which is spaced above the lower flange of said bracket.

5

6**References Cited in the file of this patent****UNITED STATES PATENTS**

1,893,526	Shriver -----	Jan. 10, 1933
2,361,079	Berry -----	Oct. 24, 1944
2,365,252	Daum -----	Dec. 19, 1944
2,675,290	Berry -----	Apr. 13, 1954