



(51) International Patent Classification:

B24B 3/54 (2006.01) *B24B 3/36* (2006.01)
B23Q 3/06 (2006.01) *B24B 41/06* (2012.01)

(21) International Application Number:

PCT/SE2016/050476

(22) International Filing Date:

23 May 2016 (23.05.2016)

(25) Filing Language:

English

(26) Publication Language:

English

(30) Priority Data:

1550702-3 1 June 2015 (01.06.2015) SE

(71) Applicant: **TORMEK AB** [SE/SE]; Torphyttvägen 40,
SE-711 34 Lindesberg (SE).

(72) Inventor: **PERSSON, Håkan**; Örebrovägen 9, SE-711 31
Lindesberg (SE).

(74) Agent: **STRÖM & GULLIKSSON AB**; P.O. Box 5275,
SE-102 46 Stockholm (SE).

(81) Designated States (unless otherwise indicated, for every
kind of national protection available): AE, AG, AL, AM,

AO, AT, AU, AZ, BA, BB, BG, BH, BN, BR, BW, BY,
BZ, CA, CH, CL, CN, CO, CR, CU, CZ, DE, DK, DM,
DO, DZ, EC, EE, EG, ES, FI, GB, GD, GE, GH, GM, GT,
HN, HR, HU, ID, IL, IN, IR, IS, JP, KE, KG, KN, KP, KR,
KZ, LA, LC, LK, LR, LS, LU, LY, MA, MD, ME, MG,
MK, MN, MW, MX, MY, MZ, NA, NG, NI, NO, NZ, OM,
PA, PE, PG, PH, PL, PT, QA, RO, RS, RU, RW, SA, SC,
SD, SE, SG, SK, SL, SM, ST, SV, SY, TH, TJ, TM, TN,
TR, TT, TZ, UA, UG, US, UZ, VC, VN, ZA, ZM, ZW.

(84) Designated States (unless otherwise indicated, for every
kind of regional protection available): ARIPO (BW, GH,
GM, KE, LR, LS, MW, MZ, NA, RW, SD, SL, ST, SZ,
TZ, UG, ZM, ZW), Eurasian (AM, AZ, BY, KG, KZ, RU,
TJ, TM), European (AL, AT, BE, BG, CH, CY, CZ, DE,
DK, EE, ES, FI, FR, GB, GR, HR, HU, IE, IS, IT, LT, LU,
LV, MC, MK, MT, NL, NO, PL, PT, RO, RS, SE, SI, SK,
SM, TR), OAPI (BF, BJ, CF, CG, CI, CM, GA, GN, GQ,
GW, KM, ML, MR, NE, SN, TD, TG).

Published:

— with international search report (Art. 21(3))

(54) Title: A JIG DEVICE FOR A GRINDING MACHINE AND A GRINDING MACHINE COMPRISING THE JIG DEVICE

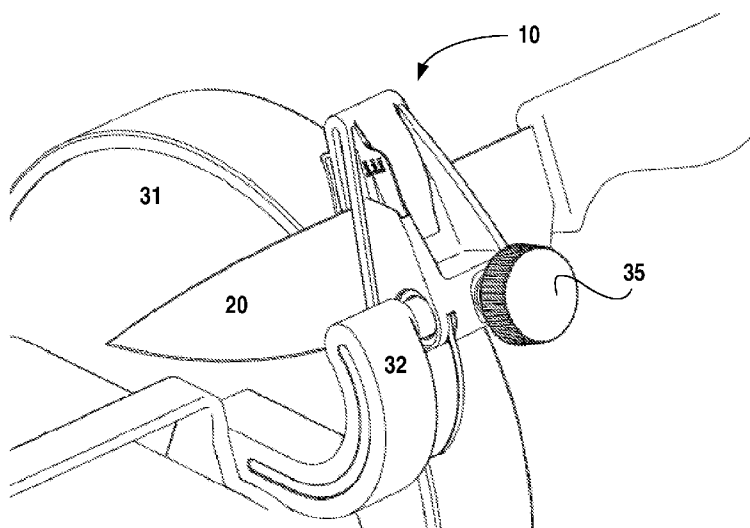

Figure 5

(57) Abstract: A grinding machine (30) has a rotatable grindstone (31) and a support structure (32). A jig device (10) is provided for bringing a knife blade (20) to be sharpened into controlled engagement with the grindstone (31). A jig arm (11) of the jig device (10) is provided with attachment means (13) for attachment to the support structure (32) in a proper position for the grinding of the knife blade (20). The jig device (10) also comprises a resilient clamp (12) for receiving and fixing the knife blade (20) in the clamp (12), in operation.



**A JIG DEVICE FOR A GRINDING MACHINE AND A GRINDING MACHINE
COMPRISING THE JIG DEVICE**

Priority

5 This application claims the benefit of priority to Swedish patent application number 1550702-3, filed on June 1, 2015.

 The disclosure the above-referenced patent application is hereby expressly incorporated by reference in its entirety.

10 **Technical Field**

 The present disclosure generally relates to a jig device for bringing a knife blade to be sharpened into controlled engagement with a grindstone of a grinding machine. The present disclosure also relates to a grinding machine comprising a rotatable grindstone and a support structure, wherein said jig device is removably or
15 irremovably attached to the support structure such that the jig device can be placed tangentially to and closely over, or at, the grindstone.

Background

 There are many known examples of jig devices, or jig means, intended for
20 knife grinding in a grinding machine. In many cases the obtained result with regard to the evenness of the sharpening and the edge angle may be dependent on the skill of the user. In other cases where the skill needed by the user for obtaining a good grinding result is less demanding, the knife may have to be attached, or fixed, in the jig device in a relatively complicated manner.

25 The European patent application EP 2 883 655 A1 discloses jig means for a grinding machine and a grinding machine comprising the jig means. EP 2 883 655 A1 was filed before, but published after, June 1, 2015. The corresponding United States patent application US 2015/0165582 A1 was also filed before, but published after, June 1, 2015.

30

Summary

It is in view of the above considerations and others that the various embodiments of the present invention have been made.

A general object is to provide an improved jig device for bringing a knife blade
5 to be sharpened into controlled engagement with a grindstone of a grinding machine.

According to a first aspect, there is provided a jig device for bringing a knife blade to be sharpened into controlled engagement with a grindstone of a grinding machine.

Advantageously, the grinding machine is of a type comprising a rotatable
10 grindstone and a support structure, wherein said jig device is removably attachable to said support structure such that the jig device can be placed tangentially to and closely over, or at, the grindstone.

The jig device comprises a clamp for holding a knife blade. In other words, the clamp may be configured to hold a knife blade. The clamp comprises a first and a
15 second branch, which are joined by a bend. Furthermore, the first branch comprises a backside and a distal end adapted to support an edge of the knife blade in a grinding operation. The jig device also comprises a jig arm having an abutment surface for the clamp and attachment means for attaching the jig arm to a support structure of a grinding machine. Furthermore, the clamp is made of pliable material (e.g., a resilient
20 material such as a polymer material having resilient properties) and the jig arm is made of rigid material (e.g., a metal) such that the knife blade is held firmly and resiliently in the jig device. Still further, the backside of the clamp is attached to the abutment surface of the jig arm and is further oriented, or positioned, relative to the attachment means of the jig arm such that the distal end of the first branch of the clamp faces the grindstone
25 of a grinding machine in operation.

In one embodiment, essentially the entire length of the backside of the first branch abuts against the abutment surface of the jig arm.

In one embodiment, the backside of the first branch is oriented, or placed, relative to the jig arm such that the distal end of the first branch is adapted to be placed
30 tangentially to the grindstone and to face towards a direction that is essentially opposite to a direction of rotation of the grindstone during operation.

In an advantageous embodiment, the attachment means comprise a hole for engagement with a support bar, e.g. a generally cylindrical rod, of the support structure. In some embodiments, the attachment means may further comprise a threaded pin with a knob positioned at the hole. The threaded pin with the knob may be used for fastening the jig device to the support bar of the support structure. In some embodiments, the attachment means may additionally comprise a protruding member for engagement with a support member of the support structure and for positioning the jig device relative to the grindstone.

In some embodiments, the protruding member may have a bent shape which is adapted to engage with a corresponding bent shape of the support member in a male-female connection manner. The bent shape may be arch-shaped. In some embodiments, the protruding member is made of rigid material, such as a rigid polymer material. In advantageous embodiments, the jig arm is further provided with a scale with desired angles for the grinding of the knife blade to be sharpened. The protruding member may be used to assist in adjusting the desired angle when the protruding member is positioned in locked engagement (i.e., lockably engaged) with the support member of the support structure.

In some embodiments, the earlier-mentioned pliable material is a resilient material. The resilient material may, for example, be a polymer material having resilient properties.

In some embodiments, the earlier-mentioned rigid material may be a metal.

Preferably, but not necessarily, the clamp may comprise a waste material collecting means (or, waste collecting device) adapted to collect waste material from the knife blade during operation. The waste material collecting means may advantageously be positioned at the second branch of the clamp. For example, the waste collecting means may be positioned to face the rotatable grindstone in operation. In some embodiments, the waste collecting means comprises a magnetic element adapted to collect waste material from the knife blade by means of magnetic attraction arising between the magnetic element and any waste material resulting from a knife blade being sharpened during operation.

Another general object is to provide an improved grinding machine with a jig device for bringing a knife blade to be sharpened into controlled engagement with a rotatable grindstone of the grinding machine.

According to a second aspect, there is provided a grinding machine comprising
5 a rotatable grindstone and a support structure. The jig device according to the first aspect is removably attached (or, alternatively, irremovably attached) to the support structure such that the jig device can be placed tangentially to and closely over, or at, the grindstone. Furthermore, the support structure comprises a support member fixed to the grinding machine and extending in a direction which is substantially perpendicular
10 to a rotational axis of the grindstone. The support structure also comprises a support bar (e.g., a generally cylindrical rod) attached to the support member and extending in a direction which is substantially parallel with the rotational axis of the grindstone.

In other words, there is provided a grinding machine comprising a rotatable grindstone and a support structure, wherein the support structure comprises a support
15 member fixed to the grinding machine and extending in a direction which is substantially perpendicular to a rotational axis of the grindstone, and a support bar (e.g., a generally cylindrical rod) attached to the support member and extending in a direction which is substantially parallel with the rotational axis of the grindstone. A jig device for bringing a knife blade to be sharpened into controlled engagement with the rotatable
20 grindstone is removably or irremovably attached to the support structure of the grinding machine. Furthermore, the jig device comprises a clamp for holding a knife blade. The clamp comprises a first and a second branch joined by a bend. Furthermore, the first branch comprises a backside and a distal end adapted to support an edge of the knife blade in a grinding operation. The jig device also comprises a jig arm having an
25 abutment surface for the clamp and attachment means for attaching the jig arm to a support structure of a grinding machine. Furthermore, the clamp is made of pliable material (e.g., a resilient material) and the jig arm is made of rigid material (e.g., a metal) such that the knife blade is held firmly and resiliently in the jig device. Still further, the backside of the clamp is attached to the abutment surface of the jig arm and
30 is further oriented, or positioned, with respect to the attachment means of the jig arm

such that the distal end of the first branch of the clamp faces the grindstone of a grinding machine in operation.

In advantageous embodiments, the support member has a bent shape. The bent shape may be arch-shaped. An arch-shaped support member may include an arch
5 extending upwardly relative to the surface where the support member is fixed to the grinding machine. The support member having the bent shape may further be adapted to receive the protruding member of the jig arm such that the jig arm can be releasably locked to the support member in a male-female connection manner and positioned relative to the grindstone.

10

Brief Description of the Drawings

The various embodiments of the invention will be described in further detail below under reference to the accompanying drawings, in which:

Figure 1 is an isometric view of a grinding machine comprising a jig device, in
15 accordance with an embodiment;

Figure 2 is an exploded view of the grinding machine shown in Fig. 1;

Figure 3 is a side view of a jig device attached to a support structure of the grinding machine;

Figures 4-5 schematically illustrate the jig device when a knife blade is
20 resiliently fixed by a clamp of the jig device;

Figure 6 is a side view illustrating the jig device in operation; and

Figures 7A-7E schematically show an embodiment of a jig device from different angles.

25

Detailed Description

The present invention will now be described more fully hereinafter. The invention may, however, be embodied in many different forms and should not be construed as limited to the embodiments set forth herein; rather, these embodiments are provided by way of example so that this disclosure will be thorough and complete, and
30 will fully convey the scope of the invention to those persons skilled in the art. Like reference numbers refer to like elements throughout the description.

As will be further detailed herein, this disclosure proposes a jig device 10, or grinding jig, for knives. More particularly, this disclosure proposes a jig device 10 for bringing a knife blade to be sharpened into controlled engagement with a grindstone 31 of a grinding machine 30. The present disclosure also proposes a grinding machine 30 having a rotatable grindstone 31 and a support structure 32 for supporting the jig device 10 in operation. The above-mentioned jig device, or grinding jig, may be removably or irremovably attached to the support structure of the grinding machine such that the jig device can be placed, or positioned, tangentially to and closely over (or at) the rotatable grindstone of the grinding machine.

With reference to figures 1-6, an example embodiment of a jig device 10 for bringing a knife blade 20 to be sharpened into controlled engagement with a grindstone 31 of a grinding machine 30 will be described. Figure 1 is a side view of the grinding machine 30, or grinding apparatus, in accordance with an example embodiment. Various embodiments of the jig device 10, or grinding jig, can advantageously be used together with the grinding machine 30 of the type illustrated in figure 1. Figure 2 is an exploded view of the grinding machine 30 shown in figure 1. Figure 3 is a side view of a jig device attached to a support structure of the grinding machine 30 of figures 1 and 2. Furthermore, figures 4 and 5 schematically illustrate the jig device 10 when a knife blade 20 is resiliently fixed by a clamp 12 of the jig device 10.

As can be seen in figures 1-5, the grinding machine 30 comprises a rotatable grindstone 31. The grindstone 31 is rotatable around its rotational axis R, e.g. by means of a motor. In other words, a motor may be provided to drive the rotation of the grindstone 31. For example, the motor may be an electric motor (not shown) placed inside the grinding machine 10.

Furthermore, the grinding machine 30 is provided with a support structure 32. Advantageously, but not necessarily, the support structure 32 comprises a support member 32A fixed to the grinding machine 30, e.g. at a top surface 33 of the grinding machine 30. The support member extends in a direction D1 which is substantially perpendicular to a rotational axis R of the rotatable grindstone 31. A support bar 32B is attached to the support member 32A and further extends in a direction D2 which is

parallel, or substantially parallel, to the rotational axis R of the grindstone 31. In this embodiment, the support bar 32B is exemplified by an essentially cylindrical rod.

Preferably, but not necessarily, the support member 32A may have a bent shape. The bent shape may be arch-shaped, as is schematically illustrated in Fig. 1. An arch-shaped support member 32A may hence include an arch 32A', which extends upwardly relative to the surface 33 where the support member 32A is fixed to the grinding machine 30. As is illustrated in Fig. 1, the support bar 32B may be attached to the support member 32A at the distal end of the arch-shaped support member 32A.

Figure 6 is a side view of the jig device 10 illustrated in figures 1-5. As will be appreciated, this jig device 10 is suitable for bringing a knife blade 20 to be sharpened into controlled engagement with the grindstone 31 of the grinding machine 30. The jig device 10 comprises a clamp 12 for holding the knife blade 20. The clamp 12 has first and second branches 12A and 12B, respectively. The first and second branches 12A, 12B are joined by a bend 12C. The first branch 12A comprises a backside 12A' and a distal end 12A'' adapted to support an edge of the knife blade 20. The jig device 10 also comprises a jig arm 11, or jig member. The jig arm 11 comprises an abutment surface 11' for the clamp 12. As is schematically illustrated in figure 5, essentially the entire length of the backside 12A' of the first branch 12A of the clamp 12 may abut against the abutment surface 11' of the jig arm 11. The backside 12A' of the clamp 12 may e.g. be removably or irremovably attached to the abutment surface 11' of the jig arm 11. The jig arm 11 further comprises attachment means 13, here exemplified by a hole 13 (see also Figs. 7A-7E), for removably or irremovably attaching the jig arm 11 to the support structure 32 of the grinding machine 30. Furthermore, the backside 12A' of the clamp 12 is oriented, or positioned, relative to the attachment means 13 of the jig arm 11 such that the distal end 12A'' of the first branch 12A of the clamp 12 faces the grindstone 31 of the grinding machine 30, in operation. As will be appreciated, the backside 12A' of the first branch 12A should preferably be oriented relative to the jig arm 11 such that the distal end 12A'' of the first branch 12A is adapted to be placed tangentially to the grindstone 31 and to face, or point, towards a direction that is essentially opposite to the direction of rotation of the grindstone 31 during operation.

The clamp 12 is made of pliable material, such as a pliable polymer material. Hereby it is made possible to achieve a clamp 12 with resilient properties. The pliable polymer material may e.g. be an Acrylonitrile Butadiene Styrene (ABS) plastic. Other pliable materials with resilient properties are of course also conceivable. As will be appreciated, the clamp 12 may be injection moulded. The resilient properties inherent in the clamp 12 may for example enable reception and fixing of knife blades 20 of different blade thicknesses.

The jig arm 11 is made of rigid material, such as a metal. Hereby it is made possible to provide a stable support of the knife blade 20, in operation. The metal may e.g. be a metal alloy. The jig arm 11 may hence be made of Zinc, Aluminum, steel, brass or cast iron to name a few example materials. Other rigid materials (e.g., rigid polymer materials) are of course also conceivable.

As can be seen in figure 6, the edge of the knife blade 20 can be positioned tangentially to and at the rotatable grindstone 31. A resilient portion 12B' at the distal end of the second branch 12B of the clamp 12 may be used to position the knife blade 20 at the rotatable grindstone 31 prior to the grinding operation. For example, a knife blade 20 may be inserted sideways into the clamp 12. To this end, the resilient properties of the clamp 12 also facilitate the positioning of the knife blade 20 inside the clamp 12. In operation, a backside of the knife blade may be controlled by the clamp 12 at points A and B, respectively, i.e. at points where the clamp 12 is stable and exhibits minimal, or at least limited, resilient properties. At the same time, the edge of the knife blade 20 may be controlled by the clamp 12 at points C and D, respectively. Point C is positioned at the distal end 12A'' of the first branch 12A of the clamp 12. Point D is positioned at the grindstone 31. More specifically, point D is positioned at an abutment point of the grindstone 31, i.e. a point of the grindstone 31 at which the edge of the knife blade 20 is abutting during operation.

The resilient properties of the clamp 12 of the jig device 10 may enable reception and resilient fixing of the knife blade 20 before a grinding operation. In operation, the stable support provided by the rigid properties of the jig arm 11 may enable controlled engagement of the edge of the knife blade 20 with the rotatable grindstone 31 of the grinding machine 30. Accordingly, a jig device 10 which is

relatively easy to use is provided. The jig device 10 according to the various embodiments disclosed herein is therefore less dependent on the skill of the user, or operator. Moreover, the resilient fixing of a knife blade in the clamp 12 may enable the user to tilt the knife blade 20 during operation so as to get a desired grinding of the edge of the knife blade 20. Hence, the use of the jig device 10 according to the various
5 embodiments disclosed herein may also lead to improved grinding results.

With reference to Figs. 7A-7E, the jig device 10 according to certain embodiments will be described in more detail. As described hereinabove, the jig arm 11 of the jig device 10 comprises attachment means 13. The attachment means 13 may
10 include a hole 13 for engagement with a support bar 32B, e.g. a generally cylindrical rod, of the support structure 32 (see e.g. figures 1-6). In advantageous embodiments, the attachment means may additionally comprise a knob 15, or other fastening member, for fastening the jig device 10 to the support bar 32B of the support structure 32. For example, a threaded pin with the knob 15 may be received in a threaded bore at the hole
15 13 so that the jig arm 11 of the jig device 10 may be fastened to the support bar 32B in a desired position. Hence, the hole 13 and the knob 15 may together form attachment means for removably or irremovably attaching the jig device 10 to the support structure 32 of the grinding machine 30.

In some embodiments, the attachment means may also comprise a protruding
20 member 14 for engagement with the support member 32A of the support structure 32. In the illustrated embodiment, the protruding member 14 has a bent shape. The bent shape may be arch-shaped. The protruding member 14, which is typically (but not necessarily) made of a rigid material such as a rigid polymer material, is adapted to engage with a corresponding bent shape of the support member 32A in a male-female connection
25 manner.

In some embodiments, the jig arm 11 of the jig device 10 is also optionally provided with a scale 11A (see also figures 1-6) with desired angles for the grinding of the knife blade 20 to be sharpened. As can be seen in the figures, a pointer towards the scale may also be provided to facilitate the adjustment of the desired angle. When fitted
30 into the support member 32A at the grinding machine 30 and by positioning the protruding member 14 in locked engagement with the support member 32A of the

support structure 32, the protruding member 14 may be used to assist the user, or operator, to adjust the desired angle for the grinding operation. With continued reference to figure 6, when the protruding member 14 is fitted into the support member 32A at the grinding machine 30, a user may for example apply a force to the jig device 5 10 to rotate the jig device 10 clockwise or counterclockwise around a rotational axis of the support bar 32B and thereby adjust the desired angle of grinding. During the adjustment of the angle, the scale 11A may assist the user in finding the desired angle and the protruding member 14 engages with the support member 32A to assist the user in setting the desired angle.

10 In some advantageous embodiments, the clamp 12 of the jig device 10 advantageously also comprises a waste material collecting means 16 adapted to collect waste material from the knife blade 20 during a grinding operation. The waste material collecting means 16 is positioned at the second branch 12B of the clamp 12. Furthermore, the waste collecting means 16 is positioned to face the rotatable 15 grindstone 31 in operation. In one embodiment, which is best illustrated in figures 3 and 5, the waste material collecting means 16 comprises a magnetic element 16'. The magnetic element 16' is adapted to collect waste material from the knife blade 20 by means of a magnetic attraction arising between the magnetic element 16' and any waste material resulting from the sharpened knife blade 20 during a grinding operation. The 20 provision of a waste material collecting means 16 may facilitate for the user to keep the grinding machine 10 clean. Also, an area surrounding the grinding machine 10 may be kept cleaner.

An advantage with the jig device according to the various embodiments described herein is that a knife blade can be easily and resiliently fixed in the clamp of 25 the jig device. Also, the position of the jig device in relation to the grindstone may still be controllable. Still further, the stable support provided by the rigid properties of the jig arm of the jig device may enable controlled engagement of the edge of the knife blade with the rotatable grindstone of the grinding machine.

30 In contrast to existing jig devices, the various embodiments of the jig device described herein comprises a clamp with resilient properties which allow for easily mounting of the knife blade into the clamp. At the same time, the rigid properties

provided by the jig arm provide a stable support during a grinding operation such that it is possible to achieve sufficient stability during a grinding operation. Accordingly, it is possible to achieve a desired result with regard to the evenness and accuracy of the grinding of the knife blade. In other words, the various embodiments of the jig device
5 may allow for improved grinding results. Moreover, the use the jig device is relatively simple. Accordingly, the use of the jig device is not necessarily dependent on the skill of the user, or operator. Yet further, the design of the jig device is simple and, thus, also relatively inexpensive to manufacture.

Modifications are possible within the scope of the appended claims.
10 Modifications and other variants of the described embodiments will thus come to mind to one skilled in the art having benefit of the teachings presented in the foregoing description and associated drawings. For example, while the embodiments described herein have mainly discussed jig devices for knives those skilled in the art will readily appreciate that the jig device can equivalently be used for other grindable objects too,
15 e.g. scissors. Therefore, it is also to be understood that the embodiments are not limited to the specific example embodiments described in this disclosure and that modifications and other variants are intended to be included within the scope of this disclosure. Furthermore, although specific terms may be employed herein, they are used in a generic and descriptive sense only and not for purposes of limitation. Therefore, a
20 person skilled in the art would recognize numerous variations to the described embodiments that would still fall within the scope of the appended claims. As used herein, the terms “comprise/comprises” or “include/includes” do not exclude the presence of other elements or steps. Furthermore, although individual features may be included in different claims, these may possibly advantageously be combined, and the
25 inclusion of different claims does not imply that a combination of features is not feasible and/or advantageous. In addition, singular references do not exclude a plurality.

CLAIMS

1. A jig device (10) for bringing a knife blade to be sharpened into controlled engagement with a grindstone (31) of a grinding machine (30), the jig device
5 (10) comprising:

a clamp (12) for holding a knife blade, the clamp (12) comprising a first and a second branch (12A, 12B) joined by a bend (12C), said first branch (12A) comprising a backside (12A') and a distal end (12A'') adapted to support the edge of the knife blade in a grinding operation; and

10 a jig arm (11) having an abutment surface (11') for the clamp (12) and attachment means (13) for attaching the jig arm (11) to a support structure (32) of a grinding machine; wherein

the clamp (12) is made of pliable material and the jig arm (11) is made of rigid material, such that the knife blade can be held firmly and resiliently in the
15 jig device (10), and wherein the backside (12A') of the clamp (12) is attached to the abutment surface (11') of the jig arm (11) and is further positioned relative to the attachment means (13) of the jig arm (11) such that the distal end (12A'') of the first branch (12A) of the clamp (12) can face the grindstone (31) of a grinding machine (30) in operation.

20

2. The jig device (10) according to claim 1, wherein essentially the entire length of the backside (12A') of the first branch (12A) abuts against the abutment surface (11') the jig arm (11).

25 3. The jig device (10) according to claim 1 or 2, wherein the backside (12A') of the first branch (12A) is oriented relative to the jig arm (11) such that the distal end (12A'') of the first branch (12A) is adapted to be placed tangentially to the grindstone (31) and to face towards a direction that is essentially opposite to a direction of rotation of the grindstone (31) during operation.

30

4. The jig device (10) according to any one of the claims 1-3, wherein the attachment means (13) comprise:
a hole (13) for engagement with a support bar (32B) of the support structure (32).
- 5
5. The jig device (10) according to claim 4, wherein the attachment means additionally comprise:
a protruding member (14) for engagement with a support member (32A) of the support structure (32) and for positioning the jig device (10) relative to the grindstone (31); and
a threaded pin with a knob (15), positioned at the hole (13), for fastening the jig device (10) to the support bar (32B) of the support structure (32).
- 10
6. The jig device (10) according to claim 5, wherein the protruding member (14) has a bent shape which is adapted to engage with a corresponding bent shape of the support member (32A) in a male-female connection manner.
- 15
7. The jig device (10) according to claim 6, wherein the protruding member (14) is made of a rigid polymer material.
- 20
8. The jig device (10) according to claim 6 or 7, wherein the jig arm (11) is provided with a scale (11A) with desired angles for the grinding of the knife blade (20) to be sharpened, and wherein the protruding member (14) is adapted to assist in adjusting the desired angle when the protruding member (14) is positioned in locked engagement with the support member (32A) of the support structure (32).
- 25
9. The jig device (10) according to any one of the claims 1-8, wherein the pliable material is a resilient material.
- 30
10. The jig device (10) according to claim 9, wherein the resilient material is a polymer material having resilient properties.

11. The jig device (10) according to any one of the claims 1-10, wherein the rigid material is a metal.
- 5 12. The jig device (10) according to any one of the claims 1-11, wherein the clamp (12) comprises a waste material collecting means (16) adapted to collect waste material from the knife blade (20) during operation.
- 10 13. The jig device (10) according to claim 12, wherein the waste material collecting means (16) is positioned at the second branch (12B) of the clamp (12).
14. The jig device (10) according to claim 13, wherein the waste collecting means (16) is positioned to face the rotatable grindstone (31) in operation.
- 15 15. The jig device (10) according to any one of the claims 12-14, wherein the waste collecting means (16) comprises a magnetic element (16') adapted to collect waste material from the knife blade (20) by means of magnetic attraction arising between the magnetic element (16') and any waste material resulting from a knife blade (20) being sharpened during operation.
- 20 16. A grinding machine (30) comprising a rotatable grindstone (31) and a support structure (32), wherein the jig device (10) according to any one of the claims 1-15 is removably or irremovably attached to the support structure (32) such that the jig device (10) can be placed tangentially to and closely over, or at, the grindstone (31) in operation, and wherein
- 25 the support structure (32) comprises a support member (32A) fixed to the grinding machine (30) and extending in a direction (D1) which is substantially perpendicular to a rotational axis (R) of the grindstone (31), and a support bar (32B) attached to the support member (32A) and extending in a direction (D2)
- 30 which is substantially parallel with the rotational axis (R) of the grindstone (31).
17. The grinding machine (30) according to claim 16, wherein the support member (32A) has a bent shape.

18. The grinding machine (30) according to claim 17, wherein the bent shape is arch-shaped.
- 5 19. The grinding machine (30) according to claim 18, wherein the support member (32A) includes an arch (32A'), which extends upwardly relative to a surface (33) where the support member (32A) is fixed to the grinding machine (30).
- 10 20. The grinding machine (30) according to claim 19, wherein the support bar (32B) is attached to the support member (32A) at the distal end of the support member (32A).
- 15 21. The grinding machine (30) according to any one of the claims 16-20, when dependent on claim 6, 7 or 8, wherein the support member (32A) having the bent shape is further adapted to receive the protruding member (14) of the jig arm (11) such that the jig arm (11) can be releasably locked to the support member (32A) in a male-female connection manner and positioned relative to the grindstone (31).
- 20 22. The grinding machine (30) according to any one of the claims 16-21, wherein the support bar (32B) is an essentially cylindrical rod.

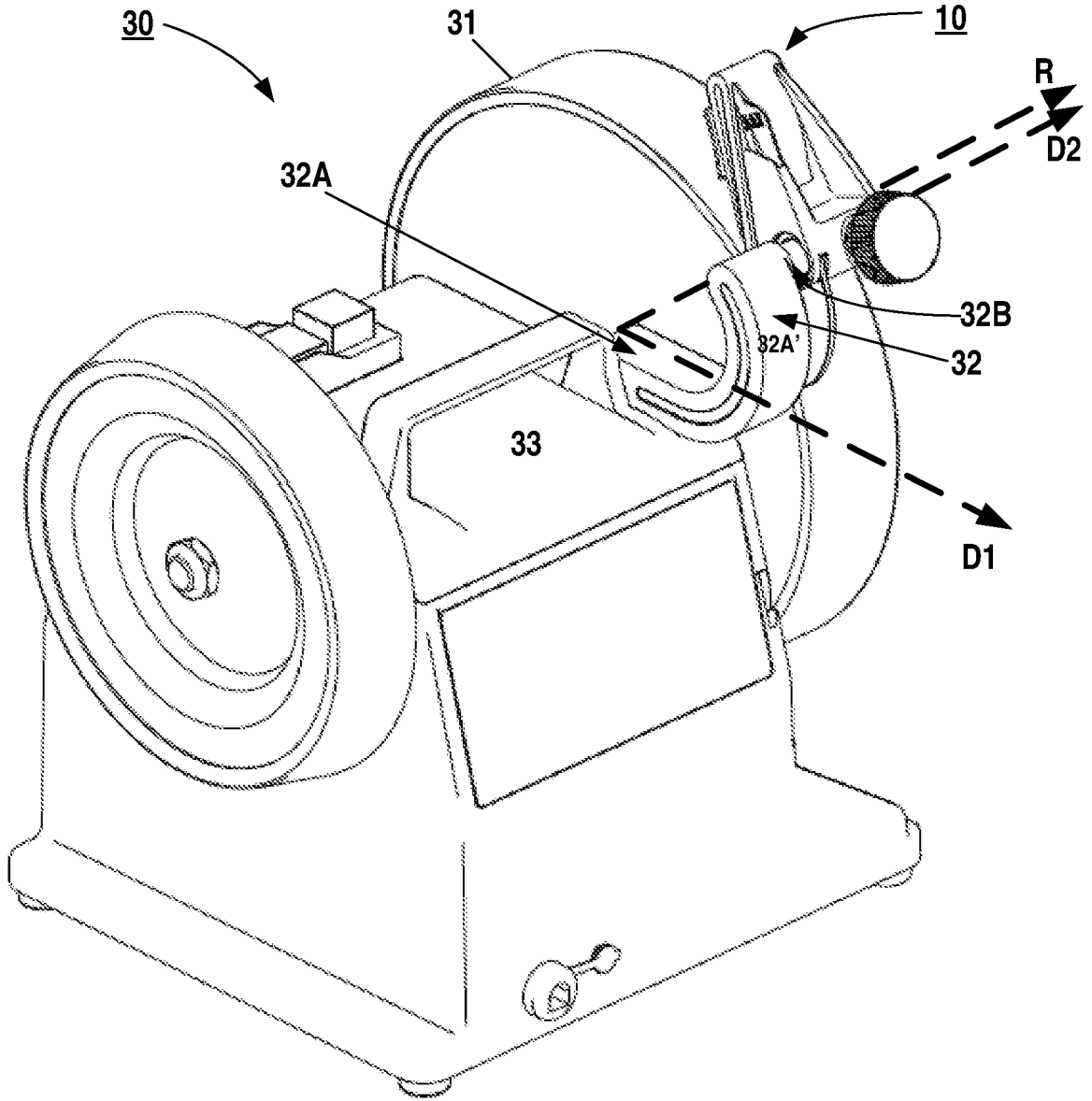

Figure 1

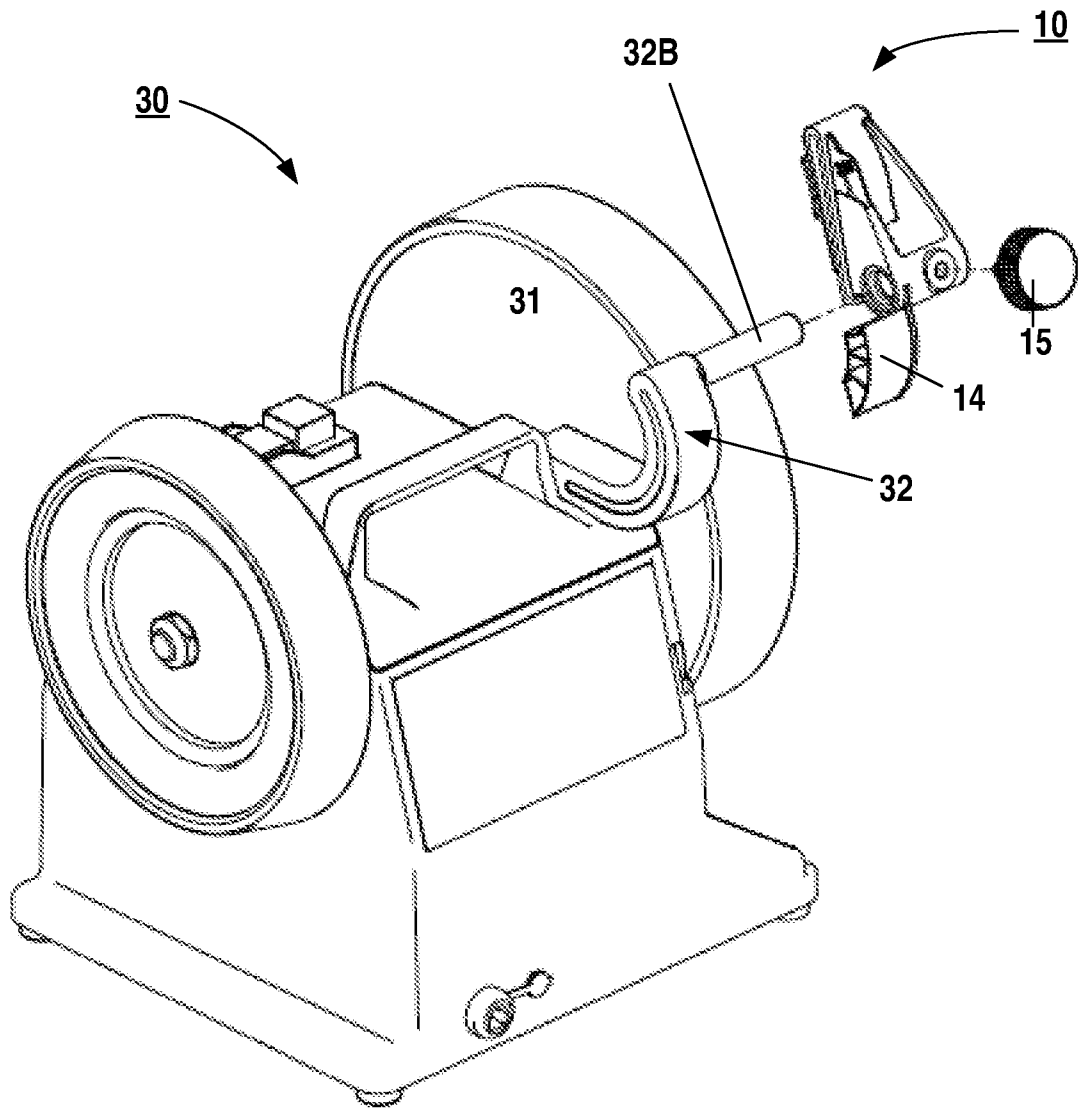

Figure 2

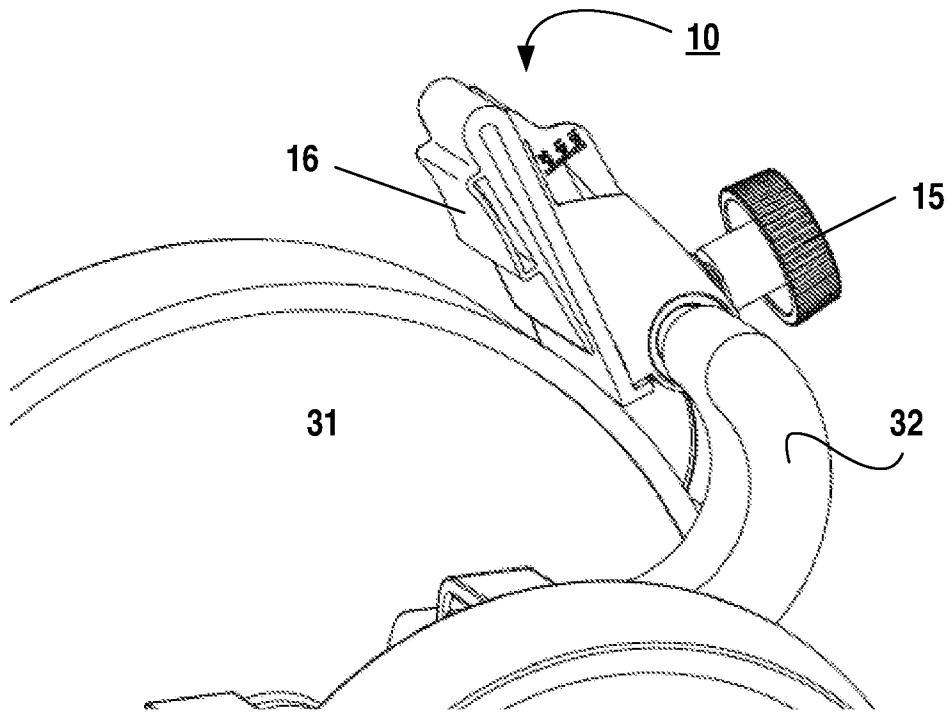

Figure 3

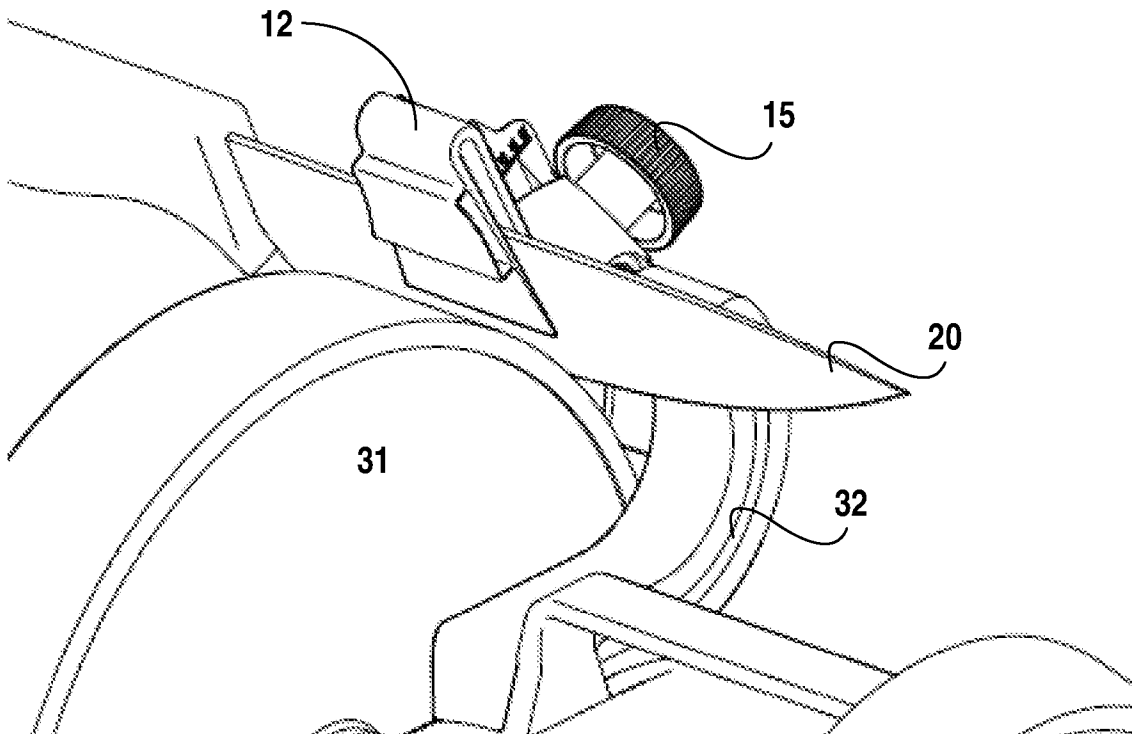

Figure 4

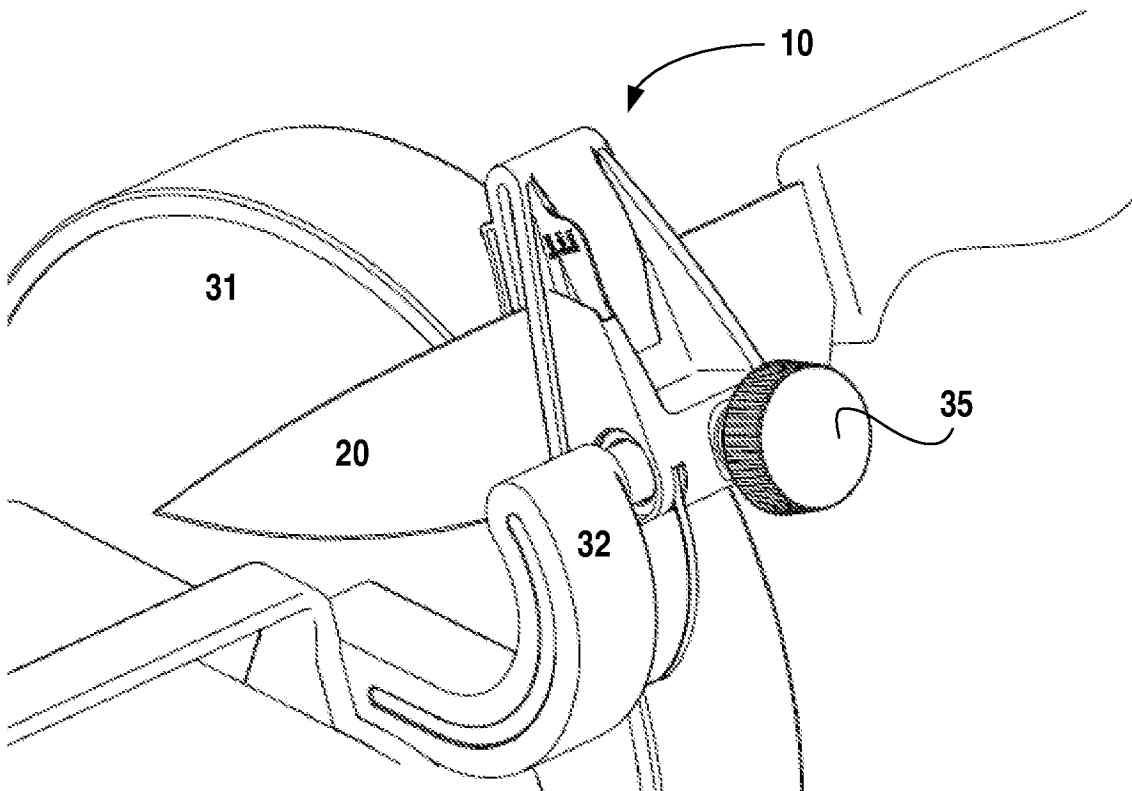

Figure 5

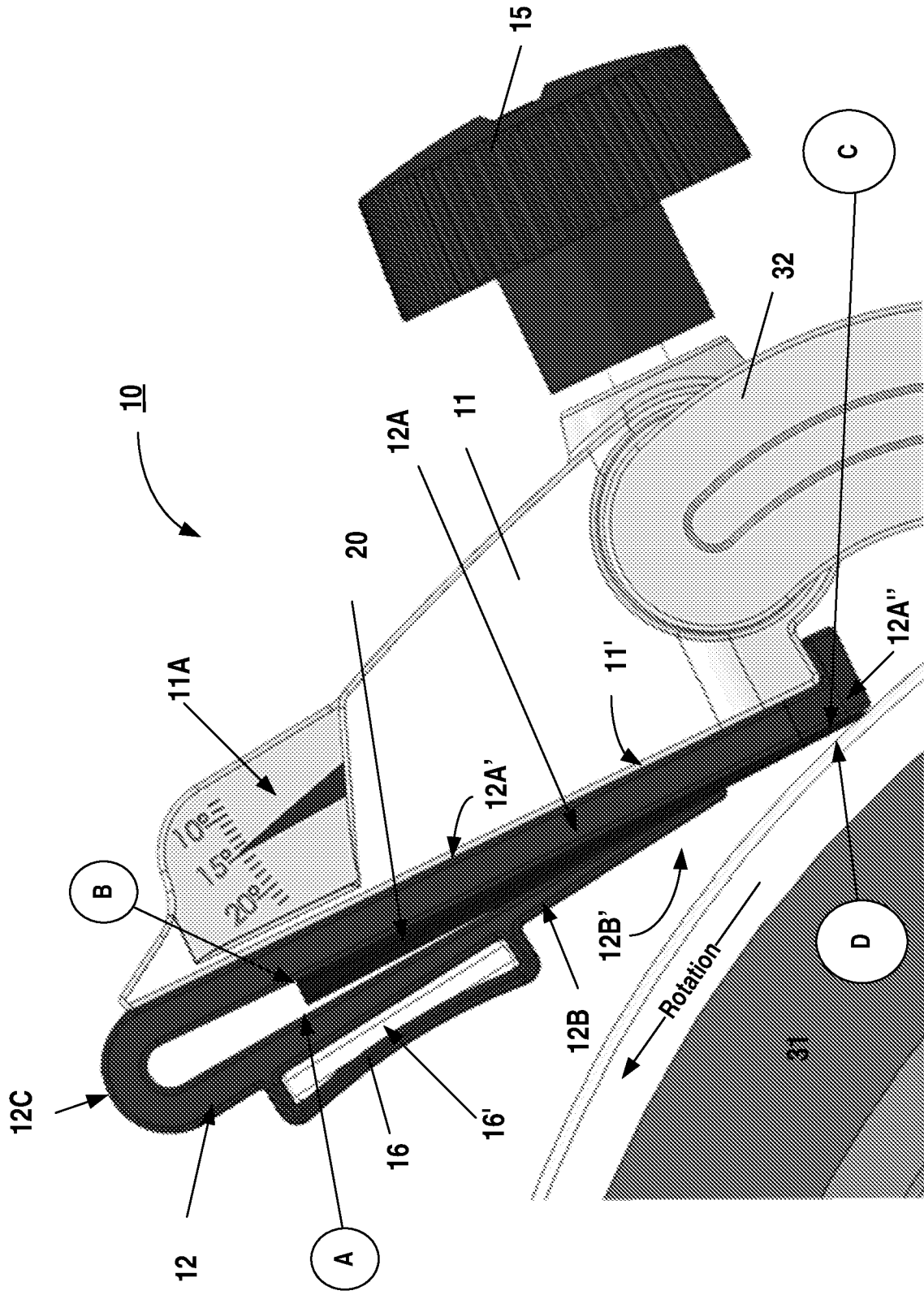

Figure 6

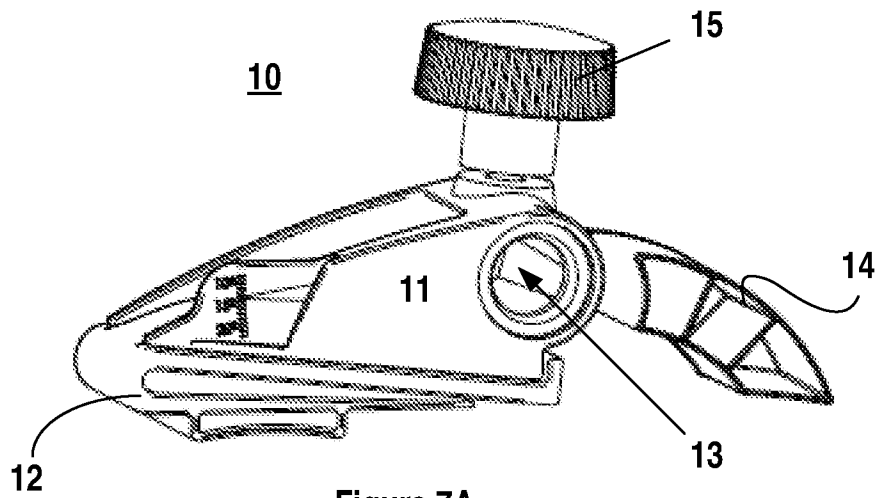

Figure 7A

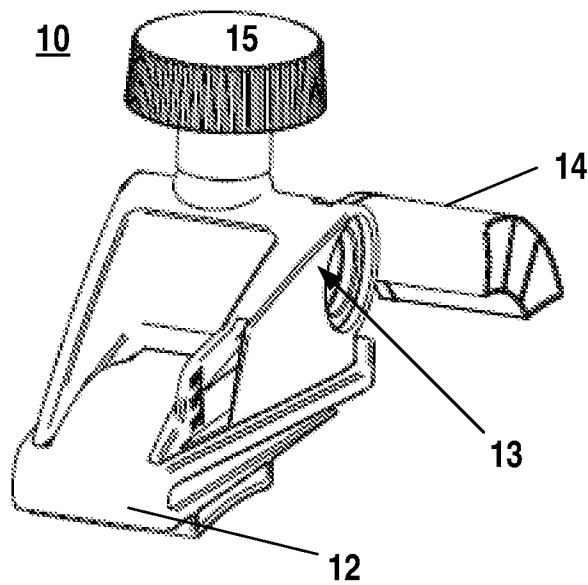

Figure 7B

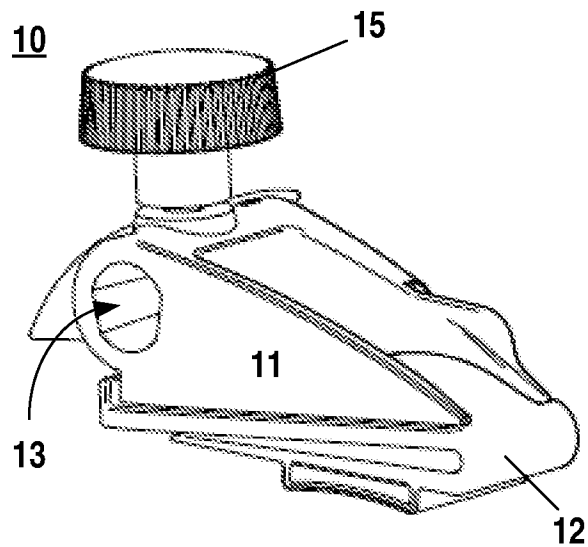

Figure 7C

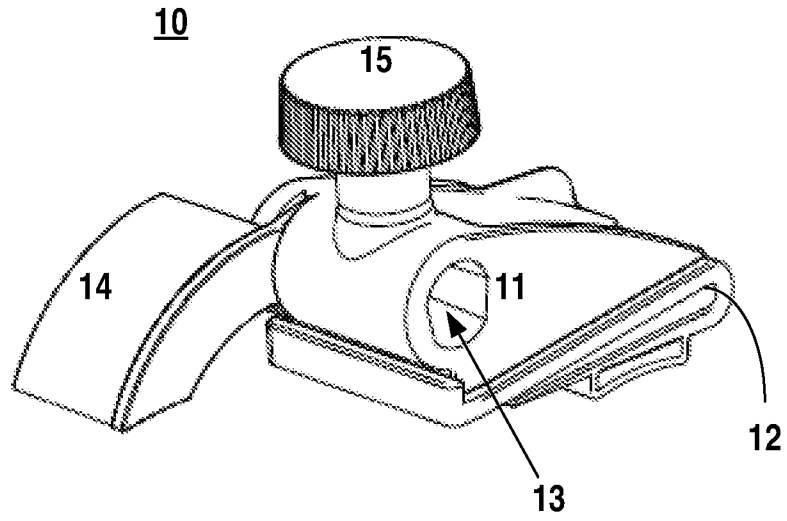

Figure 7D

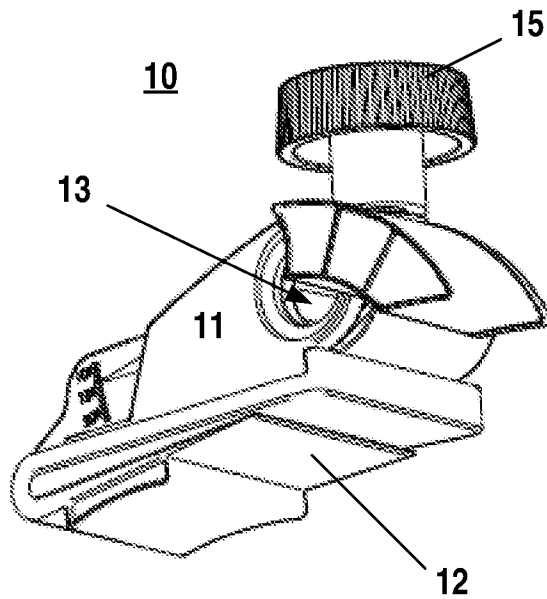

Figure 7E

INTERNATIONAL SEARCH REPORT

International application No.
PCT/SE2016/050476

A. CLASSIFICATION OF SUBJECT MATTER

IPC: see extra sheet

According to International Patent Classification (IPC) or to both national classification and IPC

B. FIELDS SEARCHED

Minimum documentation searched (classification system followed by classification symbols)

IPC: B23Q, B24B

Documentation searched other than minimum documentation to the extent that such documents are included in the fields searched

SE, DK, FI, NO classes as above

Electronic data base consulted during the international search (name of data base and, where practicable, search terms used)

EPO-Internal, PAJ, WPI data

C. DOCUMENTS CONSIDERED TO BE RELEVANT

Category*	Citation of document, with indication, where appropriate, of the relevant passages	Relevant to claim No.
P, X	EP 2883655 A1 (TORMEK AB), 17 June 2015 (2015-06-17); abstract; paragraphs [0001]-[0011], [0013]-[0020], [0027]-[0042]; figures 1-8; claims 1-9,10-15; see especially paragraphs 0038-0042, figs. 6-8.	1-4, 7-11
P, A	--	5-6, 12-22
A	WO 9733717 A1 (LIEN HELGE), 18 September 1997 (1997-09-18); abstract; page 5, line 24 - page 6, line 25; figures 1-2	3
A	WO 9956915 A1 (PRETORIUS STEPHAN DEON ET AL), 11 November 1999 (1999-11-11); abstract; figures 1-6	1-22

 Further documents are listed in the continuation of Box C. See patent family annex.

* Special categories of cited documents:

"A" document defining the general state of the art which is not considered to be of particular relevance

"E" earlier application or patent but published on or after the international filing date

"L" document which may throw doubts on priority claim(s) or which is cited to establish the publication date of another citation or other special reason (as specified)

"O" document referring to an oral disclosure, use, exhibition or other means

"P" document published prior to the international filing date but later than the priority date claimed

"T" later document published after the international filing date or priority date and not in conflict with the application but cited to understand the principle or theory underlying the invention

"X" document of particular relevance; the claimed invention cannot be considered novel or cannot be considered to involve an inventive step when the document is taken alone

"Y" document of particular relevance; the claimed invention cannot be considered to involve an inventive step when the document is combined with one or more other such documents, such combination being obvious to a person skilled in the art

"&" document member of the same patent family

Date of the actual completion of the international search

24-08-2016

Date of mailing of the international search report

26-08-2016

Name and mailing address of the ISA/SE

Patent- och registreringsverket
Box 5055
S-102 42 STOCKHOLM
Facsimile No. + 46 8 666 02 86

Authorized officer

Barbara Silén

Telephone No. + 46 8 782 28 00

INTERNATIONAL SEARCH REPORT

International application No.
PCT/SE2016/050476

C (Continuation). DOCUMENTS CONSIDERED TO BE RELEVANT

Category*	Citation of document, with indication, where appropriate, of the relevant passages	Relevant to claim No.
A	SE 8306325 L (TORGNY JANSSON, TORMEK), 22 May 1985 (1985-05-22); abstract --	1-22
A	JP 2010260128 A (TAKAHASHI YUJI), 18 November 2010 (2010-11-18); abstract; figure 1 --	1-22
A	US 6676495 B1 (SIEMERS MATTHEW BRUCE ET AL), 13 January 2004 (2004-01-13); abstract; figures 1-2,4,8-11 -- -----	1-22

Continuation of: second sheet

International Patent Classification (IPC)

B24B 3/54 (2006.01)

B23Q 3/06 (2006.01)

B24B 3/36 (2006.01)

B24B 41/06 (2012.01)

INTERNATIONAL SEARCH REPORT

Information on patent family members

International application No.

PCT/SE2016/050476

EP	2883655 A1	17/06/2015	US	20150165582 A1	18/06/2015
WO	9733717 A1	18/09/1997	AU	2413397 A	01/10/1997
			NO	301528 B1	10/11/1997
			NO	961064 A	16/09/1997
WO	9956915 A1	11/11/1999	AT	273107 T	15/08/2004
			AU	4102999 A	23/11/1999
			CA	2331369 A1	11/11/1999
			DE	69919345 D1	16/09/2004
			EP	1075356 A1	14/02/2001
SE	8306325 L	22/05/1985	NONE		
JP	2010260128 A	18/11/2010	NONE		
US	6676495 B1	13/01/2004	NONE		