

**(12) STANDARD PATENT**  
**(19) AUSTRALIAN PATENT OFFICE**

(11) Application No. **AU 2005297563 B2**

(54) Title  
**Automatic dispensing device for laundry care composition**

(51) International Patent Classification(s)  
**D06F 39/02** (2006.01)

(21) Application No: **2005297563** (22) Date of Filing: **2005.09.27**

(87) WIPO No: **WO06/042631**

(30) Priority Data

(31) Number	(32) Date	(33) Country
<b>10/967,870</b>	<b>2004.10.18</b>	<b>US</b>

(43) Publication Date: **2006.04.27**

(44) Accepted Journal Date: **2009.07.09**

(71) Applicant(s)  
**Unilever PLC**

(72) Inventor(s)  
**Hsu, Feng-Lung G;Vogel, Ronald F;Hsu, Gary C;Wolf, Diane N;Puvvada, Sudhakar**

(74) Agent / Attorney  
**Davies Collison Cave, 255 Elizabeth Street, Sydney, NSW, 2000**

(56) Related Art  
**US 4981024**  
**US 3982666**  
**US 4103520**

(19) World Intellectual Property Organization  
International Bureau



(43) International Publication Date  
27 April 2006 (27.04.2006)

PCT

(10) International Publication Number  
**WO 2006/042631 A1**

- (51) International Patent Classification:  
*D06F 39/02* (2006.01)
- (21) International Application Number:  
PCT/EP2005/010573
- (22) International Filing Date:  
27 September 2005 (27.09.2005)
- (25) Filing Language: English
- (26) Publication Language: English
- (30) Priority Data:  
10/967,870 18 October 2004 (18.10.2004) US
- (71) Applicant (for AL, AM, AT, AZ, BA, BE, BF, BG, BJ, BR, BY, CF, CG, CH, CI, CM, CN, CO, CR, CU, CZ, DE, DK, DM, DZ, EC, EE, ES, FI, FR, GA, GE, GN, GQ, GR, GW, HR, HU, ID, IS, IT, JP, KG, KM, KP, KR, KZ, LR, LT, LU, LV, MA, MC, MD, MG, MK, ML, MR, MX, MZ, NE, NI, NL, NO, PH, PL, PT, RO, RU, SE, SI, SK, SM, SN, SY, TD, TG, TJ, TM, TN, TR, UA, UZ, VN, YU only): **UNILEVER N.V.** [NL/NL]; Weena 455, NL-3013 AL Rotterdam (NL).
- (71) Applicant (for AE, AG, AU, BB, BW, BZ, CA, CY, EG, GB, GD, GH, GM, IE, IL, KE, LC, LK, LS, MN, MW, NA, NG, NZ, OM, PG, SC, SD, SG, SL, SZ, TT, TZ, UG, VC, ZA, ZM, ZW only): **UNILEVER PLC** [GB/GB]; Unilever House, Blackfriars, London Greater London EC4P 4BQ (GB).
- (71) Applicant (for IN only): **HINDUSTAN LEVER LIMITED** [IN/IN]; Hindustan Lever House, 165/166 Backbay Reclamation Maharashtra, Mumbai 400 020 (IN).
- (72) Inventors; and
- (75) Inventors/Applicants (for US only): **HSU, Feng-Lung, G** [US/US]; Unilever Home & Personal Care USA, Research & Development, 40 Merritt Boulevard, Trumbull, Connecticut 06611 (US). **PUVVADA, Sudhakar** [US/GB]; Unilever R & D Port Sunlight, Quarry Road East, Bebington, Wirral Merseyside CH63 3JW (GB). **VOGEL, Ronald, F** [US/US]; Unilever R & D Edgewater, 45 River Road, Edgewater, New Jersey 07020 (US). **WOLF, Diane, N** [US/US]; Unilever Home & Personal Care USA, 45 River Road, Edgewater, New Jersey 07020 (US). **HSU, Gary, C** [US/US]; Unilever R & D Edgewater, 45 River Road, Edgewater, New Jersey 07020 (US).
- (74) Agent: **ROSEN JACOBSON, Frans, L, M**; Unilever Intellectual Property Group, Olivier van Noortlaan 120, NL-3133 AT Vlaardingen (NL).
- (81) Designated States (unless otherwise indicated, for every kind of national protection available): AE, AG, AL, AM, AT, AU, AZ, BA, BB, BG, BR, BW, BY, BZ, CA, CH, CN, CO, CR, CU, CZ, DE, DK, DM, DZ, EC, EE, EG, ES, FI, GB, GD, GE, GH, GM, HR, HU, ID, IL, IN, IS, JP, KE,

[Continued on next page]

(54) Title: AUTOMATIC DISPENSING DEVICE FOR LAUNDRY CARE COMPOSITION

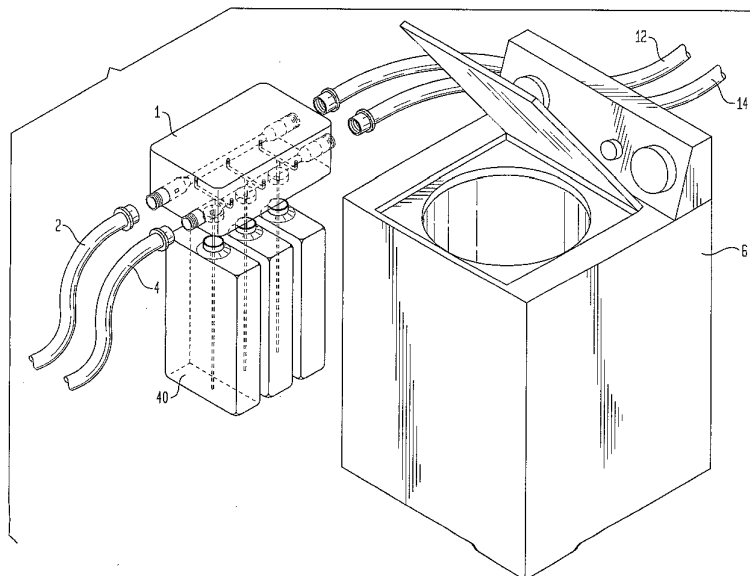

(57) Abstract: A non-intrusive device for automatically dosing at least one liquid laundry care composition to an automatic laundry washing machine. The device employs a Venturi tube mechanism or a pump to dose the laundry detergent care composition. The dosing is controlled by a machine-generic algorithm capable of determining the actual cycle at any duration of wash for various cycle designs from various washing machines, without the input of precise cycle design; and dose the correct products correctly and is capable of distinguishing between major water addition and a water pulse.

WO 2006/042631 A1



KG, KM, KP, KR, KZ, LC, LK, LR, LS, LT, LU, LV, LY, MA, MD, MG, MK, MN, MW, MX, MZ, NA, NG, NI, NO, NZ, OM, PG, PH, PL, PT, RO, RU, SC, SD, SE, SG, SK, SL, SM, SY, TJ, TM, TN, TR, TT, TZ, UA, UG, US, UZ, VC, VN, YU, ZA, ZM, ZW.

- (84) **Designated States** (unless otherwise indicated, for every kind of regional protection available): ARIPO (BW, GH, GM, KE, LS, MW, MZ, NA, SD, SL, SZ, TZ, UG, ZM, ZW), Eurasian (AM, AZ, BY, KG, KZ, MD, RU, TJ, TM), European (AT, BE, BG, CH, CY, CZ, DE, DK, EE, ES, FI,

FR, GB, GR, HU, IE, IS, IT, LT, LU, LV, MC, NL, PL, PT, RO, SE, SI, SK, TR), OAPI (BF, BJ, CF, CG, CI, CM, GA, GN, GQ, GW, ML, MR, NE, SN, TD, TG).

**Published:**

— with international search report

*For two-letter codes and other abbreviations, refer to the "Guidance Notes on Codes and Abbreviations" appearing at the beginning of each regular issue of the PCT Gazette.*

AUTOMATIC DISPENSING DEVICE FOR  
LAUNDRY CARE COMPOSITION

## FIELD OF THE INVENTION

5 Automatic, electronically-controlled dispensing device for dispensing laundry care composition into an automatic laundry washing machine, and methods for use thereof.

## BACKGROUND OF THE INVENTION

10 Detergent compositions are provided in many forms, of which granular and liquid compositions are the most prevalent. More recently, unit dose forms of detergent have been proposed in the form of compressed tablets of detergent powder or water-soluble packages, which are consumed during a single cleaning  
15 application. The unit dose forms are preferred by some consumers, in that the dose is pre-measured and, consequently, the unit dose form is faster, easier and less messy to use. The unit dose forms, however, involve complexities in manufacture. Furthermore, unit dose detergents do not allow  
20 for variations in dosing, depending on water fill level in the machine.

Various devices for delivering ingredients in a controllable way to washing machines have been described. See, for instance  
25 US 4,981,024, US 3,982,666, US 3,881,328, US 4,103,520, US 4,932,227, EP 0611,159, US 5,207,080, US 2003/0116177, US 4,103,520, EP 1088927, WO 03/033804, US 2004/088796, WO 03/069043, US 2003/0182732, and GB 2 134 078. The need continues to exist, however, for an improved automatic laundry  
30 care dosing device.

## SUMMARY OF THE INVENTION

The present invention includes, in its first embodiment, a non-intrusive device for automatically dosing at least one liquid laundry care composition to an automatic laundry washing machine, the device located along water supply feed to the washing machine with an incoming water supply feed to the device and outgoing water supply feed out of the device, the device comprising:

- 10 - a Venturi tube, the both ends of the tube protruding externally to the housing of the device for connections to the incoming and the outgoing water supply feed,
- 15 - a dosing container for holding the laundry care composition, the throat of the Venturi tube connected by a conduit to the dosing container;
- a sensor for determining water flow from the water supply, the sensor located at a water supply feed and connected to
- 20 - an electronic circuit containing a clock and a processing unit programmed with a machine-generic algorithm to control
- 25 - a solenoid valve, coupled to the same circuit and located within the conduit connecting the Venturi tube and the dosing container, the valve opening or closing the flow of the laundry care composition from the dosing container.

In its second embodiment, the invention includes the variation wherein the mechanical pump is employed to dose the detergent, in place of a Venturi tube mechanism.

The inventive device is suitable for residential washing machines, as well as industrial, or commercial washing machines. The inventive device is suitable for use with front-loading or top-loading washing machines.

5

According to another aspect the present invention provides a non-intrusive device for automatically dosing at least one liquid laundry care composition to an automatic laundry washing machine, the device located along water supply feed to the washing machine with an incoming water supply feed to the device and outgoing water supply feed out of the device, the device comprising:

- 15 - a Venturi tube, the both ends of the tube protruding externally to the housing of the device for connections to the incoming and the outgoing water supply feed,
- a dosing container for holding the laundry care composition, the throat of the Venturi tube connected by a conduit to the dosing container;
- 20 - a sensor for determining water flow through the incoming water supply feed, the sensor located at the incoming water supply feed and connected to
- an electronic circuit containing a clock and a processing unit programmed with a machine-generic algorithm to control
- 25 - a solenoid valve, coupled to the same circuit and located within the conduit connecting the Venturi tube and the dosing container, the valve opening or closing the flow of the laundry care composition from the dosing container,

30 wherein the algorithm is capable of determining the actual cycle at any duration of wash for various cycle designs from various washing machines, without the input of precise cycle

design; and dose the correct products.

According to another aspect the present invention provides a non-intrusive device for automatically dosing at least one  
5 liquid laundry care composition to an automatic laundry washing machine, the device located along water supply feed to the washing machine with an incoming water supply feed to the device and outgoing water supply feed out of the device, the device comprising:

- 10 - a water conduit tube, the both ends of the tube protruding externally to the device for connections to the incoming and outgoing water supply feed;
- a dosing container for holding the laundry care composition, the container connected by a conduit to  
15 the water conduit tube,
- a sensor for determining water flow through the incoming water supply feed, the sensor located at the incoming water supply feed and connected to
- an electronic circuit containing a clock and a  
20 processing unit programmed with a machine-generic algorithm to control
- a pump, coupled to the same circuit, the suction end of the pump connected by a conduit to the dosing container and the discharge end of the pump connected to the  
25 water supply feed,

wherein the algorithm is capable of determining the actual cycle at any duration of wash for various cycle designs from various washing machines, without the input of precise cycle design; and dose the correct products correctly.

30

The following detailed description and the drawings illustrate some of the effects of the inventive

compositions. The invention and the claims, however, are not limited to the following description and drawings.

#### BRIEF DESCRIPTION OF THE DRAWINGS

- 5 Figure 1 is a perspective view of an inventive device according to one of the embodiments of the invention, prior to installation on a conventional laundry washing machine; Figure 2 is a typical block diagrammatic view of the electronic circuit board design of the inventive device
- 10 according to a preferred embodiment of the invention; Figure 3 is an enlarged fragmentary view of the inventive device in Fig. 1; Figure 4 is an enlarged view of the Venturi tube mechanism of the device of Figure 1;
- 15 Figure 4A is an enlarged view of an alternative dosing mechanism of the device of Figure 1 (a pump in place of the Venturi tube mechanism); Figure 5 is a perspective view of the device in Fig. 1; Figures 6 and 7 are enlarged fragmentary views of the
- 20 inventive device according to other preferred embodiments of the invention; Figure 8 is an enlarged view of the Venturi tube mechanism of the device of Figure 6; Figure 9 is an enlarged fragmentary view of the inventive
- 25 device according to another preferred embodiment of the invention, employing a pump mechanism, in place of the Venturi tube mechanism;

Figures 10A, 10B, 11A and 11B are logic flow diagrams for algorithms according to the preferred embodiments of the invention.

5 It will be appreciated that for simplicity and clarity of illustration, elements shown in the drawings have not necessarily been drawn to scale. For example, the dimensions of some of the elements are exaggerated relative to each other. Further, where considered appropriate, reference numerals have  
10 been repeated among the Figures to indicate corresponding elements.

#### DETAILED DESCRIPTION OF THE INVENTION

Except in the operating and comparative examples, or where  
15 otherwise explicitly indicated, all numbers in this description indicating amounts of material or conditions of reaction, physical properties of materials and/or use are to be understood as modified by the word "about."

20 It should be noted that in specifying any range of time or physical conditions, any particular upper limit can be associated with any particular lower limit.

For the avoidance of doubt the word "comprising" is intended to  
25 mean "including" but not necessarily "consisting of" or "composed of." In other words, the listed steps or options or components need not be exhaustive.

"Liquid" as used herein means that a continuous phase or  
30 predominant part of the composition is liquid and that a composition is flowable at 20°C. Solids (e.g., suspended or other) may be included. Gels and pastes are included within the liquids as used herein.

"Venturi tube" as used herein means a pipe with a constricted inner surface (throat); fluid passing through the tube speeds up as it enters the tube's throat, and generating a vacuum,  
5 which causes the dosing of a laundry care composition from a laundry care container to the washing machine.

"Non-intrusive" as used herein means external to the washing machine; can be fitted to the washing machine machine by the  
10 user of the machine, without having to invade the machine housing in any way.

"Laundry care" as used herein means any and all compositions that may be used for the cleaning and care of laundry,  
15 including but not limited to detergents, bleach, softening, anti-wrinkling, etc. and any mixtures thereof.

"Along water supply feed" means that the device is connected to the washing machine via incoming and outgoing water supply  
20 hoses, into and out of the device, the outgoing water supply hoses then leading to the washing machine.

"Machine-generic algorithm" as used herein means an algorithm that is capable of determining the actual cycle at any duration  
25 of wash for various cycle designs from various washing machines, without the input of precise cycle design; and dose the correct products correctly.

"Major water addition" is the water fill with the amount that  
30 is sufficient to pre-wash, wash or rinse the articles that to be clean in one time.

"Incoming" and "outgoing" is used herein with reference to the inventive device, to indicate flow to and out of the device.

In the following detailed description of exemplary embodiments  
5 of the invention, reference is made to the accompanying  
drawings, which illustrate specific exemplary embodiments in  
which the invention may be practiced. These embodiments are  
described in sufficient detail to enable those skilled in the  
art to practice the invention, but other embodiments may be  
10 utilized and logical, mechanical, electrical, electronic and  
other changes may be made without departing from the scope of  
the present invention. The following detailed description is,  
therefore, not to be taken in a limiting sense, and the scope  
of the present invention is defined only by the appended  
15 claims.

In the following description, numerous specific details are set  
forth to provide a thorough understanding of the invention.  
However, it is understood that the invention may be practiced  
20 without these specific details. In other instances, well-know  
circuits, structures and techniques have not been shown in  
detail in order not to obscure the invention.

Turning now to the drawings, Figure 1 is a perspective view of  
25 a preferred embodiment of the inventive device 1 prior to the  
installation. Device 1 connects to the incoming (2, 4) and  
outgoing (12, 14) water supply hoses. The outgoing hoses 12  
and 14 connect the device to the washing machine 6. Typically,  
a pair of hoses is employed, with one connecting to hot water  
30 feed, and the other to the cold water feed. The number of the  
Venturi tubes within the device is generally the same as the  
number of water supply hoses. With a single water supply hose,  
the inventive device with a single Venturi tube is employed, as

shown in Figures 6-8. Typically, when installed, the device rests on top of the control panel 7 of the washing machine, to allow easy access to the display panel of the device, and for replacing/refilling the laundry care containers.

5

Figure 2 illustrates the typical design of the electronic circuit board 5 contained within the housing of the inventive device. The circuit board has a connector to one or more sensors (95 or 96); the sensor sends a signal to a control unit  
10 which indicates the flow of the water (on or off). The control unit contains a processing unit and a clock. In the illustrated embodiment, the clock is contained within the control unit. The control unit is further connected to the panel display and to one or more solenoid valves within the  
15 conduits connecting Venturi tubes with laundry care containers.

The processing unit is programmed with a machine-generic algorithm which processes the signal from the sensor, to control the opening or closing of the solenoid valves, at appropriate time points during the operation of the washing  
20 machine. The algorithm may be coded into a single electronic chip or a print circuit board, which is the major part of the processing unit.

The machine-generic algorithm is programmed to differentiate  
25 between a major water addition and a water pulse and to differentiate among various wash cycles. In the case of a major water addition, the algorithm determines the state of the wash process and passes the signal to open one or more of the solenoid valves corresponding to the correct products. When  
30 the solenoid valves are open, the vacuum provided by the flow of water through Venturi tubes allows the flow of one or more of the laundry care compositions to the water stream that is filling the wash machine. The algorithm can also be programmed

to open only the solenoid valve which is connected to the Venturi tube with the water flowing through it at that moment in order to prevent the cross-contamination between hot and cold water lines (which happens when both solenoid valves  
5 connected to both water lines are open). In other words, only one water supply (hot or cold) might be on, and that is the one that will prompt the appropriate solenoid valve to open.

Figures 3, 4 and 5 illustrate the mechanism of the dosing of a  
10 laundry care composition via a preferred embodiment of the inventive device 1. If the algorithm processes the instruction to mean that a major water addition is occurring via incoming hoses 2 and/or 4, the signal is sent from the control unit to the solenoid valves 32, and/or 52 and/or 62 to open (the  
15 solenoid valves being connected by wires 31 to the electronic circuit 5), which then results, due to the vacuum in the throats 30 of the Venturi tubes 10 and 20, in the flow of a laundry care composition out of the laundry care container 40.

The container 40 is shown elevated; in use it snaps down  
20 within the slot 42, so that the spout 38 fits to a conduit 35, sealed by O-ring 39. The laundry care composition flows down the spout 38, then down the conduits 35, 34, 33 and 32 (Fig. 4), mixing with the incoming water flow in the Venturi tubes, and exiting the dosing device via the outgoing water hoses 12  
25 and 14. The resulting water/laundry care mix is carried into the washing machine via hoses 12 and/or 14. The device in Figure 3 contains three laundry care containers 40, according to the most preferred embodiment of the invention, fitting within container slots 42. Depending on the instructions  
30 received from the algorithm (differentiating between the wash cycles), different sets of solenoid valves - 32, 52, or 62 - are open to allow various laundry care compositions to flow. Preferably, the inventive device contains a laundry detergent

container, a fabric softener/fabric care container, and/or a bleach or a laundry booster container.

The length of the throat portion of the Venturi tube is preferably from 1 to 20 cm, more preferably less than 10 cm, most preferably less than 5 cm. The multiple connections from the throat to the containers of laundry products may be distributed along the axial direction or/and the perimeter of the throat.

10

The preferred inventive devices contain a safety check assembly within the conduit 35. The safety assembly may be assembled in a variety of ways. One of the embodiments is shown in detail in Figure 4. The safety assembly prevents the flow of the laundry care composition down the conduit 35, if the solenoid valve is open (e.g. malfunctioning, stuck), but there is no water flow through the Venturi tubes. The safety assembly contains spring 36, upon which rests a ball 37. If there is no water flow through throats 30 of the Venturi tubes, there is no vacuum to force the flow of the laundry care composition down the spout 38, the spring 36 remains at rest, with the ball 37 blocking the flow of the composition. An O-ring 39 is seated on the outside of the conduit 38, below the top rim, to ensure a better seal between the spout 38 and the conduit 35.

25

Figure 4A illustrates another preferred embodiment (device 1A). It is preferred because only one solenoid valve or pump is employed. The other reason is that the safety valve is not open for the line which is without water flow. If the algorithm processes the instruction to mean that a major water addition is occurring via incoming hoses 2 and/or 4, the signal is sent from the control unit to the solenoid valve 32, which is located in the conduit 35, to open (the solenoid valve being

30

connected by wires 31 to the electronic circuit 5), which then results in the flow of a laundry care composition out of the laundry care container 40, down the spout 38, then down the conduits 35, 34, and 33. The check valve assemblies (spring 36 and ball 35) are located at the conduits 33, which are directly connected to each of hot and cold water lines. The safety valves are open due to the vacuum in the throat 30 generated by the water flow in the Venturi tubes 10 and/or 20, correspondingly. The flow of product then is mixing with the incoming water flow in the Venturi tubes, and exiting the dosing device via the outgoing water hoses 12 and 14. The resulting water/laundry care mix is carried into the washing machine via hoses 12 and/or 14. An O-ring 39 is seated on the outside of the conduit 35 to ensure a better seal between the spout 38 and the conduit 35.

According to the preferred embodiment of the invention, the ratio of the diameter of the end of the Venturi tube ( $d_1$ ) to the diameter of the throat of the Venturi tube ( $d_2$ ) is greater than 1.65, most preferably greater than 2.5, in order to attain the required vacuum for dosing the products. If the internal diameter of water hoses is less than the diameter of the end of the Venturi tube ( $d_1$ ), then the preferred ratio should be based on the ratio of the internal diameter of water hose to the diameter of the throat of the Venturi tube ( $d_2$ ).

Figures 6, 7, and 8 illustrate yet other embodiments of the inventive devices 100 and 110 wherein a single water supply and a single Venturi tube are employed. The Venturi tube 11 in Figure 6 or 15 in Figure 7 is connected to the incoming water supply hose 3 and the outgoing water supply hose 13 via couplings 16 and 22. The mechanism of dosing action is the same as described above for Figures 3, 4, and 5, except that

when a single Venturi tube 11 or 15 is employed, it connects directly through the conduit 47 to the laundry care container 40 (contrasted to a series of conduits 33, 34, and 35 in Figure 4 for a double Venturi tube device).

5

Figure 6 illustrates a single Venturi tube/single laundry care container embodiment of the inventive device 100, while Figure 7 illustrates a single Venturi tube/three laundry care containers embodiment of the device 110. The Venturi tube 11 in Figure 6 connects to a single laundry care container via a single conduit 47. The Venturi tube 15 in Figure 7 connects to three laundry containers directly via conduits 47, 48, and 49.

Figure 8 illustrates the example of the safety assembly for the single Venturi tube embodiment of the device, operating as described above with reference to Figure 4.

Figure 9 illustrates an alternative embodiment of the invention. The inventive device 120 operates substantially the same as described above in connection with Figures 3-5, except that a pump 210 is employed in place of a Venturi mechanism. The device with pump is highly preferred for washing machines which are placed at a low water pressure locations. Otherwise, according to the present invention, the Venturi mechanism is preferred, since it has no moving parts, as in the pump. In addition, the Venturi-based device does not require an external power supply, only a battery to run the electronic circuit to control the solenoid valves. The pump-based device in Figure 9 employs simple tubes 230 in place of the Venturi tubes.

Similarly to the Venturi-based inventive devices, it may include single or dual water supply, either one in combination with a variety of dosing containers.

In the preferred embodiment of the invention, laundry care containers visibly protrude above the top surface of the device, and most preferably, the containers are transparent, so that the user may monitor the level of the remaining detergent, and refill or replace the containers at an appropriate time.

Figures 10A, 10B, 11A and 11B are examples of the logic flow diagrams for the machine-generic algorithm for programming the processing unit. It can be seen that the algorithm for the operation of the inventive device distinguishes between the major water addition and the water pulse, depending on the duration of the water flow. Thus, if the water flow is on for longer than about 5 to 30 seconds, preferably longer than 15, more preferably longer than 10 seconds, then the algorithm processes this information as a major water addition and sends the signal to open the corresponding solenoid valves or pumps to cause the dosing of the correct laundry care composition. The machine-generic algorithm also contains instructions for resetting itself and for distinguishing whether the water addition is the initial water addition in the laundry cycle or the successive water addition, resulting in the instructions sent for solenoid valve or pump leading to the second laundry care composition to open if chosen so by the user. The machine-generic algorithm may contain various options which would be selected by the user on the display panel of the device, which selections would send instructions to the algorithm within the processing unit of the device. Thus, Figures 11A and 11B illustrate a more complicated algorithm for the laundry cycle with the pre-wash option. The display panel may contain various buttons to allow the user to manipulate the algorithm: e.g., pre-wash, bleach, booster, fabric softener, reset buttons, type of wash, wash load, etc. The algorithm and

the processing unit may also include the detection and the display of the low power of battery or malfunction. The processing unit may contain a ROM chip. The algorithm in the electronic circuit is then upgradable via switching to a new ROM chip containing a new algorithm or via flashing the ROM with a new algorithm.

#### Sensor

The sensor senses the flow of water converting a flow signal therefrom into an electronic impulse, and sending the signal that the water flow is on to the processing unit inside the control unit. The preferred sensor is selected from a pressure transducer or a flow or motion sensing devices, or combinations thereof.

15

The sensor can be placed at a water supply feed, whether the incoming or outgoing feed from the device. The sensor combined with the algorithm may additionally detect other parameters, e.g. water inflow pattern, total water consumed for each cycle. By the use of the sensors, signals can be obtained (and combined with one another) which monitor the wash cycle and the cycle time and provide a trigger for the inventive dispensing device. Other suitable sensors include but are not limited to devices sensing electrical current, sound, temperature, vibration, etc.

#### Laundry Care Containers

Generally, any laundry care container may be used as long as its spout fits snugly into the conduit leading to the Venturi tube. In the preferred embodiment of the invention, however, special cartridges, most preferably removable and replaceable, are employed.

In a preferred embodiment of the invention, to prevent user mistakes in inserting wrong containers into the slot, the slots and/or containers are clearly labeled and may have an encoded set of information about the container's contents and its use instructions affixed to it, the device further comprising means for retrieving and, optionally, storing said information, and means for executing instructions either received directly from the retrieved information or from the stored information. The instructions may be in the form of a bar code, a magnetic strip, a microchip or any other suitable machine-readable attachment. In another embodiment of the invention, the shape of the containers and the corresponding interlocking slots are shaped differently to prevent misplaced installation of products. Another way of preventing misplaced installation is via color or shape or size differentiation with common interlocks.

In a preferred embodiment, the bottom of the container (containing the spout) is bevelled to enhance the draining of the composition.

#### Laundry Care Compositions

Any laundry care compositions are suitable for use with the inventive device. The particular advantage of the inventive device is that it pre-mixes the laundry care composition with water, thus diluting the laundry care composition prior to its introduction into the washing machine. Thus, in a particularly preferred embodiment of the invention the laundry care composition is a concentrate. For a laundry detergent composition, it generally means that the composition comprises at least 20%, by weight of the composition, preferably from 40 to 100%, most preferably from 60 to 100% of a surfactant. Generally, concentrate compositions contain little if any

water, generally from 0 to 50%, preferably less than 20%, most preferably less than 10%.

Another particularly preferred composition for use with the  
5 inventive device is a bleach composition; by virtue of pre-dilution associated with the use of the inventive device such composition may be introduced into the washing machine, without causing the pinpoint damage to the fabrics. The most preferred bleach is a peracid, such as imidoperacid, diperoxydodecanoic  
10 acid (DPDA), perlauric acid, perbenzoic and alkylperbenzoic acids. Especially preferred peracid is phthalimido-percaproic acid (PAP). In another embodiment, the inventive device may dose sodium hypochlorite solution, which is generally referred to as chlorine beach. The concentration of hypochlorite  
15 solution is in the range between 1.5 % to 10%, preferably between 3 to 7%.

In another embodiment, the inventive device may sequentially dose bleach precursors and peroxygen bleach sources. The  
20 nonanoyloxybenzene sulfonate (NOBS) and tetraacetyl ethylene diamine (TAED) are typical bleach precursors. Other classes of bleach precursors comprise acylated citrate ester, benzoxazin-type and amido derived precursors. Suitable peroxygen bleach  
bleach sources to be used herein are hydrogen peroxide,  
25 percarbonates, persilicates, perborates, peroxyacids, hydroperoxides, and diacyl peroxide. As used herein a peroxygen bleach source refers to any compound, which produces perhydroxyl ions when said compound is in contact with water.

The reference in this specification to any prior publication  
(or information derived from it), or to any matter which is  
known, is not, and should not be taken as an acknowledgment  
or admission or any form of suggestion that that prior  
5 publication (or information derived from it) or known matter  
forms part of the common general knowledge in the field of  
endeavour to which this specification relates.

Throughout this specification and the claims which follow,  
10 unless the context requires otherwise, the word "comprise",  
and variations such as "comprises" or "comprising", will be  
understood to imply the inclusion of a stated integer or  
step or group of integers or steps but not the exclusion of  
any other integer or step or group of integers or steps.

The claims defining the invention are as follows:

1. A non-intrusive device for automatically dosing at least one liquid laundry care composition to an automatic laundry washing machine, the device located along water supply feed to the washing machine with an incoming water supply feed to the device and outgoing water supply feed out of the device, the device comprising:
- 10 - a Venturi tube, the both ends of the tube protruding externally to the housing of the device for connections to the incoming and the outgoing water supply feed,
  - a dosing container for holding the laundry care composition, the throat of the Venturi tube connected by a conduit to the dosing container;
  - a sensor for determining water flow through the incoming water supply feed, the sensor located at the incoming water supply feed and connected to
  - 20 - an electronic circuit containing a clock and a processing unit programmed with a machine-generic algorithm to control
  - a solenoid valve, coupled to the same circuit and located within the conduit connecting the Venturi tube and the dosing container, the valve opening or closing the flow of the laundry care composition from the dosing container,
  - 25
- wherein the algorithm is capable of determining the actual cycle at any duration of wash for various cycle designs from various washing machines, without the
- 30 input of precise cycle design; and dose the correct products.

2. The device of claim 1 comprising at least two dosing containers, one for holding a laundry detergent and the other for holding a fabric softener.  
5
3. The device of claim 1 connected to two water supply feeds: hot water and cold water.
4. The device of claim 3 comprising two Venturi tubes, one  
10 connected to the hot water supply feed; the other connected to the cold water supply feed.
5. The device of claim 4, wherein the throats of the two Venturi tubes are connected to each other by a  
15 connecting conduit, the connecting conduit being in turn connected to the conduit to the dosing container.
6. The device of claim 1, wherein the sensor is selected from a pressure transducer and a flow sensor.  
20
7. The device of claim 1 wherein the processing unit comprises a clock.
8. The device of claim 1 wherein the algorithm resets the  
25 clock at the end of the total laundry cycle.
9. The device of claim 1 wherein the algorithm differentiates between various wash cycles based on the number of major water additions.  
30
10. The device of claim 1 wherein the algorithm differentiates between a water pulse and a major water

addition.

- 5 11. The device of claim 1 wherein the algorithm comprises the instructions to open the solenoid valve which is connected to the Venturi tube which has water flow through it on for longer than about 5 to 30 seconds.
- 10 12. The device of claim 1 wherein the algorithm comprises instructions to close the solenoid valve if water flow is off.
- 15 13. The device of claim 1 wherein the device comprises two dosing containers: a dosing container for a laundry detergent and for a laundry softener and wherein the algorithm comprises the instructions to open the solenoid valve to the laundry softener dosing container at the point of the second major water addition.
- 20 14. The device of claim 1 wherein the device further comprises a safety check assembly located in the conduit connecting the Venturi tube and the dosing container, to prevent water flow into the dosing container.
- 25 15. The device of claim 1 wherein the Venturi tube is connected to two or more dosing containers, to each through a separate opening in its throat connected to a separate conduit to each dosing container.
- 30 16. The device of claim 1 further comprising a control panel comprising a selection for reset and for pre-wash.

- 5 17. The device of claim 1 wherein the ratio of the internal diameter of the end of the Venturi tube to the internal diameter of the throat of the Venturi tube is greater than 1.65.
- 10 18. The device of claim 1 wherein the ratio of the internal diameter of a water supply feed hose to the internal diameter of the throat of the Venturi tube is greater than 1.65.
19. The device of claim 1 wherein the dosing container is removable.
- 15 20. The device of claim 1 wherein the laundry care composition is a concentrated composition.
- 20 21. The device of claim 1 wherein the laundry care composition comprises a peracid or chlorine bleach.
- 25 22. The device of claim 1 wherein the algorithm in the electronic circuit is upgradable via switching a new ROM chip containing a new algorithm or via flashing the ROM with a new algorithm.
- 30 23. A non-intrusive device for automatically dosing at least one liquid laundry care composition to an automatic laundry washing machine, the device located along water supply feed to the washing machine with an incoming water supply feed to the device and outgoing water supply feed out of the device, the device comprising:

- a water conduit tube, the both ends of the tube protruding externally to the device for connections to the incoming and outgoing water supply feed;
  - 5 - a dosing container for holding the laundry care composition, the container connected by a conduit to the water conduit tube,
  - a sensor for determining water flow through the incoming water supply feed, the sensor located at  
10 the incoming water supply feed and connected to
  - an electronic circuit containing a clock and a processing unit programmed with a machine-generic algorithm to control
  - a pump, coupled to the same circuit, the suction  
15 end of the pump connected by a conduit to the dosing container and the discharge end of the pump connected to the water supply feed,
- wherein the algorithm is capable of determining the actual cycle at any duration of wash for various cycle  
20 designs from various washing machines, without the input of precise cycle design; and dose the correct products correctly.

24. A non intrusive device for automatically dosing at  
25 least one liquid laundry care composition to an automatic laundry washing machine substantially as hereinbefore described with reference to the accompanying figures.

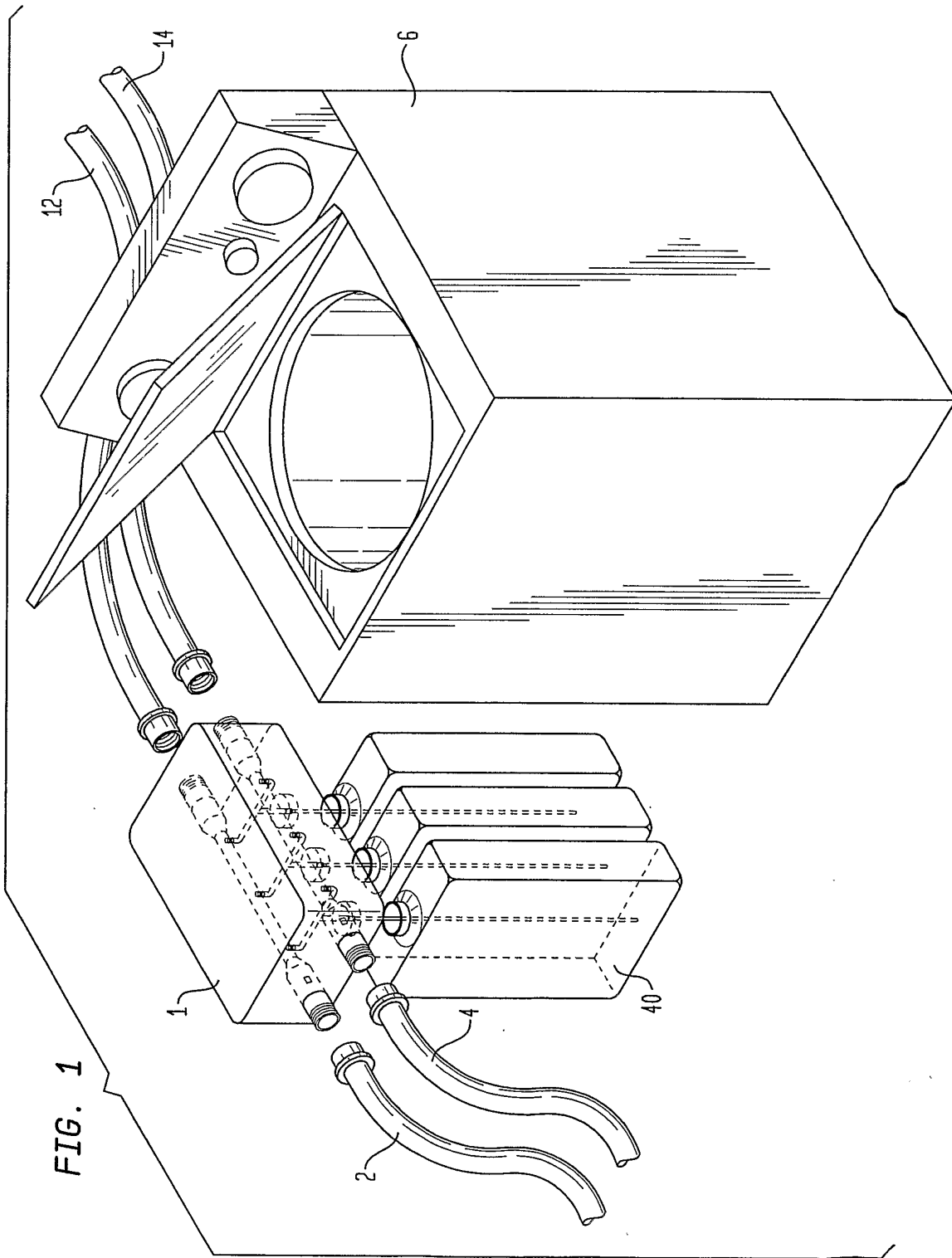
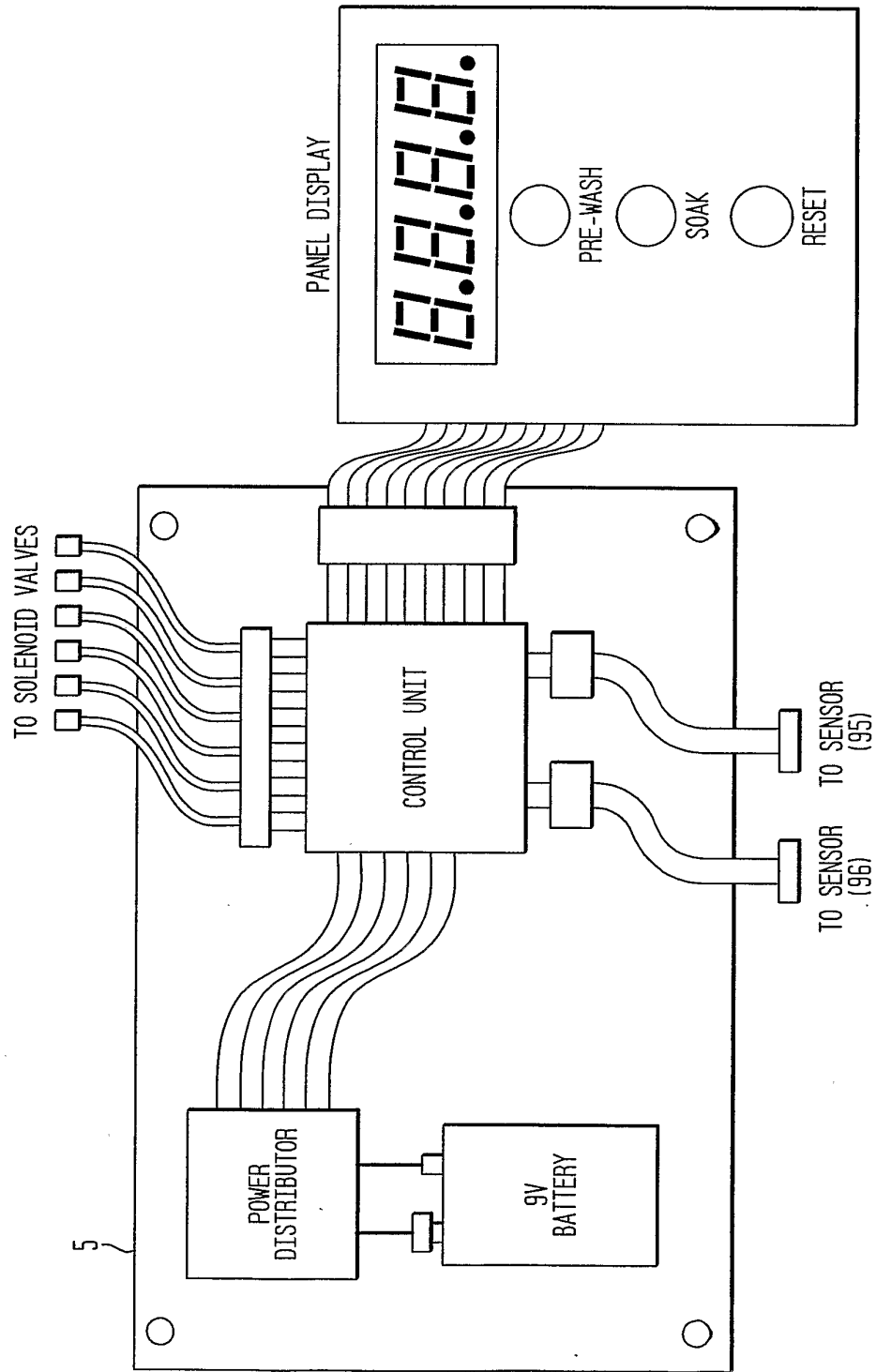
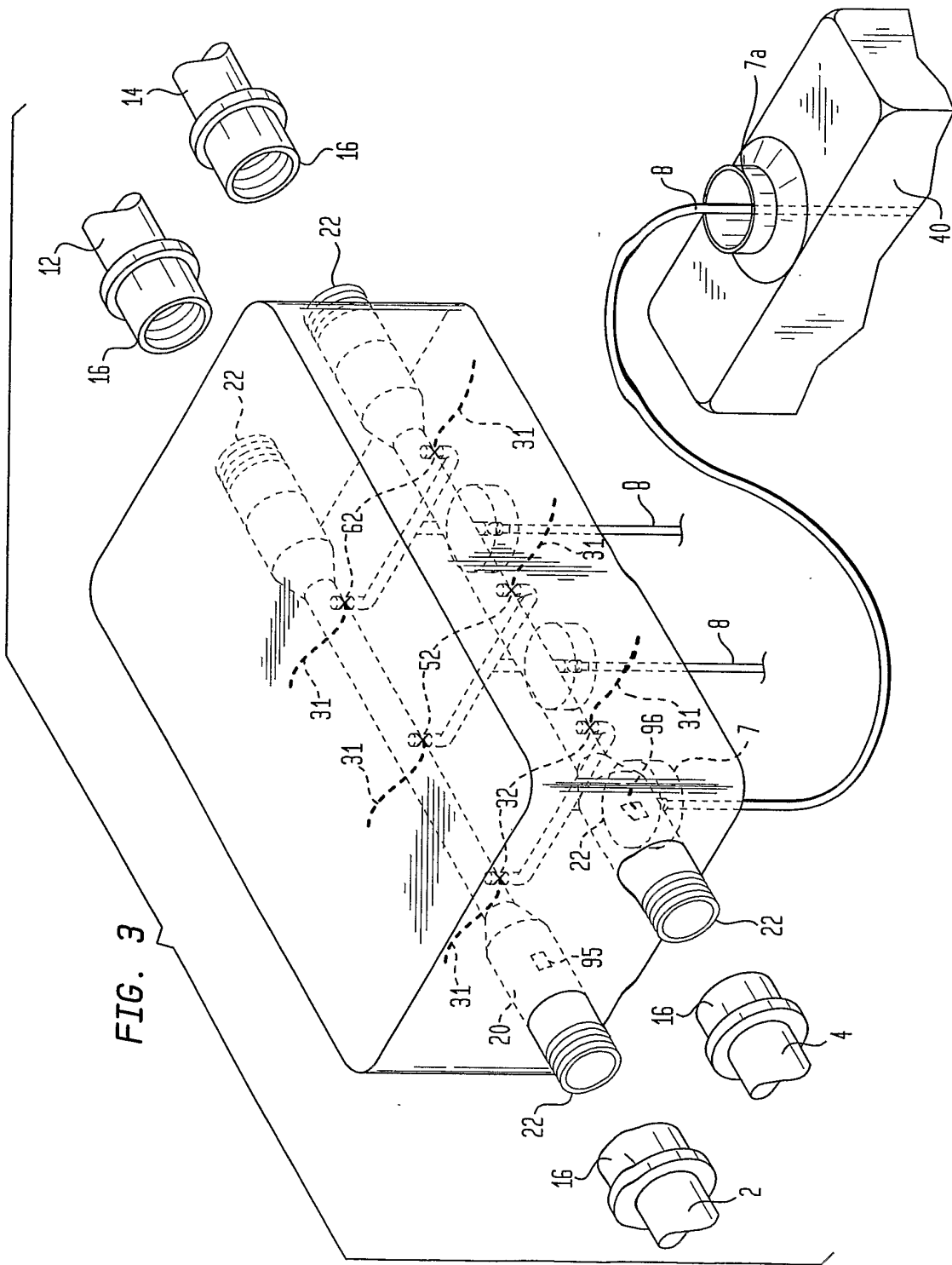

FIG. 2





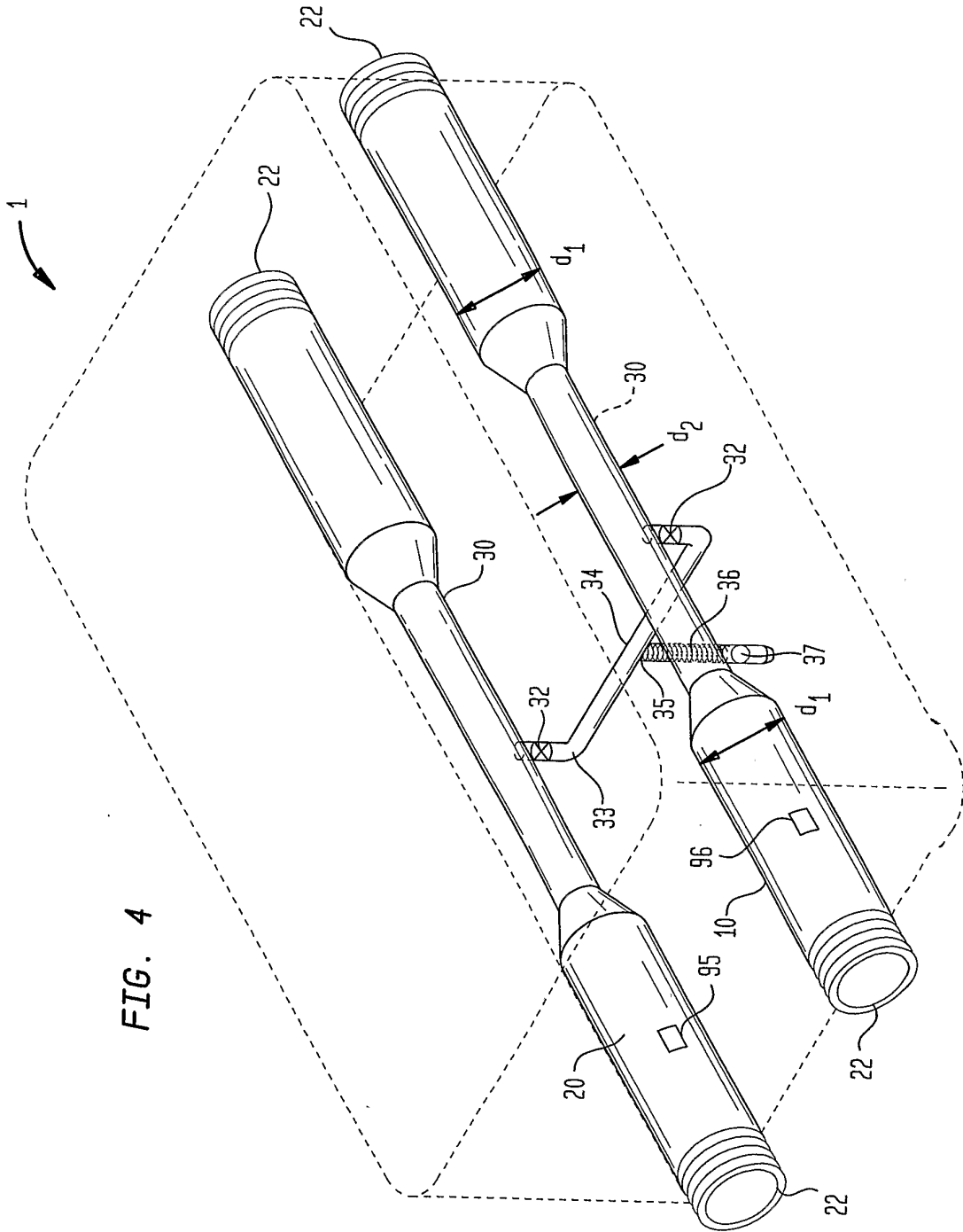

FIG. 4

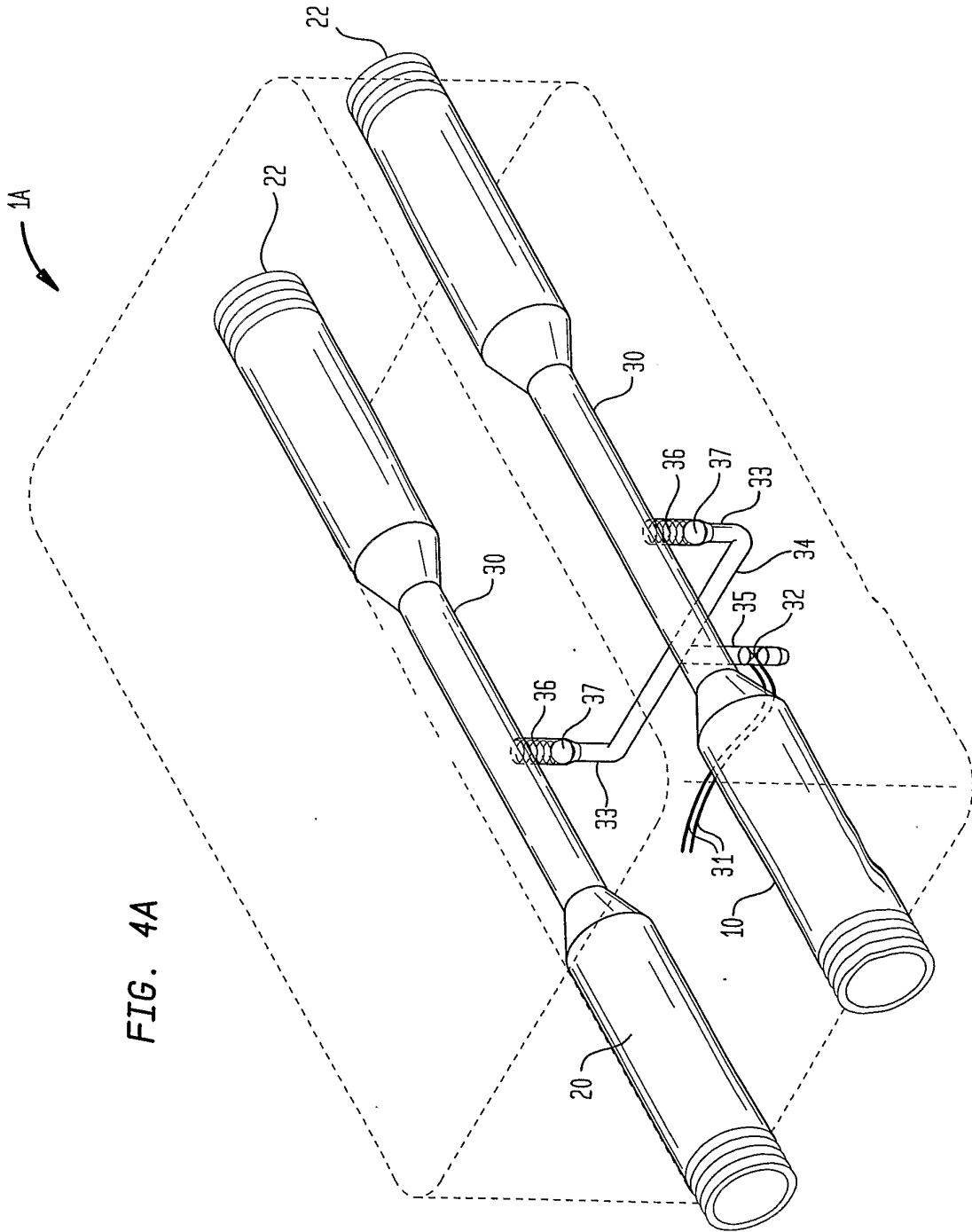

FIG. 4A

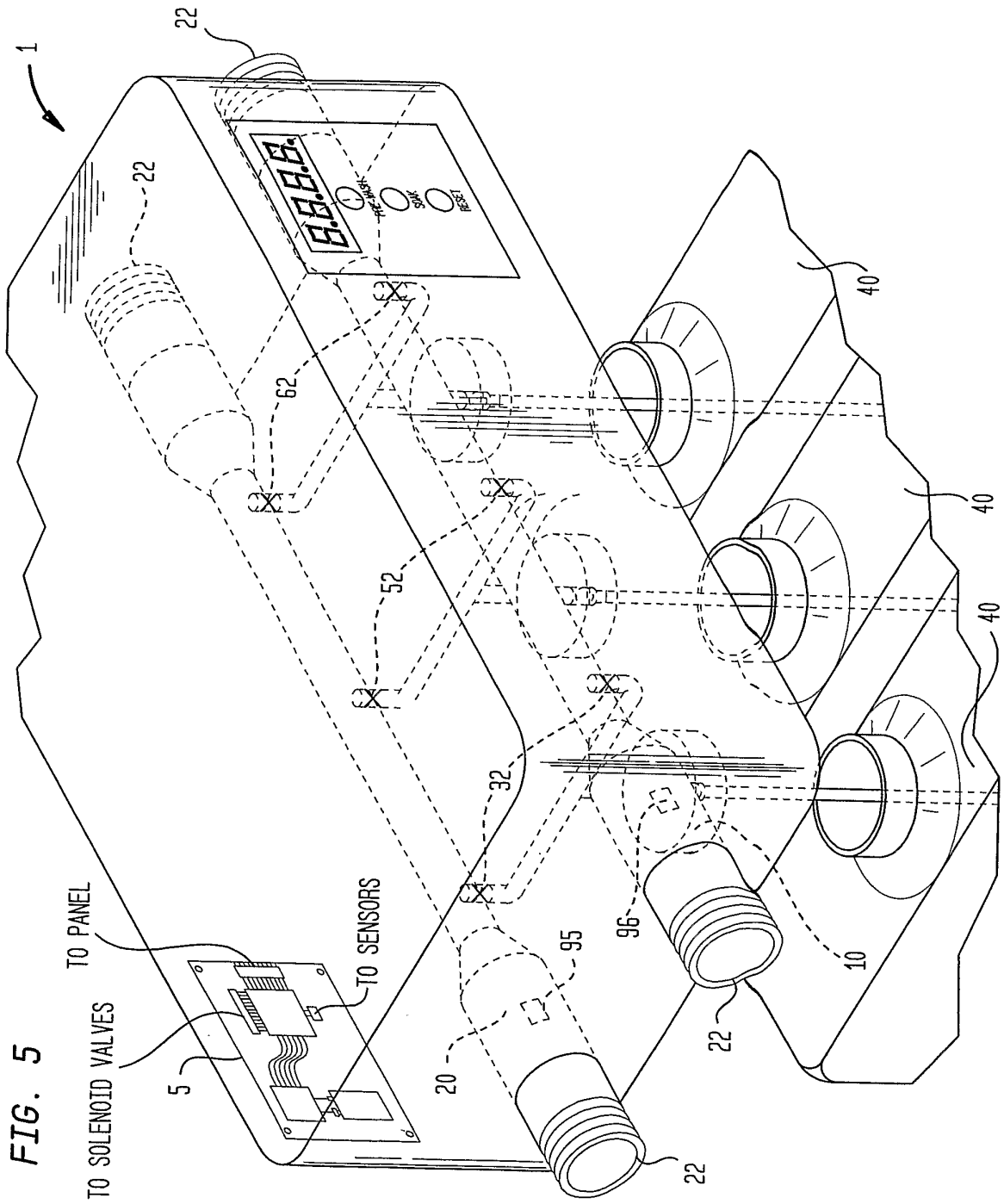
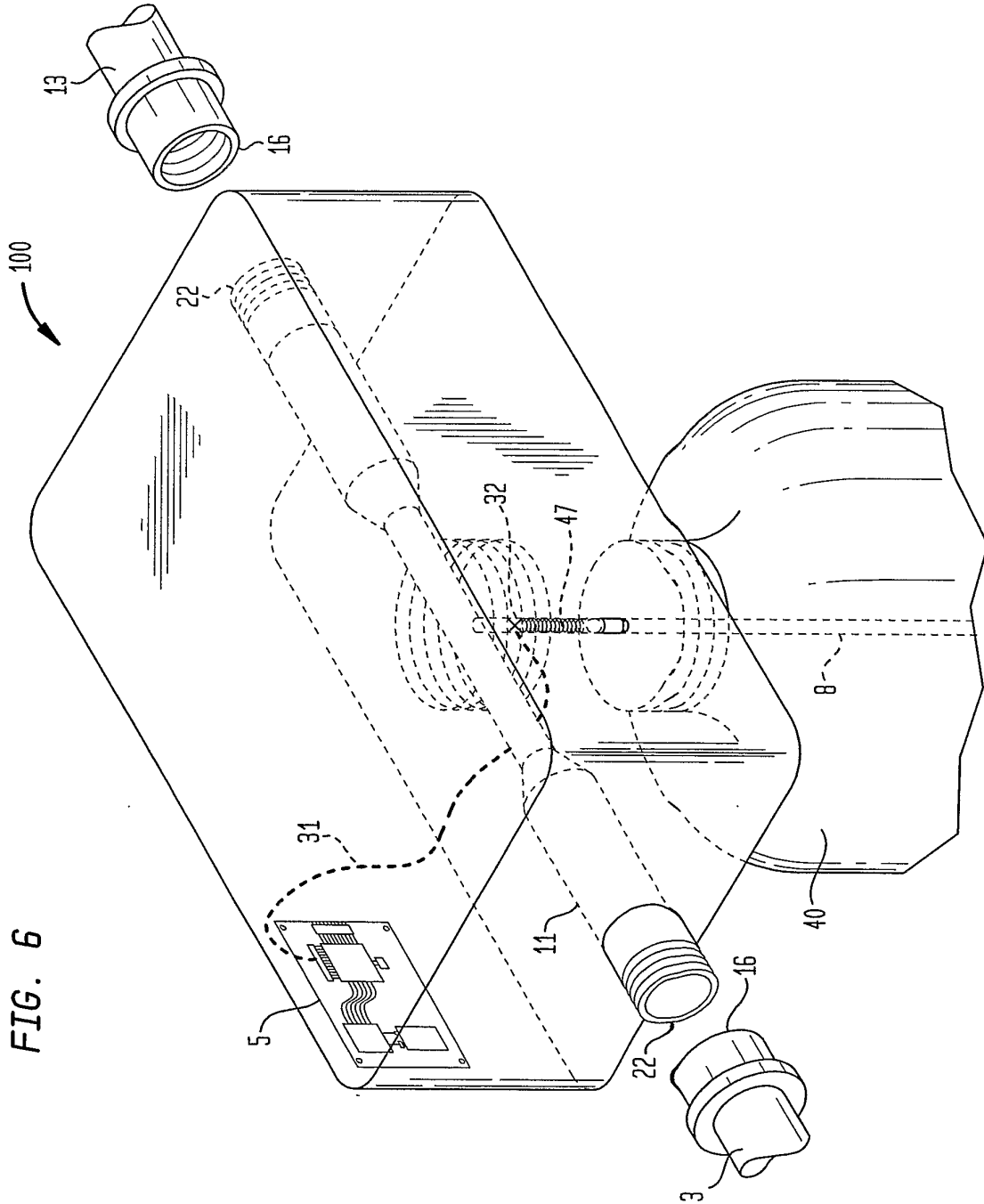

FIG. 5

TO SOLENOID VALVES

TO SENSORS



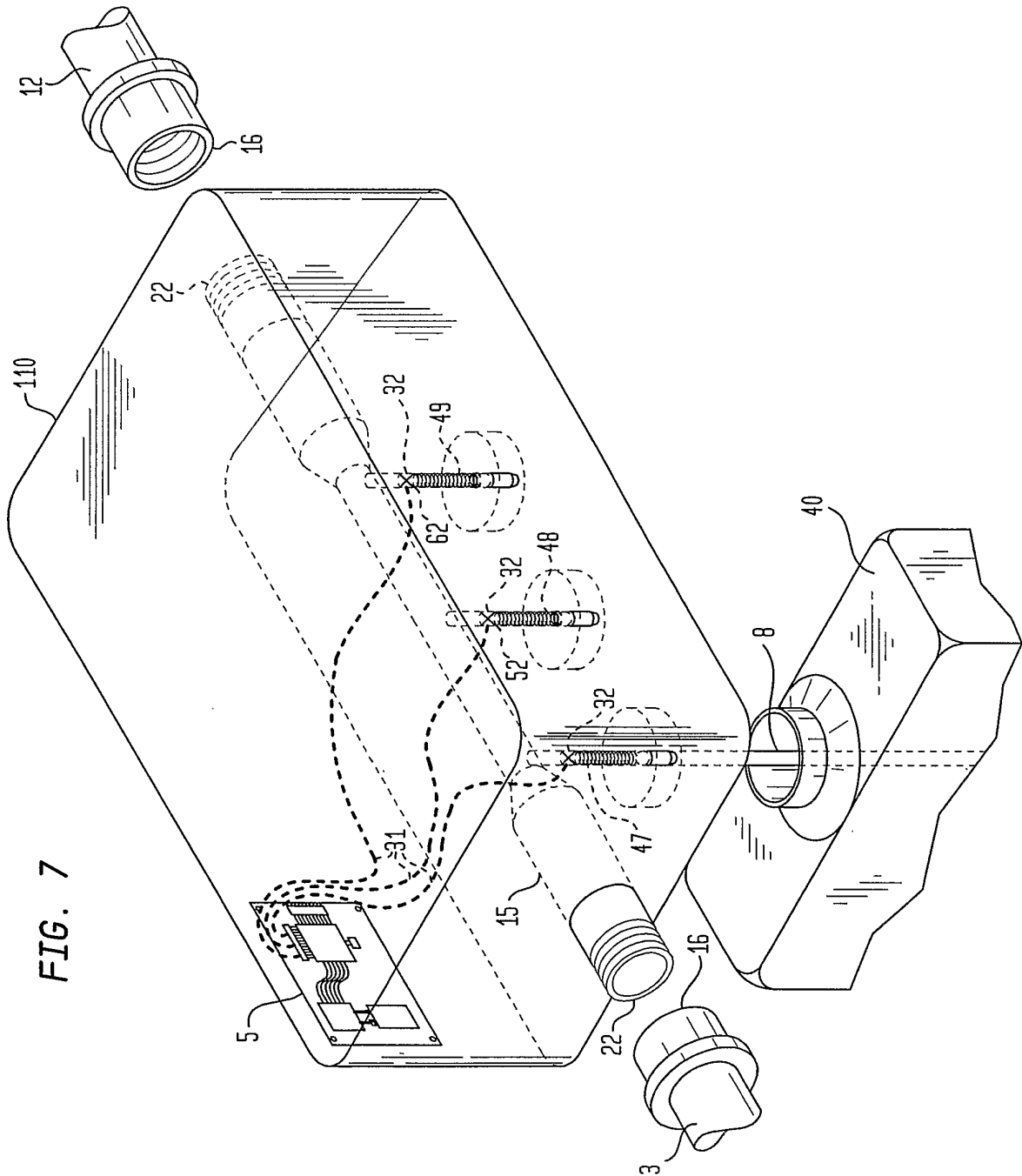

FIG. 7

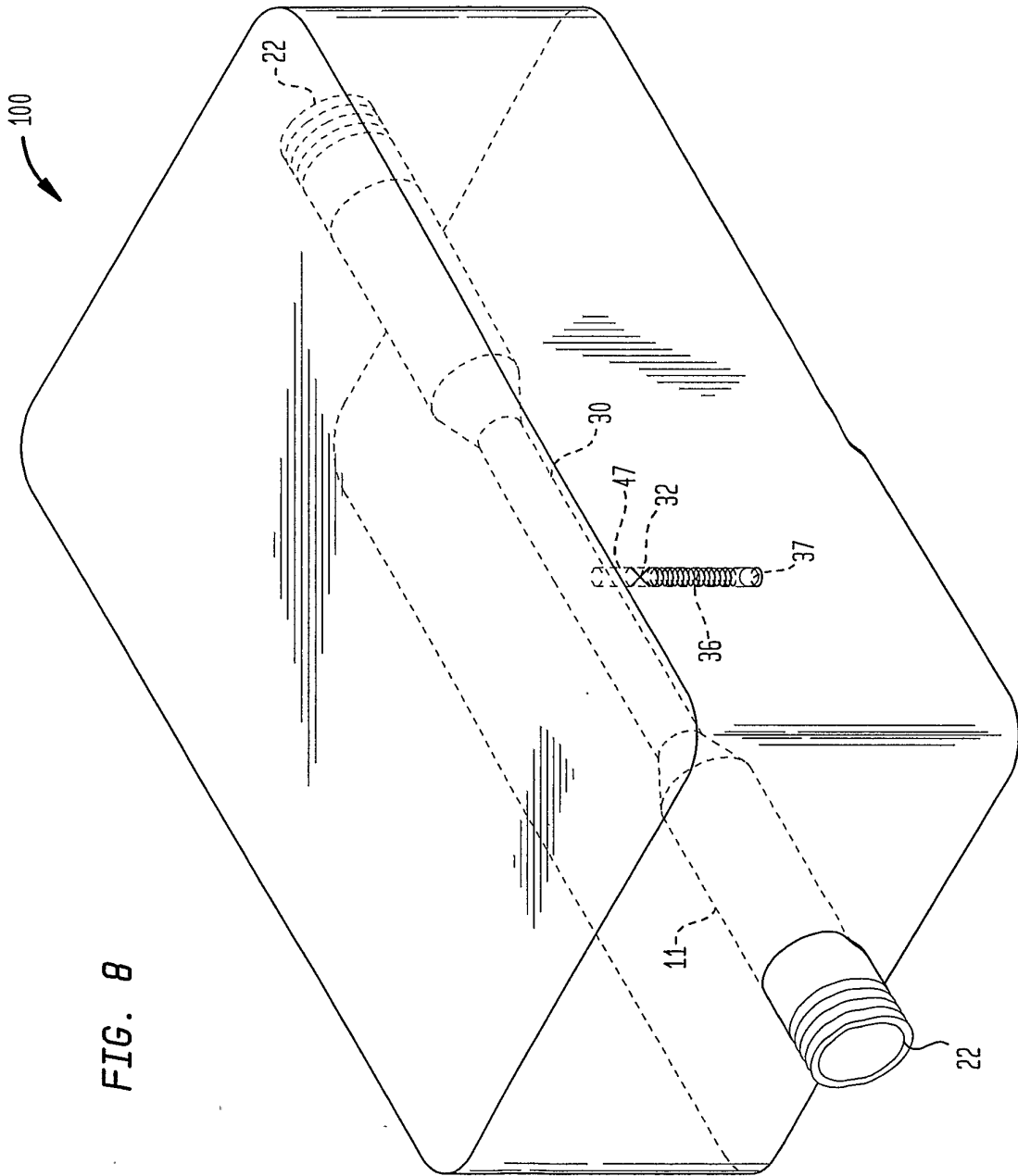

FIG. 8

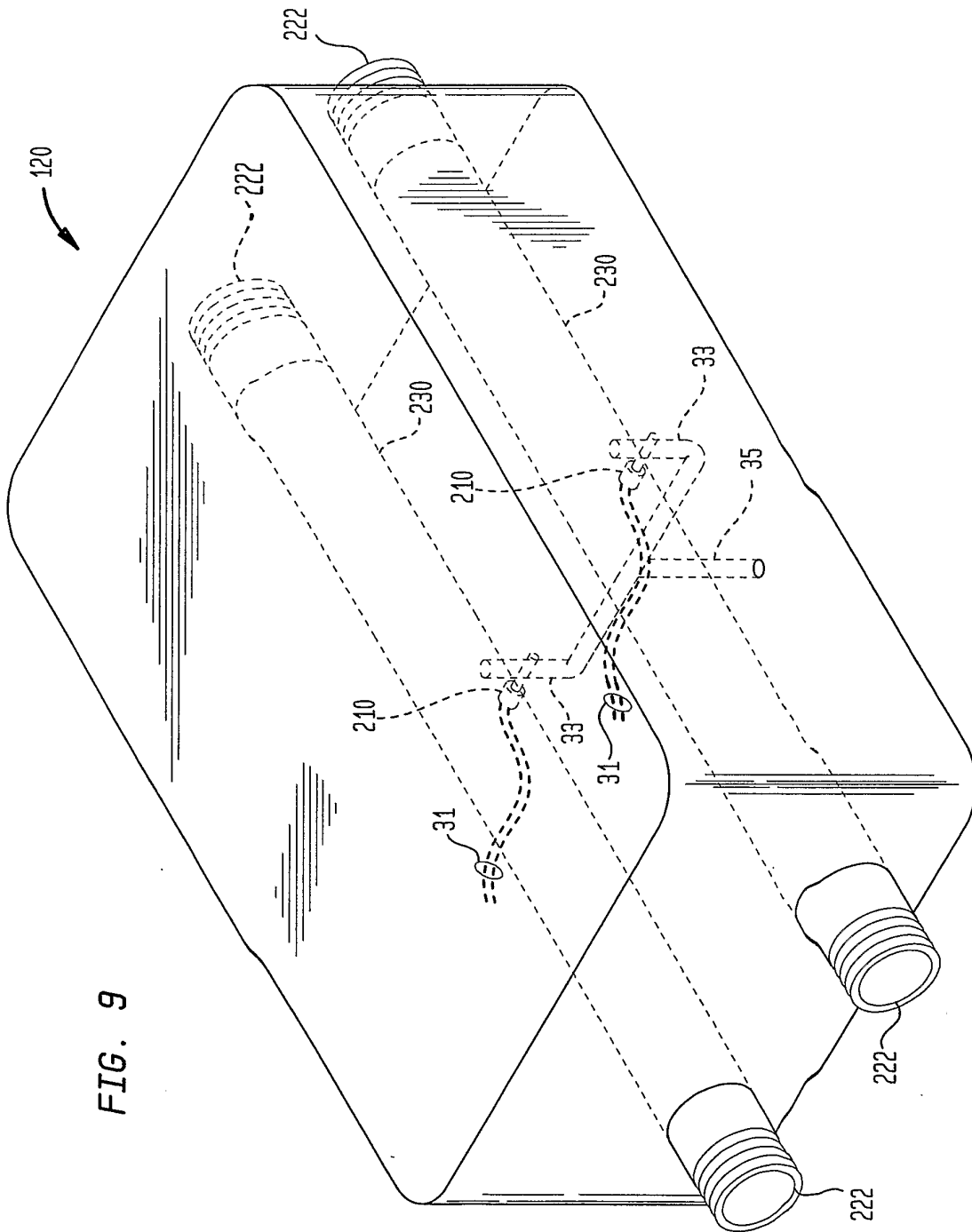
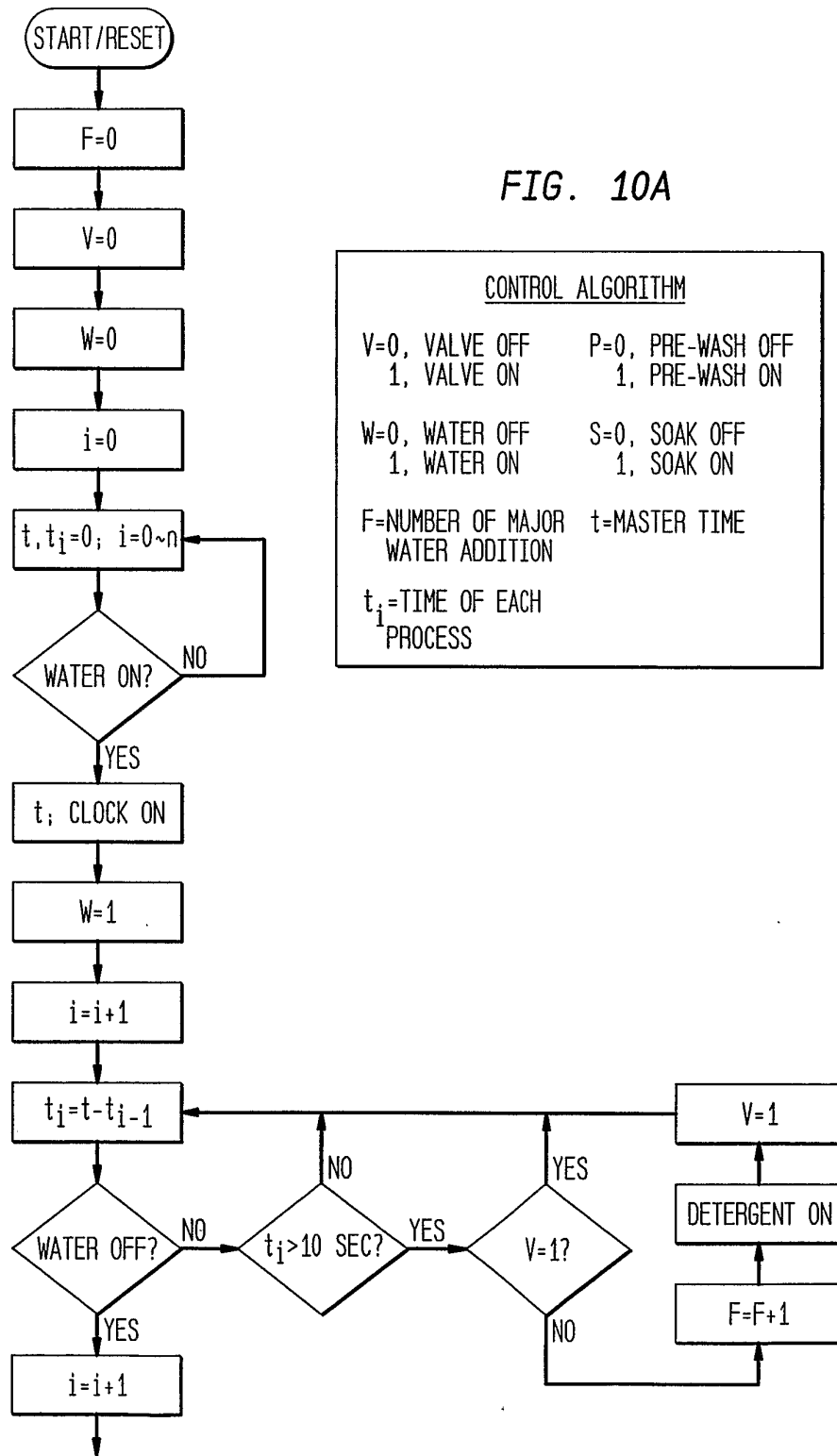

FIG. 9

FIG. 10A



12/14

FIG. 10B

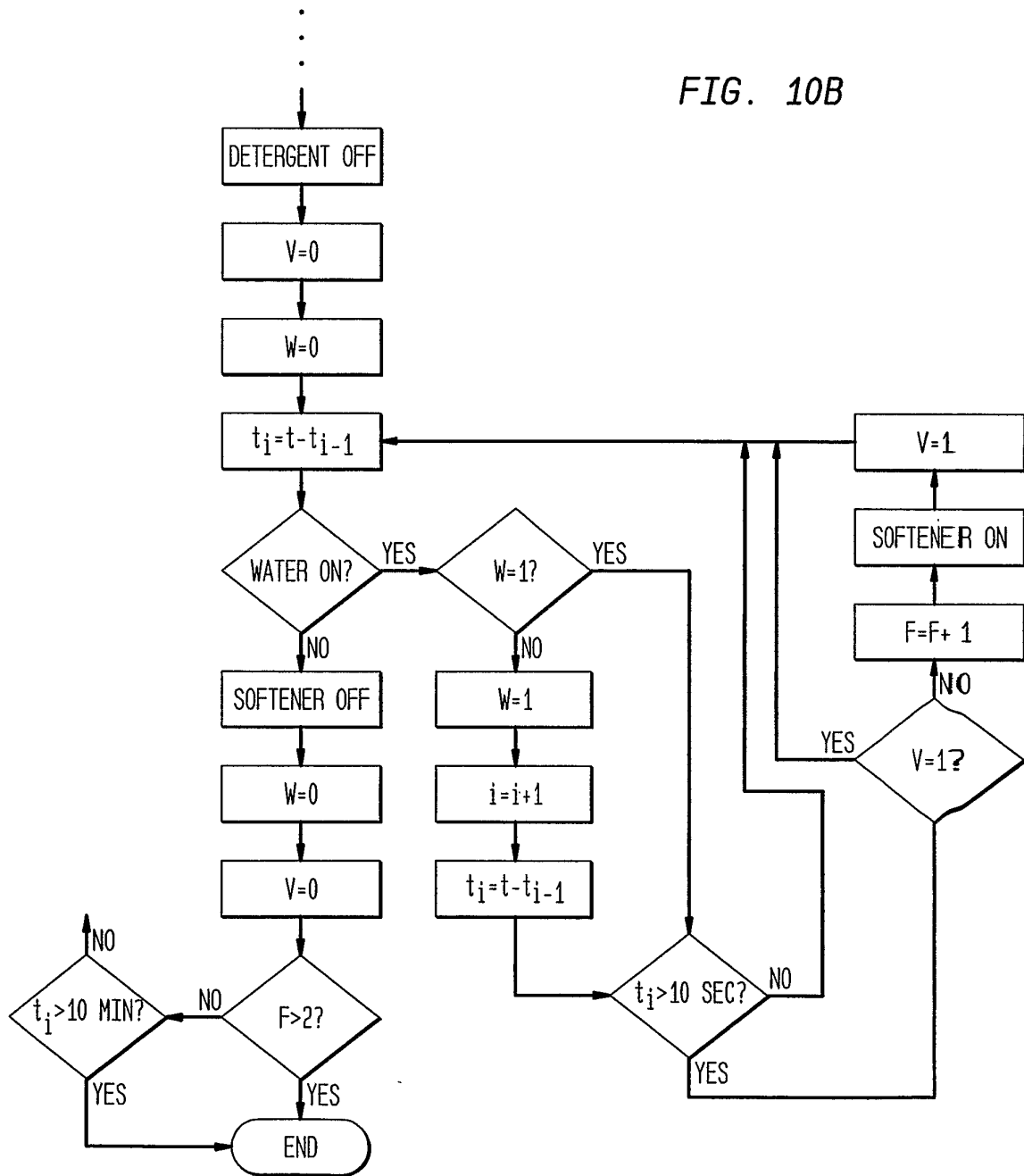

13/14  
FIG. 11A

