



(12) **EUROPEAN PATENT APPLICATION**

(43) Date of publication:
18.09.2013 Bulletin 2013/38

(51) Int Cl.:
F21V 7/00 ^(2006.01) **F21V 7/10** ^(2006.01)
F21V 7/22 ^(2006.01) **F21V 17/00** ^(2006.01)
F21W 131/105 ^(2006.01) **F21W 131/107** ^(2006.01)

(21) Application number: **12290085.5**

(22) Date of filing: **12.03.2012**

(84) Designated Contracting States:
AL AT BE BG CH CY CZ DE DK EE ES FI FR GB GR HR HU IE IS IT LI LT LU LV MC MK MT NL NO PL PT RO RS SE SI SK SM TR
 Designated Extension States:
BA ME

- **Rocard, Florian**
95800 Cergy Le Haut (FR)
- **Boinet, Loic**
76240 Le Mesnil Esnard (FR)

(71) Applicant: **Thorn Europhane S.A.**
27705 Les Andelys Cedex (FR)

(74) Representative: **Thun, Clemens**
Mitscherlich & Partner
Patent- und Rechtsanwälte
Sonnenstrasse 33
Postfach 33 06 09
80331 München (DE)

(72) Inventors:
 • **Rami, Jean-Paul**
27200 Vernon (FR)

(54) **Reflector assembly for use in a luminaire**

(57) A reflector assembly (1) for use in a luminaire (110) in particular for floodlight, sport and area lighting applications forms a dome shaped structure for accommodating at least one light source (100) therein and emitting the light of said light source (100) via an opening of

said dome shaped structure. Said reflector comprises a plurality of reflector segments (2-5) which are arranged to form together the dome shaped structure wherein at least two of said reflector segments (2-5) have different reflection characteristics.

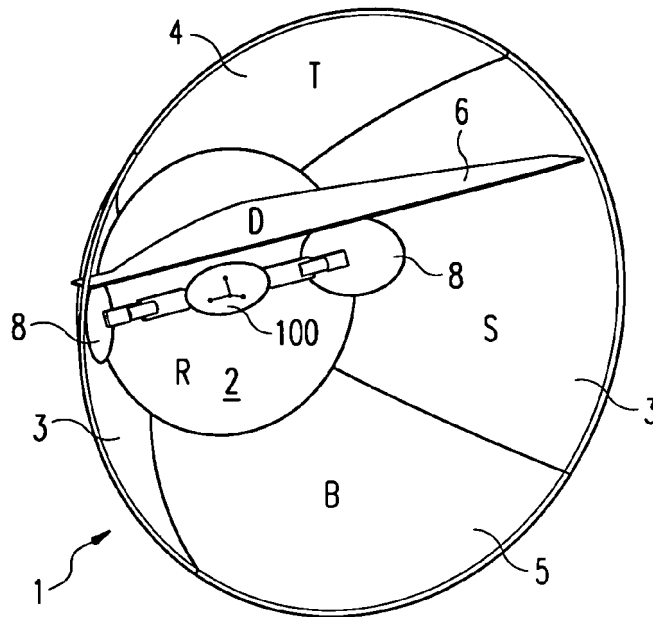

Fig. 1

Description

5 [0001] The present invention relates to a reflector assembly for use in a luminaire provided to brightly illuminate a target area wherein said luminaire can be used for floodlight, sport and area lighting applications. Further, the present invention is directed to a method for adapting the light emitting characteristics of a reflector assembly.

10 [0002] Lighting devices with incandescent or arc discharge lamps are routinely used to illuminate the exterior areas of commercial businesses for purposes of enhancing the appearance of the business at night and for promoting interest in the goods and services of the business by actual and potential customers. Restaurants and shopping malls represent just a few of the business types for which exterior luminaires play an important role in marketing and facilitating product sales. However, also other facilities such as parking areas, outdoor sports stadiums or indoor arenas usually require intensive illumination of specific areas, e.g. in order to provide lighting that allows a sport to take place safely and provide good viewing conditions, both in visibility of the sports action and comfort of the audience.

15 [0003] For lighting applications as mentioned above, reflectors are commonly used to reflect light emitted from at least one light source. The reflectors have a dome shaped configuration and focus the reflected light in desired patterns and with desired levels of intensity so that energy costs are minimized while maximum lighting is achieved. Reflectors also serve to protect the light source, with some reflectors providing a protective enclosure to protect the light source from weather, dust, moisture, and the like.

20 [0004] In particular in floodlighting systems used for applications as mentioned above, a reflector is usually the only - or at least the most relevant - optical element of a luminaire which is available for shaping the light emitted into a desired pattern. Since depending on the application a luminaire is used for often a very specific light distribution with respect to the beam aperture and the peak intensity is desired, floodlighting systems are commonly offered with a large variety of reflectors which then are specifically selected to meet the requirements of the application.

25 [0005] Obviously, producing and storing a high number of different types of reflectors is not desirable. Due to their hollow, bulky shape, reflectors typically require specialized equipment for their manufacture, and take up considerable amounts of room after manufacture, making them expensive to manufacture, store and/or ship. Particularly in industrial-type reflectors or reflectors for floodlighting systems where the light sources and associated reflectors are often relatively large, shipping and storage becomes a major cost but also the equipment for manufacturing such reflectors like injections moulds or the like is expensive.

30 [0006] There is thus a need to provide a solution for facilitating the manufacture of a reflector which can be used in particular in a floodlighting system and provides a desired specific light emission characteristic.

[0007] In accordance with the present invention, the above object is solved by a reflector assembly as defined in independent claim 1 and by a method as defined in claim 9. Preferred embodiments and further developments of the present invention are subject matter of the dependent claims.

35 [0008] The inventive solution is based on the concept of using a reflector which includes multiple segments assembled to each other in order to finally form the reflective surface. By providing segments having different reflection characteristics, the emission of the luminaire can be easily and efficiently adapted to meet the lighting requirements of multiple applications. In particular, the "construction kit" solution proposed in accordance with the present invention allows manufacturing reflectors having different emission characteristics by simply selecting a specific combination of reflector segments with appropriate reflection characteristics. Even more, the resulting reflectors - though they emit light in different ways
40 - always have identical shapes and thus can be used with identical luminaire housings and/or supporting structures and preferably also with identical light sources. Accordingly, luminaires for floodlighting applications can be obtained with a wide variety of light emission characteristics and thus suitable for different applications at reasonable costs.

45 [0009] Thus, in accordance with the present invention a reflector assembly for use in a luminaire in particular for floodlight, sport and area lighting applications is provided wherein said reflector assembly forms a dome shaped structure for accommodating at least one light source therein and emitting the light of said light source via an opening of said dome shaped structure wherein said reflector comprises a plurality of reflector segments which are arranged to form together the dome shaped structure and wherein at least two of said reflector segments have different reflection characteristics.

50 [0010] Preferably, the reflector segments are adapted to form a continuously shaped reflective surface at the inner surface of the dome shaped structure. In particular, the reflector segments can have a shape and means to connect to a neighboring segment in such a way that a continuous and smooth transition between both segments is obtained. In this way, the resulting reflector assembly is almost identical to a one- piece reflector regarding the quality of the reflective surface but obviously can be manufactured in a much easier and more cost efficient way.

55 [0011] Further preferably, the reflector segments comprise one central reflector segment and at least two periphery reflector segments which extend from the central reflector segment to the light emitting opening of the dome shaped structure. The central reflector segment thus forms the basic element of the inventive reflector assembly and provides a reflective surface which is located behind the light source. In contrast to this, the periphery reflector segments form reflective surfaces at the sides and in front of the light source and are mainly responsible for shaping the emitted light

into the desired form. By selecting periphery reflector segments with specific reflection characteristics, the light distribution can be adapted in an extremely efficient way.

[0012] According to a preferred embodiment of the present invention, the periphery reflector segments substantially have an identical shape. This solution not only allows reducing the number of different parts to a minimum but also facilitates the assembly of the final reflector structure.

[0013] In a further preferred embodiment of the present invention, said reflector segments comprise one central reflector segment and four periphery reflector segments wherein in particular two opposed periphery reflector segments have identical reflection characteristics. In almost all applications of the inventive reflector assembly, it is desired that the light is emitted symmetrically to both sides of a luminaire. This characteristic can be obtained by providing two opposed periphery reflector segments which form lateral reflective surfaces and are identical with respect to their reflection characteristics. In contrast to this, the other periphery reflector segments form a top reflective surface and a bottom reflective surface and are individually selected to finally shape the emitted light beam. The reflection characteristics of these two further segments can differ from each other but also from the reflection characteristics of the two lateral segments.

[0014] Further preferably, said reflector segments are adapted to form at least one opening in the reflective surface for inserting or holding a light source. Similar to a classical one-piece reflector, the longitudinal light source is preferably located within the reflector such that it extends through a bottom portion of the dome structure. Two openings arranged in this bottom portion of the reflector allow the light source to extend with their ends to lamp holders which are provided in the surrounding area of the reflector. Alternatively, a holding structure for holding the light source can extend through the opening(s) in the interior of the reflector dome to safely hold the light source there.

[0015] In the following, the present invention and advantages thereof are explained in more detail with reference to the accompanying drawings.

Figures 1 to 3 show the inventive concept of a multi-part reflector assembly;

Figures 4 to 7 show different views of a periphery reflector segment used in the inventive reflector assembly;

Figures 8 and 9 show exploded views of the final reflector assembly;

Figures 10 and 11 show the inventive reflector in an assembled form;

Figure 12 shows as floodlighting luminaire comprising the inventive reflector assembly.

[0016] The inventive concept is at first explained with reference to Figures 1 to 3 which show different views of a rotational, dome shaped reflector assembly comprising five separate reflector segments - and one further optional reflector segment - which are assembled to the dome structure. In these Figures, only the light source and the reflector segments are shown but no further elements serving to connect the segments to each other. These further elements for finally forming the reflector are shown in the following figures and explained further below.

[0017] As mentioned above, the inventive concept is based on the idea of using a reflector which includes multiple segments assembled to each other in order to finally form the reflective surface. By using reflector segments with different optical characteristics, a wide range of lighting distributions for different floodlighting applications can be obtained.

[0018] In the embodiment shown in Figures 1 to 3, the reflector 1 consists of an assembly of five different parts or segments 2-5 made preferably in high reflective aluminum. In particular, the reflector 1 comprises a center portion formed by one central reflector segment 2 and a surrounding reflective surface extending from the center portion to the opening of the reflector 1 which is formed by four periphery reflector segments 3-5. In the assembled form, these reflector segments 2-5 provide a continuous concave shape similar to a conventional one-piece reflector. If required, a sixth reflector segment 6 can be added which extends through the interior of the dome structure and forms a deflector. This optional deflector segment 6 is for example used in case a strong asymmetric light distribution is desired.

[0019] In the preferred embodiment shown in the Figures, the four periphery reflector segments 3-5 have an almost identical shape wherein one reflector segment is shown in isolated form in Figures 4 to 7. It forms a quarter of the rotational dome structure and thus shows a rotational symmetry with respect to an axis I extending through the center of the reflector assembly perpendicular to the reflector opening (see Figure 2). In this way, the four periphery reflector segments 3-5 form in the finally assembled form a smooth and continuous reflective surface for distributing the light emitted by the light source 100 in a desired manner.

[0020] When it was explained above that the periphery reflector segments 3-5 have an almost identical shape, it should be clarified that this explanation refers to the general form of the reflective surface of the segments. As shown Figures 1 to 3, the reflector segments 3-5 can slightly differ from each other in the portion adjacent to the central reflector segment 2. In particular, preferably two of the periphery reflector segments are at their sides adjacent to the central segment 2.

provided with a recess 7 (see Figures 4 to 6) having approximately the form of a semi-circle. Together with corresponding recesses provided at the central reflector segment 2, they form two circular openings 8 which are arranged opposite to each other in the bottom region of the reflector dome and can be used to insert the light source 100 or allow that supporting elements extend from an exterior of the reflector 1 through the openings 8 in the interior of the reflector 1 for holding the light source 100 there. Preferably, these semi-circular recesses 7 are cut into the reflector segments after their production requiring only one single die-cast form for manufacturing the periphery reflector segments.

[0021] Although the four periphery reflector segments have an - almost - identical shape, they are usually made from different materials and thus have different optical characteristics. By combining reflector segments of different materials, the light distribution and intensity finally obtained can be adapted in order to meet the requirements of a floodlighting application.

[0022] The effect of changing the reflector material for the different segments can be seen from the following Table which shows the peak intensity (in cd/klm) at a target area and the resulting beam shape for different material combinations. In all examples, an identical light source was used:

material → resulting beam ↓	Anodized 87%	Miro4 Extra Bright	Miro7 Matt	Miro9 Hammered	Miro20 Bright Diffuse
Intensive 25000 cd/klm	R	S/T/B/D			
Semi-Intensive 18000 cd/klm	R	D	S/T/B		
Semi-Extensive 11600 cd/klm	R	D	T/B		S
Extensive 8000 cd/klm	R	D			S/T/B
Elliptical 5500 cd/klm	R	D		S/T/B	

[0023] The letters in the table above refer to the different reflector segments as follows:

- R: central reflector segment (2)
- S: side reflector segment (3)
- T: top reflector segment (4)
- B: bottom reflector segment (5)
- D: deflector reflector segment (6)

[0024] The results summarized in this table clearly show that the selection of the material for the different reflector segments has a significant influence on the resulting light distribution. It is thus indeed possible to adapt the characteristics of a reflector by specifically combining different materials although the shape of the reflector segments is always identical. Even more, not only the shape of the reflector segments does not change but also the resulting shape of the finally assembled reflector is always the same. Accordingly, all further elements of the luminaire, in particular the means for connecting the reflector segments to each other and also a holding structure for holding the reflector within a luminaire are generally the same and can be used in all cases independent from the actual reflector characteristics. Floodlighting luminaires having very different characteristics can thus be obtained in a cost efficient way on the basis of the present invention.

[0025] Whereas the figures so far only showed the general concept of combining the reflector elements to the final reflector dome, Figures 8 to 11 show in more detail how the segments are connected to each other.

[0026] In particular, the exploded views of Figures 8 and 9 show that two adjacent periphery reflector segments 3-5 are interconnected by a connection element 10 which extends over the entire connection region at the outer surface of the two segments 3-5. The connection elements 10 ensure that the reflector segments 3-5 are secured in the adjacent position and that no gaps occur between two segments 3-5. In this way, the desired smooth and continuous reflective surface is obtained.

[0027] At the reflector opening, an end plate 12 is provided having in the shown example a quadratic outer shape and a circular opening corresponding to the opening of the dome formed by the peripheral reflector segments 3-5. This end plate 12 stabilizes the dome structure and is connected to the reflector segments 3-5 as well as to end portions of the connecting elements 10. In this regard, the peripheral reflector segments 3-5 preferably have flanged end portions 9

allowing to fix the reflector segments 3-5 to the end plate 12 by bolts or screws 13.

[0028] At the bottom portion of the reflector 1, the central reflector segment 2 is covered by a bottom cap 15 stabilizing this bottom area of the reflector 1 by slightly extending with a flanged end portion 16 over the end regions of the peripheral reflector segments 3-5. The flanged end portion 16 is also adapted for a connection with the four connecting elements 10 by using further bolts or screws 13 and comprises two lateral openings 17 aligned with the openings 8 in the reflector dome. The finally obtained reflector 1 is shown in the assembled form in Figures 10 and 11 and exhibits stability sufficient for its further use in floodlighting luminaires as well as an excellent optical reflective surface. It can be finally inserted in a casing or holding structure to form a floodlighting luminaire 110 as shown in Figure 12.

[0029] Several alternatives to the preferred embodiment shown in the figures are possible. In particular, the means for interconnecting the segments and stabilizing the reflector structure can of course be designed in an alternative way.

[0030] Further, the dome structure of the reflector could be formed by alternatively shaped reflector segments and it is in particular not necessary that four peripheral reflector segments are used which have an identical shape. It would for example also be possible to use only two peripheral reflector segments or to use even more segments which have different shapes but can again be assembled to the desired reflector shape.

[0031] Further, the resulting reflector structure could differ from the one shown in the figures and could for example be more similar to truncated pyramid or the like.

[0032] Obviously, the possibilities to adapt the optical characteristics of the resulting reflector are increased in case a higher number of reflector segments is used to form the reflector dome. On the other hand, assembling the segments to the final structure is then more complicate and care should be taken that no gaps occur which could significantly impair the optical characteristics of the reflector. In this regard, the shown embodiment provides a perfect compromise since the effort to manufacture the reflector is still low while the optical characteristics of the reflector can nevertheless be adapted in a relatively wide range.

Claims

1. Reflector assembly (1) for use in a luminaire (110) in particular for floodlight, sport and area lighting applications, said reflector assembly (1) forming a dome shaped structure for accommodating at least one light source (100) therein and emitting the light of said light source (100) via an opening of said dome shaped structure, **characterized in that** said reflector comprises a plurality of reflector segments (2-5) which are arranged to form together the dome shaped structure wherein at least two of said reflector segments (2-5) have different reflection characteristics.
2. Reflector assembly according to claim 1, wherein the reflector segments (2-5) form a continuously shaped reflective surface.
3. Reflector assembly according to claim 1 or 2, wherein said reflector segments (2-6) comprise one central reflector segment (2) and at least two periphery reflector segments (3-5) extending from the central reflector segment (2) to the opening of the dome shaped structure.
4. Reflector assembly according to claim 3, wherein said periphery reflector segments (3-5) substantially have an identical shape.
5. Reflector assembly according to claim 4, wherein said reflector segments (2-5) comprise one central reflector segment (2) and four periphery reflector segments (3-5).
6. Reflector assembly according to claim 5, wherein two opposed periphery reflector segments (3) have identical reflection characteristics.
7. Reflector assembly according to any one of the preceding claims, wherein said reflector segments (2-5) are adapted to form at least one opening in the reflective surface for inserting or holding a light source (100).
8. Reflector assembly according to any one of the preceding claims, comprising further means for connecting the reflector segments (2-5) to each other.
9. Method for manufacturing a dome shaped reflector (1) comprising assembling a plurality of reflector segments (2-5)

to form together the dome shaped structure, wherein at least two of said reflector segments (2-5) have different reflection characteristics.

- 5
10. Method for manufacturing a dome shaped reflector according to claim 9, wherein the reflector segments (2-5) form a continuously shaped reflective surface.
- 10
11. Method for manufacturing a dome shaped reflector according to claim 9 or 10, wherein said reflector segments (2-6) comprise one central reflector segment (2) and at least two periphery reflector segments (3-5) extending from the central reflector segment (2) to the opening of the dome shaped structure.
- 15
12. Method for manufacturing a dome shaped reflector according to claim 11, wherein said periphery reflector segments (3-5) substantially have an identical shape.
- 15
13. Method for manufacturing a dome shaped reflector according to claim 12, wherein said reflector segments (2-5) comprise one central reflector segment (2) and four periphery reflector segments (3-5).
- 20
14. Method for manufacturing a dome shaped reflector according to claim 13, wherein two opposed periphery reflector segments (3) have identical reflection characteristics.
- 25
- 30
- 35
- 40
- 45
- 50
- 55
15. Method for manufacturing a dome shaped reflector according to one of claims 9 to 14, wherein said reflector segments (2-5) are adapted to form at least one opening in the reflective surface for inserting or holding a light source (100).

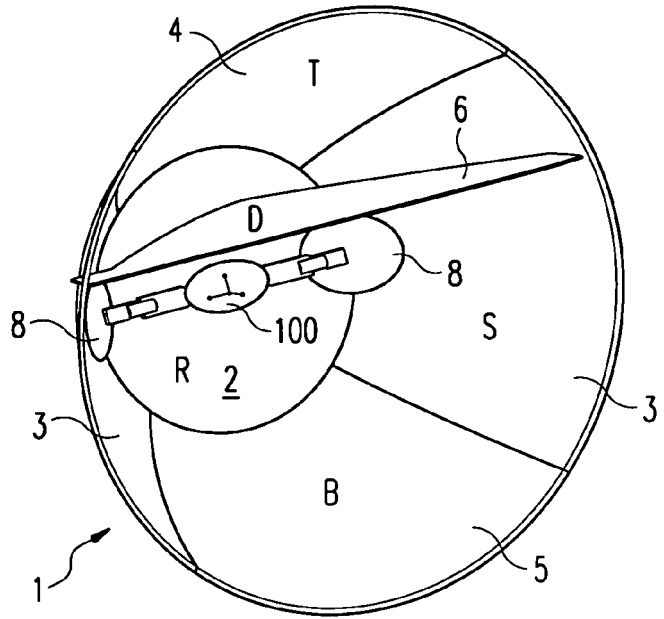

Fig. 1

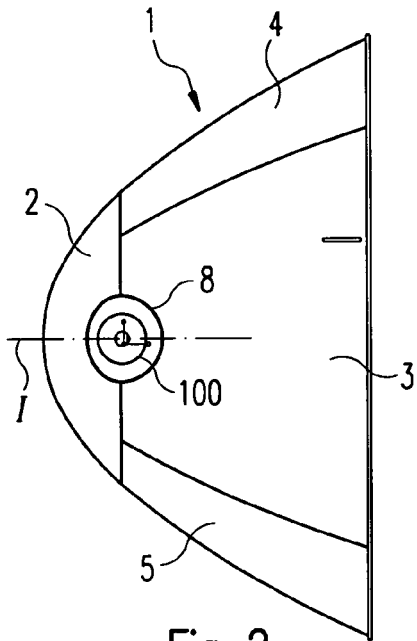

Fig. 2

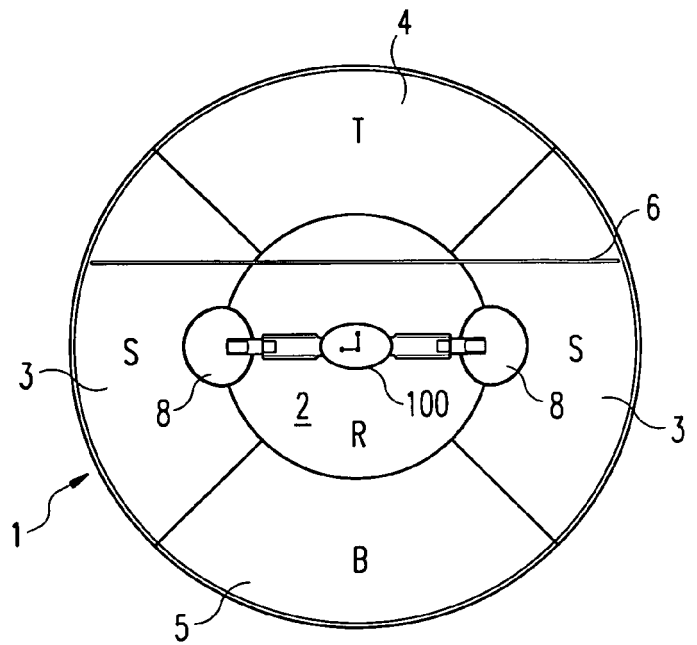

Fig. 3

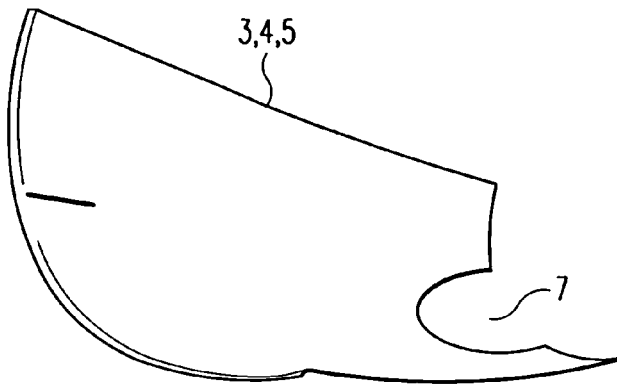

Fig. 4

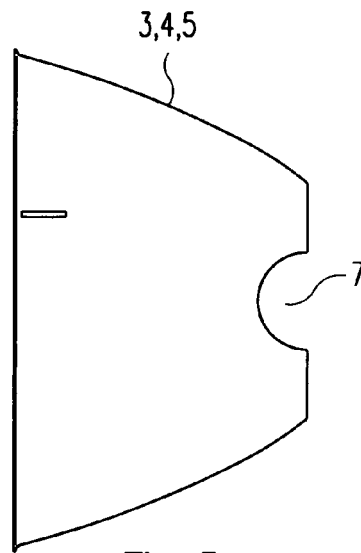

Fig. 5

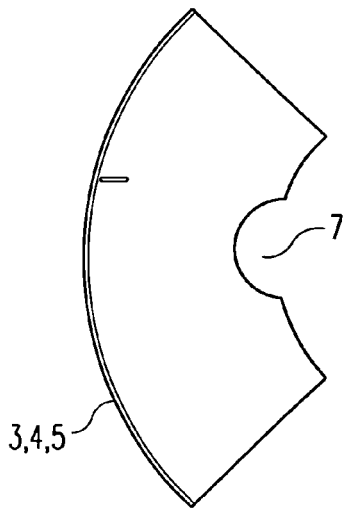

Fig. 6

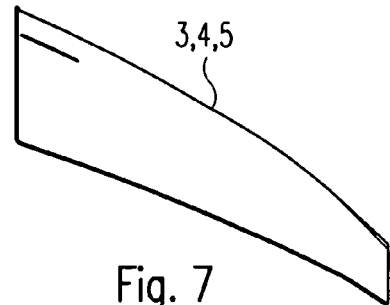

Fig. 7

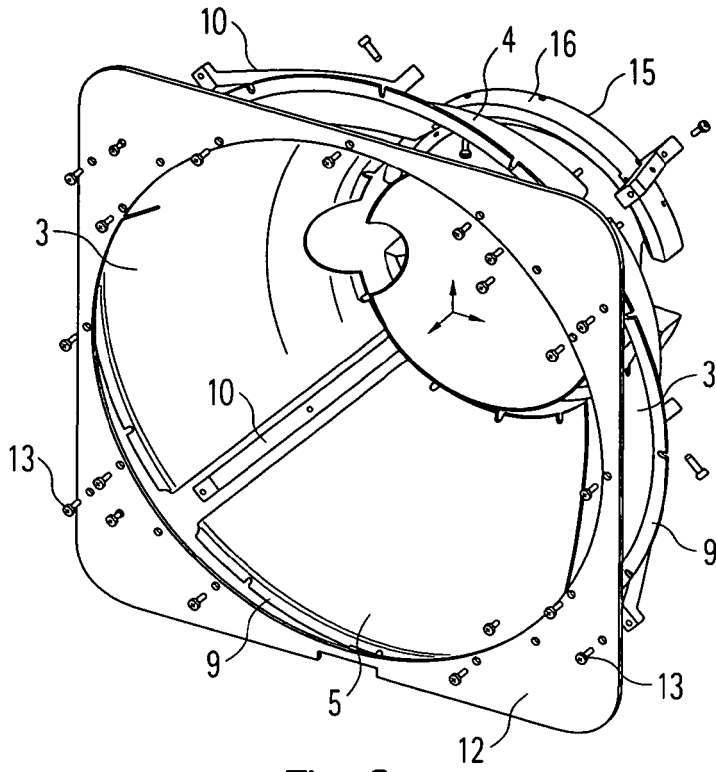

Fig. 8

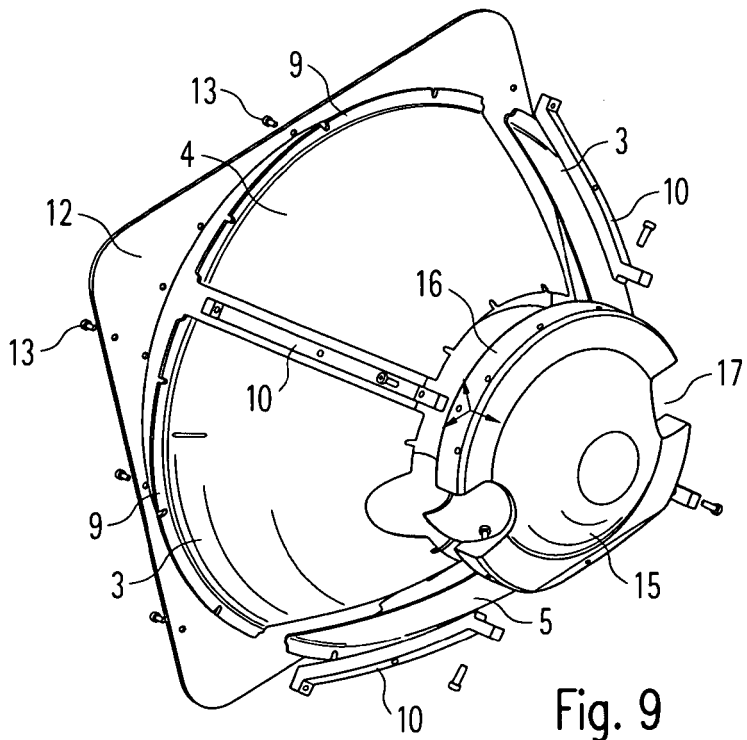

Fig. 9

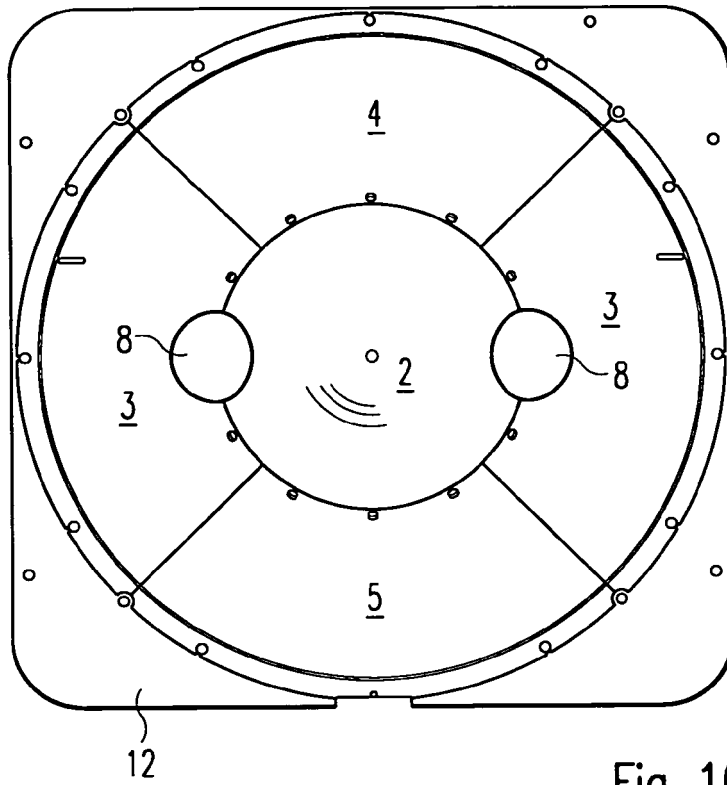

Fig. 10

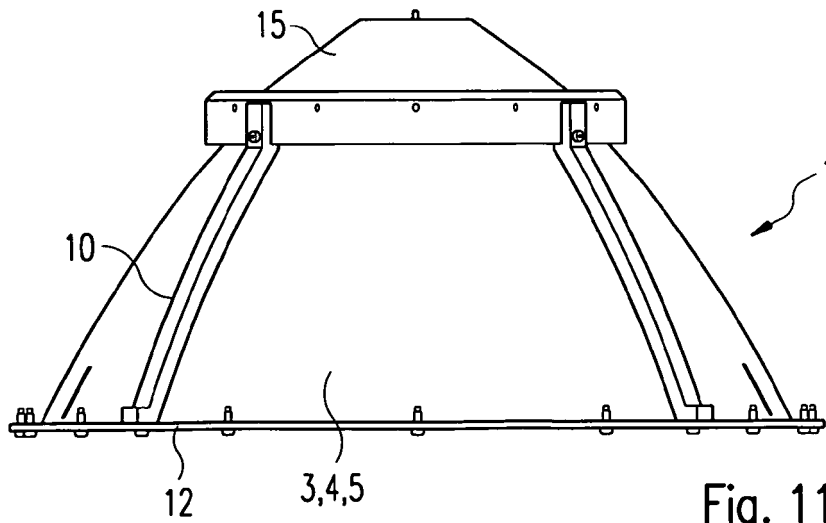

Fig. 11

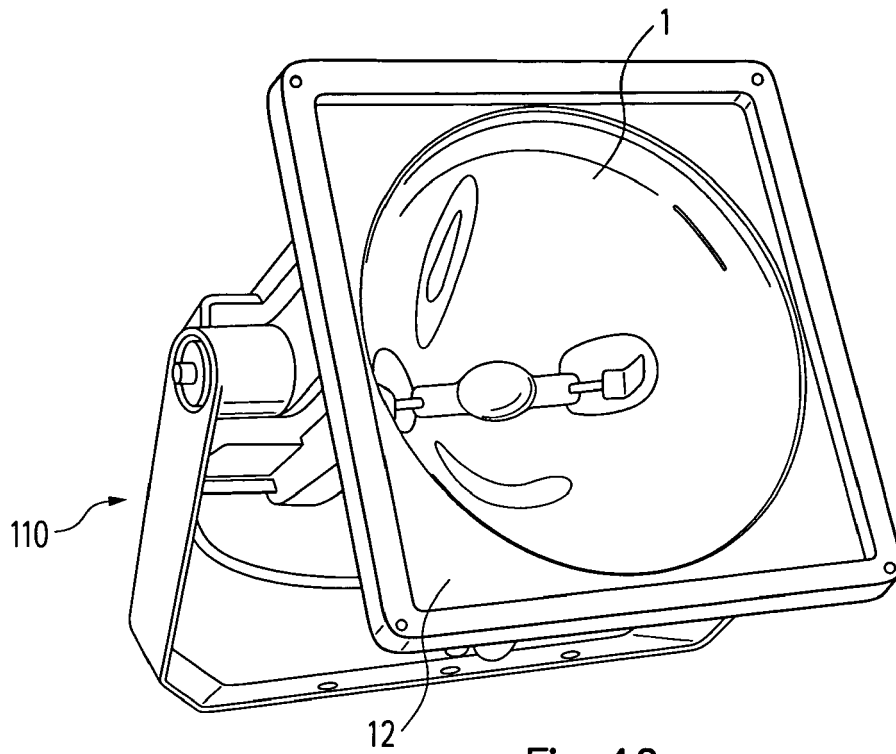

Fig. 12



EUROPEAN SEARCH REPORT

Application Number
EP 12 29 0085

DOCUMENTS CONSIDERED TO BE RELEVANT			
Category	Citation of document with indication, where appropriate, of relevant passages	Relevant to claim	CLASSIFICATION OF THE APPLICATION (IPC)
X	US 5 287 259 A (LAUTZENHEISER TERRY L [US]) 15 February 1994 (1994-02-15) * column 1, line 11 - column 2, line 35 * * column 3, line 14 - line 30 * * column 4, line 57 - column 6, line 28 * * column 6, line 65 - column 7, line 19 * * column 7, line 59 - line 63 * * figures 1,2,3,11,12,15,16 * -----	1,2, 7-10,15	INV. F21V7/00 F21V7/10 F21V7/22 F21V17/00 ADD. F21W131/105 F21W131/107
X	US 707 982 A (TAYLOR HORACE H [US]) 26 August 1902 (1902-08-26) * page 1, line 12 - line 38 * * page 1, line 64 - line 75 * * figures 1-3 * -----	1,3-9, 11-15	
X	US 2009/268456 A1 (MEHRTENS ANDREE [DE] ET AL) 29 October 2009 (2009-10-29) * paragraphs [0019], [0020], [0026], [0027], [0031] * * figures 1,4 * -----	1-15	
X	US 6 203 176 B1 (GORDIN MYRON K [US]) 20 March 2001 (2001-03-20) * column 1, line 9 - line 12 * * column 4, line 1 - column 6, line 20 * * column 7, line 22 - line 60 * * figures 1-3 * -----	1,2, 7-10,15	TECHNICAL FIELDS SEARCHED (IPC) F21V
X	US 6 382 803 B1 (ARUMUGASAAMY PANCHADSARAM [US]) 7 May 2002 (2002-05-07) * column 4, line 24 - line 50 * * column 5, line 63 - column 6, line 5 * * column 6, line 37 - column 7, line 10 * * figures 3,4,6,8,22,23 * ----- -/--	1-15	
The present search report has been drawn up for all claims			
Place of search Munich		Date of completion of the search 17 August 2012	Examiner Arsac England, Sally
CATEGORY OF CITED DOCUMENTS X : particularly relevant if taken alone Y : particularly relevant if combined with another document of the same category A : technological background O : non-written disclosure P : intermediate document		T : theory or principle underlying the invention E : earlier patent document, but published on, or after the filing date D : document cited in the application L : document cited for other reasons ----- & : member of the same patent family, corresponding document	

2
EPO FORM 1503 03.02 (P04C01)



EUROPEAN SEARCH REPORT

Application Number
EP 12 29 0085

DOCUMENTS CONSIDERED TO BE RELEVANT			
Category	Citation of document with indication, where appropriate, of relevant passages	Relevant to claim	CLASSIFICATION OF THE APPLICATION (IPC)
X	US 5 971 569 A (SMITH A MICHAEL [US] ET AL) 26 October 1999 (1999-10-26) * column 2, line 20 - line 34 * * column 3, line 22 - line 52 * * figure 1 * -----	1,2,7-10	
A	US 6 152 583 A (LANGNER ALEJANDRO-MIER [US]) 28 November 2000 (2000-11-28) * column 4, line 45 - line 67 * * figures 1,2 * -----	1-15	
A	JP 2007 250231 A (MITSUBISHI ELECTRIC CORP; MITSUBISHI ELEC LIGHTING CORP) 27 September 2007 (2007-09-27) * abstract * * figures 1,4 * -----	1,8,9	
			TECHNICAL FIELDS SEARCHED (IPC)
The present search report has been drawn up for all claims			
Place of search Munich		Date of completion of the search 17 August 2012	Examiner Arsac England, Sally
<p>CATEGORY OF CITED DOCUMENTS</p> <p>X : particularly relevant if taken alone Y : particularly relevant if combined with another document of the same category A : technological background O : non-written disclosure P : intermediate document</p> <p>T : theory or principle underlying the invention E : earlier patent document, but published on, or after the filing date D : document cited in the application L : document cited for other reasons & : member of the same patent family, corresponding document</p>			

EPO FORM 1503 03.82 (P04C01)

**ANNEX TO THE EUROPEAN SEARCH REPORT
ON EUROPEAN PATENT APPLICATION NO.**

EP 12 29 0085

This annex lists the patent family members relating to the patent documents cited in the above-mentioned European search report. The members are as contained in the European Patent Office EDP file on
The European Patent Office is in no way liable for these particulars which are merely given for the purpose of information.

17-08-2012

Patent document cited in search report	Publication date	Patent family member(s)	Publication date
US 5287259 A	15-02-1994	NONE	
US 707982 A	26-08-1902	NONE	
US 2009268456 A1	29-10-2009	CN 101571261 A DE 102008021550 A1 US 2009268456 A1	04-11-2009 29-10-2009 29-10-2009
US 6203176 B1	20-03-2001	NONE	
US 6382803 B1	07-05-2002	NONE	
US 5971569 A	26-10-1999	NONE	
US 6152583 A	28-11-2000	CA 2247233 A1 US 6152583 A	20-08-1999 28-11-2000
JP 2007250231 A	27-09-2007	JP 4598699 B2 JP 2007250231 A	15-12-2010 27-09-2007