

(19) World Intellectual Property Organization
International Bureau



(43) International Publication Date
22 June 2006 (22.06.2006)

PCT

(10) International Publication Number
WO 2006/065628 A1

- (51) International Patent Classification:
F02M 63/00 (2006.01) F02M 51/00 (2006.01)
F02M 61/08 (2006.01)
- (21) International Application Number:
PCT/US2005/044481
- (22) International Filing Date:
8 December 2005 (08.12.2005)
- (25) Filing Language: English
- (26) Publication Language: English
- (30) Priority Data:
11/009,035 13 December 2004 (13.12.2004) US
- (71) Applicant (for all designated States except US): SYN-
ERJECT, LLC [US/US]; 201 Enterprise Drive, Newport
News, Virginia 23603 (US).
- (72) Inventor; and
- (75) Inventor/Applicant (for US only): CATASUS-SERVIA,

Jordi [CA/US]; 104 Queen Anne Drive, Williamsburg,
Virginia 23185 (US).

(74) Agents: VASHAW, Nancy et al.; Cooley Godward, LLP,
One Freedom Square, Reston Town Centre, 11951 Free-
dom Drive, Reston, Virginia 20190-5601 (US).

(81) Designated States (unless otherwise indicated, for every
kind of national protection available): AE, AG, AL, AM,
AT, AU, AZ, BA, BB, BG, BR, BW, BY, BZ, CA, CH, CN,
CO, CR, CU, CZ, DE, DK, DM, DZ, EC, EE, EG, ES, FI,
GB, GD, GE, GH, GM, HR, HU, ID, IL, IN, IS, JP, KE,
KG, KM, KN, KP, KR, KZ, LC, LK, LR, LS, LT, LU, LV,
LY, MA, MD, MG, MK, MN, MW, MX, MZ, NA, NG, NI,
NO, NZ, OM, PG, PH, PL, PT, RO, RU, SC, SD, SE, SG,
SK, SL, SM, SY, TJ, TM, TN, TR, TT, TZ, UA, UG, US,
UZ, VC, VN, YU, ZA, ZM, ZW.

(84) Designated States (unless otherwise indicated, for every
kind of regional protection available): ARIPO (BW, GH,
GM, KE, LS, MW, MZ, NA, SD, SL, SZ, TZ, UG, ZM,
ZW), Eurasian (AM, AZ, BY, KG, KZ, MD, RU, TJ, TM),
European (AT, BE, BG, CH, CY, CZ, DE, DK, EE, ES, FI,

[Continued on next page]

(54) Title: FUEL INJECTOR ASSEMBLY AND POPPET

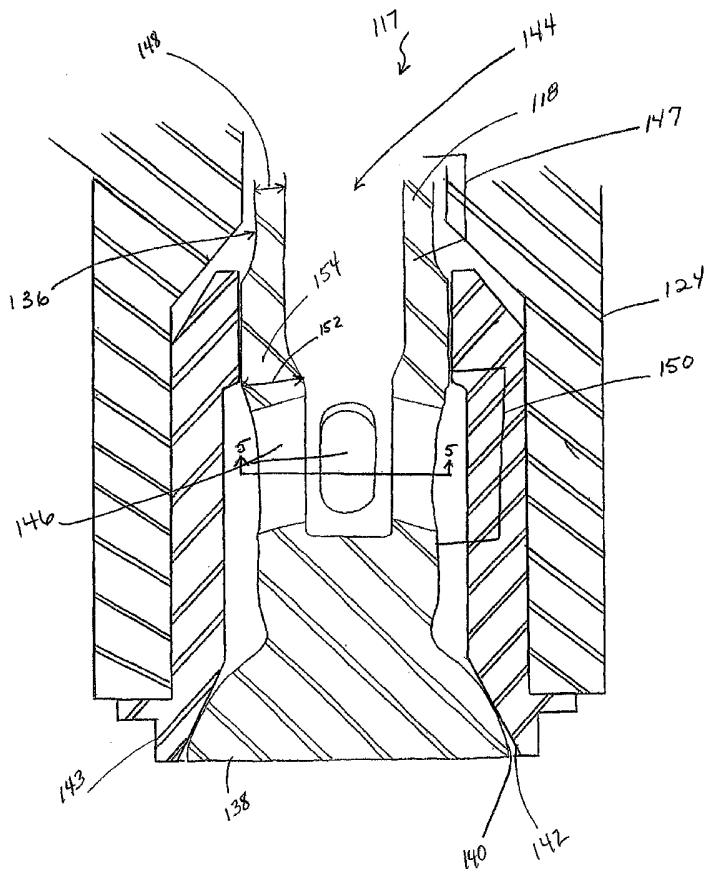

(57) Abstract: An assembly for a fuel injector (100) includes a fluid transportation member (118) having a first portion (147) that defines an internal passageway (144) configured to convey fluid through the first portion (147), and second portion (150) in fluid communication with the first portion (147). The second portion (150) defines at least one conduit (146) configured to communicate fluid from the internal passageway (144) out of the fluid transportation member (118) and a structural reinforcement portion (154, 158) is collocated with the second portion (150). A housing (124) is configured to receive at least a portion of the fluid transportation member (118).

WO 2006/065628 A1



FR, GB, GR, HU, IE, IS, IT, LT, LU, LV, MC, NL, PL, PT,
RO, SE, SI, SK, TR), OAPI (BF, BJ, CF, CG, CI, CM, GA,
GN, GQ, GW, ML, MR, NE, SN, TD, TG).

Published:

- *with international search report*
- *before the expiration of the time limit for amending the claims and to be republished in the event of receipt of amendments*

Declaration under Rule 4.17:

- *as to applicant's entitlement to apply for and be granted a patent (Rule 4.17(ii))*

For two-letter codes and other abbreviations, refer to the "Guidance Notes on Codes and Abbreviations" appearing at the beginning of each regular issue of the PCT Gazette.

FUEL INJECTOR ASSEMBLY AND POPPET

BACKGROUND

[001] The present invention relates to fuel injectors, and more particularly to an assembly and poppet for use in fuel injectors.

[002] Conventional fuel injectors are configured to deliver a quantity of fuel to a combustion cylinder of an engine. To increase combustion efficiency and decrease pollutants, it is desirable to atomize the delivered fuel. Generally speaking, atomization of fuel can be achieved by supplying high pressure fuel to conventional fuel injectors, or by atomizing low pressure fuel with pressurized gas, i.e., "air assist fuel injection."

[003] A conventional air assist fuel injector receives a metered quantity of low pressure fuel from a conventional fuel injector (not illustrated) and pressurized air from a rail (not illustrated). The air assist fuel injector atomizes the low pressure fuel with the pressurized air as it conveys the air and fuel mixture to the combustion chamber of an engine.

[004] The pressurized air from the rail and the metered quantity of fuel from the conventional fuel injector enter the air assist fuel injector through a cap, which delivers the fuel and air to a conduit of an armature. Thereafter, the fuel and air travel through a passageway of a fluid transportation member or poppet, and exit the poppet through small slots near the end or head of the poppet. The poppet is typically attached to the armature, which is actuated by energizing a solenoid coil. When the solenoid coil is energized, the armature will overcome the force of a spring and move. Because the poppet is attached to the armature, the head of the poppet will lift off a seat when the armature is actuated so that the metered quantity of fuel is atomized as it is delivered to the combustion chamber of the engine. Hence, besides conveying liquid fuel and air, the poppet repeatedly opens to inject fuel and closes to define a seal that prevents the injection of fuel. Because of this function, the poppet is a critical component of most fuel injectors and is typically fabricated from a high strength, tough, and wear resistant material, such as AISI 440 stainless steel. For example, the conventional poppet is typically formed from stainless steel bar stock by: (1) machining the bar stock to a cylindrical blank; (2) gun-drilling the internal cylindrical passageway of the poppet; (3) heat treating the part; (4) grinding the exterior surface of the

passageway of the poppet; (3) heat treating the part; (4) grinding the exterior surface of the poppet; and (5) electrical discharge machining (“EDM”) the slots. Unfortunately, it was discovered that the intersection between the gun-drilling of the internal passageway and the formation of the slots in the poppet via the EDM process produces stress concentration areas. These stress concentration areas, in conjunction with the micro-cracks typically resulting from the EDM process, have caused the poppet to fail at or near the slots. Additionally, it is difficult to bore the internal and elongated passageway of the poppet and there are reported failures due to excessive run-out during this operation. Despite these problems, the above-described manufacturing process was thought to be the only suitable method of manufacturing the poppet, largely because the shape, features, and requirements of conventional poppets are not well-suited for other, traditional fabrication processes.

SUMMARY

[005] An assembly for a fuel injector includes a fluid transportation member having a first portion defining an internal passageway configured to convey fluid through the first portion, and a second portion in fluid communication with the first portion. The second portion defines at least one conduit configured to communicate fluid from the internal passageway out of the fluid transportation member, and a structural reinforcement portion is collocated with the second portion. A housing is configured to receive at least a portion of the fluid transportation member.

[006] Other advantages and features associated with the embodiments of the present invention will become more readily apparent to those skilled in the art from the following detailed description. As will be realized, the invention is capable of other and different embodiments, and its several details are capable of modification in various obvious aspects, all without departing from the invention. Accordingly, the drawings in the description are to be regarded as illustrative in nature, and not limitative.

BRIEF DESCRIPTION OF THE DRAWINGS

[007] FIG. 1 is a cross-sectional view of an air assist fuel injector according to one embodiment of the invention.

[0008] FIG. 2A is cross-sectional view of a portion of a fluid transportation member according to one embodiment of the invention.

[0009] FIG. 2B is cross-sectional view of a portion of a drilled fluid transportation member.

[0010] FIG. 3 is a perspective view of a portion of a transportation member illustrating a failure mode.

[0011] FIG. 4 is a cross-sectional view of a portion of an assembly for an air assist fuel injector according to one embodiment of the invention.

[0012] FIG. 5 is a cross-sectional view taken along line 5-5 in FIG. 4.

[0013] FIG. 6 is a cross-sectional view of a portion of a fluid transportation member according to one embodiment of the invention.

[0014] FIG. 7 is a cross-sectional view taken along line 7-7 in FIG. 6.

[0015] FIG. 8 is a cross-sectional view of a portion of a fluid transportation member according to one embodiment of the invention.

[0016] FIGS. 9A and 9B are each cross-sectional views taken along line 9A-9A and 9B-9B respectively in FIG. 8.

[0017] FIG. 10 is a cross-sectional view of a portion of a fluid transportation member according to one embodiment of the invention.

[0018] FIG. 11A and 11B are both optional cross-sectional views taken along lines 11A-11A and 11B-11B respectively in FIG. 10.

[0019] FIG. 11C is a cross-sectional view taken along line 11C-11C in FIG. 10.

[0020] FIG. 12 is a cross-sectional view of a portion of a fluid transportation member according to one embodiment of the invention.

[0021] FIG. 13 is a cross-sectional view taken along line 13-13 in FIG. 12.

[0022] FIG. 14 is a perspective view of a reinforcement insert according to one embodiment of the invention.

[0023] FIG. 15 is a cross-sectional view of a portion of a fluid transportation member according to one embodiment of the invention including a reinforcement insert.

[0024] FIG. 16 is a cross-sectional view of a portion of a fluid transportation member according to one embodiment of the invention including a reinforcement insert.

DETAILED DESCRIPTION

[0025] FIG. 1 generally illustrates an air assist fuel injector 100 incorporating one embodiment of the invention. The air assist fuel injector 100 is configured to utilize pressurized gas to atomize low pressure liquid fuel, which together travel through the air assist fuel injector along a direction of flow f as indicated in FIG. 1. In some embodiments, the air assist fuel injector 100 is configured for use with a two-stroke internal combustion engine. When installed in an engine, the air assist fuel injector 100 is located such that the atomized low pressure fuel that exits the injector 100 is delivered to the internal combustion chamber of an engine. For example, the injector 100 may be located in a cavity of a two-stroke internal combustion engine head such that the fuel injector delivers a metered quantity of atomized liquid fuel to the combustion cylinder of the two-stroke internal combustion engine where it is ignited by a spark plug or otherwise. In alternative embodiments the air assist fuel injector is configured for operation with other engines and other applications. For example, the air assist fuel injector 100 may be configured for operation with a four stroke internal combustion engine or a rotary engine and may inject liquids other than fuel.

[0026] In some embodiments, the air assist fuel injector 100 is located adjacent a conventional fuel injector (not illustrated), which delivers metered quantities of fuel to the air assist fuel injector. The conventional fuel injector may be located in the cavity of a rail or within a cavity in the head of an engine. The air assist fuel injector 100 is referred to as "air assist" because it preferably utilizes pressurized air to atomize liquid fuel. Although it is preferred that the air assist fuel injector 100 atomize liquid gasoline with pressurized air, it will be appreciated that the air assist fuel injector 100 may atomize many other liquids with any variety of gases. For example, the air assist fuel injector 100 may atomize oil, water, kerosene, or liquid methane with pressurized gaseous oxygen, propane, or exhaust gas. Hence, the term "air assist fuel injector" is a term of art, and as used herein is not intended to

dictate that the air assist fuel injector 100 be used only with pressurized air and only with liquid fuel.

[0027] The air assist fuel injector 100 shown in FIG. 1 includes a housing 124, a poppet 118 attached to an armature 116, and a seat member 143. Seat member 143 may be a separate component as shown or alternatively, may be formed integrally with housing 124. Because poppet 118 is attached to armature 116, poppet 118 will move with armature 116 when armature 116 is actuated by an energized solenoid coil 115. Poppet 118 shown in FIG. 1 is a member that opens and closes to control the discharge of fuel from the fuel injector 100. Poppet 118 includes a head 138, a stem 136, and an internal passageway 144 that extends from an inlet 132 to an outlet or conduit 146 located upstream of head 138. Poppet 118 is also received within housing 124. When poppet 118 opens and closes, it reciprocates within a channel 134 of housing 124. Head 138 includes a sealing surface 140 that abuts an impact surface 142 of seat member 143 when the fuel injector is closed. When the fuel injector is open, sealing surface 140 is spaced away from the impact surface 142 as poppet 118 is moved in a direction with the flow of fluid. In another embodiment, the poppet 118 is an inwardly opening poppet. That is, to discharge the fuel from the fuel injector, the poppet and armature move opposite the direction of flow f such that the poppet head 138 lifts inwardly off of seat 143 to discharge fuel from the air assist fuel injector.

[0028] A cross-sectional view of a portion of an assembly 117 for an air assist fuel injector is shown in FIG. 4. Assembly 117 includes a fluid transportation member or poppet 118 received within a housing 124, and a seat member 143. Assembly 117 and/or poppet 118 may be incorporated in a typical air assist fuel injector such as the one described above.

[0029] Poppet 118 includes an improved structural configuration and may be manufactured utilizing a number of different processes. These processes were previously thought to be an unsuitable method of manufacturing a poppet, largely because of the shape, features, and requirements of conventional poppets. Such processes include casting, molding, metal injection molding (MIM), cold heading, cold forging and powdered metal processing, all of which are known processes available in the art. For example, a MIM process, which uses machinery similar to plastic injection molding, can be used to mold a poppet blank. The MIM process involves molding a poppet blank from a powdered metal mix that includes a binder. After molding, the binder is removed from the poppet blank through a heating/melt process. The poppet blank then undergoes a sintering, heat treating and grinding process. Poppet 118

may be fabricated from a variety of different metallic materials such as iron, aluminum, titanium, and their alloys, as well as austenitic, ferritic, or martensitic stainless steel and 400 series stainless steel.

[0030] The portion of an assembly 117 shown in FIG. 4 is a cross-sectional view taken along a line cut longitudinally through the center of an assembly 117. FIG. 5 illustrates a cross-sectional view of a portion of the poppet 118 shown in FIG. 4 taken along a line cut laterally through a portion of the outlets 146 of poppet 118 and pointing in a direction opposite the flow f . As illustrated in FIGS. 4 and 5, poppet 118 includes a first portion 147 having a first wall thickness 148 and a second portion 150 having a second wall thickness 152. The first portion 147 includes at least a portion of the stem 136 of poppet 118. In some embodiments, second wall thickness 152 is larger than first wall thickness 148 and includes a structural reinforcement portion 154 collocated with second wall thickness 152. Processes used to manufacture poppet 118 enable the formation of multiple wall thicknesses along poppet 118 such as the larger wall thickness 152 of second portion 150. In addition, the interior surface of a poppet 118 is devoid of tool marks and sharp edges, as shown in FIG. 2A. In comparison, a poppet configured and manufactured with conventional designs and methods can contain sharp transition edges S as a result of the gundrill process to bore the internal passageway of the poppet as shown in FIG. 2B. Sharp edges such as those shown in FIG. 2B are a primary cause of failures in conventional poppets, as a fracture typically occurs in this location between the outlets. An illustration of an example poppet that has failed due to the presence of sharp edges and associated fatigue points/weaknesses is shown in FIG. 3.

[0031] In the embodiment shown in FIG. 4, the second portion 150 and the first portion 147 are in fluid communication with one another in that fluid flows through internal passageway 144 of poppet 118 and passes through first portion 147 and second portion 150. At least one outlet or conduit 146 is located on poppet 118 within second portion 150. Conduit(s) 146 permits the fluid to exit from poppet 118 when the solenoid 116 is activated and poppet 118 is moved to an open position. The embodiment shown in FIG. 4 illustrates poppet 118 with second portion 150 having four conduits 146 (three of which are visible in FIG. 4). In this embodiment, second portion 150 and structural reinforcement portion 154 include a cross-sectional perimeter having a substantially constant wall thickness and substantially circular shape, as shown in FIG. 5.

[0032] In alternative embodiments, poppet 118 may be configured with one or more conduits 146, and a variety of different wall thicknesses and shapes. For example, as illustrated in FIGS. 6 and 7, second portion 150 includes a cross-sectional perimeter and reinforcement portion 154 having a constant wall thickness, but with only a single conduit 146. FIG. 6 illustrates a cross-sectional view of a portion of a poppet 118 taken along a line cut longitudinally through the center of poppet 118, and FIG. 7 illustrates a cross-sectional view of a portion of the poppet 118 taken along a line cut laterally through a portion of the outlets 146 of poppet 118 and pointing in a direction opposite the flow *f*.

[0033] FIG. 8 illustrates a cross-sectional view of a portion of a poppet 118 taken along a line cut longitudinally through the center of a poppet 118, and FIGS. 9A and 9B illustrate a cross-sectional view of a portion of the poppet 118 taken along lines cut laterally through the poppet 118 and pointing in a direction opposite the flow *f*. FIG. 9B is a view from a line cut laterally through a portion of the outlets 146 and FIG. 9A is a view from a line cut laterally through first portion 147. FIGS. 8, 9A and 9B illustrate an embodiment with a first portion 147 having a non-circular cross-sectional perimeter and varying wall thickness (FIG. 9A) and a second portion 150 having a non-circular cross-sectional perimeter, two conduits 146 and a non-circular structural reinforcement portion 154 with varying wall thicknesses (Figure 9B). Internal passageway 144 may be a variety of different shapes and sizes and may vary in size and shape along the length of poppet 118.

[0034] Structural reinforcement portion 154 may also include at least one buttress 156 formed on either an interior surface or exterior surface of poppet 118. Buttress(es) 156 may be formed by a number of different processes such as casting, molding, metal injection molding, cold heading, cold forging, and powdered metal processing. FIG. 10 is a cross-sectional view of a portion of a poppet 118 taken along a line cut longitudinally through the center of poppet 118 and illustrates a poppet 118 having four buttresses 156 (two of which are illustrated) disposed between adjacent conduits 146 on interior surface 164 of poppet 118. FIGS. 11A and 11B illustrate two possible cross-sectional views of poppet 118 taken along a line cut laterally through a portion of the outlets 146 of poppet 118 and pointing in a direction opposite the flow *f*. FIG. 11A illustrates the second portion 150 having a cross-sectional perimeter with a substantially constant wall thickness and FIG. 11B illustrates a cross-sectional perimeter of second portion 150 having a non-constant wall thickness. FIG. 11C

illustrates a cross-sectional perimeter of the first portion 147 with a substantially constant wall thickness.

[0035] A variety of buttress configurations, shapes and sizes may be incorporated, including positioning the buttresses 156 on the outer surface of poppet 118 as shown in FIGS. 12 and 13. FIG. 12 illustrates a cross-sectional view of a portion of a poppet 118 taken along a line cut longitudinally through a center of poppet 118, and FIG. 13 illustrates a cross-sectional view of a portion of the poppet 118 taken along a line cut laterally through the outlets 146 of poppet 118 and pointing in a direction opposite the flow f . In this embodiment of poppet 118, the cross-sectional perimeter includes a non-constant or variable wall thickness, but it is to be understood that a constant wall thickness may also be utilized.

[0036] In another embodiment of the invention, a reinforcement member 158 may be coupled to second portion 150 to further reinforce second portion 150. Reinforcement member 158 may be used alone or in combination with reinforcement portion 154. It includes apertures or openings 159 arranged to align with outlets 146 when reinforcement member 158 is operatively coupled to poppet 118. Reinforcement member 158, may be coupled to second portion 150 on an interior surface 164 of poppet 118, as shown in FIG. 15. The coupling may be accomplished by a variety of known attachment methods such as welding, friction fit or threaded fasteners. Alternatively, reinforcement member 158 may be configured to couple to second portion 150 on an exterior surface 166 of poppet 118, as shown in FIG. 16. Reinforcement member 158 may be fabricated from a metallic material, such as iron, aluminum, titanium, and their alloys, ferretic, as well as austenitic or martensitic stainless steel. Reinforcement member 158 provides further reinforcement and strength to poppet 118 to further eliminate product failures.

[0037] The fluid transportation members described above and other poppets fabricated as described herein may be used with fuel injectors with differing constructions where fuel is discharged in the form of a plume, including inwardly and outwardly opening fuel injectors where fuel alone is injected and where fuel is entrained in a gas, such as air.

[0038] The principles, embodiments, and modes of operation of the present invention have been described in the foregoing description. However, the invention which is intended to be protected is not to be construed as limited to the particular embodiments disclosed. Further, the embodiments described herein are to be regarded as illustrative rather than restrictive.

Variations and changes may be made by others, and equivalents employed, without departing from the spirit of the present invention. Accordingly, it is expressly intended that all such variations, changes, and equivalents that fall within the spirit and scope of the present invention as defined in the claims be embraced thereby.

CLAIMS

1. An assembly for a fuel injector, comprising:
 - a fluid transportation member having
 - a first portion defining an internal passageway configured to convey fluid through said first portion,
 - a second portion in fluid communication with said first portion, said second portion defining at least one conduit configured to communicate fluid from said internal passageway out of said fluid transportation member, and
 - a structural reinforcement portion collocated with said second portion;
 - and
 - a housing configured to receive at least a portion of said fluid transportation member.
2. The assembly of claim 1, wherein said fluid transportation member is configured to move relative to said housing.
3. The assembly of claim 1, wherein said fluid transportation member is a poppet configured to move linearly along a longitudinal axis of said assembly.
4. The assembly of claim 1, wherein said fluid transportation member is an outwardly opening poppet.
5. The assembly of claim 1, wherein said second portion has a cross-sectional perimeter, said cross-sectional perimeter being of a non-circular shape.
6. The assembly of claim 1, wherein said fluid transportation member has a first wall thickness associated with said first portion, and a second wall thickness associated with said second portion, said second wall thickness being greater than said first wall thickness, and said structural reinforcement portion being associated with said second wall thickness.

7. The assembly of claim 6, wherein said second portion has a cross-sectional perimeter, said second wall thickness being substantially constant about said cross-sectional perimeter.
8. The assembly of claim 1, wherein said at least one conduit is one conduit from a plurality of conduits, each of which is configured to communicate fluid from said internal passageway out of said fluid transportation member, and said structural reinforcement portion includes a plurality of buttresses, each of said plurality of buttresses being disposed between adjacent ones of said plurality of conduits.
9. The assembly of claim 8, wherein said plurality of buttresses are located on an exterior surface of said second portion.
10. The assembly of claim 8, wherein said plurality of buttresses are formed by one of casting, molding, metal injection molding, cold heading, cold forging, and powdered metal processing.
11. The assembly of claim 1, wherein said fluid transportation member is constructed from a metallic material.
12. The assembly of claim 1, wherein at least a portion of said internal passageway is devoid of substantially sharp edges.
13. The assembly of claim 12, wherein said at least a portion of said internal passageway is defined within said second portion.
14. The assembly of claim 1, wherein at least a portion of said internal passageway is devoid of tooling marks.
15. The assembly of claim 14, wherein said at least a portion of said internal passageway is defined within said second portion.
16. An assembly for a fuel injector, comprising:
 - a fluid transportation member having

a first portion defining an internal passageway configured to convey fluid through said first portion, said first portion having a first wall thickness,
a second portion in fluid communication with said first portion defining at least one conduit configured to communicate fluid from said internal passageway out of said fluid transportation member, said second portion having a second wall thickness, said second wall thickness being greater than said first wall thickness; and
a housing configured to receive at least a portion of said fluid transportation member.

17. The assembly of claim 16, wherein said fluid transportation member is configured to move relative to said housing.

18. The assembly of claim 16, wherein said fluid transportation member is a poppet configured to move linearly along a longitudinal axis of said assembly.

19. The assembly of claim 16, wherein said fluid transportation member is an outwardly opening poppet.

20. The assembly of claim 16, wherein said second portion has a cross-sectional perimeter, said second wall thickness being substantially constant about said perimeter.

21. The assembly of claim 16, wherein said at least one conduit is one conduit from a plurality of conduits, each of which is configured to communicate fluid from said internal passageway out of said fluid transportation member; and said second portion has a cross-sectional perimeter and said second wall thickness is substantially variable about said cross-sectional perimeter.

22. The assembly of claim 16, wherein at least a portion of said internal passageway is devoid of substantially sharp edges.

23. The assembly of claim 22, wherein said at least a portion of said internal passageway is defined within said second portion.

24. An assembly for a fuel injector, comprising:

a fluid transportation member having

a first portion defining an internal passageway configured to convey fluid through said first portion, and

a second portion in fluid communication with said first portion, said second portion defining at least one conduit configured to communicate fluid from said internal passageway out of said fluid transportation member;

a reinforcement member coupled to, and configured to reinforce said second portion; and

a housing configured to receive at least a portion of said fluid transportation member.

25. The assembly of claim 24, wherein said fluid transportation member is configured to move relative to said housing member.

26. The assembly of claim 24, wherein said fluid transportation member is a poppet configured to move linearly along a longitudinal axis of said assembly

27. The assembly of claim 24, wherein said fluid transportation member is an outwardly opening poppet.

28. The assembly of claim 24, wherein said reinforcement member is coupled to said fluid transportation member by one of welding, interference fit, chemical bonding, coating process, mechanical fastener, and crimping.

29. The assembly of claim 24, wherein said reinforcement member is configured to be located adjacent to said at least one conduit.

30. The assembly of claim 24, wherein said reinforcement member is configured to be attached to an exterior surface of said fuel transportation member adjacent to said at least one conduit.

31. The assembly of claim 24, wherein said reinforcement member is configured to be attached to an interior surface within said internal passageway.

32. A fluid transportation member, comprising:

a first portion defining an internal passageway configured to convey a fluid through said first portion,

a second portion in fluid communication with said first portion, said second portion defining at least one conduit configured to communicate the fluid from said internal passageway out of said fluid transportation member, and

a structural reinforcement portion.

33. The fluid transportation member of claim 32, having a first wall thickness associated with said first portion, and a second wall thickness associated with the second portion, said second wall thickness being greater than said first wall thickness, and said structural reinforcement portion being associated with said second wall thickness.

34. The fluid transportation member of claim 33, wherein said second portion has a cross-sectional perimeter, said second wall thickness being substantially constant about said cross-sectional perimeter.

35. The fluid transportation member of claim 32, wherein said at least one conduit is one conduit from a plurality of conduits, each of which is configured to communicate fluid from said internal passageway out of said fluid transportation member; and said structural reinforcement portion includes a plurality of buttresses, each of said plurality of buttresses being disposed between adjacent ones of said plurality of conduits.

36. The fluid transportation member of claim 35, wherein said plurality of buttresses are formed by one of casting, molding, metal injection molding, cold heading, cold forging and powdered metal processing.

37. The fluid transportation member of claim 32, wherein said fluid transportation member is constructed from a metallic material.

38. A poppet for a fuel injector, comprising:

a poppet body defining an internal passageway configured to convey fluid,
said poppet body further defining at least one conduit in fluid communication with
said internal passageway and configured to communicate fluid from said internal
passageway to the exterior of said poppet; and
a structural reinforcement disposed adjacent the junction of said internal
passageway and said at least one conduit.

39. The poppet of claim 38, wherein said poppet body has a cross-sectional perimeter, said
cross-sectional perimeter being of a non-circular shape.

40. The poppet of claim 38, wherein said poppet body has a first wall thickness about said
internal passageway, and a second wall thickness adjacent said at least one conduit, said
second wall thickness being greater than said first wall thickness, and said structural
reinforcement defining at least in part said second wall thickness.

41. The poppet of claim 38, wherein said second wall thickness is substantially constant
about the axial location of said at least one conduit.

42. The poppet of claim 38, wherein said at least one conduit is one conduit from a plurality
of conduits, each of which is configured to communicate fluid from said internal passageway
to the exterior of said poppet; and said structural reinforcement includes a plurality of
buttresses, each of said plurality of buttresses being disposed between adjacent ones of said
plurality of conduits.

43. The assembly of claim 42, wherein said plurality of buttresses are located on an exterior
surface of said poppet body.

44. The poppet of claim 42, wherein said poppet body has a first wall thickness about said internal passageway, and a second wall thickness adjacent said plurality of conduits, said second wall thickness being variable between adjacent ones of said plurality of conduits across each of said plurality of buttresses.

45. The assembly of claim 42, wherein said plurality of buttresses are formed by one of casting, molding, metal injection molding, and powdered metal processing.

46. The assembly of claim 38, wherein said fluid transportation member is constructed from a metallic material.

47. A poppet for a fuel injector, comprising:

 a poppet body defining an internal passageway configured to convey fluid,
 said poppet body further defining at least one conduit in fluid communication with said internal passageway and configured to communicate fluid from said internal passageway to the exterior of said poppet; and

 a means for reinforcing a portion of said poppet body adjacent the junction of said internal passageway and said conduit.

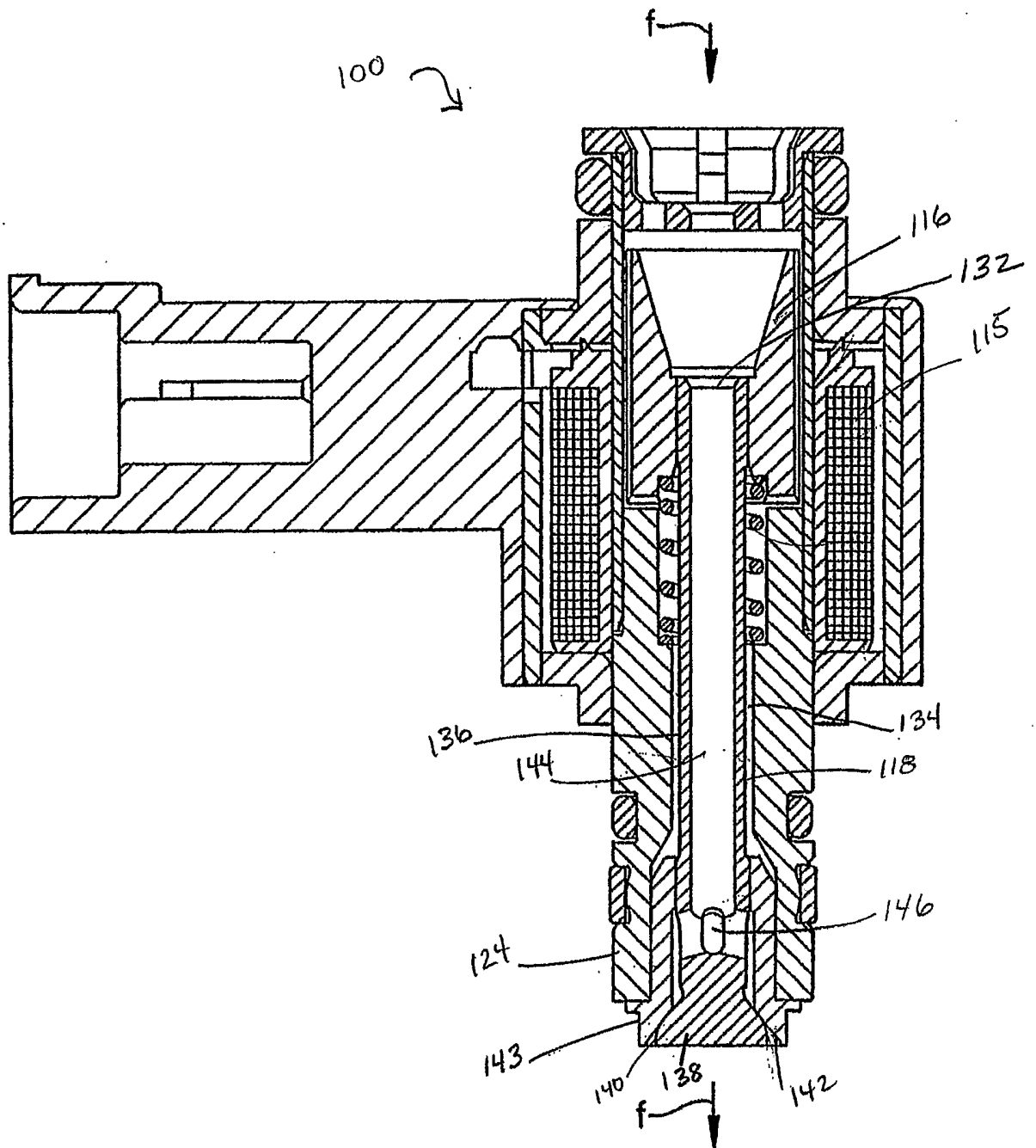

Fig. 1

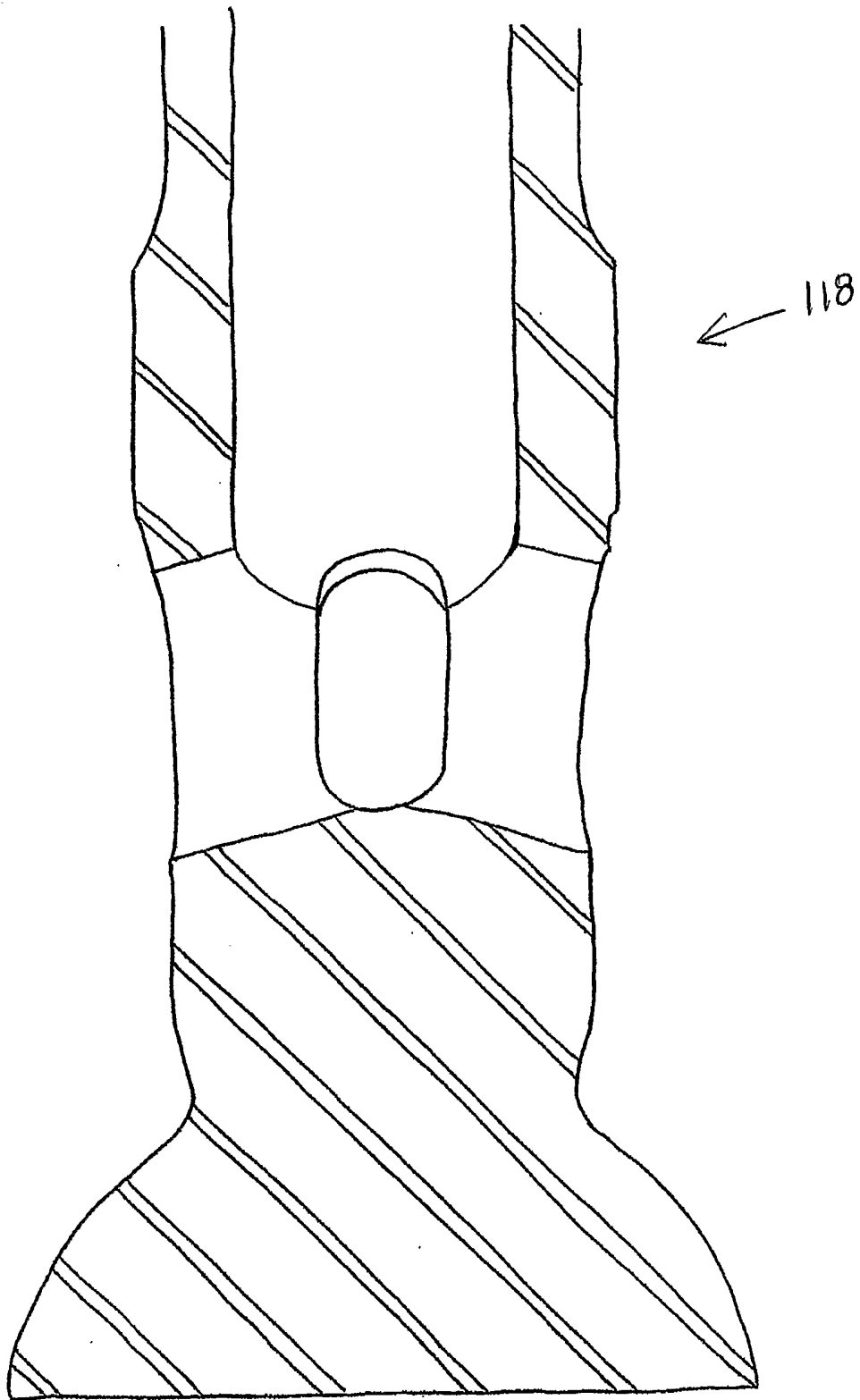

Fig. 2A

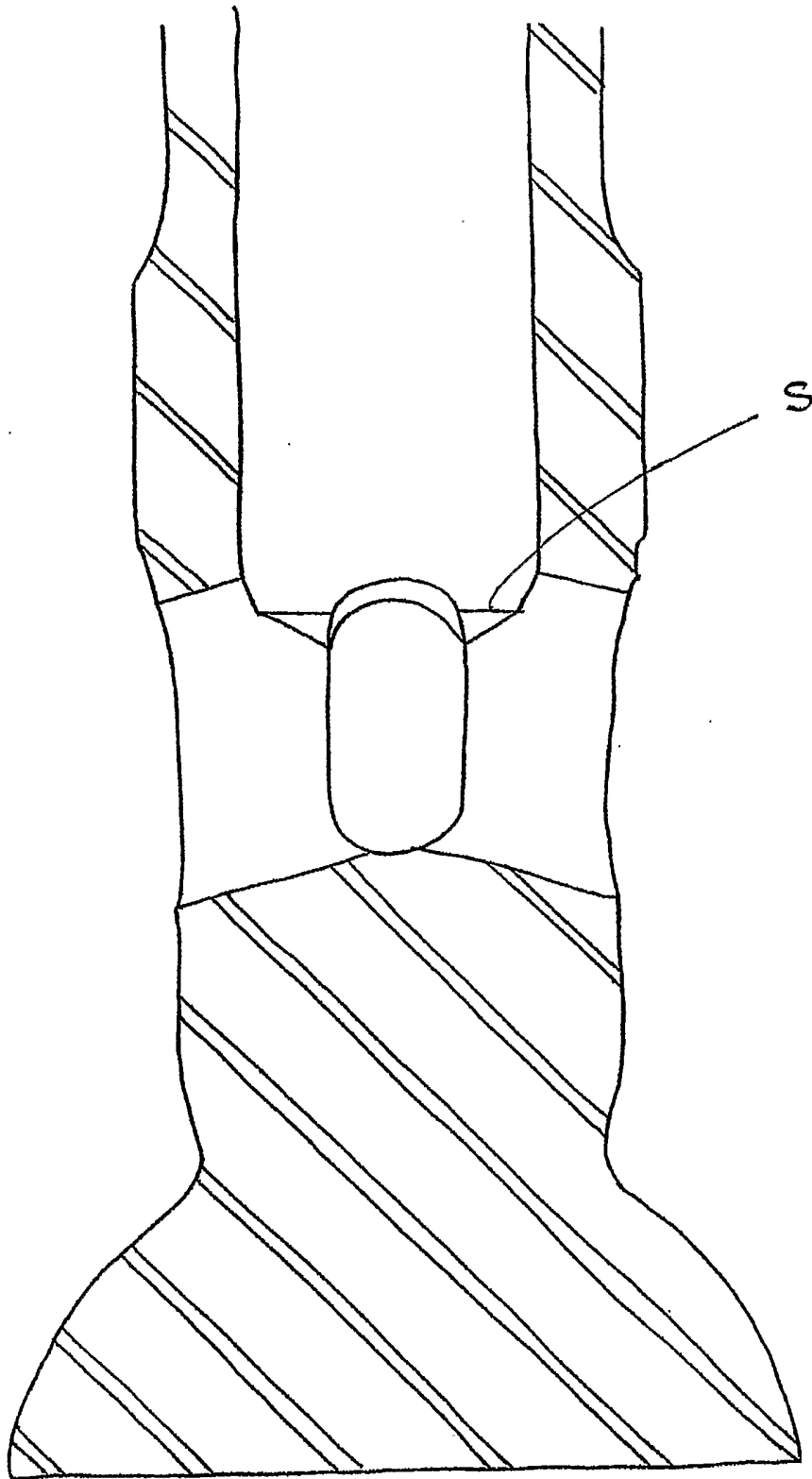

Fig. 2B

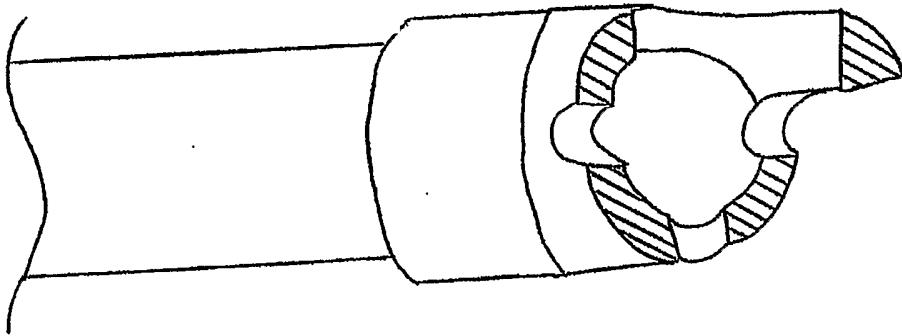

Fig. 3

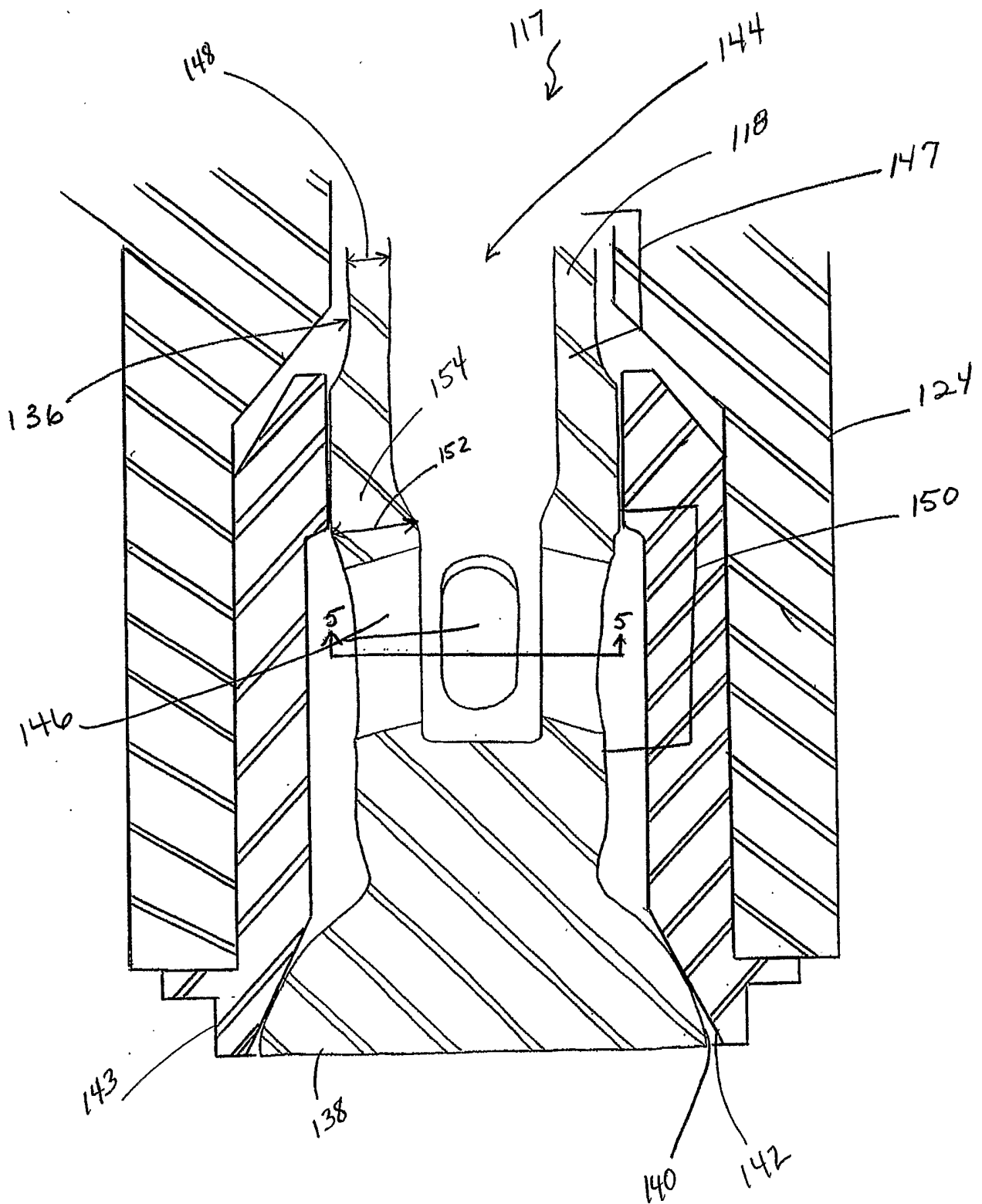

Fig. 4

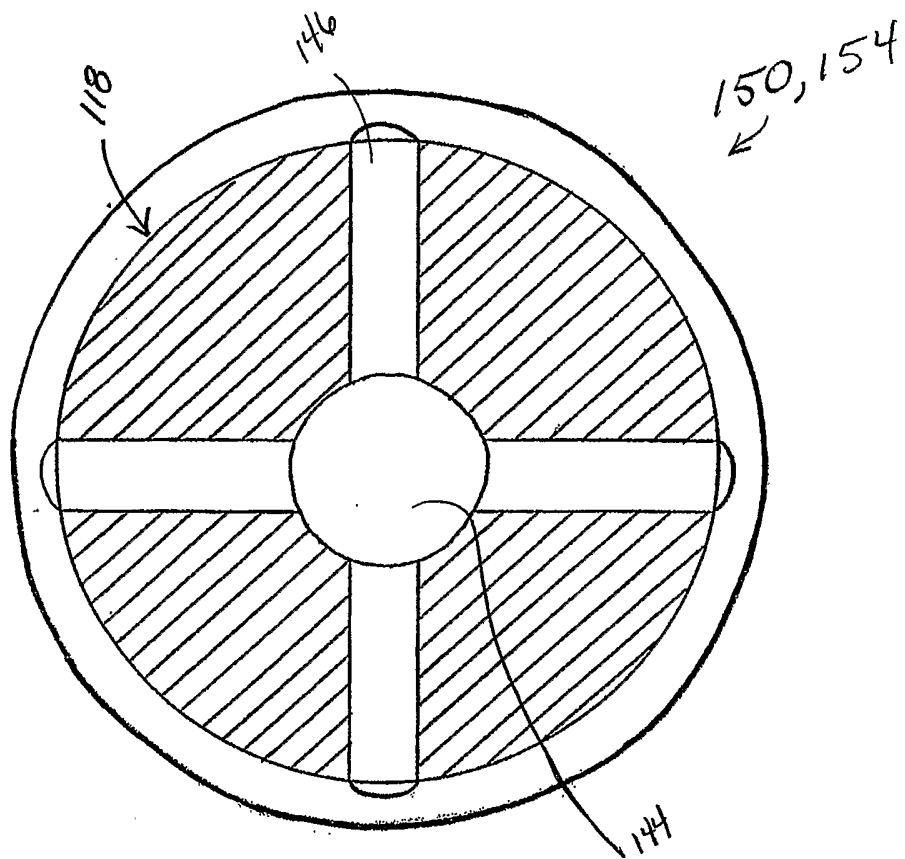

Fig. 5

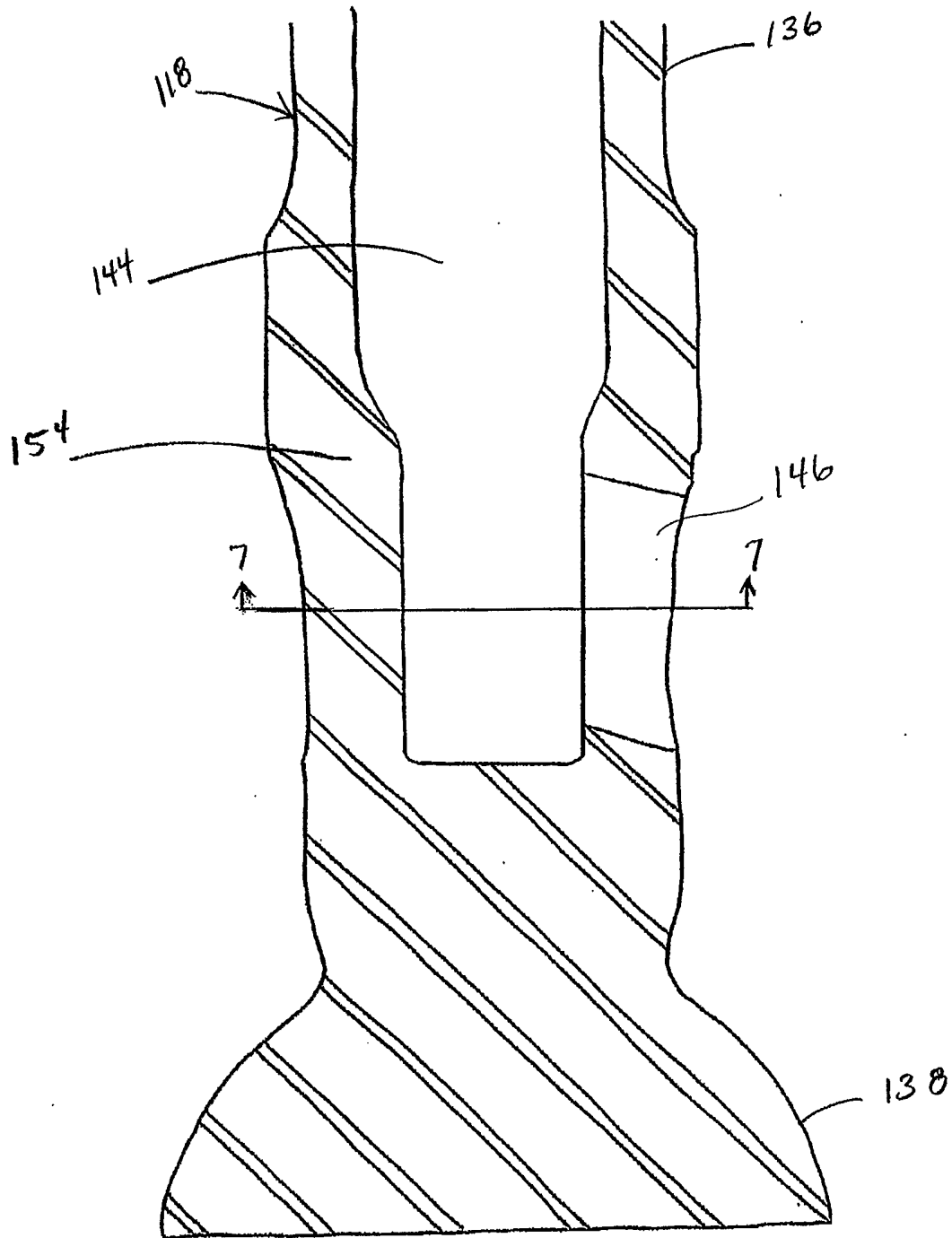

Fig. 6

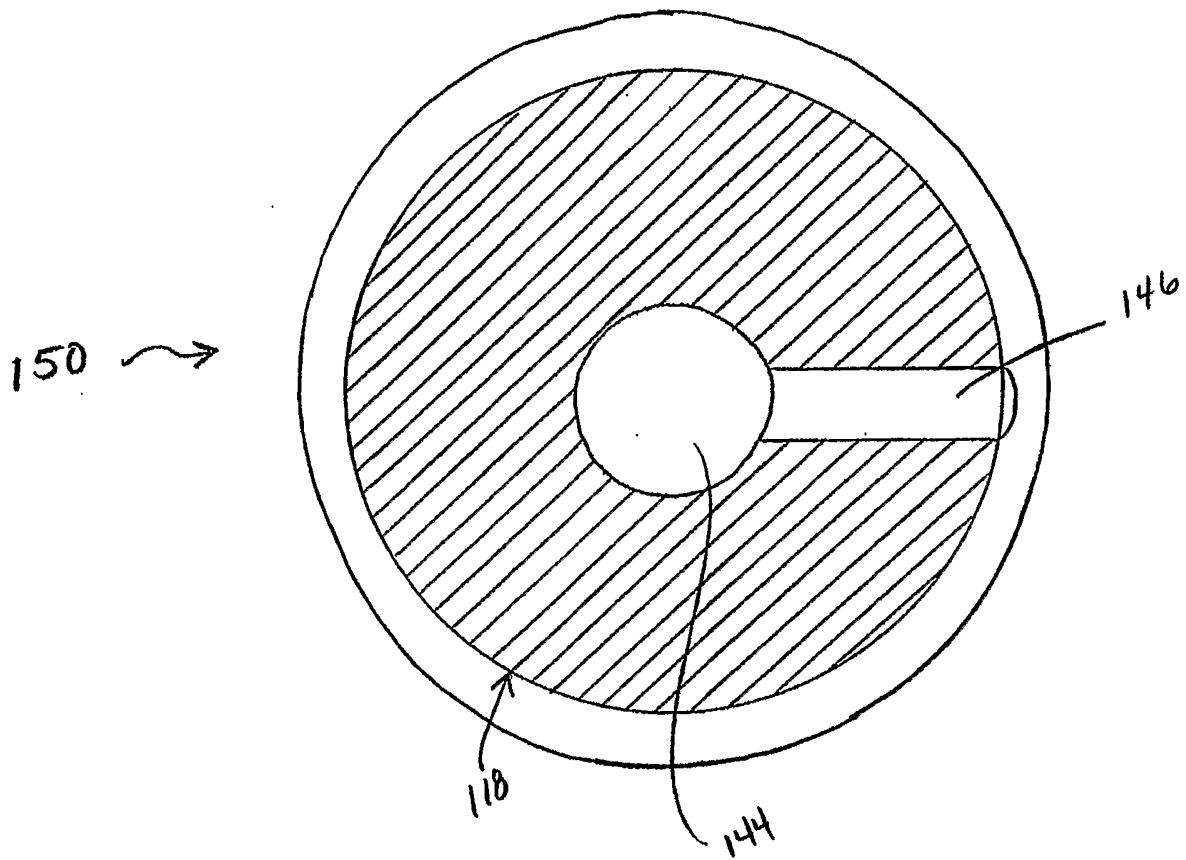

Fig. 7

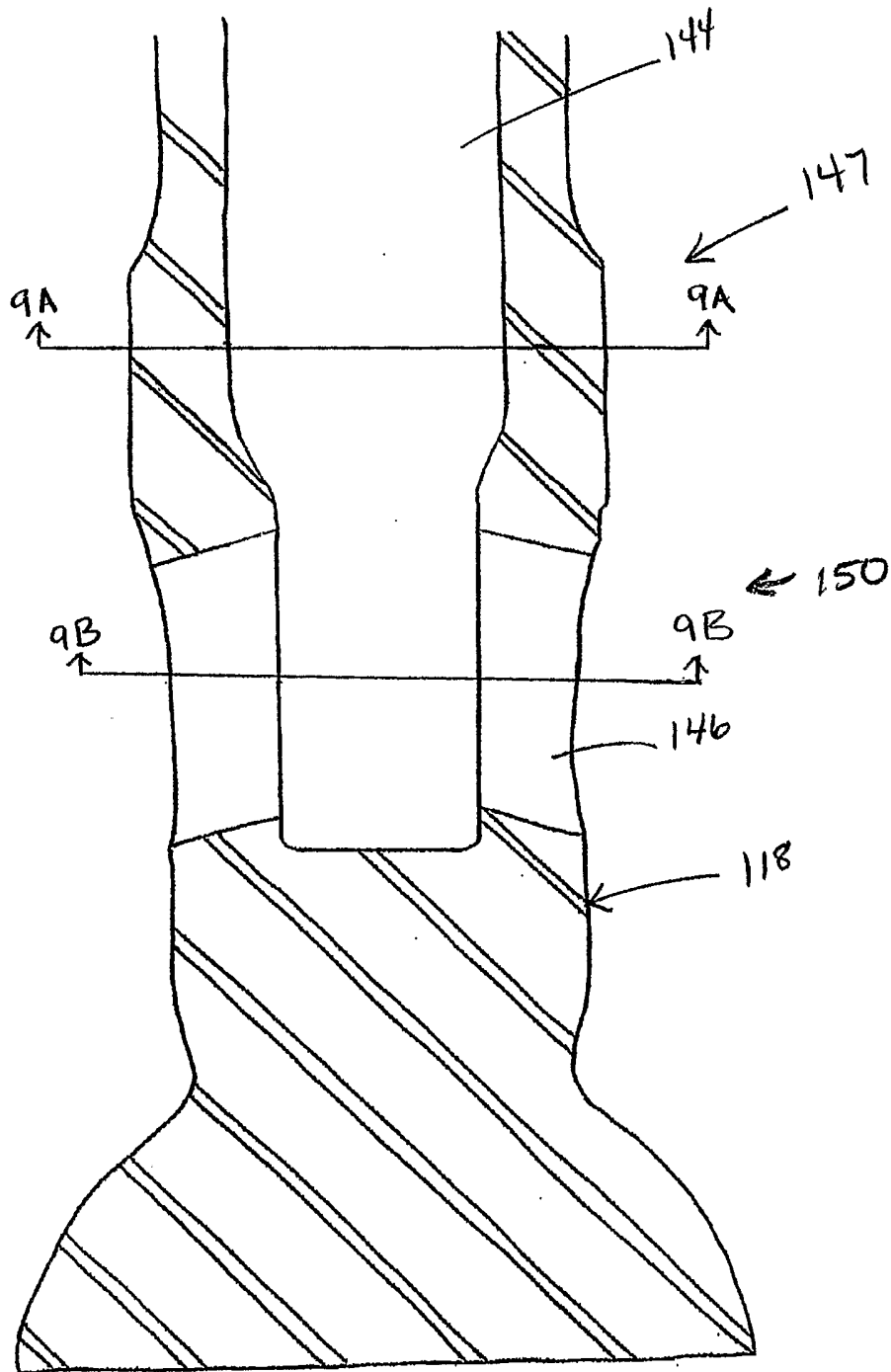

Fig. 8

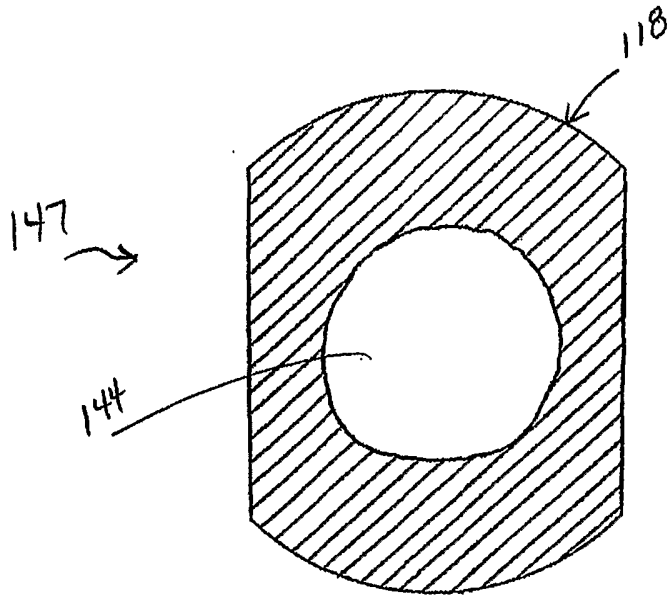

Fig. 9A

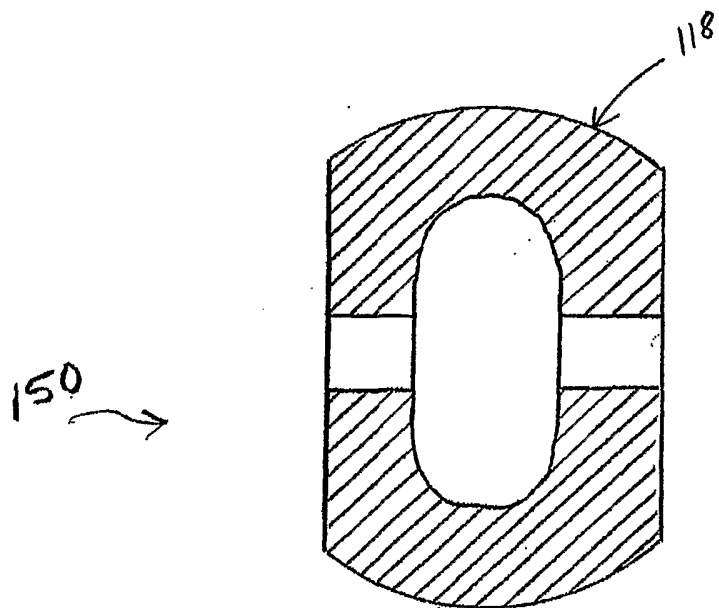

Fig. 9B

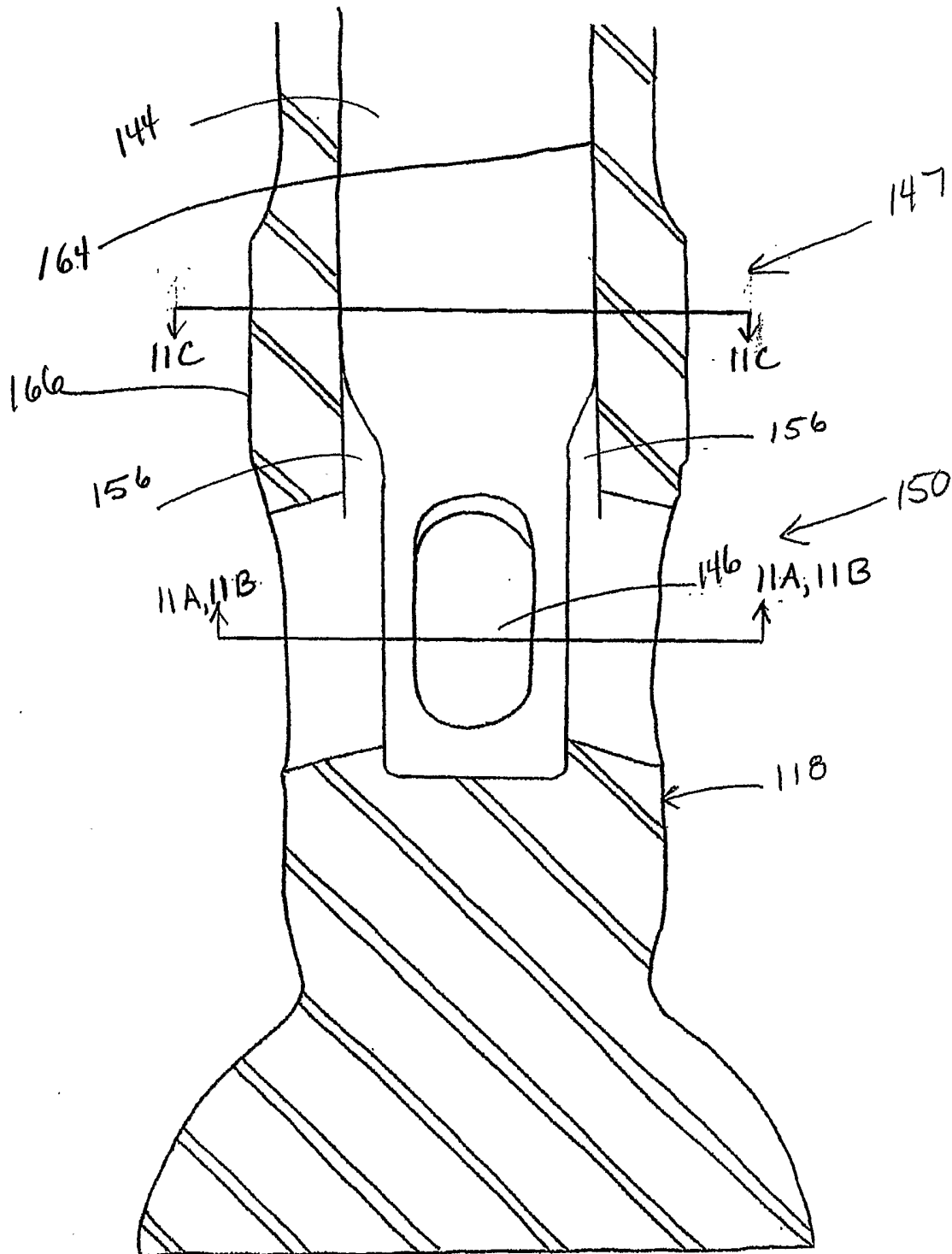

Fig. 10

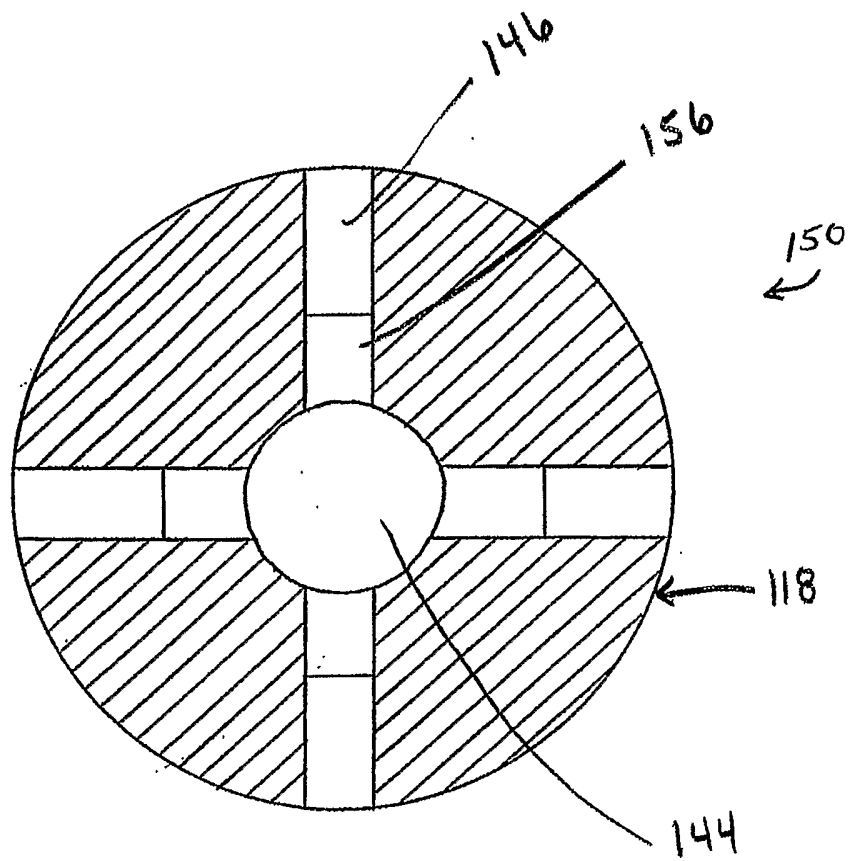

Fig. 11A

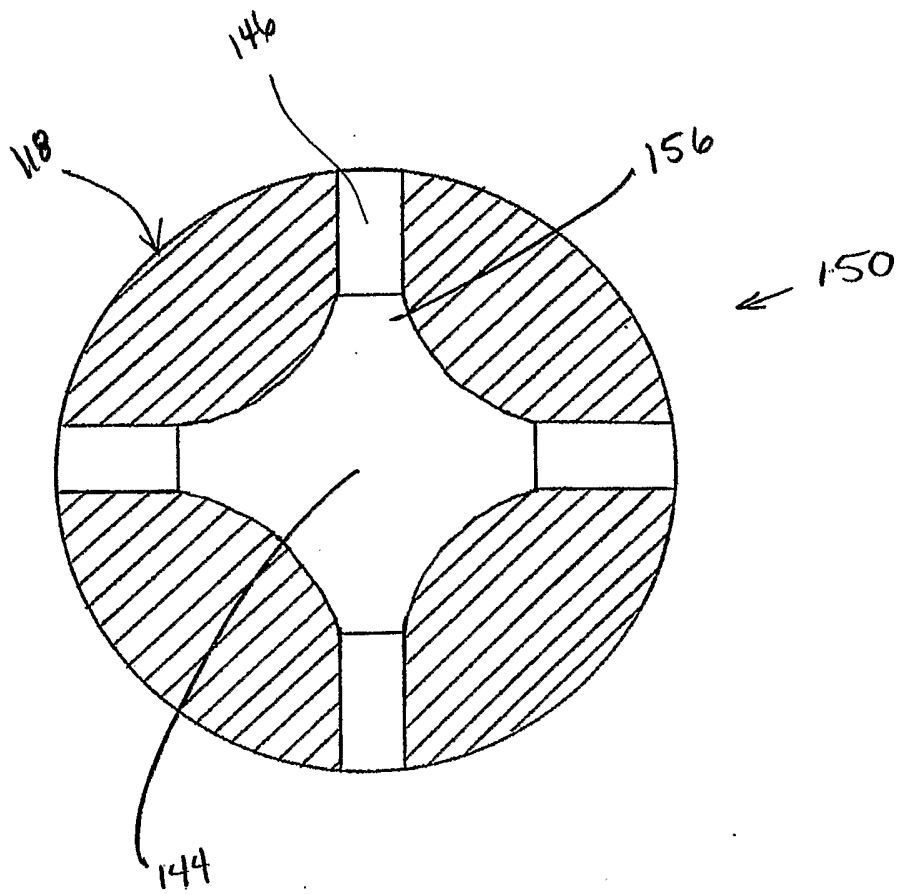

Fig. 11 B

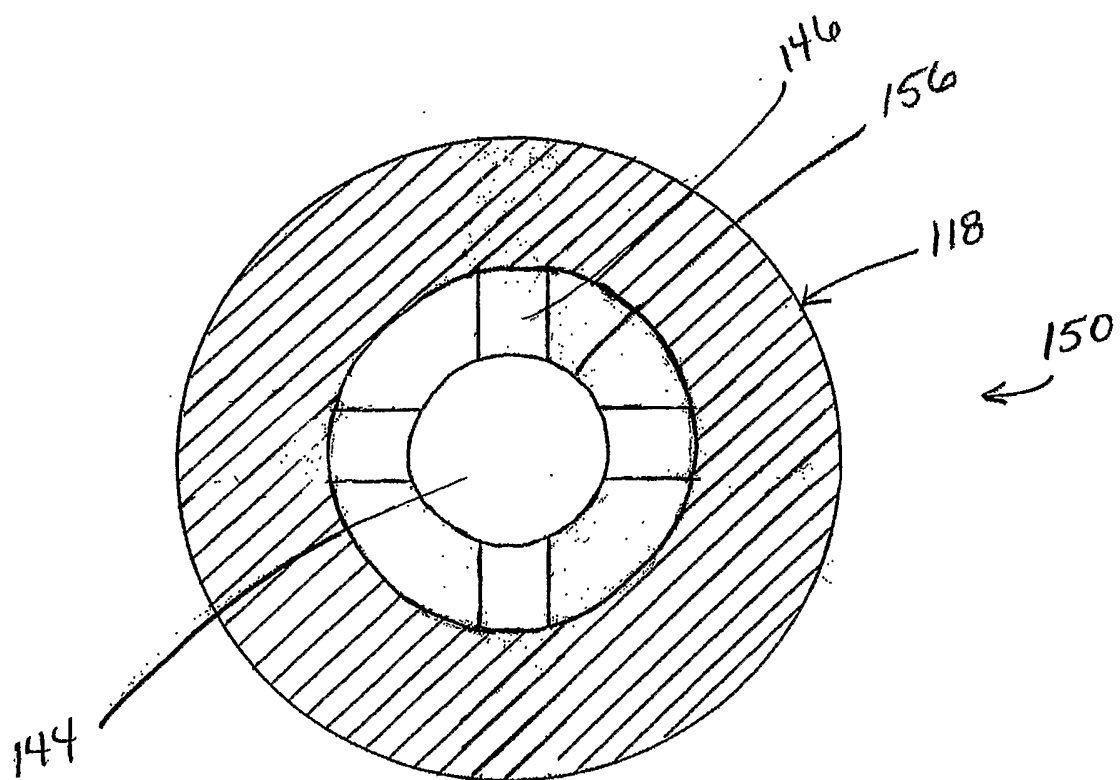

Fig. 11C

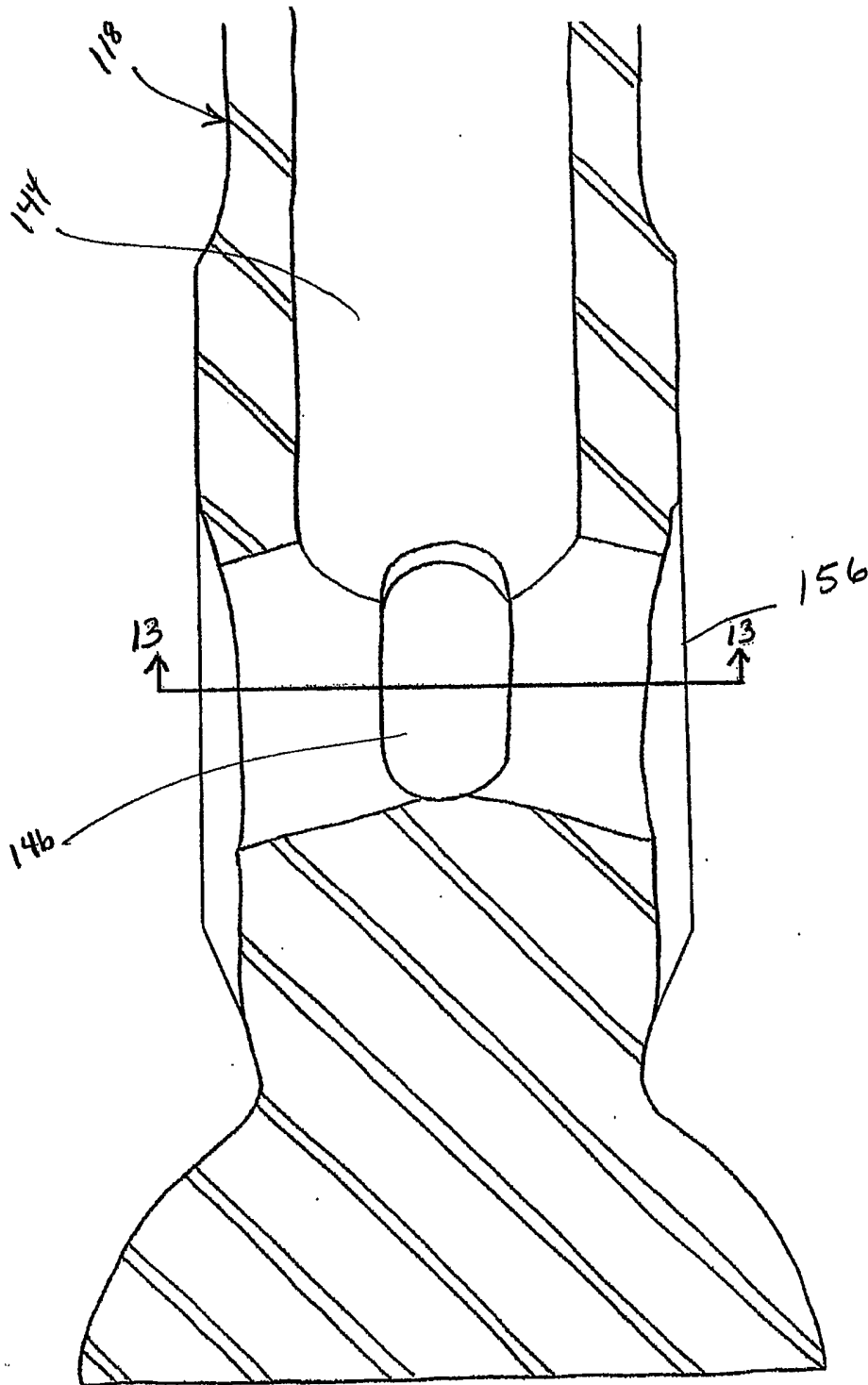

Fig.12

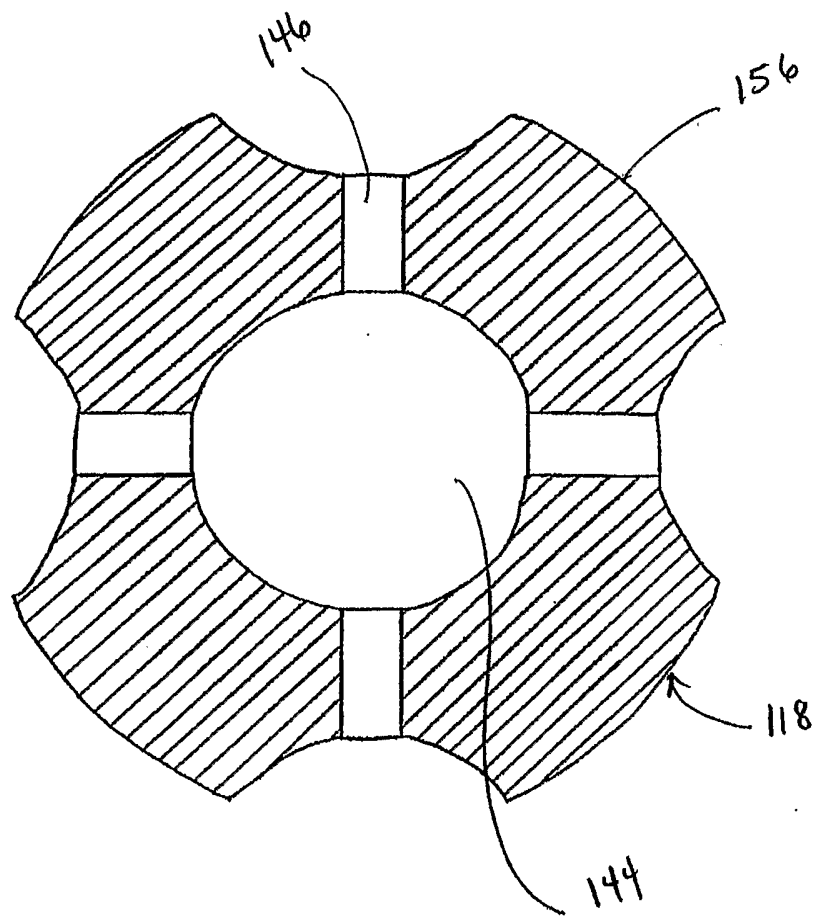

Fig. 13

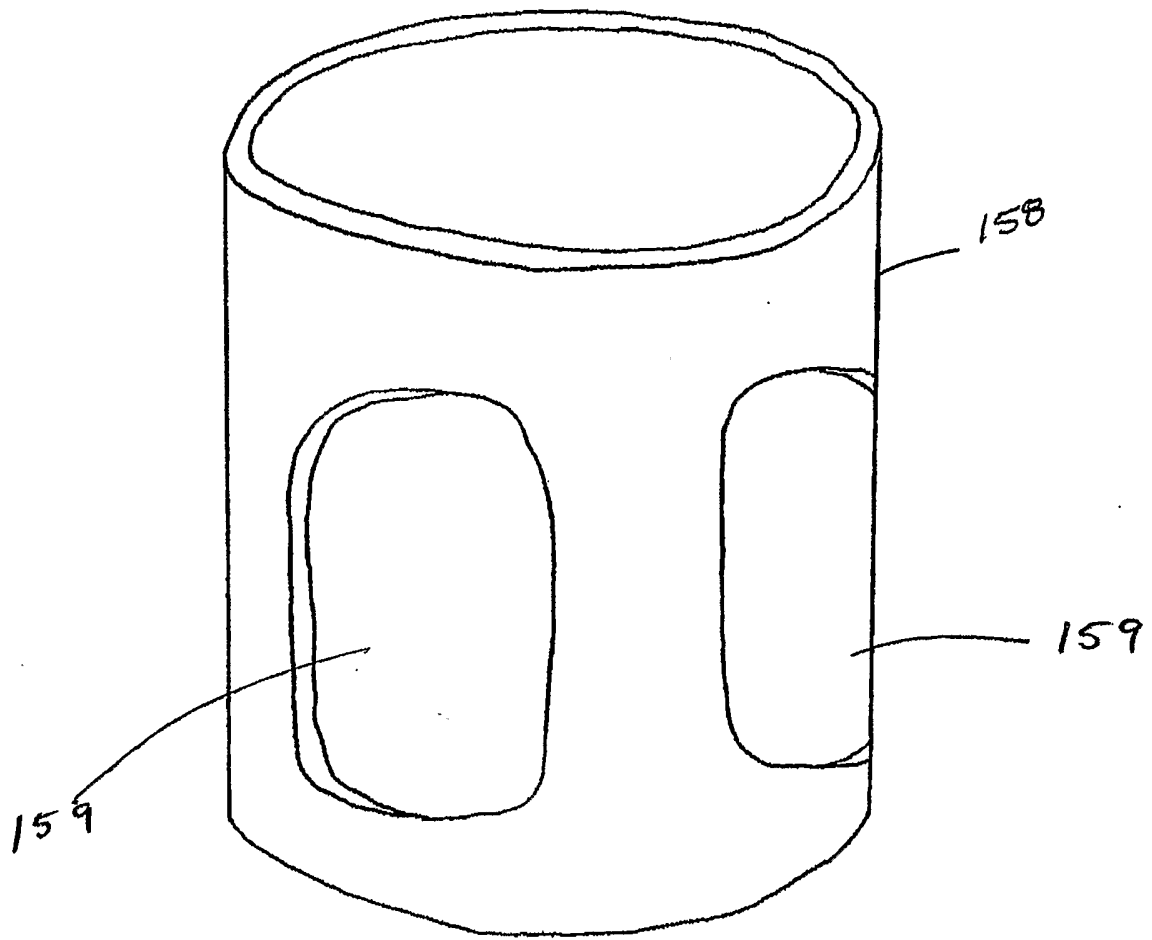

Fig. 14

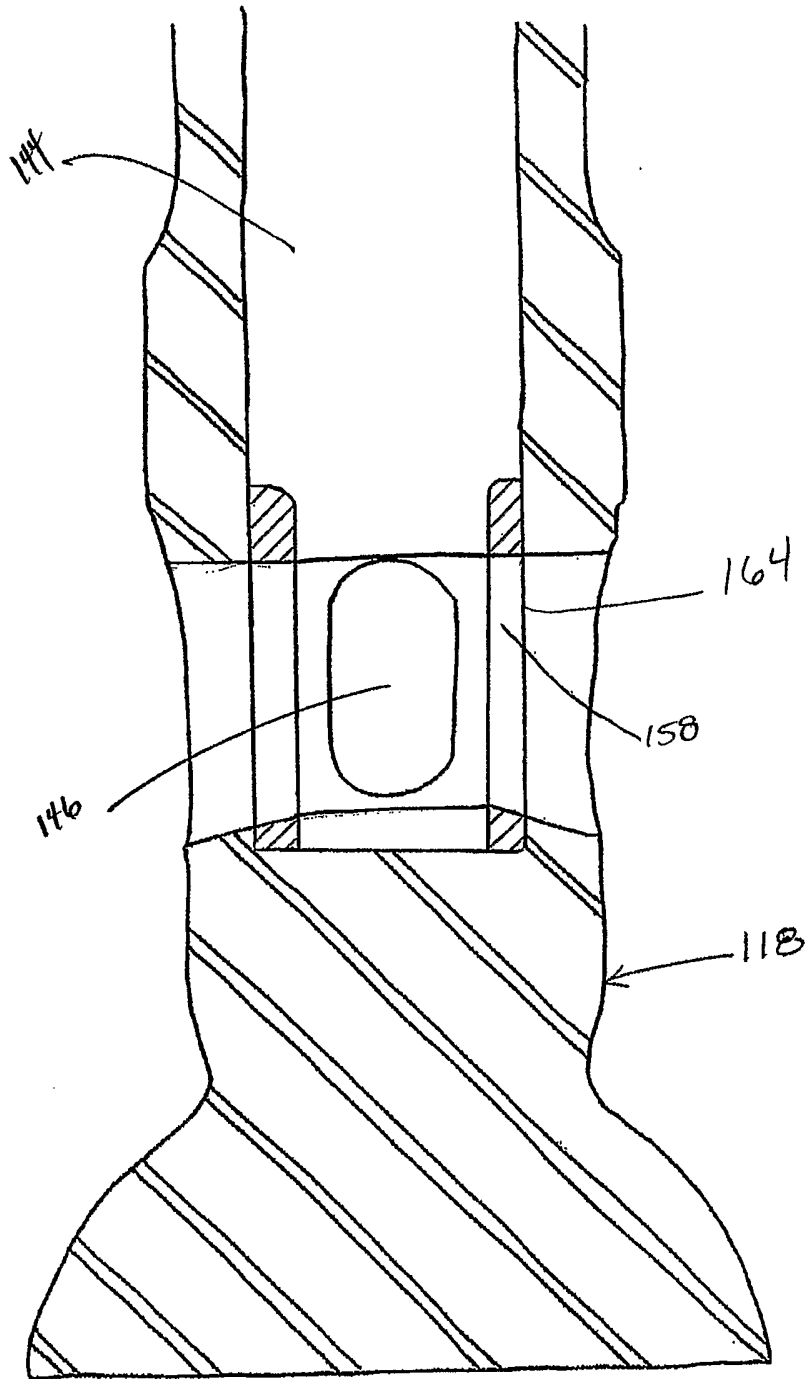

Fig. 15

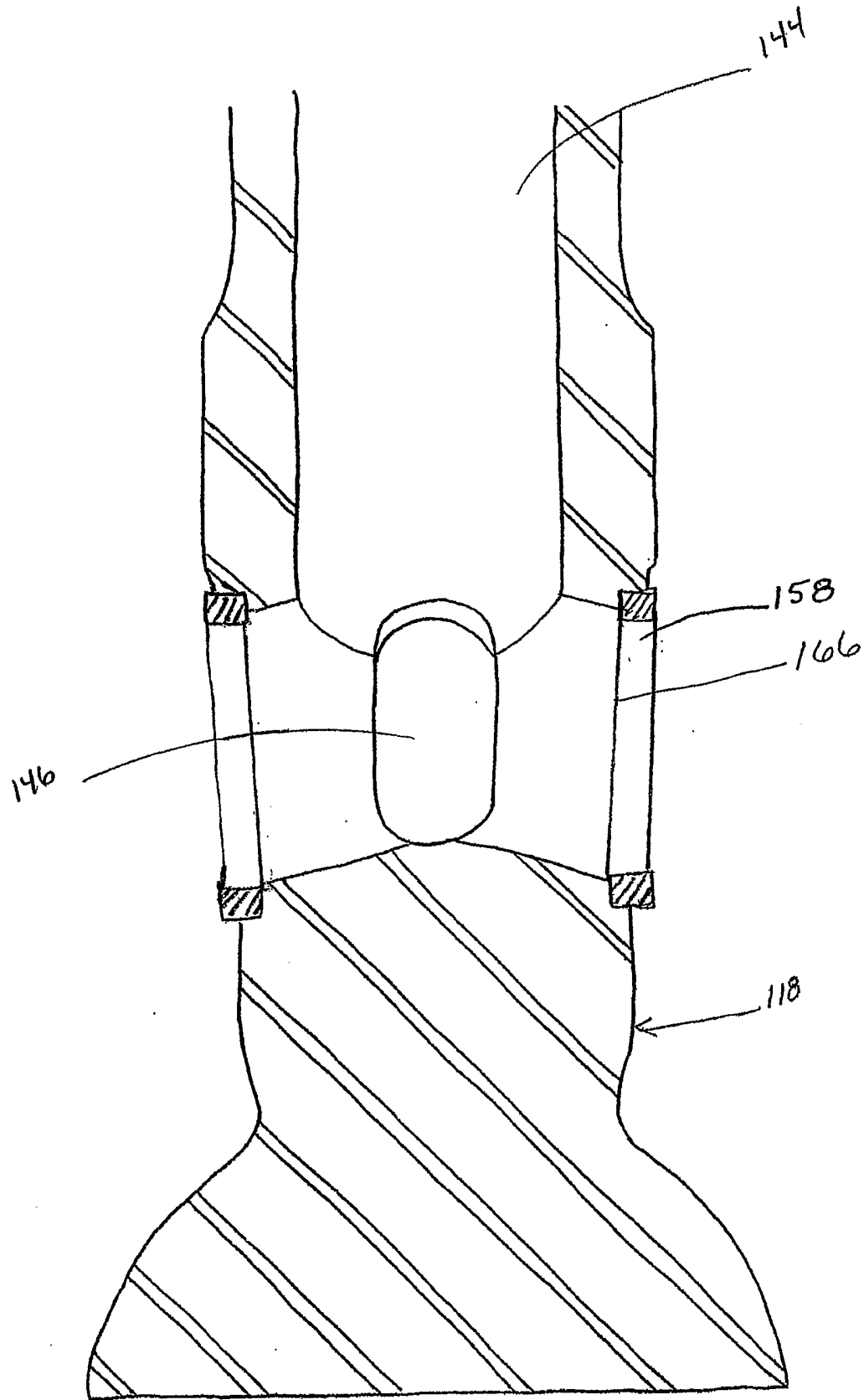

Fig. 16

INTERNATIONAL SEARCH REPORT

International application No.

PCT/US05/44481

A. CLASSIFICATION OF SUBJECT MATTER IPC: F02M 63/00 (2006.01), 61/08 (2006.01) F02M 51/00(2006.01) USPC: 239/533.7,533.2,585.1,585.4,585.5 According to International Patent Classification (IPC) or to both national classification and IPC		
B. FIELDS SEARCHED Minimum documentation searched (classification system followed by classification symbols) U.S. : 239/533.7,533.2,585.1,585.4,585.5,533.3,533.9,533.11,533.12; 123/531,472; 251/129.15 Documentation searched other than minimum documentation to the extent that such documents are included in the fields searched Electronic data base consulted during the international search (name of data base and, where practicable, search terms used)		
C. DOCUMENTS CONSIDERED TO BE RELEVANT		
Category *	Citation of document, with indication, where appropriate, of the relevant passages	Relevant to claim No.
X X --- Y A A A A	US 6,508,416 B1 (MASTRO et al) 21 January 2003 (21.01.2003), see entire document. US 5,983,865 A (YAMASHITA et al) 16 November 1999 (16.11.1999), see entire document. US 5,048,497 (KISHIDA et al) 17 September 1991 (17.09.1991), see entire document. US 6,402,057 B1 (KIMMEL et al) 11 June 2002 (11.06.2002), see entire document. US 6,755,360 B1 (ANDERSON et al) 29 June 2004 (29.06.2004), see entire document. US 6,764,028 B2 (MILLS et al) 20 July 2004 (20.07.2004), see entire document.	1,2,6,7,11-17,20,22-30,32-34,37 1-6,11-19,21-23,32,33,37-41,46,47 ----- 24-30 1-47 1-47 1-47 1-47
<input type="checkbox"/> Further documents are listed in the continuation of Box C. <input type="checkbox"/> See patent family annex.		
* Special categories of cited documents: "A" document defining the general state of the art which is not considered to be of particular relevance "E" earlier application or patent published on or after the international filing date "L" document which may throw doubts on priority claim(s) or which is cited to establish the publication date of another citation or other special reason (as specified) "O" document referring to an oral disclosure, use, exhibition or other means "P" document published prior to the international filing date but later than the priority date claimed	"T" later document published after the international filing date or priority date and not in conflict with the application but cited to understand the principle or theory underlying the invention "X" document of particular relevance; the claimed invention cannot be considered novel or cannot be considered to involve an inventive step when the document is taken alone "Y" document of particular relevance; the claimed invention cannot be considered to involve an inventive step when the document is combined with one or more other such documents, such combination being obvious to a person skilled in the art "&" document member of the same patent family	
Date of the actual completion of the international search 06 April 2006 (06.04.2006)	Date of mailing of the international search report 05 MAY 2006	
Name and mailing address of the ISA/US Mail Stop PCT, Attn: ISA/US Commissioner for Patents P.O. Box 1450 Alexandria, Virginia 22313-1450 Facsimile No. (571) 273-3201	Authorized officer For Dave Scherbel <i>Jugina Libby</i> Telephone No. 703-308-0861	