



(11) **EP 1 585 684 B1**

(12) **EUROPEAN PATENT SPECIFICATION**

(45) Date of publication and mention of the grant of the patent:
22.08.2007 Bulletin 2007/34

(51) Int Cl.:
B65D 49/04 (2006.01) **B65D 49/10** (2006.01)
B65D 55/02 (2006.01) **B65D 41/62** (2006.01)
B65D 55/08 (2006.01) **B65D 49/06** (2006.01)

(21) Application number: **04704267.6**

(86) International application number:
PCT/GB2004/000189

(22) Date of filing: **22.01.2004**

(87) International publication number:
WO 2004/067387 (12.08.2004 Gazette 2004/33)

(54) **LIQUID CONTAINER CLOSURE ASSEMBLY**

VERSCHLUSSZUSAMMENBAU FÜR EINEN FLÜSSIGKEITSBEHÄLTER

ENSEMBLE DE FERMETURE DE RECIPIENT POUR LIQUIDE

(84) Designated Contracting States:
AT BE BG CH CY CZ DE DK EE ES FI FR GB GR HU IE IT LI LU MC NL PT RO SE SI SK TR

• **JOHNSON, Stuart,**
Daniel Montgomery & Son Limited
Glasgow, G66 1ST (GB)

(30) Priority: **25.01.2003 GB 0301818**

(74) Representative: **Perani, Aurelio et al**
Perani Mezzanotte & Partners
Piazza San Babila 5
20122 Milano (IT)

(43) Date of publication of application:
19.10.2005 Bulletin 2005/42

(73) Proprietor: **Guala Closures Patents B.V.**
1012 KK Amsterdam (NL)

(56) References cited:
EP-A- 0 985 607 **WO-A-02/096771**
FR-A- 2 738 802 **US-B1- 6 276 544**

(72) Inventors:
• **THOMSON, David W.,**
Daniel Montgomery & Son Limited
Glasgow G66 1ST (GB)

EP 1 585 684 B1

Note: Within nine months from the publication of the mention of the grant of the European patent, any person may give notice to the European Patent Office of opposition to the European patent granted. Notice of opposition shall be filed in a written reasoned statement. It shall not be deemed to have been filed until the opposition fee has been paid. (Art. 99(1) European Patent Convention).

Description

5 [0001] The present invention relates to a closure assembly adapted to be applied to a mouth of a container (e.g. for liquid), such as a neck of a bottle. The invention particularly, though not exclusively, relates to a tamper-evident snap-on fitment or tamper-evident non-refillable snap-on fitment. A closure assembly according to the preamble of claim 1 is known by, e.g. WO 02/096771.

BACKGROUND TO INVENTION

10 [0002] For various reasons, it may be desirable to ensure that a used container, such as a bottle intended to contain a liquid such as a valuable liquid, (e.g. alcoholic beverages such as spirits), is not re-filled with a replacement quantity of another liquid, the characteristics and quality of which may differ from the original contents. Attempts to provide closures which make such re-filling difficult are not always proof against determined re-filling efforts.

15 [0003] Also, while it is considered advantageous to provide a tamper-indicating means which provides evidence that the bottle and its original contents are intact, if the bottle is resealable with a substitute cap or closure, there may be little to indicate to a purchaser that the bottle has been tampered with and/or refilled and that the contents may be inferior to the original contents.

20 [0004] It has, therefore, been found desirable to provide a closure which cannot be removed without an extreme level of effort, or breakage being caused to the bottle. Such an arrangement is shown, for example, in GB Patent No. 2 274 837 also by the present Applicant, selected merely by way of illustration.

25 [0005] Whilst it is very important that an original closure cannot be removed without visible damage or breakage being caused either to the closure and/or to the bottle, it has been found that a closure that cannot readily be removed will become the target of attempts to re-fill the container by overcoming the feature provided in the closure intended to hinder or prevent such refilling. Therefore, in addition to providing devices to prevent re-filling of bottles, there is a need to provide such devices with further tamper-indicating or "tamper-evident" features which, while not acting in any preventive role, give a clear irremovable and/or irreversible indication that a bottle has been opened since being originally filled with the genuine contents. Such clear indicators have been somewhat lacking in previous closure designs.

[0006] Furthermore, there is a need for simple designs of closure assemblies allowing easy and reliable manufacture, assembly and fitting to bottle necks. Such simplicity has been somewhat lacking in previous closure designs.

30 [0007] Accordingly, it is an object of the present invention to obviate or at least mitigate at least one of the aforementioned problems/disadvantages in the prior art.

[0008] It is also an object of the present invention to provide an improved closure assembly which does not have any parts which are removed upon initial opening and which are liable to be reattached by counterfeiters or the like in a way suggesting that the closure assembly had not previously been opened.

35 [0009] It is a further object of the present invention to provide a closure assembly integrating the functions of tamper indicating means and of non-refillable valve means.

40 [0010] EP 0 985 607 A shows a tamper-evident closure device wherein after the initial opening of the container, as a result of the unscrewing of the cap, an extension is disposed in a position in which it is visible from outside the container providing evidence of opening, but the other end of the extension acting as tamper indication member does not act as a valve member.

SUMMARY OF INVENTION

45 [0011] According to the present invention, there is provided a closure assembly (or tamper-evident device) adapted to be applied to a mouth and neck portion of a container for liquid, according to claim 1.

[0012] The Applicant has named the device of the present invention the "ALUSNAP" (Trade Mark) closure assembly, tamper-evident device, snap-on fitment or non-refillable device.

[0013] In this way a clear indication is given to a person that the closure assembly has been opened and reclosed. The first tamper indication means therefore provides a first visual tamper-evidence means.

50 [0014] Release of the first retaining means allows movement of the first tamper indication means from an initial position to a further position which indicates an initial opening of the closure assembly.

[0015] The closure assembly may also include non-refilling means such as a valve means.

[0016] Preferably the first retaining means comprises a ball carried at a first end of the first tamper indication means and a corresponding socket provided on the baffle.

55 [0017] Preferably the second retaining means comprises a male portion provided on the baffle and a corresponding female portion provided on an inner face of the container closure member.

[0018] The ball and socket may be a releasable friction or interference push-fit with one another. An enlarged radial portion of the male portion may in an initial position co-act with a reduced radial portion of the female portion to retain

EP 1 585 684 B1

the male and female portions together in a releasable push-fit.

[0019] The ball may act as a valve member after initial opening.

[0020] Preferably in an initial unopened position there are provided means for preventing movement of the first tamper indication means in a direction towards the container closure member.

5 [0021] Preferably the movement prevention means comprise a widened second end of the first tamper indication means and an abutting surface of a valve seat body.

[0022] Preferably the first end of the first tamper indication means is provided within the valve seat body and a pouring outlet device or body.

[0023] Preferably in a position after initial opening the ball may act as a valve member.

10 [0024] Preferably the second end of the first tamper indication means comprises a flag member or the like.

[0025] The flag may be suitably coloured to attract the eye and/or may carry information, e.g. marketing or promotional information.

[0026] The valve seat body may be made from a material selected such that in an initial assembly operation the ball may be pushed through an aperture in the valve seat body. This feature is of particular advantage for ease of manufacture.

15 [0027] Preferably the container closure assembly is threadably connected to a/the pouring outlet device by interengaging threaded portions on each.

[0028] The first tamper indication means may be made from a plastics material, e.g. polycarbonate.

[0029] In a modification prior to initial opening, a further valve member may be provided within the socket between the socket and the ball.

20 [0030] Preferably the pouring outlet device includes a pouring lip.

[0031] The closure assembly may comprise a snap-on fitment.

[0032] In one embodiment the closure assembly may comprise a sleeve adapted to lie substantially concentrically with respect to the mouth and provided with means for fixing the sleeve on the container, the closure assembly preferably further comprising a first outer sleeve being a substantially tight fit with the sleeve but rotatable with respect thereto, and a second outer sleeve separate from the first outer sleeve and associated with the container closure member, and wherein there are provided means for spacing apart initially adjacent portions of the first and second outer sleeves upon reclosure of the assembly after an initial opening of the container.

25 [0033] The sleeve and container closure member may be made from suitable plastics materials.

[0034] The spacing means may provide a second visual tamper indication or tamper-evidence means.

30 [0035] Preferably the first outer sleeve has open first and second ends and the second outer sleeve has a first closed end and second open end.

[0036] Preferably the container closure member includes a circumferential groove, which may further provide a circumferential lip portion located below and adjacent to the circumferential groove.

35 [0037] The initially adjacent portions may comprise adjacent respective circumferential edges of the first and second outer sleeves.

[0038] The first and second circumferential edges may prior to initial opening be located in the circumferential groove and may be adjacent one another.

40 [0039] Preferably, during an initial container opening operation, the first circumferential edge expands or rides over the circumferential lip portion and then recoils or retracts, preferably to substantially its original circumferential position so as to become positioned circumferentially behind the circumferential lip portion. Alternatively or additionally during an initial container opening operation, the circumferential lip portion contracts or rides under the first circumferential edge and then recoils or expands preferably to substantially its original circumferential position so as to become positioned circumferentially ahead of the first circumferential edge. This action positions the circumferential lip longitudinally between the first and second circumferential edges in an obstructive manner such that when the container is reclosed by re-applying the closure member, the first and second outer sleeves are spaced apart at least by the circumferential lip portion located therebetween.

45 [0040] The second tamper-evidence means provide that after reclosure the first and second circumferential edges are no longer adjacent but spaced, thus revealing a void or gap between the first and second circumferential edges. This visual indicator evidences that the closure assembly (and container) has been opened and reclosed.

50 [0041] The first circumferential edge of the first outer sleeve may provide a circumferential first beaded portion on the first outer sleeve, and in a same manner the second circumferential edge of the second outer sleeve may provide a circumferential second beaded portion on the second outer sleeve.

[0042] The first and second sleeves may comprise any suitable material, and preferably the material comprises a metal, or metallic based material.

55 [0043] Preferably the metal or metallic based material substantially comprises aluminium or an alloy thereof, and particularly rolled aluminium.

[0044] Advantageously, aluminium provides a good medium for application of printing dyes, inks, paints or the like such that messages, logos, images, names, and/or other information may be carried by the first and second outer

sleeves. A message may, for example, comprise arrows indicating a direction of rotation for opening of the closure assembly.

[0045] The container closure member may be a cap which desirably includes a threaded portion which allows a rotational movement (normally anti-clockwise) of the cap during a container opening operation.

[0046] The closure assembly may include a non-refillable device provided within the pouring outlet device adapted to be secured to the mouth of a container for liquid. The container closure member may be a cap adapted to close an outlet of the pouring outlet device, and the first outer sleeve may be adapted to receive at least part of the pouring outlet device. The outlet may be substantially annular and the cap may carry on an inner facing end an annular seal removably receivable within the annular outlet.

[0047] Preferably the second outer sleeve member is adapted to receive at least part of the cap.

[0048] The cap may be generally received in a tight interference fit to the second outer sleeve, but may be optionally rotatable with respect to the second outer sleeve upon application of sufficient force.

[0049] Desirably the pouring outlet device is made in one piece with the sleeve, e.g. by injection moulding.

[0050] Preferably the non-refillable device further comprises a valve seat body which is at least partially receivable within at least part of the neck portion of the container, and wherein the valve seat body is at least partially surrounded by the sleeve.

[0051] Preferably at least one moveable valve member is provided within the valve seat body.

[0052] Preferably there are provided means for retaining the first outer sleeve in longitudinal relation to the sleeve, e.g. an end of the first outer sleeve at least partially formed over an end of the sleeve.

[0053] Preferably the first and second circumferential edges of the first and second sleeves are before an initial opening of the closure assembly located within the circumferential groove provided on the cap, and are substantially adjacent. This positioning ensures that when the container is initially opened by relative twisting of the cap and sleeve, the second circumferential edge of the second outer sleeve remains within the groove provided on the cap, and the first circumferential edge of the first outer sleeve progressively resiliently may be caused to move circumferentially outward and out of the groove provided on the cap as the cap is removed away from the pouring outlet device and the first portion. Alternatively or additionally the circumferential lip portion may progressively be caused to move circumferentially inward. On removing the contact between the cap and the first circumferential edge of the first outer sleeve, the first circumferential edge retracts to a substantially reduced circumference, (e.g. its original circumference), such that the resulting circumference is less than that of a cap portion which is located below the groove. This cap portion is preferably provided as the circumferential lip on the cap.

[0054] When the cap is re-applied to the pouring outlet device, a stop position is reached when the circumferential lip portion of the cap rests, sits or abuts upon the first circumferential edge of the first outer sleeve, thus preventing the cap being returned to its original unopened starting position. A longitudinal gap or void therefore remains between the first and second outer sleeves thus exposing a circumferential part of the cap, which includes at least part of the circumferential lip which was originally encased or enclosed within the first circumferential edge and an original cap seating surface of the pouring device.

[0055] Advantageously the exposed circumferential part of the cap may be distinctly coloured and/or printed with information, promotional messages or the like.

[0056] The fixing means may comprise first means for fixing the sleeve on the container so as to restrain rotational movement of the sleeve with respect to the neck portion of the container.

[0057] The fixing means may also comprise second means for fixing the sleeve on the container so as to restrict longitudinal movement of the sleeve with respect to the mouth of the container.

[0058] Preferably the second means for fixing the sleeve are in the form of at least one projecting means projecting inwardly of said sleeve, said at least one projecting means being moveable radially of the sleeve in a stiffly resilient manner and being engagable with an outer lip portion of said container.

[0059] Preferably the first outer sleeve fits with the sleeve by means of an interference fit between an outer surface of the sleeve and an inner surface of the first outer sleeve.

[0060] Preferably the cap has thereon a threaded portion, which engages with a corresponding threaded portion on the pouring outlet device.

[0061] It is desired that the first and second outer sleeves are aesthetically pleasing, and as such, it is preferred that the first and second outer sleeves comprise metal foil.

[0062] It is preferred that there are provided means for assembling at least the sleeve and valve seat body together and preferably all parts of the closure assembly together prior to application to the container. In such latter case, the closure assembly may be referred to as a "one piece fitment".

[0063] Preferably the projecting means are provided on an inner wall of the sleeve to resiliently engage the neck portion of the container.

[0064] Preferably the sleeve contains one or more circumferential apertures around the sleeve, which are defined between axially extending portions of the sleeve. The/each projecting means may be provided adjacent to an edge of

one of the apertures. It is preferred that each projecting means is positioned on a lower circumferential edge of one of the apertures.

[0065] Typically the pouring outlet device comprises a circumferentially extending pouring lip.

[0066] Conveniently said baffle is provided with a circumferentially extending brim which is positioned on the lower outer edge of said baffle. The brim assists in deterring illicit refilling activities.

[0067] The sleeve is further conveniently provided with a plurality of ribs or ridges formed on an inner surface thereof, preferably arranged circumferentially around the sleeve and having their long axes arranged substantially axially to said sleeve.

[0068] These ribs or ridges, in use, may co-act with raised pips, ridges or the line, on an outer surface of the container (e.g. a "glass finish" of the bottle) to seek to prevent undesired rotational movement of the sleeve.

[0069] The valve seat body may comprise a tubular portion, a free end portion of which provides a valve seat adapted to be contacted in a sealing manner by a valve member captive in said tubular portion.

[0070] The valve seat is preferably a circumferentially extending flange, which extends radially inwardly of the tubular portion. In one embodiment such a valve seat is positioned at one end of the tubular portion, and that end of the tubular portion is closed except for a circular aperture.

[0071] It will be understood that the tubular portion is adapted to be received substantially within the mouth portion of the container.

[0072] The tubular portion may further comprise at least one engagement means on an outer surface thereof to engage an inner surface of the container in an interference fashion. The engagement means are preferably radially extending circumferential ribs.

[0073] At or near to an end of the tubular portion distant from the valve seat is provided a substantially concentric further tubular portion of greater diameter than the tubular portion, and an inner surface of the further tubular portion is connected to an outer surface of the tubular portion by one or more webs.

[0074] It is preferred that a first end of the further tubular portion is connected to an outer surface of the tubular portion by an annular flange.

[0075] Thus, in one embodiment of the present invention, such construction provides a circumferential trough defined between the outer surface of the tubular portion and the inner surface of the further tubular portion with the flange forming a trough floor. The trough is divided into smaller arc-shaped troughs by the webs.

[0076] Such a trough helps prevent insertion of objects into the container through the closure assembly.

[0077] Preferably a second end of the further tubular portion is arranged substantially flush with an end of the tubular portion distant from the valve seat.

[0078] In use the tubular portion forms an inner sleeve of the assembled closure assembly.

[0079] Advantageously, an outer surface of the further tubular portion interference interacts with an inner surface of the sleeve and/or pouring outlet device.

[0080] Conveniently, a radially extending circumferential rim is located on an outer edge of an end of the further tubular portion, which, in an assembled closure assembly is seated against a lower surface of a radially extending circumferential rim provided on an inner surface of the sleeve.

[0081] According to a second aspect of the present invention there is provided a closure assembly (or tamper-evident device) adapted to be applied to a mouth and neck portion of a container for liquid, the assembly comprising:

- a first tamper indication means, and
- a container closure member, and wherein prior to initial opening the first tamper indication means and the closure member are retained in association with one another by push-fit or interference fit retaining means, and wherein further
- initial opening causes release of the push-fit or interference fit retaining means.

[0082] In other words, initial opening causes release of the first tamper indication means from the container closure member.

[0083] The push-fit or interference fit retaining means may comprise first retaining means for retaining the first tamper indication means in association with a baffle and second retaining means for retaining the baffle in association with the container closure member.

[0084] Preferably release of the retaining means may cause the first tamper indication means to move from a first position to a second position. Such movement is indicative of initial opening. Preferably in said second position, the first tamper indication means is visible within the container, and preferably hangs in the container.

[0085] According to a third aspect of the present invention there is provided a closure assembly (or tamper-evident device) according to claim 1 wherein prior to initial opening the first member and the container closure member are retained in association with one another by retaining means, and wherein further initial opening of the closure assembly causes release of the retaining means which causes the first member thereafter

to act as a valve member.

[0086] The first member may comprise a first tamper indication member, e.g. a first visual tamper-evidence means. The retaining means may comprise a releasable push/ clip/interference fit retaining means.

5 **[0087]** In one implementation the retaining means may comprise first retaining means for retaining the first member in association with a baffle and second retaining means for retaining the baffle in association with the container closure member.

[0088] In an alternative implementation the retaining means may comprise first retaining means for retaining the first member in association with the container closure member.

[0089] In either case the container closure member may comprise a cap and a retaining member.

10 **[0090]** Preferably the retaining member is securely fixed to the cap by lock means, e.g. co-acting ribs and grooves on the retaining member and the cap.

[0091] Prior to initial opening the first member may be retained in association with the baffle by the first retaining means, and the baffle may be retained in association with the container closure member by the second retaining means, and wherein further

15 initial opening of the closure assembly may cause in sequence release of the first retaining means and release of the second retaining means.

[0092] Release of the retaining means may cause or allow movement of the first member from an initial position to a further position which indicates an initial opening of the closure assembly.

[0093] Said movement may comprise the first member dropping from said initial position to said further position.

20 **[0094]** According to a fourth embodiment of the present invention there is provided a container including a closure assembly according to the present invention.

[0095] The container is preferably a container for liquid.

[0096] The container may be a bottle, e.g. a glass bottle, and may be adapted for containment of liquid, such as alcoholic drinks or beverages, e.g. spirits such as vodka, whisky, brandy, gin or the like.

25 **[0097]** According to a fifth embodiment of the present invention there is provided a combination of a container and a closure assembly according to the present invention.

[0098] According to a sixth embodiment of the present invention there is provided an alcoholic drinks product comprising an alcoholic substance packaged in the combination according to the fourth embodiment of the present invention.

30 **[0099]** According to a seventh embodiment of the present invention there is provided a method of manufacturing a closure. assembly according to the present invention comprising the steps of:

(a) providing an outer sleeve member;

(b) providing a pouring outlet device and a sleeve adapted to be secured to a mouth and neck portion of a container for liquid and a container closure member releasably securable to the pouring outlet device and/or sleeve;

35 (c) disposing the pouring outlet device, sleeve and container closure member at least partly within the outer sleeve member;

(d) forming the outer sleeve member into a first outer sleeve and a separate second outer sleeve.

[0100] This method is particularly advantageous in mass production.

40 **[0101]** Preferably step (d) is carried out using a first cutting tool such as a blade of a machine tool.

[0102] Preferably step (d) comprises:

forming a cut around a portion of the outer sleeve member so as to form adjacent first and second circumferential edges on the first and second outer sleeves.

45 **[0103]** Advantageously, the first and second edges are formed in a groove carried on the container closure member.

[0104] Advantageously the first and second circumferential edges are of reduced diameter compared to at least adjacent portions of the first or second outer sleeve, respectively.

[0105] Preferably after step (c) the method also comprises the step of:

50 (e) forming an end of the first outer sleeve over an end of the sleeve so as to retain the first outer sleeve and the sleeve in longitudinal relation.

[0106] Preferably step (e) is carried out using a second cutting tool such as a further blade of a machine tool.

55 **[0107]** Steps (d) and (e) may be undertaken substantially simultaneously.

[0108] The closure assembly so formed may comprise a unitary assembly for snap-on application to a mouth and neck portion of a container.

[0109] According to an eighth embodiment of the present invention there is provided a method of bottling comprising:

- (a) providing a closure assembly according to the present invention;
- (b) providing a bottle;
- (c) filling the bottle with a liquid;
- (d) closing the bottle by applying the closure assembly to a mouth and neck of the bottle.

5

[0110] According to a ninth embodiment of the present invention there is provided a method of manufacturing a closure assembly according to the present invention, wherein the method comprises the steps of:

10

- (a) providing a valve seat body and a valve member; and
- (b) assembling the valve seat body and valve member together by pushing the valve member through an aperture in the valve seat body, a width of the valve member being greater than a width of the aperture in the valve seat body.

15

[0111] According to a tenth embodiment of the present invention there is provided a closure assembly (or tamper-evident device) according to the present invention wherein prior to initial opening the first member and the container closure member are retained in association with one another by retaining means, and wherein further initial opening of the closure assembly causes release of the retaining means which causes the first member thereafter to act as a first tamper evidence or indication means or member.

BRIEF DESCRIPTION OF DRAWINGS

20

[0112] Embodiments of the present invention will now be described by way of example only, and with reference to the accompanying drawings, which are:

25

Figure 1 (a) a cross-sectional side view of a closure assembly according to a first embodiment of the present invention prior to an initial opening operation;

Figure 1(b) a cross-sectional side view of the closure assembly of Figure 1(a) during an initial opening operation;

30

Figure 1(c) a cross-sectional side view of the closure assembly of Figure 1(a) after an initial (or subsequent) opening operation;

Figure 1(d) a cross-sectional side view of the closure assembly of Figure 1(a) after a reclosure operation;

35

Figure 2 a further cross-sectional side view of the closure assembly of Figure 1(a) prior to an initial opening operation;

Figure 3 an exploded perspective view of component parts of the closure assembly of Figure 1(a).

40

Figures 4(a) to (e) a sequence of cross-sectional side views of a closure assembly according to a second embodiment of the present invention:

45

- (a) unopened;
- (b) during first opening;
- (c) opened;
- (d) during pouring; and
- (e) reclosed; and

50

Figures 5(a) to (e) a sequence of cross-sectional side views of a closure assembly according to a third embodiment of the present invention:

55

- (a) unopened;
- (b) during first opening;
- (c) opened;
- (d) during pouring; and
- (e) reclosed.

DETAILED DESCRIPTION OF DRAWINGS

[0113] Referring to Figures 1(a) to 3, there is shown a closure assembly (or tamper-evident device), generally designated 5, according to a first embodiment of the present invention. The closure assembly 5 is adapted to be applied to a mouth and neck portion of a container for liquid (partly shown in outline in Figure 2). The closure assembly 5 comprises: a first member or tamper indication means 10; a baffle 15; and a container closure member 20, wherein prior to initial opening the first tamper indication means 10 is retained in association with the baffle 15 by first retaining means (first joint) 25, and the baffle 15 is retained in association with the container closure member 20 by second retaining means (second joint or clip) 30 (Figure 1(a)), and wherein further initial opening of the closure assembly 5 causes in sequence release of the first retaining means 25 (Figure 1(b)) and then the second retaining means 30 (Figure 1(c)).

[0114] In other words, a release force of the first retaining means 25 is less than a release force of the second retaining means 20.

[0115] Release of the first retaining means 25 allows movement of the first tamper indication means 10 from an initial position to a further position which indicates an initial opening of the closure assembly 5. The first tamper indication means 10 may therefore be referred to as a drop-down flag.

[0116] The closure assembly 5 also includes non-refilling means, such as valve means, as will hereinafter be described in greater detail.

[0117] The first retaining means 25 comprises a ball or ball like member 35 carried at a first end 40 of the first tamper indication means 10 and a corresponding socket 45 is provided on the baffle 15.

[0118] The second retaining means 30 comprises a male portion 50 provided on the baffle 15 and a corresponding female portion 55 provided on an inner face 60 of the container closure member 20.

[0119] The ball 35 and socket 45 are a releasable friction or interference push-fit with one another. An enlarged radial portion 65 of the male portion 50 in an initial position co-acts with a reduced radial portion 70 of the female portion 55 to retain the male and female portion 50,55 together in a releasable push-fit.

[0120] The ball 35 acts as a valve member 75 after initial opening.

[0121] In an initial unopened position there are provided means for preventing movement of the first tamper indication means 10 in a direction towards the container closure member 20. The movement prevention means comprise a widened second end 80 of the first tamper indication means 10 and an abutting surface 85 of a valve seat body 90. The first end 40 of the first tamper indication means 10 is provided within the valve seat body 90 and a pouring outlet device or body 95.

[0122] In a position after initial opening, the ball 35 having dropped from socket 45, acts as the valve member 75.

[0123] The second end 80 of the first tamper indication means 10 comprises a flag member 100 or the like. The flag 100 can be suitably coloured to attract the eye and/or may carry information, e.g. marketing or promotional information.

[0124] The valve seat body 90 can be made from a material selected such that in an initial assembly operation the ball 35 can be pushed through an aperture 105 in the valve seat body 90. This feature is of particular advantage for ease of manufacture.

[0125] The container closure assembly 20 is threadably connected to a/the pouring outlet device 95 by interengaging and co-acting threaded portions on each 110,115.

[0126] The first tamper indication means 10 can be made from a plastics material, e.g. polycarbonate.

[0127] In a modification prior to initial opening a further valve member (not shown) can be provided within the socket 45 between the socket 45 and the ball 35.

[0128] As can be seen in Figure 3, the pouring outlet device 75 includes a pouring lip 96.

[0129] The closure assembly 5 comprises a sleeve 220 adapted to lie substantially concentrically with respect to mouth 210 and provided with means for fixing the sleeve 220 on the container 215. The closure assembly 5 further comprises a first outer sleeve 225 being a substantially tight interference fit with the sleeve 220 but rotatable with respect thereto upon application of sufficient rotational force. The closure assembly 5 also comprises a second outer sleeve 230 separate from the first outer sleeve 225 and associated with a container closure member or cap 20. Between the initially unopened first and second outer sleeves 225, 230 there is provided a circumferentially extending cut line 231 (see Figure 1(a)) formed as will hereinafter be described. The cut line 231 extends 360° around the closure assembly 5 and separates the first and second outer sleeve 225, 230. The cut line 231 may be unperceivable or at least almost unperceivable by the naked eye.

[0130] There are also provided means for spacing apart initially adjacent portions of the first and second outer sleeves 225, 230 upon reclosure of the closure assembly 5 after an initial opening of the container 215, as will hereinafter be described in greater detail, which spacing means comprise second tamper indication or tamper-evident means.

[0131] The first outer sleeve 225 has open first and second ends 240, 245, and the second outer sleeve 230 has a first closed end 250 and a second open end 255.

[0132] The cap 20 includes a circumferential groove 260, and further provides a circumferential lip portion 265 located below and adjacent to the circumferential groove 260.

[0133] The initially adjacent portions comprise initially adjacent respective circumferential edges 270, 275 of the first

and second outer sleeves 225, 230. The first and second circumferential edges 270, 275 are prior to initial opening located in the circumferential groove 260 and are substantially adjacent one another.

5 [0134] During an initial container opening operation, the first circumferential edge 270 expands or rides over the circumferential lip portion 265 and then recoils or retracts to substantially its original circumferential position so as to become positioned radially behind the circumferential lip portion 265. Alternatively or additionally during an initial container opening operation, the circumferential lip portion 265 contracts or rides under the first circumferential edge 270 and then recoils or expands to substantially its original circumferential position so as to become positioned radially ahead of the first circumferential edge 270. This action or these actions position the circumferential lip portion 265 longitudinally between the first and second circumferential edges 270, 275 in an obstructive manner such that when the container 215 is reclosed by re-applying the cap 20, the first and second outer sleeves 225, 230 are spaced apart by the circumferential lip portion 265 located therebetween.

10 [0135] By this arrangement after reclosure the first and second circumferential edges 270, 275 are no longer adjacent but spaced, thus revealing a void or gap substantially comprising groove 260 and lip portion 265 between the first and second circumferential edges 270, 275. This visual indicator evidences that the closure assembly 5 (and container 215) has been opened and reclosed and therefore provides further tamper indication or tamper-evident means.

15 [0136] In a modification at or near the first circumferential edge 270 of the first outer sleeve 225 there can be provided a first circumferential beaded portion on the first outer sleeve 225 adjacent first circumferential edge 270, and in a same manner the second circumferential edge 275 of the second outer sleeve 230 may provide a second circumferential beaded portion on the second outer sleeve 230 adjacent second circumferential edge 275.

20 [0137] The first and second sleeves 225, 230 are made from any suitable material, e.g. a metal, or metallic based material. In this case the metal substantially comprises aluminium or an alloy thereof, e.g. rolled aluminium. Aluminium provides a good medium for application of printing dyes, inks, paints or the like such that messages, logos, images, names, and other information may be carried by the first and second outer sleeves 225, 230.

25 [0138] The cap 20 includes internally threaded portion 110 which co-acts with external threaded portion 115 on sleeve 220 or pouring outlet device 95, and allows for a rotational movement (normally-anti-clockwise) of the cap 20 during a container opening operation, and a contra-rotational movement (normally clockwise) of the cap 20 during a container closing (reclosing) operation.

30 [0139] The closure assembly 5 includes a non-refillable device 290 comprising valve member 75 and providing pouring outlet device 95 adapted to be secured to the mouth 10 of the container 215 for liquid. The cap 20 is adapted to close an outlet 300 of the pouring outlet device 95, the first outer sleeve 225 optionally being located to receive at least part of the pouring outlet device 95. The outlet 300 is substantially annular and the cap 235 carries on an inner facing end 305 an annular seal 310 removably receivable within the annular outlet 300. The annular outlet 300 defines a circumferential pouring lip 96.

35 [0140] The second outer sleeve 230 is adapted to receive the cap 20. The cap 20 is generally received in a tight interference fit to the second outer sleeve 230, but may be rotatable with respect to the second outer sleeve 235 upon application of sufficient force. For example, upon reclosure of the closure assembly 5, when circumferential lip portion 265 abuts first circumferential edge 270 further reclosure movement (e.g., clockwise turning of second outer sleeve 225) can cause cap 20 to remain stationery and outer sleeve 225 to rotate relative thereto. Further, the second circumferential edge 275 maintains the second outer sleeve 230 in longitudinal relation with the cap 20.

40 [0141] The pouring outlet device 95 is, in this embodiment, made in one piece with the sleeve 220, e.g. by injection moulding.

[0142] The non-refillable device 290 further comprises valve seat body 90 which is at least partially receivable within at least part of the neck portion 211 of the container 215, the valve seat body 90 being at least partially surrounded by the sleeve 220. Moveable valve member 75 is provided within the valve seat body 90.

45 [0143] A non-return valve is formed from the valve seat body 90 and valve member 75 which is closed in a normally upright position of the bottle 215, and which while allowing liquids to flow from the bottle 215 in a pouring operation, restricts in-flow of liquid into the bottle 215 by rudimentary unauthorised filling operations or even more sophisticated methods which may involve attempted insertion of objects, tubes or the like into the bottle mouth 210.

50 [0144] There are provided means for retaining the first outer sleeve 225 in longitudinal relation to the sleeve 220, e.g. an end 226 of the first outer sleeve 225 formed (bent) over an end 220 of the sleeve 220.

55 [0145] The first and second circumferential edges 270, 275 of the first and second outer sleeves 270, 275 are before an initial opening of the closure assembly 5 located within the circumferential groove 260 provided on the cap 20, and are substantially adjacent. This positioning ensures that when the container 215 is initially opened by relative twisting of the cap 20 and sleeve 220, the second circumferential edge 275 of the second outer sleeve 230 remains within the groove 260 provided on the cap 20, and the first circumferential edge 270 of the first outer sleeve 225 progressively resiliently can be caused to move circumferentially outward and out of the groove 260 provided on the cap 235 as the cap 235 is removed away from the pouring outlet device 295 and the first outer sleeve 225 portion. Alternatively or additionally as mentioned above, the circumferential lip portion 265 can progressively resiliently move circumferentially

inward. On removing the contact between the cap 20 and the first circumferential edge 270 of the first outer sleeve 225, the first circumferential edge 270 retracts to a substantially reduced circumference (e.g. its original circumference), such that the resulting circumference is less than that of a cap portion which is located below the groove 260, e.g. circumferential lip portion 265.

5 [0146] When the cap 20 is re-applied to the pouring outlet device 95, a stop position is reached when the circumferential lip portion 265 of the cap 20 rests, sits or abuts upon the first circumferential edge 270 of the first outer sleeve 225, thus preventing the cap 20 being returned to its original starting (unopened) position. A longitudinal gap or void therefore remains between the first and second outer sleeves 225, 230 thus exposing a circumferential part of the cap 20, which includes at least part of the circumferential lip portion 265 which was originally encased or enclosed within the first outer sleeve 225. A further void (not shown) also exists between a lower edge of the cap 20 and an original cap seating surface 320 of the pouring outlet device 95.

[0147] Advantageously the exposed circumferential part of the cap 20 can be distinctly coloured and/or printed with information, promotional messages or the like.

15 [0148] The fixing means comprise first means 325 for fixing the sleeve 220 on the container 215 so as to restrain rotational movement of the sleeve 220 with respect to the neck portion 211 of the container 215.

[0149] The fixing means also comprise second means 330 for fixing the sleeve 220 on the container 215 so as to restrict longitudinal movement of the sleeve 220 with respect to the mouth 210 of the container 215. The second means 330 for fixing the sleeve 220 are in the form of at least one projecting means 330 projecting inwardly of said sleeve 220, said at least one projecting means 330 being moveable radially of the sleeve 230 in a stiffly resilient manner and being engagable with an outer lip portion 212 of said container 215.

20 [0150] The first outer sleeve 225 fits with the sleeve 220 by means of an interference fit between an outer surface 340 of the sleeve 220 and an inner surface 345 of the first outer sleeve 225. The cap 20 has therein threaded portion 285, which engages with a corresponding threaded portion 115 on the pouring outlet device 95.

[0151] It is desired that the first and second outer sleeves 225,230 are aesthetically pleasing, and as such, the first and second outer sleeves 225,230 comprise metal foil.

25 [0152] There are provided means 346 for assembling the sleeve 220 and valve seat body 90 together prior to application to the container 215, such as co-acting ribs and grooves carried by each.

[0153] The projecting means 330 are provided on an inner wall of the sleeve 220 to resiliently engage the neck portion 211 and outer lip portion 212 of the container 215.

30 [0154] The sleeve 220 contains one or more circumferential apertures 315 around the sleeve 220, which are defined between axially extending portions of the sleeve 220. The/each projecting means 330 are provided adjacent to an edge of one of the apertures 315.

[0155] As can be seen in this closure assembly 5, each projecting means 330 is positioned on a lower circumferential edge 360 of one of the apertures 315.

35 [0156] The baffle 15 is provided with a circumferentially extending brim 390 which is positioned on the lower outer edge 395 of said baffle 15.

[0157] The sleeve 220 is further conveniently provided with a plurality of ribs (or ridges) 405 formed on an inner surface 410 thereof, in this embodiment arranged circumferentially around the sleeve 220 and having their long axes arranged substantially axially to said sleeve 220. These ribs 405, in use, form first means 325 for anti-rotation and co-act with raised lips, ridges or the like (not shown), on an outer surface of the container 215 (comprising a so-called "glass finish" of the bottle) to seek to prevent undesired rotational movement of the sleeve 220.

[0158] Some minor rotational play in either a clockwise or anticlockwise direction may occur until a stop position is found by a rib or ribs 405 acting against a ridge or ridges. However, continued application of force will cause the first outer sleeve 235 and/or the second outer sleeve 230 to rotate relative to the sleeve 220 and/or cap 235, respectively.

45 [0159] The valve seat body 90 comprises a tubular portion 410, a free end portion 415 of which provides a valve seat 420 adapted to be contacted in a sealing manner by valve member 7 captive in the tubular portion 410. The valve seat 420 comprises a circumferentially extending flange 421, which extends radially inwardly of the tubular portion 410. In this embodiment the valve seat 420 is positioned at one end of the tubular portion 410, and that end of the tubular portion 410 is closed except for an aperture which in this case is circular aperture 425.

50 [0160] The tubular portion 410 is adapted to be received substantially within the mouth 210 portion of the container 215. The tubular portion 410 further comprises at least one engagement means 430 on an outer surface 235 thereof to engage an inner surface 440 of the container 215 in an interference fashion. The engagement means 430 comprise radially extending circumferential ribs.

55 [0161] At or near to an end of the tubular portion 410 distant from the valve seat 420 is provided a substantially concentric further tubular portion 445 of greater diameter than the tubular portion 410, and an inner surface 445 of the further tubular portion 445 is connected to an outer surface 455 of the tubular portion 410 by one or more further webs 460. Further, a first end 465 of the further tubular portion 445 is connected to an outer surface 455 of the tubular portion 410 by an annular flange 475. Such construction provides a circumferential trough 480 defined between the outer surface

470 of the tubular portion 410 and an inner surface 450 of the further tubular body 475 with the flange 75 forming a trough floor. The trough 480 is divided into smaller arc-shaped troughs 485 by the webs 460. Such a trough 480 and/or troughs 485 help prevent insertion of objects into the container 215 through the closure assembly 5.

[0162] A second end 490 of the further tubular portion 445 is arranged substantially flush with an end 495 of the tubular portion 410 distant from the valve seat 420.

[0163] In use, the tubular portion 410 forms an inner sleeve of the assembled closure assembly 5.

[0164] An outer surface 500 of the further tubular body 445 interference interacts with an inner surface 505 of the sleeve 420. Conveniently, a radially extending circumferential rim 510 is located on an outer edge 515 of an end of the further tubular body 445, which, in an assembled closure assembly 5 is seated against a lower surface of a radially inwardly extending circumferential rim 425 provided on an inner surface of the sleeve 220.

[0165] The container 215 is preferably a container for liquid. The container 215 is most likely a bottle, e.g. a glass bottle, suitable for containment of liquid, such as alcoholic drinks or beverages, e.g. spirits such as vodka, whisky, brandy, gin or the like.

[0166] Typically, the bottle 215 is made from glass or alternatively a plastics material, the first and second outer sleeves 225, 230 from aluminium, the cap 20 from low density polyethylene, the sleeve 220 and pouring outlet device 95 from a stiffly resilient plastics material such as polypropylene or polystyrene and which in this embodiment is a polystyrene obtainable under the trade name, STYROLUX, the first tamper indication means 10 from polycarbonate, and the valve seat body 315 from low density polyethylene.

[0167] A method of manufacturing the closure assembly 5 according to the present invention comprises the steps of:

- (a) providing an outer sleeve member 224;
- (b) providing pouring outlet device 95 and sleeve 220 adapted to be secured to mouth and/or neck portion 210,211 of container 215 for liquid, and container closure member 20 releasably securable to the pouring outlet device 95 and/or sleeve 220;
- (c) disposing the pouring outlet device 95, sleeve 220 and container closure member 20 at least partly within the outer sleeve member 224;
- (d) forming the outer sleeve member 224 into first outer sleeve 225 and separate second outer sleeve 230.

[0168] As mentioned hereinbefore, the ball 35 can be inserted into the valve seat body 90 by pushing the ball 35 through aperture 425.

[0169] This method is particularly advantageous in mass production. Step (d) is carried out using a first cutting tool such as a blade of a machine tool (not shown).

[0170] Step (d) comprises: forming a cut around a portion of the outer sleeve member 224 so as to form the adjacent first and second circumferential edges 270 on the first and second outer sleeves 225,230. In this way the blade forms cut line 231 hereinbefore mentioned.

[0171] As can be seen from Figure 1(a), where provided, the first and second circumferential edges are formed in circumferential groove 260 carried on the container closure member 20. Also as can be seen, the first and second circumferential edges 275 are of reduced diameter compared to at least adjacent portions of the first or second outer sleeves 225,230 respectively.

[0172] After step (c) the method also comprises the step of: (e) forming end 226 of the first outer sleeve 225 over end 320 of the sleeve 220 so as to retain the first outer sleeve 225 and the sleeve 220 in longitudinal relation. Step (e) is carried out using a second cutting tool such as a further blade (not shown) of the machine tool. Steps (d) and (e) are beneficially undertaken substantially simultaneously, e.g. for reasons of speed of manufacture.

[0173] The closure assembly 5 formed by this method comprises a unitary assembly for snap-on application to a mouth and neck portion 210, 211 of a container 215.

[0174] A method of bottling according to the present invention comprises:

- (a) providing closure assembly 5;
- (b) providing a bottle 215;
- (c) filling the bottle 215 with a liquid;
- (d) closing the bottle 215 by applying the closure assembly 5 to a mouth and neck portion 210,211 of the bottle 215.

[0175] Referring next to Figures 4(a) to (e), there are shown a sequence of cross-sectional side views of a closure assembly (tamper-evident device), generally designated 5a, according to a second embodiment of the present invention. The second embodiment is in many respects similar to the first embodiment hereinbefore described, like parts being designated with like numerals but suffixed "a".

[0176] However, in the second embodiment the second retaining means 30a comprises a female portion 50a, provided on the baffle 15a, and a corresponding male portion 55a provided on an inner face 60a of a retaining member or sealing

wad 61a. As can be seen from Figure 4(a), the female portion 50a and male portion 55a are initially held together by an interference fit, which releases upon initial opening. Further, the retaining member 61a is fixedly secured to the closure member 20a by lock means 62a, i.e. coacting ribs and grooves on the retaining member 61a and the closure member 20a.

[0177] Referring finally to Figures 5(a) to (e), there are shown a sequence of cross-sectional side views of a closure assembly (tamper-evident device), generally designated 5b, according to a third embodiment of the present invention. The third embodiment is in many respects similar to the first and second embodiments hereinbefore described, like parts being designated with the numerals, but suffixed "b".

[0178] However, in the third embodiment there is no baffle or second retaining means. Rather, the first retaining means 25b prior to initial opening retains the first member 10b in association with the container closure member 20b. The first retaining means 25b comprises female portion 50b provided on the ball 35b, and a corresponding male portion 55a provided on an inner face 60b of retaining member or sealing wad 61b. As can be seen from Figure 5(a), the female portion 50b and male portion 55b are initially held together by an interference fit which releases upon initial opening.

[0179] The third embodiment provides a number of advantages over the other disclosed embodiments, e.g. a requirement for only one retaining means.

[0180] In a modification to the second and third embodiments, the interference fit between the female portion 50b and the male portion 55b may be modified by provision of a positive clip therebetween, e.g. coacting groove and ribs, ball and socket, or the like.

[0181] It will be understood that the embodiments of the present invention hereinbefore described are given by way of non-limiting example only, and that modifications may be made without departing from the scope of the present invention as set forth in the appended claims.

[0182] It will particularly be appreciated that the first retaining means are weaker than the second retaining means, but that both first and second retaining means are strong enough for transit purposes.

[0183] It will also be appreciated that the provision of the releasable push-fit first and optional second retaining means provide a particularly simple to manufacture, assemble, and use solution to the aforementioned problems in the art.

[0184] It will be further appreciated that the present invention provides a particularly desirable and elegant one-piece snap-on fitment having functional advantages over the prior art as well as enhanced aesthetic appeal.

[0185] In a modification, the second outer sleeve and/or the first outer sleeve may include knurled or castellated surfaces to assist in gripping in opening and reopening and/or closing and reclosing of the closure assembly.

[0186] Finally, it will be appreciated that in at least one disclosed embodiment of the closure assembly of the present invention prior to an initial opening, the first and second circumferential edges of the first and second outer sleeves are substantially adjacent one another and may indeed even abut. However, they are preferably not connected together, e.g. by any frangible or weakened break-line, frangible or weakened links or frangible and/or removable tear ring, but rather are distinct and separate one from the other.

Claims

1. A closure assembly (5) adapted to be applied to a mouth (210) and neck portion of a container for liquid, comprising:

- a sleeve (220) adapted to lie substantially concentrically with respect to the mouth (210),
- means (325) for fixing the sleeve (220) on the container,
- a pouring outlet device (95), with a liquid outlet, adapted to be secured to the mouth (210) of the container,
- a container closure member (20) removably fitted on said pouring outlet device (95), adapted to open and close the liquid outlet of the pouring device (95);
- a non refillable device (290) within said pouring outlet device (95),
- said sleeve (220) being adapted to receive at least part of said non refillable device (290),
- said non refillable device (290) comprising a tubular portion (410), a free end (415) of which provides a body (90) for a valve seat (420),
- a tamper indication member (10) captive in said tubular portion (410),
- said tamper indication member (10) comprising a first end (40) and a second end (80),

characterized by the fact that it includes first retaining means (25) for retaining the first end (40) of said tamper indication member (10) in association with the container closure member (20) prior to initial opening of the closure assembly (5) and for releasing said first end (40) further initial opening of the closure assembly (5), whereby said tamper indication member (10) is caused to drop from an initial position to a further position which indicates the initial opening of the closure assembly (5), the first end (40) of the tamper indication member (10) is caused to act on said valve seat (420) in a sealing manner and said second end (80) is caused to act as a visual tamper-evidence indication means.

EP 1 585 684 B1

2. A closure assembly as claimed in claim 1, wherein the closure member (20) comprises a cap which is threadably connected to the pouring outlet device (95) by interengaging threaded portions on each.
- 5 3. A closure assembly as claimed in claims 1 and 2, wherein said first retaining means (25) for retaining the first end (40) of said tamper indication member (10) in association with the container closure member (20), comprises a releasable push/clip/interference fit retaining means.
- 10 4. A closure assembly according to claims 1 to 3, wherein said first end (40) of the tamper indication member (10) acting on said valve seat (420) after initial opening of the closure, comprises a ball portion (35).
- 5 15 5. A closure assembly according to claims 1 to 4 wherein said second end (80) of the tamper indication member (10) comprises a flag member.
- 15 6. A closure assembly according to claim 5 wherein the flag is suitably coloured to attract the eye and/or carries information, such as marketing or promotional information.
- 20 7. A closure assembly according to claim 1 to 6, wherein a baffle (15) is provided in association with the container closure member (20), second retaining means (30) being provided for retaining said baffle (15) in association with the container closure member (20) and said first retaining means (25) being provided for retaining the first end (40) of said tamper indication member (10) in association with the baffle (15).
- 25 8. A closure assembly according to claim 7, wherein said first retaining means (25) comprises a ball (35) carried at the first end (40) of the tamper indication member (10) and a corresponding socket (45) provided on the baffle (15).
- 30 9. A closure assembly according to claim 7, wherein said second retaining means (30) comprises a male/female portion provided on the baffle (15) and a corresponding female/male portion provided on an inner face of the container closure member (20).
- 35 10. A closure assembly according to the preceding claims, wherein in an initial unopened position there are provided means for preventing movement of the tamper indication member (10) in a direction towards the container closure member (20).
11. A closure assembly according to claim 10, wherein the movement prevention means comprise a widened second end (80) of the tamper indication member (10) and an abutting surface (85) of the valve seat body (80).

Patentansprüche

- 40 1. Verschlussanordnung (5), ausgelegt für die Anbringung an einer Öffnung (210) und einem Halsabschnitt eines Behälters für eine Flüssigkeit, umfassend:
 - eine Hülle (220), die ausgelegt ist, im Wesentlichen konzentrisch zur Öffnung (210) zu liegen,
 - Mittel (325) zur Fixierung der Hülle (220) am Behälter,
 - eine Gießauslassvorrichtung (95) mit einem Flüssigkeitsauslass, die ausgelegt ist, an der Öffnung (210) des Behälters befestigt zu werden,
 - 45 - ein Behälterverschlusselement (20), das entfernbar auf der Gießauslassvorrichtung (95) aufgesetzt ist und ausgelegt ist, den Flüssigkeitsauslass der Gießauslassvorrichtung (95) zu öffnen und zu schließen;
 - eine Nicht-Wiederbefüllungs-Vorrichtung (290) innerhalb der Gießauslassvorrichtung (95),
 - wobei die Hülle (220) ausgelegt ist, wenigstens einen Teil der Nicht-Wiederbefüllungs-Vorrichtung (290) aufzunehmen,
 - 50 - wobei die Nicht-Wiederbefüllungs-Vorrichtung (290) einen rohrförmigen Abschnitt (410) umfasst, dessen freies Ende (415) einen Körper (90) für einen Ventilsitz (420) bereitstellt,
 - ein Eingriffanzeigeelement (10), das in dem rohrförmigen Abschnitt (410) gefangen ist,
 - 55 - wobei das Eingriffanzeigeelement (10) ein erstes Ende (40) und ein zweites Ende (80) aufweist, und durch das Merkmal **gekennzeichnet**, dass es erste Rückhaltemittel (25) beinhaltet, um das erste Ende (40) des Eingriffanzeigeelements (10) in Verbindung mit dem Behälterverschlusselement (20) vor dem Initialöffnen der Verschlussanordnung (5) zurückzuhalten und um das erste Ende (40) nach dem Initialöffnen der Verschlussanordnung (5) freizugeben, wodurch bewirkt wird, dass das Eingriffanzeigeelement (10) von einer Initialstellung

EP 1 585 684 B1

in eine weitere Stellung fällt, welche das Initialöffnen der Verschlussanordnung (5) anzeigt, wodurch bewirkt wird, dass das erste Ende (40) des Eingriffanzeigeelements (10) auf den Ventilsitz (420) in dichtender Weise einwirkt und bewirkt wird, dass das zweite Ende (80) als ein sichtbares Eingriffsnachweis-Anzeigemittel wirkt.

- 5 2. Verschlussanordnung gemäß Anspruch 1, worin das Verschlusselement (20) eine Kappe umfasst, welche mit der Gießauslassvorrichtung (95) durch den wechselseitigen Eingriff von Gewindeabschnitten an beiden schraubverbunden ist.
- 10 3. Verschlussanordnung gemäß den Ansprüchen 1 und 2, worin die ersten Rückhaltemittel (25), um das erste Ende (40) des Eingriffanzeigeelements (10) in Verbindung mit dem Behälterverschlusselement (20) zurückzuhalten, ein lösbares Druck-/Klipp-/Prossitz-Rückhaltemittel umfasst.
- 15 4. Verschlussanordnung gemäß den Ansprüchen 1 bis 3, worin das erste Ende (40) des Eingriffanzeigeelements (10), das auf den Ventilsitz (420) in dichtender Weise nach dem Initialöffnen des Verschlusses einwirkt, einen Kugelabschnitt (35) umfasst.
- 20 5. Verschlussanordnung gemäß den Ansprüchen 1 bis 4, worin das zweite Ende (80) des Eingriffanzeigeelements (10) ein Markierungselement umfasst.
- 25 6. Verschlussanordnung gemäß Anspruch 5, worin die Markierung geeignet gefärbt ist, um das Auge des Betrachters auf sich zu lenken und/oder Information, wie Information betreffend die Vermarktung oder Verkaufsförderung, trägt.
- 30 7. Verschlussanordnung gemäß Anspruch 1 bis 6, worin ein Schutzschirm (15) in Verbindung mit dem Behälterverschlusselement (20) vorgesehen ist, zweite Rückhaltemittel (30) vorgesehen sind, um den Schutzschirm (15) in Verbindung mit dem Behälterverschlusselement (20) zurückzuhalten und die ersten Rückhaltemittel (25) vorgesehen sind, um das erste Ende (40) des Eingriffanzeigeelements (10) in Verbindung mit dem Schutzschirm (15) zurückzuhalten.
- 35 8. Verschlussanordnung gemäß Anspruch 7, worin die ersten Rückhaltemittel (25) eine Kugel (35), die vom ersten Ende (40) des Eingriffanzeigeelements (10) getragen wird und eine entsprechende Pfanne (45), die am Schutzschirm (15) vorgesehen ist, umfassen.
- 40 9. Verschlussanordnung gemäß Anspruch 7, worin die zweiten Rückhaltemittel (30) einen männlichen/weiblichen Abschnitt, der an dem Schutzschirm (15) vorgesehen ist und einen entsprechenden weiblichen/männlichen Abschnitt, der an einer Innenfläche des Behälterverschlusselements (20) vorgesehen ist, umfassen.
- 45 10. Verschlussanordnung gemäß den vorhergehenden Ansprüchen, worin in der ungeöffneten Initialstellung Mittel vorgesehen sind, um die Bewegung des Eingriffanzeigeelements (10) in Richtung des Behälterverschlusselements (20) zu behindern.
- 50 11. Verschlussanordnung gemäß Anspruch 10, worin die Bewegungsverhinderungsmittel ein aufgeweitetes, zweites Ende (80) des Eingriffanzeigeelements (10) und eine Anliefläche (85) des Ventilsitzkörpers (80) umfassen.

45 Revendications

- 50 1. Ensemble de fermeture (5) prévu pour être appliqué sur l'embouchure (210) et le col d'un récipient pour liquide, comportant :
 - 55 - un manchon (220) prévu pour s'étendre de manière sensiblement concentrique par rapport à l'embouchure (210),
 - des moyens (325) pour fixer le manchon (220) au récipient,
 - un dispositif verseur (95) avec un conduit d'écoulement prévu pour être fixé sur l'embouchure (210) du récipient,
 - un élément de fermeture de récipient (20) monté de manière amovible sur le dispositif verseur (95) et prévu pour ouvrir et refermer le conduit d'écoulement du dispositif verseur (95),
 - un dispositif non ré-emplissable (290) disposé à l'intérieur dudit dispositif verseur (95),
 - ledit manchon (220) étant prévu pour recevoir au moins une partie dudit dispositif non ré-emplissable (290),
 - ledit dispositif non ré-emplissable (290) comportant une partie tubulaire (410), dont une extrémité libre (415)

EP 1 585 684 B1

forme un corps (90) pour un logement de valve (420),
- un élément indicateur d'erreur (10) enfermé à l'intérieur de ladite partie tubulaire (410),
- ledit indicateur (10) comportant une première extrémité (40) et une deuxième extrémité (80),

- 5 **caractérisé par le fait qu'il** comporte des premiers moyens de retenue (25) pour maintenir la première extrémité (40) dudit indicateur (10) associée à l'élément de fermeture (20) du récipient avant l'ouverture initiale de l'ensemble de fermeture (5) et pour libérer ladite première extrémité (40) après l'ouverture initiale de l'ensemble de fermeture (5), dans lequel ledit indicateur (10) est déplacé à partir d'une position initiale vers une autre position qui indique l'ouverture initiale de l'ensemble de fermeture (5), la première extrémité (40) de l'indicateur (10) étant amenée à agir sur ledit logement de valve (420) pour la refermer et ladite extrémité (80) étant amenée à agir comme indicateur visuel.
- 10
- 15
- 20
- 25
- 30
- 35
- 40
- 45
- 50
- 55
2. Ensemble de fermeture selon la revendication 1, dans lequel l'élément de fermeture (20) comporte un couvercle qui est relié par vissage au dispositif verseur (95) par inter-engagement des zones filetées respectives.
 3. Ensemble de fermeture selon les revendications 1 et 2, dans lequel les premier moyens de retenue (25) pour maintenir la première extrémité (40) de l'indicateur (10) associée à l'élément de fermeture du récipient (20) comportent des moyens de maintien désengageables de type poussoir/clip/interaction.
 4. Ensemble de fermeture selon les revendications 1 à 3, dans lequel la première extrémité (40) de l'indicateur (10) qui agit sur ledit logement de valve (420) après ouverture initiale de la fermeture, comporte un élément en forme de boule (35).
 5. Ensemble de fermeture selon les revendications 1 à 4, dans lequel ladite deuxième extrémité (80) de l'indicateur (10) comporte un élément en forme d'index.
 6. Ensemble de fermeture selon la revendication 5, dans lequel l'index est coloré de manière appropriée pour attirer l'oeil et/ou transmettre des informations, telles que des informations de mercatique ou promotionnelles.
 7. Ensemble de fermeture selon l'une des revendications 1 à 6, dans lequel un écran (15) est prévu pour être associé à l'élément de fermeture de récipient (20), lesdits deuxièmes moyens de retenue (30) étant prévus pour maintenir ledit écran (15) associé à l'élément de fermeture de récipient (20) et lesdits premiers moyens de retenue (25) étant prévus pour maintenir la première extrémité (40) de l'indicateur (10) associée à l'écran (15).
 8. Ensemble de fermeture selon la revendication 7, dans lequel lesdits premiers moyens de retenue (25) comportent une boule (35) supportée à la première extrémité (40) de l'indicateur (10) et une douille correspondante (45) ménagée sur l'écran (15).
 9. Ensemble de fermeture selon la revendication 7, dans lequel lesdits second moyens de retenue (30) comportent une partie de type mâle - femelle ménagée sur l'écran (15) et une partie correspondante mâle - femelle ménagée sur une face intérieure de l'élément de fermeture de récipient (20).
 10. Ensemble de fermeture selon l'une quelconque des revendications précédentes, dans lequel on prévoit dans une position initiale non ouverte des moyens pour empêcher le mouvement de l'indicateur (10) en direction de l'élément de fermeture de récipient (20).
 11. Ensemble de fermeture selon la revendication (10), dans lequel les moyens de prévention du mouvement comportent une deuxième extrémité élargie (80) de l'indicateur (10) et une surface d'aboutage (85) sur le corps du logement de valve (80).

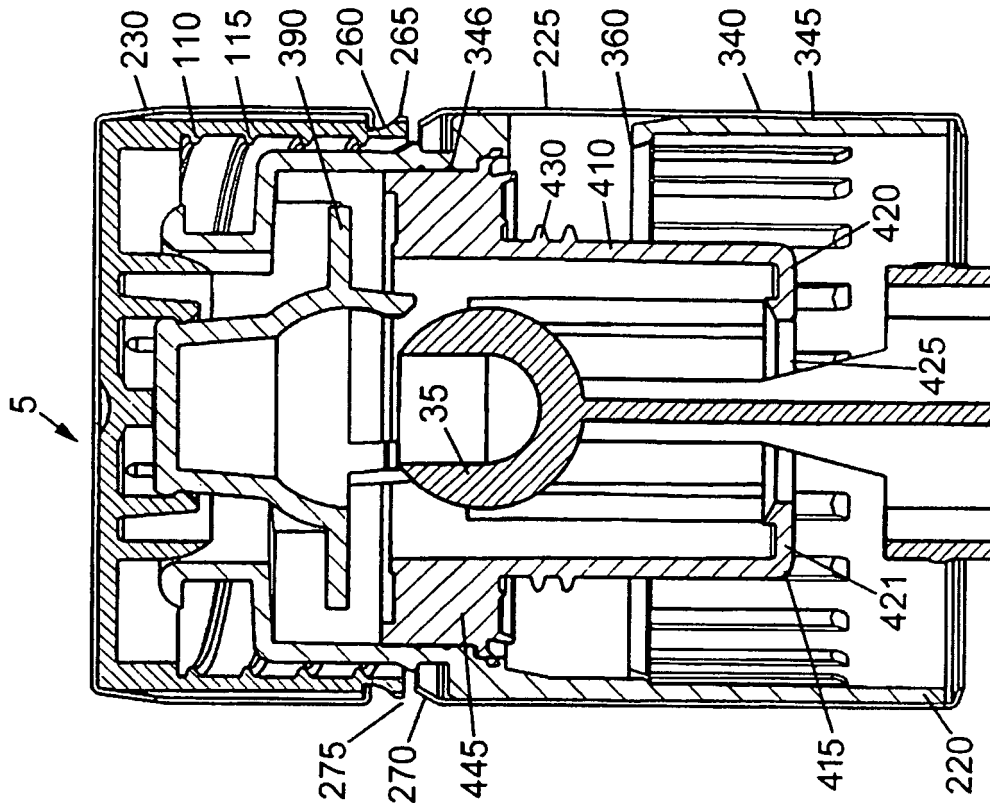

Fig. 1(b)

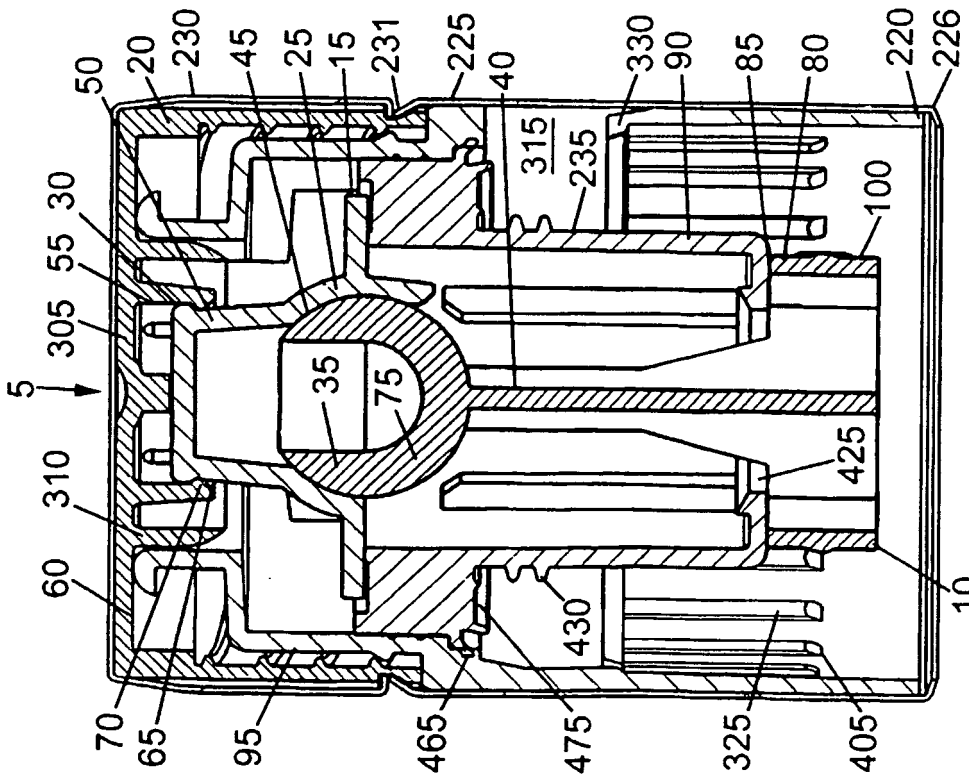

Fig. 1(a)

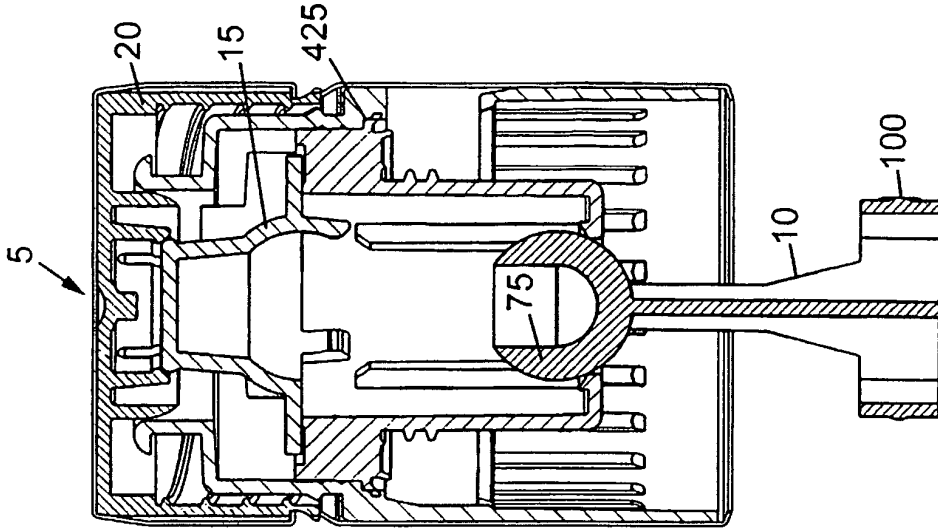

Fig. 1(d)

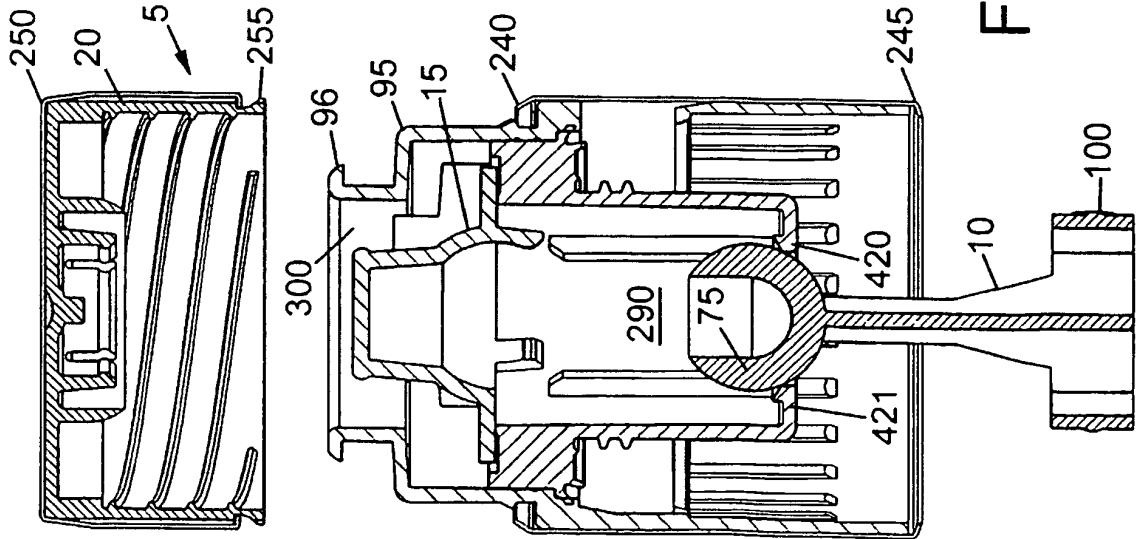

Fig. 1(c)

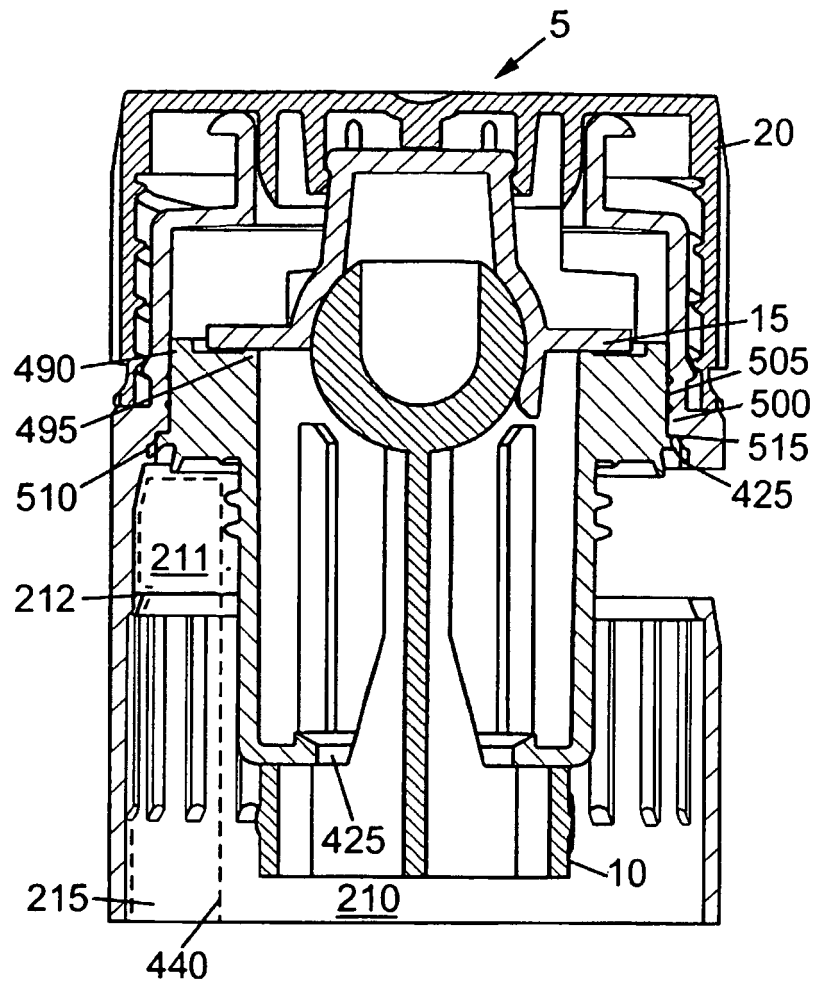

Fig. 2

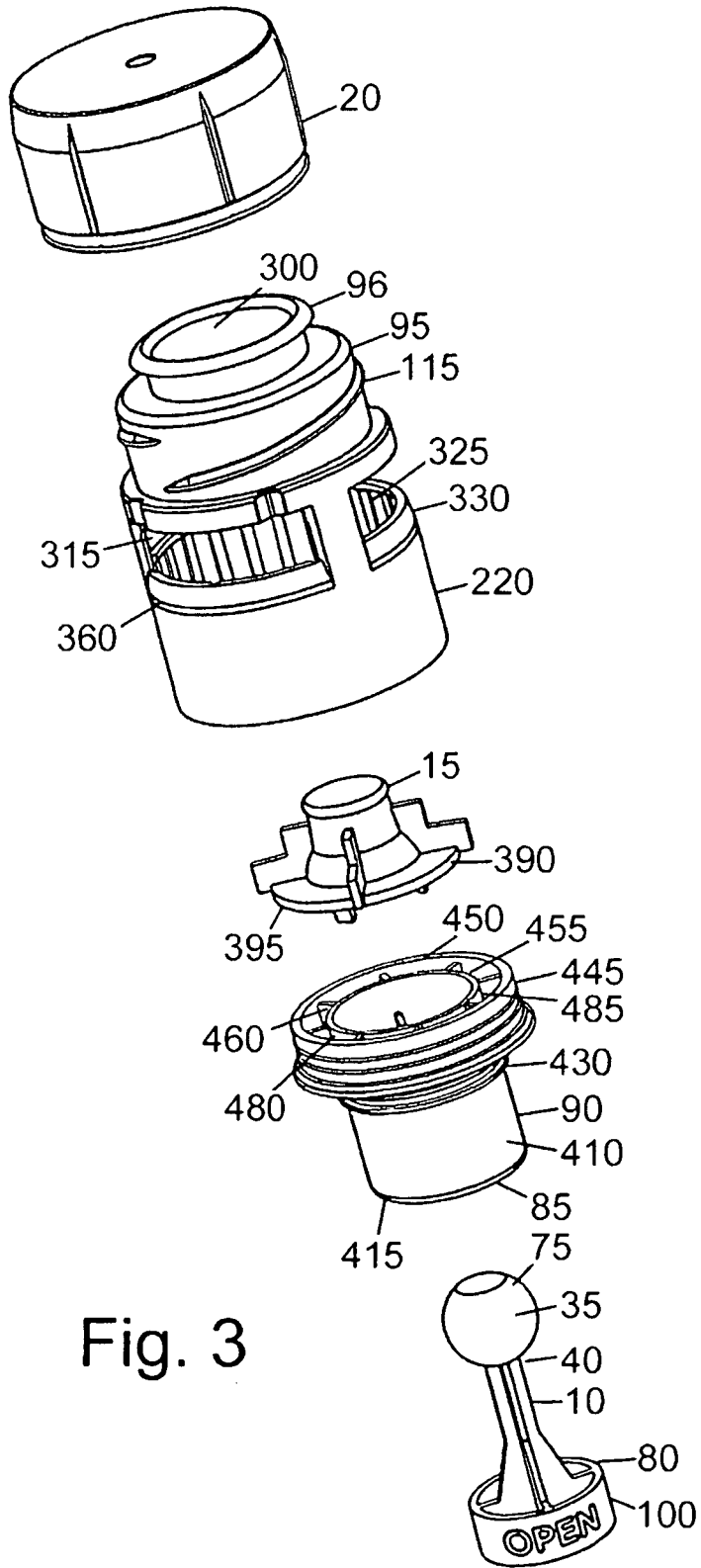

Fig. 3

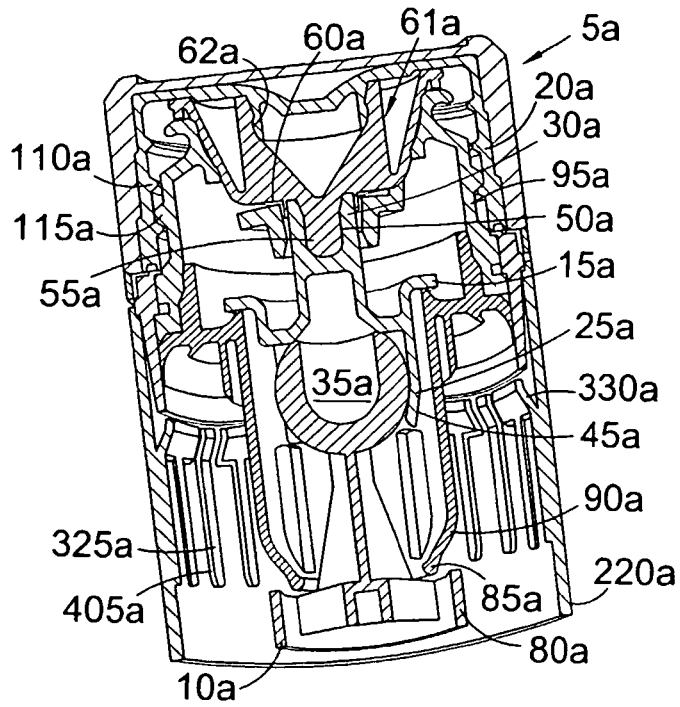

Fig. 4(a)

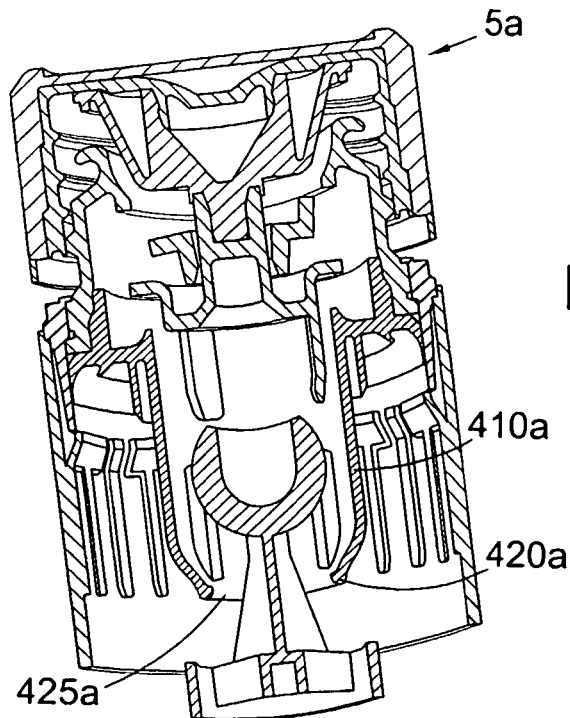

Fig. 4(b)

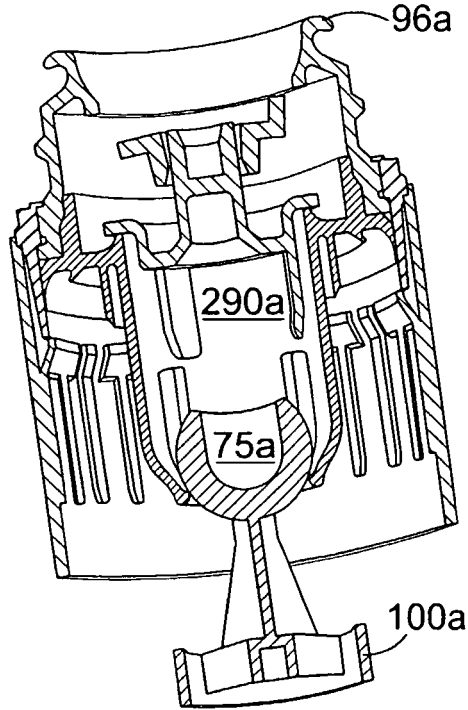
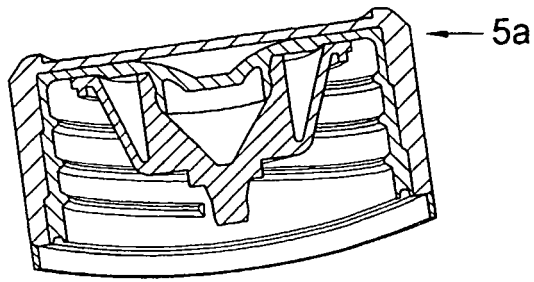

Fig. 4(c)

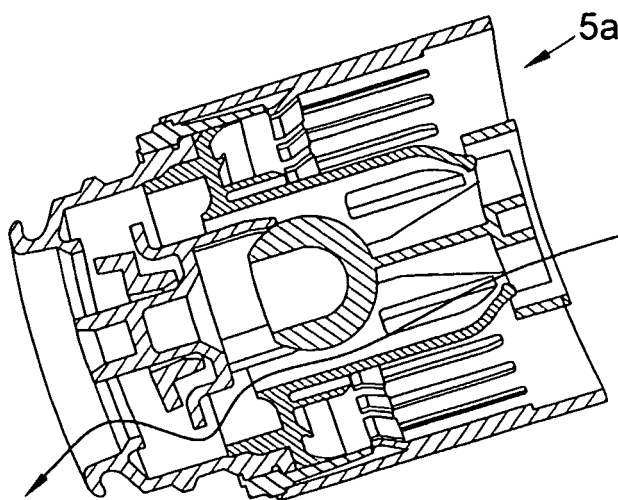

Fig. 4(d)

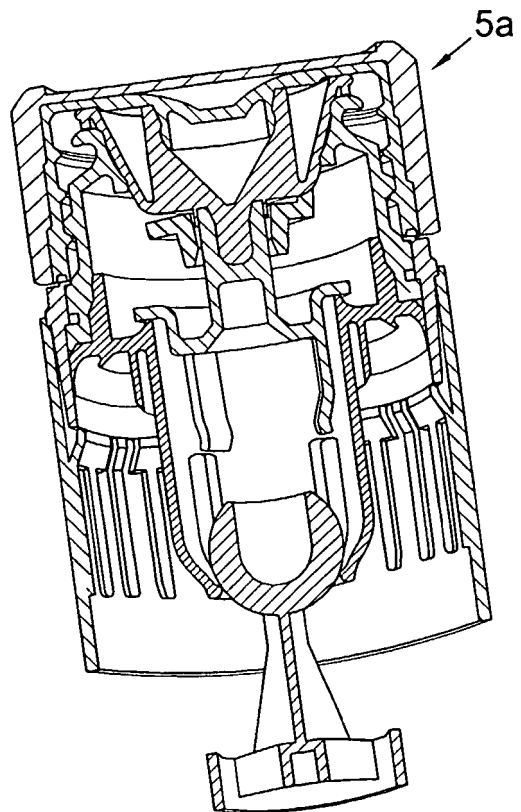
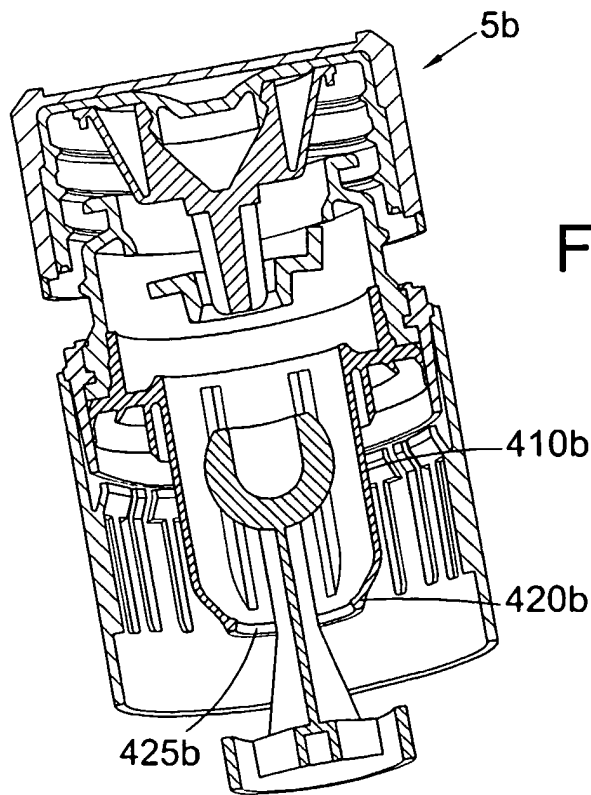
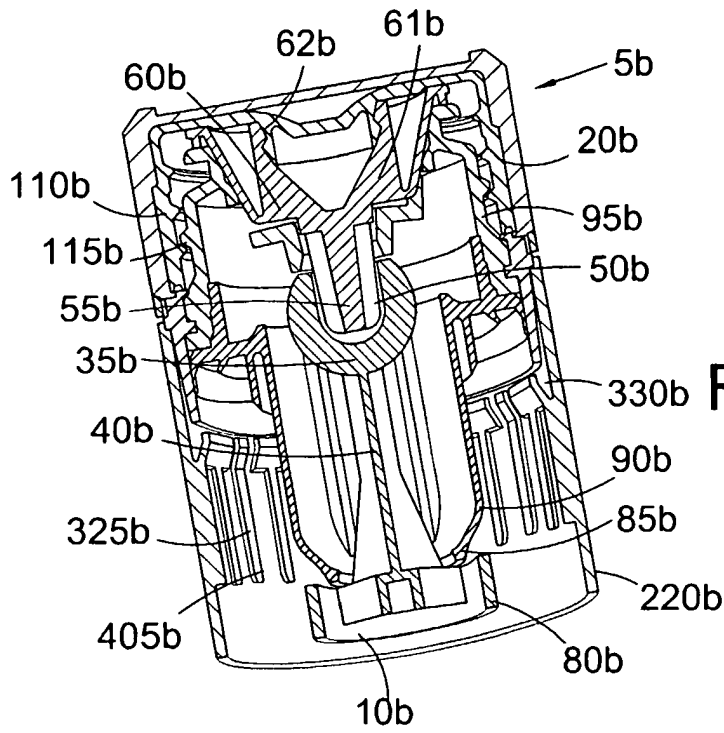

Fig. 4(e)



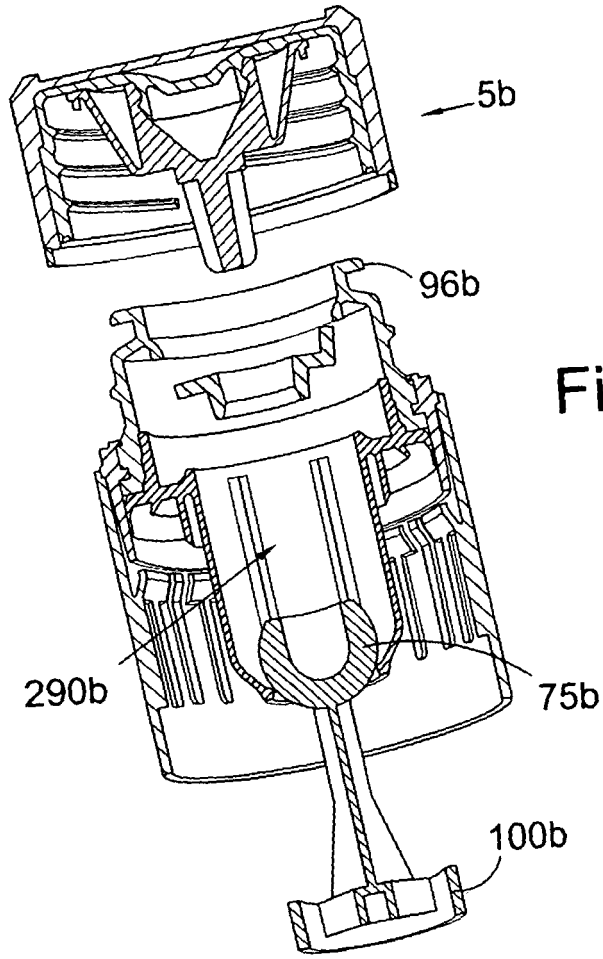

Fig. 5(c)

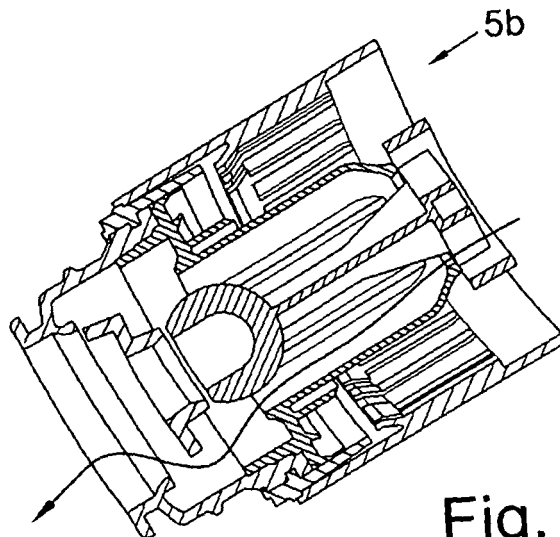

Fig. 5(d)

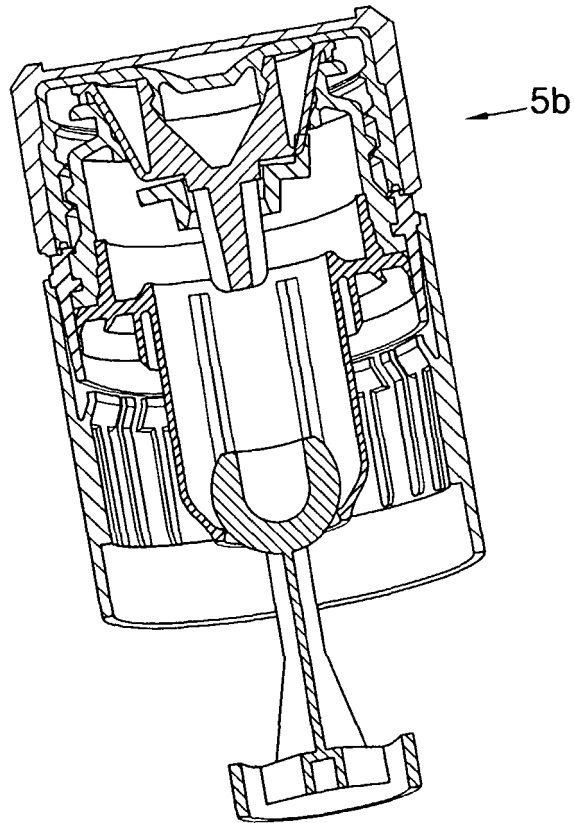

Fig. 5(e)

REFERENCES CITED IN THE DESCRIPTION

This list of references cited by the applicant is for the reader's convenience only. It does not form part of the European patent document. Even though great care has been taken in compiling the references, errors or omissions cannot be excluded and the EPO disclaims all liability in this regard.

Patent documents cited in the description

- WO 02096771 A [0001]
- GB 2274837 A [0004]
- EP 0985607 A [0010]