

(21) Application No 9807844.7	(51) INT CL <sup>6</sup> H01J 65/04
(22) Date of Filing 09.04.1998	(52) UK CL (Edition Q.) H1D DBT4 D12B1 D12B13Y D12B4 D12B47Y D12C D18AY D18A1Y D18A3A D18A3B D18A3Y D35 D5S
(71) Applicant(s) <b>Jenact Limited</b> <b>(Incorporated in the United Kingdom)</b> <b>Grove House, 25 Upper Mulgrave Road, CHEAM,</b> <b>Surrey, SM2 7BE, United Kingdom</b>	(56) Documents Cited <b>GB 2307097 A</b> <b>US 4063132 A</b> <b>Patent Abstracts of Japan, Vol 17, No 375 [E-1397] &amp;</b> <b>JP05006 2649A</b>
(72) Inventor(s) <b>Richard Anthony Rudd Little</b>	(58) Field of Search UK CL (Edition P) <b>H1D DBT4</b> INT CL <sup>6</sup> <b>A61L 2/10 , B65B 55/08 55/16 , H01J 65/00</b> <b>65/04</b> online: <b>WPI, JAPIO</b>
(74) Agent and/or Address for Service <b>Mathisen Macara &amp; Co</b> <b>The Coach House, 6-8 Swakeleys Road, Ickenham,</b> <b>UXBRIDGE, Middlesex, UB10 8BZ, United Kingdom</b>	

(54) Abstract Title  
**Apparatus for emitting light**

(57) Apparatus for emitting light at one or more predetermined wavelengths comprises an rf or microwave cavity 4 couplable to a source of rf or microwave energy of a predetermined wavelength, at least part of the cavity wall having a window constructed from a light transmissive material formed into a hollow vessel 2, the vessel containing a gas filling which in use, emits light at the predetermined one or more wavelengths when energised by rf or microwave energy of the predetermined wavelength and which attenuates rf or microwave energy at the predetermined wavelength. The apparatus may emit uv radiation, the filling being argon and mercury. Uses for curing of chemical compounds and sterilisation are described.

Fig.1A.

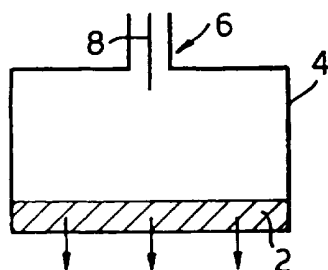
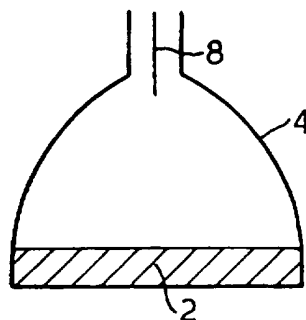

Fig.1B.



At least one drawing originally filed was informal and the print reproduced here is taken from a later filed formal copy.

The print reflects an assignment of the application under the provisions of Section 30 of the Patents Act 1977.

Fig.1A.

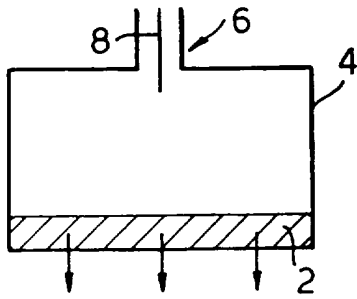

Fig.1B.

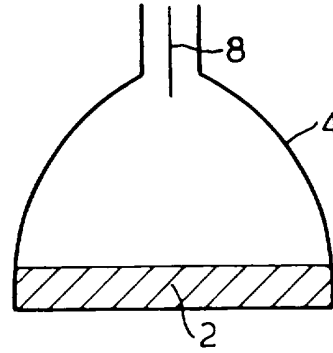

Fig.2.

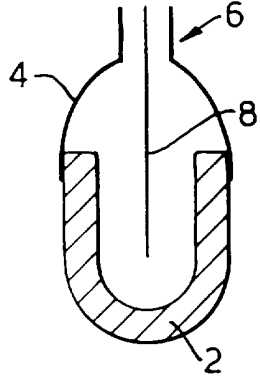

Fig.3.

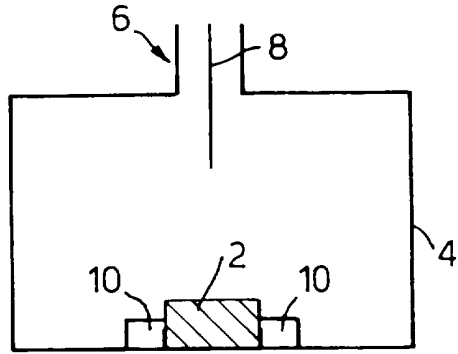

Fig.4.

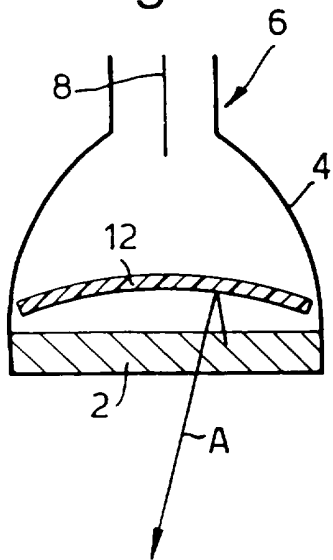

Fig.5.

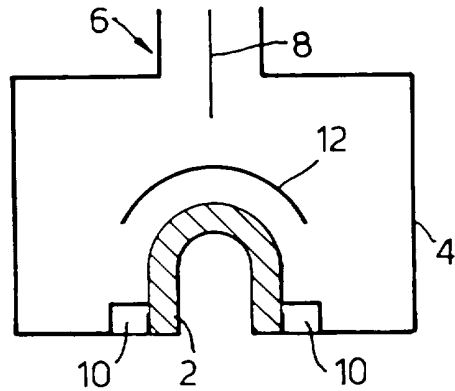

Fig.6.

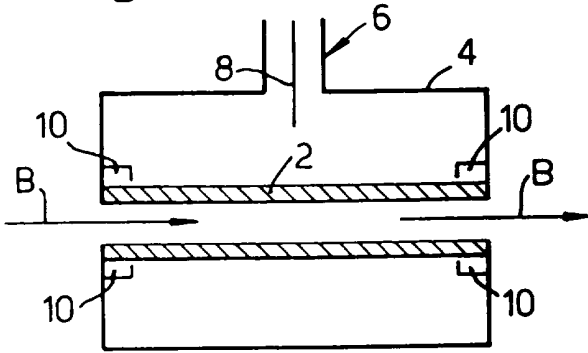

Fig.7A.

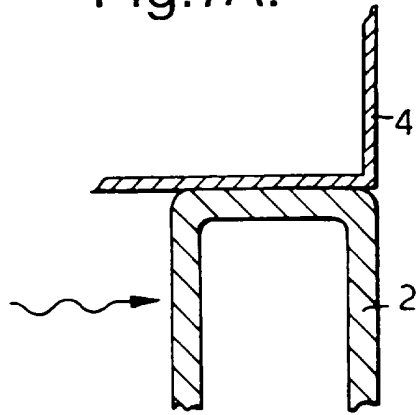

Fig.7B.

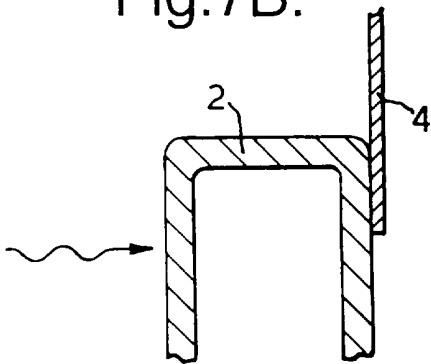

Fig.8A.

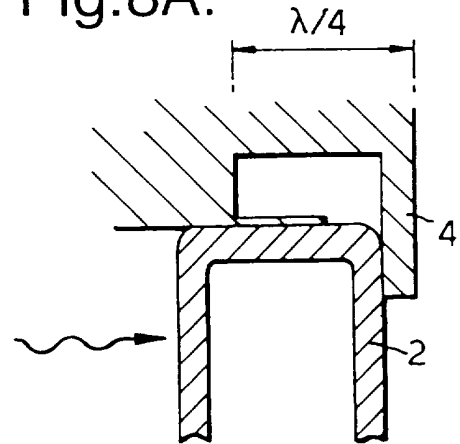
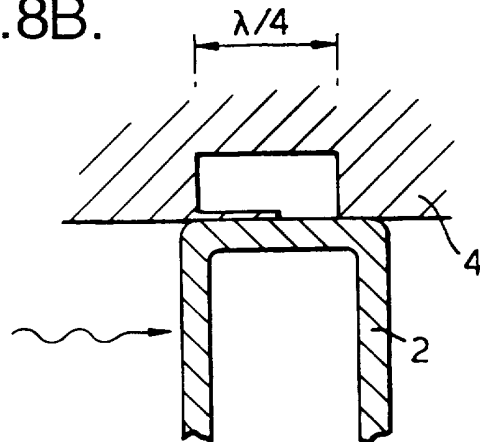

Fig.8B.



RF ENERGISED LIGHT EMITTING PLASMA

The present invention relates to apparatus for emitting light.

Lamps using energisation of UV emitting plasmas, particularly for specific spectral wavelength requirements such as curing of chemical compounds and sterilisation purposes are known. They have several advantages over arc lamps such as long lamp life, stable lamp output, and a wide variation of possible lamp envelope designs. Furthermore such lamps are electrodeless and thus the effect of fill materials on electrode materials does not need to be taken into account.

5  
10  
15  
Several methods of energising UV light emitting plasmas exist. US Patent No. 1,482,950 and US Patent No. 4,042,850 describe non-resonant microwave cavities containing a microwave energised plasma bulb, where one wall of the cavity is constructed of a mesh material which contains microwave energy in the cavity and allows the passage of UV emitted light. Since, a UV reflector forms part of the cavity, a compromise has to be reached between optimising the microwave cavity dimensions and optimising the UV light output characteristics.

20  
US Patent No. 5,166,528 and WO 96 09842A both describe resonant microwave cavities into which are placed electrodeless UV light emitting bulbs for sterilisation purposes. Sterilisation done in this way must be a batch process and articles to be sterilised must not be affected by or substantially absorb microwave radiation since in use, the articles are exposed to the energising microwave field.

25  
WO 97/35624 describes a vessel, to be placed in a microwave field constructed of materials which emit UV light when excited by microwave radiation and which attenuate microwave radiation so as to protect the contents of the vessel from said radiation. Operation is possible within a resonant or non-resonant microwave field but the techniques is suitable only for batch processes and involves complex and costly techniques for the construction of the UV emitting vessel.

30  
GB 2048589A, GB 2042252A and GB 2307097A all refer to the energisation of a UV light emitting plasma bulb by microwave radiation coupled to the bulb via a coaxial system. In each

case, provision needs to be made to prevent leakage of microwave radiation and the techniques required to do this limit the emission of UV light and the accessibility to the UV emitting plasma bulb.

5 Thus various methods of microwave energisation for the production of UV light have been developed for chemical and sterilisation processes. In all cases, the methods used for limiting or preventing microwave leakage compromise the UV light emissions by shadowing. In some cases, these methods result in the need for a batch process.

10 Additionally, exposure of the product to be treated, by UV light to microwave radiation is undesirable in some cases which prevents the use of all the above methods except that of WO97/35624. Even using the techniques of WO97/35624, the product to be exposed has to be small enough to fit into a sterilisation vessel within a microwave cavity and the process must be a batch process.

15

According to the present invention, there is provided apparatus for emitting light at one or more predetermined wavelengths comprising an rf cavity couplable to a source of rf energy of a predetermined wavelength, at least part of the cavity wall having a window constructed from a  
20 light transmissive material formed into a hollow vessel, the vessel containing a fill material which in use, emits light at the predetermined one or more wavelengths when energised by rf energy of the predetermined wavelength and which attenuates rf energy at the predetermined wavelength.

25 The cavity may be resonant or non-resonant.

The present invention allows products of any size to be irradiated on a continuous process basis by UV or visible light excited by rf (typically microwave) radiation without that light, being reduced by the necessity of providing a method of reducing or preventing rf leakage. In addition,  
30 the present invention substantially prevents a product to be irradiated from being exposed to the rf radiation.

Preferably the apparatus includes an electrically conductive rod extending generally from the rf coupling into the cavity. More particularly, the rod will be electrically coupled to the centre conductor of the coupling. The effect of this is more evenly to distribute the intensity of the light across the window.

5

Preferably at least part of the cavity wall is constructed and arranged as a reflector to direct light which is emitted from the window into the cavity back out of the cavity through the window. This increases efficiency of light emissions by using light which is emitted away from the product to be irradiated (i.e. into the cavity) back in the direction of the product.

10

Additionally or alternatively, one or more separate reflectors may be mounted in the cavity which are constructed and arranged to direct light emitted from the window into the cavity back out of the window. The materials should be transparent to the predetermined wavelength rf energy but reflective to the one or more predetermined light wavelengths. A suitable material is a PTFE-based material.

15

To further improve efficiency, either of the above reflectors or both may be focusing reflectors.

20

The window may form a recess into the cavity in which case a product to be irradiated may be inserted into the cavity. Alternatively, the window may be generally planar.

25

By arranging for the window to be generally tubular and to interconnect two faces of the cavity, it is possible to allow a continuous product to be passed through the tubular window and be irradiated by the one or more predetermined wavelengths of light during its passage therethrough.

Preferably, the window forms an outwardly curving wall of the cavity. This gives a greater spread of light.

30

The invention will now be described by way of example with reference to the drawings in which:

Figure 1A shows apparatus in accordance with the invention having a planar window;

Figure 1B shows apparatus in accordance with the invention having a planar window and a reflector formed from a cavity wall;

Figure 2 shows apparatus in accordance with the invention having an extended centre conductor;

5 Figure 3 shows apparatus in accordance with the invention having a planar window of smaller dimension than the cavity wall;

Figure 4 shows apparatus in accordance with the invention having a separate reflector mounted in the cavity;

Figure 5 shows apparatus in accordance with the invention with a recessed window;

10 Figure 6 shows apparatus in accordance with the invention with a generally tubular window, Figure 7A and 7B show alternative mounting arrangements for the window in the cavity in accordance with the invention; and

Figures 8A and 8B show alternative choke arrangements in accordance with the invention.

15 With reference to Figure 1A, it will be seen that a vessel 2 preferably constructed from an UV/visible light transmissive material is fixed in an rf/microwave cavity 4.

The vessel 2 contains a fill material which when excited to a plasma state emits UV/visible light in a desired wavelength. The vessel 2 is mounted in the cavity 4 in such a way that it forms part  
20 of the outer wall of the cavity. The cavity 4 is dimensioned to be a resonant or non-resonant cavity and may be a so-called multi-mode resonant cavity.

Rf/microwave energy fed into the cavity via coupling 6 enters the vessel 2 and excites the materials within it to form a plasma.

25

The plasma performs two functions. Firstly it emits UV/visible light outside the rf/microwave cavity. Secondly it acts as a lossy conductor thereby attenuating rf microwave radiation which otherwise would escape from the cavity 4 via the vessel 2. Also, by acting as a conductor, the shape and nature of the original rf microwave cavity may remain largely unchanged since the  
30 vessel's effect on the rf field within the cavity in use, is relatively small.

Thus, the advantages of an rf energised light emitting bulb are realised but without the disadvantages of items to be irradiated being exposed to the rf radiation and without it being necessary to place the bulb and/or the product within a microwave cavity. Thus allowing the emitted light to be used in a continuous process.

5

Preferably the materials within the UV/visible light emitting bulb are chosen to maximise the required spectral output and maximise the conductive and thus rf/microwave attenuating nature of the plasma generated. A typical fill material for the vessel 2 is argon and mercury. Typically, the internal pressure of the gas in the vessel is in the range 5 to 10 millibar and the volume of mercury is approximately 0.2 milligrams per cubic centimetre of internal volume of the vessel.

10

In Figure 1A, the vessel 2 (typically of quartz) forms a window which extends over almost the entirety of one wall of a generally cuboid cavity 4. Those parts of the cavity which are not formed by the vessel 2, typically will be metallic conductors and preferably should be reflective at the desired wavelength of light emission from the vessel. In this way, the light output of the apparatus is maximised.

15

It will be appreciated that with the arrangement in Figure 1A, light is emitted from the apparatus in many directions.

20

In Figure 1B, the cavity is at least partially shaped as a focusing reflector which increases the intensity of light emitted from the apparatus in a particular direction at the cost of reduced beam diversions.

25

Figure 2 shows an extension of the centre conductor of the rf/microwave coupling 6.

The extended centre conductor 8 acts to reduce intensity variations across the vessel 2.

30

It will be appreciated that ideally, a relatively large multi-mode cavity would be used with typical dimensions of the order of 192 millimeters by 185 millimeters by 75 millimeters with the vessel filling about a third of the width of one of the long walls of the cavity. However, with space

considerations in mind and with the possibility of forming a focusing reflector from the cavity walls, an ideal rf field distribution may not be attainable. Thus using a combination of cavity dimensions and extended centre conductor variations, it is possible to obtain suitably even illuminations across the vessel 2.

5

A typical material for the centre conductor extension may be mild steel coated with copper. With the arrangement shown in Figure 2 of a generally elliptical cavity formed by the vessel 2 and reflective walls 4 having a maximum diameter of approximately 50 millimeters and a minimum diameter of approximately 20 millimeters, the centre conductor extension has been found to be optimal at around 30 millimeters. A typical diameter for the centre conductor in that application is of the order of 1 to 2 millimeters.

10

In some applications, it may be desired to dimension the vessel 2 such that the aperture within which it fits is beyond cut off. In this case, rf chokes (typically quarterwave chokes) may be used to minimise rf leakage around the interface between the vessel and the cavity walls. Examples of applications where chokes may be required are shown in Figures 3, 5 and 6.

15

With reference to Figure 4, to more efficiently reflect light emitted from the vessel 2 or to focus it differently from the focus pattern dictated by the walls of the cavity 4, one or more separate reflectors 12 may be mounted in the cavity 4. A typical material for a UV and microwave embodiment is PTFE-based material. The material should be transmissive to the rf energy to allow it to impinge on the vessel 2 and should be reflective to the light emitted by the vessel 2 as shown generally by the arrow A.

20

Figure 5 shows a vessel which is recessed into the cavity 4. This allows products to be placed into the recess which may allow greater coverage of the product without requiring additional reflectors or additional light emitting apparatus to be used.

25

Figure 6 shows a generally tubular vessel 2 interconnecting two walls of the cavity 4. This allows material to be passed through the vessel 2 as shown generally by the arrows B. This is particularly convenient for irradiating or sterilising continuous materials or continuous flows.

30

Figures 7A and 7B show alternative arrangements for the interface between the vessel 2 and the conductive walls of the cavity 4. Each of these arrangements will be effective where the aperture defined by the sides of the cavity 4 is not beyond cut off.

- 5 Figures 8A and 8B show quarterwave choke arrangements for use to minimise rf leakage where the aperture defined by the cavity walls 4 is beyond cut off at the rf wavelength used.

10 Thus in summary, all the embodiments described above allow products to be irradiated with light typically ultraviolet light whilst being largely protected from the effects of the rf (typically microwave) energy source. This will have wide application both in the UV field where curing and sterilisation applications proliferate and also in any field where energised plasma light sources produce light in desirable wavelengths.

CLAIMS

1. Apparatus for emitting light at one or more predetermined wavelengths comprising an rf resonant cavity couplable to a source of rf energy of a predetermined wavelength, at least part of the cavity wall having a window constructed from a light transmissive material formed into a hollow vessel, the vessel containing a fill material which in use, emits light at the predetermined one or more wavelengths when energised by rf energy of the predetermined wavelength.
2. Apparatus according to claim 1. including an electrically conductive rod extending generally from the rf coupling into the cavity.
3. Apparatus according to claim 1 or claim 2, wherein at least part of the cavity wall is constructed and arranged as a reflector to direct light which is emitted from the window into the cavity back out of the cavity through the window.
4. Apparatus according to any preceding claim, including a reflector mounted in the cavity constructed and arranged to direct light emitted from the window into the cavity back out of the window.
5. Apparatus according to claim 3 or claim 4, wherein the reflector is a focussing reflector.
6. Apparatus according to any preceding claim, wherein the window forms a recess into the cavity.
7. Apparatus according to any of claims 1 to 5, wherein the window is generally planar.
8. Apparatus according to any of claims 1 to 5, wherein the window is generally tubular and interconnects two faces of the cavity.
9. Apparatus according to any of claims 1 to 8, wherein the window forms an outwardly

curving wall of the cavity.

10. Apparatus for emitting light constructed and arranged as described herein with reference to the drawings.

**Amendments to the claims have been filed as follows**

1. Apparatus for radiating energy at one or more predetermined wavelength comprising, a housing, a source of microwave energy coupled to and located outside the housing and  
5 a window forming part of the wall of the housing, the window being formed from a material which is substantially transparent to radiation at the or each predetermined wavelength and at the wavelength of the microwave source, the window including gas of a predetermined composition at a predetermined pressure contained in a gas-tight enclosure defined by the window material, the gas composition being chosen to emit  
10 energy at the or each predetermined wavelength in response to microwave energy from the housing impinging generally on an inner surface of the window, the window being arranged substantially to be opaque at the wavelength of the microwave energy and being arranged to provide an unobstructed radiating path from its outer surface for the energy of the or each predetermined wavelength.
- 15 2. Apparatus according to claim 1, wherein the window material is generally homogenous.
3. Apparatus according to claim 1 or claim 2, including an electrically conductive rod extending generally from the microwave source into the housing.
- 20 4. Apparatus according to any preceding claim, wherein at least part of the housing wall is constructed and arranged as a reflector to direct light which is emitted from the window into the housing back out of the housing through the window.
- 25 5. Apparatus according to any preceding claim, including a reflector mounted in the housing constructed and arranged to direct light emitted from the window into the housing back out of the window.
6. Apparatus according to claim 4 or claim 5, wherein the reflector is a focussing reflector.
- 30 7. Apparatus according to any preceding claim, wherein the window forms a recess into the housing.

8. Apparatus according to any of claims 1 to 6, wherein the window is generally planar.
9. Apparatus according to any of claims 1 to 6, wherein the window is generally tubular and interconnects two faces of the housing whereby material may be passed through the housing via the window.
10. Apparatus according to any of claims 1 to 9, wherein the window forms an outwardly directed wall of the housing.
11. Apparatus according to any preceding claim, wherein the housing incorporates only one window.
12. Apparatus according to any preceding claim, wherein the energy radiated from the window is in the ultraviolet wavelength range.
13. Apparatus for radiating energy constructed and arranged as described herein with reference to the drawings.

Application No: GB 9807844.7  
Claims searched: all

Examiner: Martyn Dixon  
Date of search: 15 July 1998

### Patents Act 1977 Search Report under Section 17

#### Databases searched:

UK Patent Office collections, including GB, EP, WO & US patent specifications, in:

UK Cl (Ed.P): H1D (DBT4)

Int Cl (Ed.6): H01J (65/00,65/04); A61L (2/10); B65B (55/08,55/16)

Other: Online: WPI, JAPIO

#### Documents considered to be relevant:

Category	Identity of document and relevant passage	Relevant to claims
X	GB 2307097 A (Jenton) see page 6, lines 15-17	1
X	US 4063132 A (GTE) the whole document	1,2,7
X	Patent Abstracts of Japan, Vol 17, No 375 [E-1397] & JP050062649A (Rikagaku Kenkyusho)	1,6,7

X	Document indicating lack of novelty or inventive step	A	Document indicating technological background and/or state of the art.
Y	Document indicating lack of inventive step if combined with one or more other documents of same category.	P	Document published on or after the declared priority date but before the filing date of this invention.
&	Member of the same patent family	E	Patent document published on or after, but with priority date earlier than, the filing date of this application.