

3<sup>d</sup> Sheet of 5<sup>th</sup> Sheet 1.

*C. W. Wettengel,*  
*Horseshoe Machine.*

*N<sup>o</sup> 100,574.*

*Patented Mar. 8, 1870.*

*Fig. 1.*

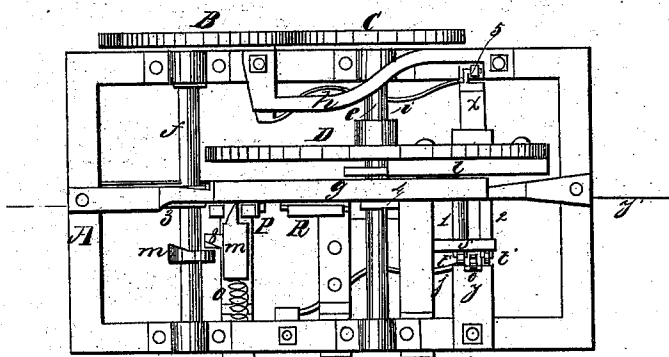

*Fig. 2.*

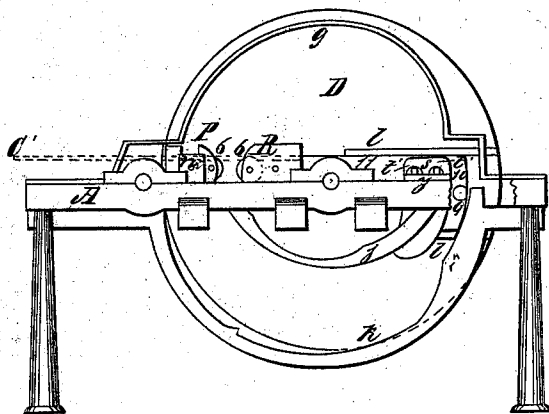

*Witnesses:*  
*Samuel Johnston*  
*A. C. Johnston*

*Inventor:*  
*Charles W. Wettengel*

C. W. Wetengel,  
Horseshoe Machine.

No 100,574.

Patented Mar. 8, 1870.

Fig: 3.

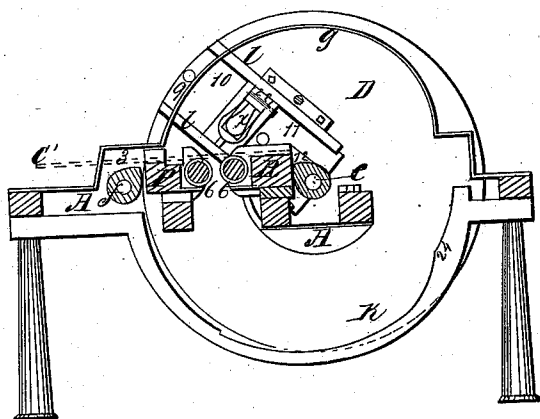
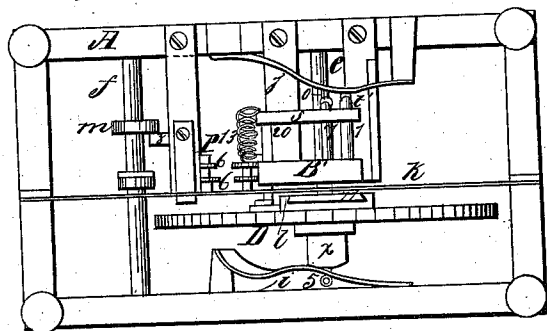
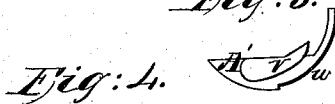

Fig: 5.



Witnesses:  
James J. Johnston  
A. C. Johnston

Inventor:  
Charles W. Wetengel

35 Sheets, Sheet 3.

*C. W. Wetengel,*  
*Horseshoe Machine.*

*N<sup>o</sup> 100,574.*

*Patented Mar. 8, 1870.*

*Fig: 6.*

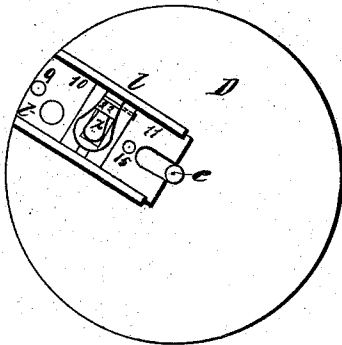

*Fig: 7.*

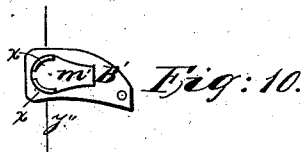
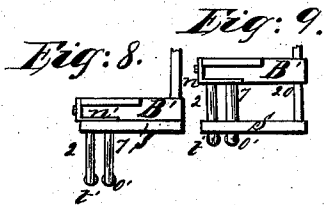
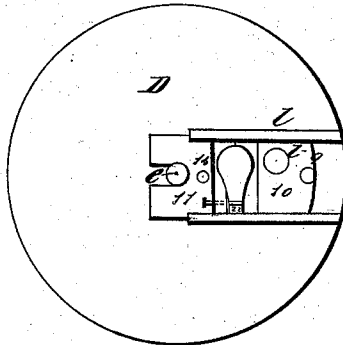

*Fig: 11.*

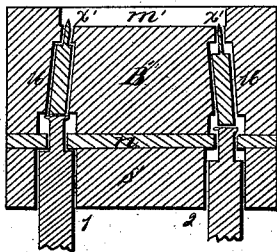

*Witnesses:*  
*James L. Johnston*  
*A. C. Johnson*

*Inventor:*  
*Charles W. Wetengel*

# United States Patent Office.

CHARLES W. WETTENGEL, OF PITTSBURG, PENNSYLVANIA.

Letters Patent No. 100,574, dated March 8, 1870.

## IMPROVED MACHINE FOR MAKING HORSESHOES.

The Schedule referred to in these Letters Patent and making part of the same.

### To all whom it may concern:

Be it known that I, CHARLES W. WETTENGEL, of the city of Pittsburg, in the county of Allegheny, and State of Pennsylvania, have invented a new and useful Improvement in Horseshoe-Machines; and I do hereby declare that the following is a full, clear, and exact description thereof, reference being had to the accompanying drawings, and to the letters and figures of reference marked thereon.

The nature of my invention consists in the combination and arrangement of a disk, dies, plates, guides, cams, and grooving-tools, combined, arranged, and operating with relation to each other, in the manner hereinafter described, for the purpose of forming horseshoes.

To enable others skilled in the art to make and use my invention, I will proceed to describe more fully its construction and operation.

In the accompanying drawings, which form part of my specification—

Figure 1, Sheet A, is a top view or plan of my improvement in horseshoe-machines.

Figure 2 is a side elevation of the same.

Figure 3, Sheet B, is a vertical and longitudinal section of the machine when cut through at line *y'* of fig. 1.

Figure 4 is an inverted view of the machine.

Figure 5 is a face view of a cam or guide for operating one of the plates on the disk.

Figures 6 and 7, Sheet C, are face views of the disk, representing the plates in different positions with relation to the die for forming the opening of the horseshoe.

Figures 8 and 9 are top or side views of the clamping-die and grooving-tools, representing the parts in different positions.

Figure 10 is a face view of the same.

Figure 11 is a transverse section of the same when cut through at line *y'* of fig. 10, representing the several parts enlarged.

In the accompanying drawings—

A represents the frame of the machine.

B and C represent the driving-wheels, which are secured on the shafts *e* and *f*.

On the shaft *e* is secured a disk, D, in which is placed the die *x* for forming the opening in the horseshoe. To the face of the disk D is secured a guide, *z*, for the plates 10 and 11. From the face of the plate 10 projects a form, *t*, for giving the desired form to the upper surface of the shoe. From the face of the plates 10 and 11 project pins 9 and 15, which, in connection with the guides or cams *g*, *k*, and A', are used for imparting the desired motion to plates 10 and 11 during the revolving of the disk D.

The clamping-die and grooving-tools consisting of

the parts B', guide *s*, grooving-punches 16, which are provided with wedge-shaped points, as indicated at *x'*, and are secured in the part B' through the medium of plates *n'*. Against the end of the punches 16 rest the ends of levers 1 and 2, the outer ends of which are provided with small friction-rollers *t'*. The levers 1 and 2 are held in the desired position with relation to the punches 16 by means of plate *n'*, and the guide *s*, which is secured on the end of the bar 20 projecting from the face of the disk D.

The swaging-die B' is held in the desired position by the bar 20 and the guide-rod 7 projecting from the back of the part B'. The outer end of the guide-rod 7 is provided with a friction-roller, *o'*, and is used for moving the swaging-die B' up to its work. In the face of the clamping-die B' is a cavity, *m'*, corresponding to the form, size, and thickness of the shoe.

The outer end of the die *x*, which is used for forming the opening of the shoe, is provided with friction-roller 5, which, in connection with the guides or cams *h* and *i*, is used for giving the desired movements to the die *x*.

The sliding heads P and R are each provided with a grooved roller, 6, which are used for bending and forcing the iron for forming the shoe against the die *x*. The heads P and R move the rollers up to their work through the medium of the cams 3 and 12 on shafts *e* and *f*. (See fig. 3, Sheet B.)

The cutter *n* is forced up to its work by the cam *m* operating against projection 8 on it, and is drawn back through the medium of a coil spring, *o*. (See fig. 1, Sheet A.)

The desired movements are given to the clamping-die B' and its several parts by means of the guide or cam *j*, in combination with the guide-rod 7, levers 1 and 2, and the coil spring 13. (See fig. 4, Sheet B.)

The skilful mechanic, from the foregoing description and reference to the accompanying drawings, will readily understand the construction and arrangement of the several parts, and the relation they bear to each other. I will, therefore, proceed to describe their operation in forming a horseshoe.

By applying power to the wheel B, which gears into the wheel C, it will revolve the disk D. Iron of the desired thickness and width is fed into the machine by placing it in a groove made in the head pieces P and R, with the iron resting in the groove of the rollers 6, as indicated by the dotted lines C'. The revolving of the shaft *f* will cause the cam *m* to force the cutter *n* toward the face of the disk D and against the iron, and cut it off from the bar being fed into the machine. Soon as the iron is cut off, the cutter is drawn back by the action of the coil spring *o*.

The revolving of the disk D will have by this time forced out the die *x*, through the medium of the pul-

ley 5 moving along on the inner edge of the guide or cam *h*, and the pin 9 of the plate 10 moving on the upper surface of the guide or cam *g*, will bring the plates 10 and 11 into the position with relation to the die *x*, as shown in figs. 3 and 6; and the plate 10, in its movement through the medium of the rod 22, will draw plate 11 up with it. The die *x* at this point coming in contact with the iron for forming the shoe will bend it down in the grooves and between the rollers 6. At this point the cams 3 and 12 commence moving the heads P and R toward each other, so as to cause the grooved rollers 6 to press the iron closely to the die *x*, which die then passes down between the rollers 6, and carrying the iron with it, which will (by the form of the die *x*) remain on it.

At this point the pin 15 on plate 11 will enter the groove formed by the projections *v* and *w* on the guide or cam *A'*, and the pin 9 on the plate 10 will move along on the upper edge of the guide or cam *k*; and the movement of the pin 15 in guide or cam *A'*, and the movement of the pin 9 on the guide or cam *k*, will cause the plates 10 and 11 to close up against the die *x* and behind the formed shoe. The clamping-die B' will then be forced against the plates 10 and 11 by the roller *o'* of the guide-rod 7 pressing against the inside surface of the guide or cam J; and the shoe will be transferred from the die *x* to the clamping-die B', and will enter the cavity *m* of said clamping-die B'.

At this point the pin 9 on plate 10 will commence moving over the projection 24 of the guide or cam *k*, which will change the position of the plates 10 and 11, so as to bring the projection *t* on the plate 10 opposite to the shoe in the recess *m'* of the clamping-die B', at

which point the rollers *t'* of the levers 1 and 2 will commence moving upon the incline Y, and force the levers against the end of the punches 16, and cause their wedge-shaped points *x'* to be forced into the shoe while it is in the cavity *m'* of the die B'; and as soon as the roller *o'* of the guide-rod 7 has passed the incline Y, the spring 13 will cause the die B' to fly back against the guide *s*, and thereby jar the shoe out of the cavity *m'* of die B', allowing it to drop from the machine a perfectly-formed and grooved shoe.

It will be observed by reference to fig. 11, Sheet C, that the punches 16 are inclined for giving the desired angle to the groove in the shoe.

Having thus described the nature, construction, and operation of my improvement,

What I claim as of my invention, is—

1. The combination and arrangement of the disk D, plates 10 and 11, guides or cams *g h i J k*, head pieces P and R, provided with grooved rollers 6, cams 3, 12, and *m*, cutter *n*, and die *x*, the several parts being constructed, combined, arranged, and operating with relation to each other substantially as herein described, and for the purpose set forth.

2. The revolving clamping-die B' provided with inclined grooving-tools 16, in combination with the revolving die *x* and projection *t*, arranged to operate conjointly substantially as herein described, and for the purpose set forth.

CHARLES W. WETTENGEL.

Witnesses:

A. C. JOHNSTON,  
JAS. G. THOMPSON.