



(12) APPLICATION

(11) 20171962

(13) A1

NORWAY

(19) NO

(51) Int Cl.

E04H 12/22 (2006.01)

E02D 27/42 (2006.01)

E04H 12/22 (2006.01)

Norwegian Industrial Property Office

(21)	Application nr	20171962	(86)	Int. application day and application nr
(22)	Application day	2017.12.08	(85)	Entry into national phase
(24)	Date from which the industrial right has effect	2017.12.08	(30)	Priority
(41)	Available to the public	2019.06.10		
(71)	Applicant	COMROD AS, Fiskåvegen 1, 4120 TAU, Norge		
(72)	Inventor	Ole Gunnar Fjelde, Nagavegen 54, 4120 TAU, Norge		
(74)	Agent or Attorney	HÅMSØ PATENTBYRÅ AS, Postboks 171, 4301 SANDNES, Norge		

(54) Title **Method for fixing a conical energy transportation mast to the ground.**
(57) Abstract

The invention relates to a method of fixing an energy transportation mast (10) to the ground (100). The method comprises steps of: i) providing the energy transportation mast (10) having a bottom end portion (10b) being hollow and having a conical-shape; ii) forming a cylindrical slit (110) in the ground (100), wherein a width (ws) of the cylindrical slit (110) is larger than a width of sidewalls (10sw) of the bottom end portion (10b) of the mast (10); iii) placing the energy transportation mast (10) with its bottom end (10b) in the cylindrical slit (110), and iv) filling a volume between the sidewalls (10sw) of the mast (10) and an outer circumference (110cf) of the slit (110) with material (99)) for fixing the mast (10) to the ground (100). In an alternative method the mast is placed on a hollow conical-shaped adaptor module (20) that is directly placed into the slit (110) instead of the mast (10).

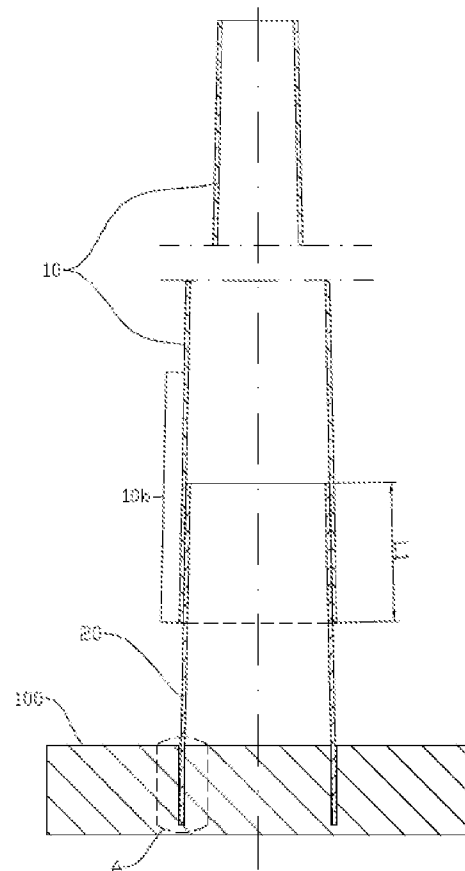

METHOD FOR FIXING A CONICAL ENERGY TRANSPORTATION MAST TO THE GROUND

FIELD OF THE INVENTION

5 The invention relates to a method of fixing an energy transportation mast to the ground.

BACKGROUND OF THE INVENTION

It is known to fasten composite poles in the ground by excavating a recess, and thereafter positioning the composite pole in the recess and fill in around the pole. Regarding poles
10 for overhead power lines, such a method will often involve relatively large environmental damage, particularly when a recess is made in rock. When fastening poles by use of said method, frost damage may occur due insufficient draining.

It is also known to mount a composite pole to a column raised from the ground. The column may be made from concrete and having reinforcement that extends into the ground.
15 The composite pole may be inserted over the column. If the column is made from concrete, it is necessary to bring the concrete to the position of the column often by use of a helicopter, or make concrete at the position of the column. Both methods comprise extra costs and work.

WO2004/101914 discloses a hollow pole that is drilled into a slit the ground. Documents
20 EP1911912A2, WO2004/101914A1, GB2444411 and GB2429229A show other solutions from the prior art.

Patent application publication WO2017/142419A1, owned by the same applicant as the current application, discloses a method and apparatus for fastening a composite pole to the ground, wherein a slit-formed opening is drilled in the ground, after which a fastening

element is placed in the slit-formed opening. Subsequently the composite mast is placed over the fastening element. This known method forms a very convenient, cost-efficient way of fastening composite poles (energy transportation masts) to the ground, when compared with the earlier mentioned methods. Still there is a need to further develop methods for fixing energy transportation masts to the ground, in particular conical-shaped energy transportation masts made of one-piece in composite material.

SUMMARY OF THE INVENTION

The invention has for its object to remedy or to reduce at least one of the drawbacks of the prior art, or at least provide a useful alternative to prior art.

The object is achieved through features, which are specified in the description below and in the claims that follow.

The invention is defined by the independent patent claims. The dependent claims define advantageous embodiments of the invention.

In a first aspect the invention relates to a method of fixing (or fastening) an energy transportation mast to the ground. The method comprises steps of:

- providing the energy transportation mast having a bottom end portion being hollow and having a conical-shape;
- forming a cylindrical slit in the ground, wherein a width of the cylindrical slit is larger than a width of sidewalls of the bottom end portion of the mast.
- placing the energy transportation mast with its bottom end in the cylindrical slit, and
- filling a volume between the sidewalls of the mast and an outer circumference of the slit with material for fixing the mast to the ground.

In a second aspect the invention relates to a method of fixing (or fastening) an energy transportation mast to the ground. The method comprises steps of:

- providing the energy transportation mast having a bottom end portion being hollow and having a conical-shape;
- providing an adapter module having a bottom end portion being hollow and having a conical-shape;
- forming a cylindrical slit in the ground, wherein a width of the cylindrical slit is larger than a width of sidewalls of the bottom end portion of the adapter module;

- placing the adaptor module with its bottom end portion in the cylindrical slit;
- placing the energy transportation mast with its bottom end portion over the adapter module such that it overlaps with a predefined length, and
- filling a volume between the sidewalls of the adapter module and an outer circumference of the slit with material for fixing the adapter module (and thereby also the mast) to the ground.

The effects of the methods in accordance with the first and second aspect of the invention are as follows. By drilling a wider cylindrical slit in the ground than width of the sidewalls of the hollow adapter element (or mast) to be placed therein, this opens up the possibility to place a conical-shaped hollow adapter element (or mast), even when the slit is cylindrical in shape. Then, after that the conical-shaped hollow adapter element (or mast) is placed in the slit, the slit is filled from the upper side with the material, which then presses on the conical-shaped hollow adapter element or mast, whichever embodiment applies, and keeping it in place. The method thus results in a simple yet effective method of fixing an energy transportation mast to the ground. More details with regards to these advantageous effects are given in the detailed description of the figures.

In order to facilitate understanding of the invention one or more expressions are further defined hereinafter.

Wherever the wording "mast" is used, this is to be seen as equivalent to words like tower, pylon, and pole.

In an embodiment of the method in accordance with the invention, in the step of providing the energy transportation mast, the bottom end portion of the mast has a first conicity value that is between 0,5 and 40 millimeters per meter length and preferably between 1 and 10 millimeters per meter length. The advantage of choosing this conicity value is that it provides for a convenient balance between 1) required slit width, 2) obtained mast height on one side, and 3) robustness. The higher the conical value, the wider the slit must be, but also the lower the mast height will be. The lower the conical value the narrower the slit can be, but also the smaller the holding effect of the mast into the slit, i.e. it will lead to a smaller volume to put drill debris/sand in.

In an embodiment of the method in accordance with the invention, in the step of providing the adapter module, the bottom end portion of the adapter module has a further conicity value that is between 0,5 and 40 millimeters per meter length and preferably between 1 and 10 millimeters per meter length. The advantage of choosing this conicity value is that

it provides for a convenient balance between 1) required slit width, 2) obtained mast height on one side, and 3) robustness. The higher the conical value, the wider the slit must be, but also the lower the mast height will be. The lower the conical value the narrower the slit can be, but also the smaller the holding effect of the mast into the slit, i.e. less volume to put drill debris/sand in.

In an embodiment of the method in accordance with the invention, the step of forming a cylindrical slit is carried out with a cylindrical drill tool. A possible implementation of such drill tool is shown in WO2017/142419A1. The current invention in this embodiment may effectively reuse the drill debris that is formed during the drilling. This debris is to be put in the cylindrical slit after that the conical mast of adaptor module have been placed in the slit.

In an embodiment of the method in accordance with the invention, in the step of filling the volume, the material is selected from a group consisting of: a cement slurry, a resin or any other suitable consolidating material. The advantage of this embodiment is that the mast or adaptor module is fixed firmly in the ground and will not be easily taken out anymore.

The material may be some sort of curing material such as grouting compound or concrete. An advantage of using a (curing) slurry or (fluid) resin is that it may be difficult and time consuming to get dry substances into the slit. An example of a suitable resin is epoxy based grouting compound.

In a further embodiment of the method in accordance with the invention, in the step of filling the volume, the material also comprises sand and/or drill debris that was formed and collected during the forming of the slit. In this embodiment the drill debris and/or sand that was obtained during the forming of the cylindrical slit is advantageously reused and put back in the slit, pressing on the conical-shaped hollow adapter element (or mast) and keeping it in place. Drill debris is very fine. When dried it will have the form of powder. It can also be easily mixed with any curing or setting slurry.

BRIEF INTRODUCTION OF THE DRAWINGS

In the following is described an example of a preferred embodiment illustrated in the accompanying drawings, wherein:

Fig. 1 illustrates a final stage of a first embodiment of the method of fixing an energy transportation mast to the ground;

Figs. 2-5 illustrate earlier stages of the same method, and

Fig. 6 illustrates a final stage of a second embodiment of the method of fixing an energy transportation mast to the ground.

DETAILED DESCRIPTION OF THE EMBODIMENTS

Various illustrative embodiments of the present subject matter are described below. In the interest of clarity, not all features of an actual implementation are described in this specification. It will of course be appreciated that in the development of any such actual embodiment, numerous implementation-specific decisions must be made to achieve the developers' specific goals, such as compliance with system-related and business-related constraints, which will vary from one implementation to another. Moreover, it will be appreciated that such a development effort might be complex and time-consuming, but would nevertheless be a routine undertaking for those of ordinary skill in the art having the benefit of this disclosure.

The present subject matter will now be described with reference to the attached figures. Various systems, structures and devices are schematically depicted in the drawings for purposes of explanation only and so as to not obscure the present disclosure with details that are well known to those skilled in the art. Nevertheless, the attached drawings are included to describe and explain illustrative examples of the present disclosure. The words and phrases used herein should be understood and interpreted to have a meaning consistent with the understanding of those words and phrases by those skilled in the relevant art. No special definition of a term or phrase, i.e., a definition that is different from the ordinary and customary meaning as understood by those skilled in the art, is intended to be implied by consistent usage of the term or phrase herein. To the extent that a term or phrase is intended to have a special meaning, i.e., a meaning other than that understood by skilled artisans, such a special definition will be expressly set forth in the specification in a definitional manner that directly and unequivocally provides the special definition for the term or phrase.

Fig. 1 illustrates a final stage of a first embodiment of the method of fixing an energy transportation mast 10 to the ground 100. The figure shows a conical-shaped hollow mast

10 that is placed with its end portion 10b over a hollow adapter module 20, wherein the adapter module 20 is placed in the ground 100. As can be seen the mast 10 overlaps with the adapter module 20 over a specific length L1. This overlap length L1 may be set by shaping the adapter module 20 and the end portion of the mast 10. The length must be chosen such that enough mechanical strength is obtained. It must be stressed that the conicity of the part of the end portion 10b of the mast 10 that is inserted in the ground 100 may be different from the conicity of the rest of the mast 10. The conicity of the end portion 10b of the mast may be between 0,5 mm and 40 mm per meter length in an embodiment of the invention, and preferably between 1 mm and 10 mm per meter length.

10 Figs. 2-5 illustrate earlier stages of the same method. Fig 2. shows an enlarged view of part A of Fig. 1, at a stage of the method before the adapter module 20 is placed in the ground 100. It is shown in this figure that a (cylindrical) slit 110 is formed having a depth d_s and a width w_s . Such slit 110 may be formed using a cylindrical drill tool as shown in WO2017/142419A1. A typical depth d_s of the slit lies in the range from 40 cm to 400 cm. In good quality rock, typical depths are between 60 cm and 120 cm. In soil the depth is governed by reaching a frost-safe depth and having sufficient surface area towards the soil in order to carry the bending moments induced by for instance wind load on the mast. A typical width w_s of the slit 110 lies in the range of 6 mm to 50 mm. Fig. 2 in juxtaposition with Figs. 1 and 3 also illustrates what is meant with the term "outer circumference 110cf" of the slit 110, which is mentioned in the claims.

In a next stage of the method a hollow conical-shaped adapter module 20 is placed in the slit 110. This is shown in Fig. 3. In this figure it is also illustrated that a sidewall 20sw of the adapter module 20 has a thickness t_w that is smaller than the width w_s of the slit 110 as illustrated in Fig. 2. A typical range for the thickness t_w of the sidewall 20sw lies between 4 mm and 40 mm, and typically between 6 mm and 25 mm dependent on the height of the mast 10 and the expected forces on the mast 10. The consequence is that a bottom end portion of the adapter module 20 can be conical-shaped even if the slit 110 is 100% cylindrical. The figure illustrates that the sidewall 20sw makes a (small) angle with the slit 110.

30 In Fig. 4 a further stage of the method is illustrated. In this stage material 99 is put into the slit 110 as illustrated. This material 99 presses on the sidewall 20sw of the adapter module 20. Cement, resin or any other suitable consolidating material may be used or added to the sand and/or debris 99 to obtain a firm mass that holds the adapter module 20 in the

slit 110. Water may need to be added to the mixture in order for consolidation and hardening to occur.

Fig. 5 shows the same stage of the method as Fig. 4. The figure serves to illustrate that it is at least important that an end portion 20b of the adapter module 20 is hollow and conical-shaped. It must be stressed that the conicity of the part of the end portion 20b of the adapter module 20 that is inserted in the ground 100 may be different from the conicity of the rest of the adapter module 20. The conicity of the end portion 20b of the adapter module 20 may be between 0,5 mm and 40 mm per meter length in an embodiment of the invention, and preferably between 1 mm and 10 mm per meter length.

Fig. 6 illustrates a final stage of a second embodiment of the method of fixing an energy transportation mast 10 to the ground 100. The second embodiment of the method shows great similarity with the first embodiment. The main difference between said embodiments is that the adapter module 20 is dispensed with. Instead the mast 10, which must have an end portion 10b that is hollow and conical-shaped, is placed directly in the slit 110, after which sand and/or drill debris 99 is put in the slit 110 as illustrated (optionally with added cement, resin or any other suitable consolidating material). Similar to Fig. 3 the sidewall 10sw of the mast in that case needs to have a thickness smaller than the width w_s (Fig. 2) of the slit 110.

As mentioned earlier the second section (upper section) 10-2 of the mast is configured for carrying and guiding electric cables. There are different ways of achieving this function for the mast 10.

A first way is to provide a crossbar (not shown) on the upper section of the mast 10. Such crossbar may be mounted to the upper section by means of a crossbar adapter (not shown). To this end the upper section may need to be configured for being able to receive the crossbar adapter. Subsequently, the electric cable (not shown) may be mounted to the crossbar via known fastening means (not shown).

A second way is to provide said fastening means directly to the upper section of the mast 10 and mount the electric cables thereto. In that case no crossbar or crossbar adapter is necessary.

The figures and description above do not disclose any details about a possible crossbar adapter to be placed on the mast, nor about the cross-bar or fastening means themselves. This knowledge is considered known to the person skilled in the art. Reference is made to

the non-prepublished patent application mentioned in the introductory part of this specification for more details.

The particular embodiments disclosed above are illustrative only, as the invention may be modified and practiced in different but equivalent manners apparent to those skilled in the art having the benefit of the teachings herein. For example, the method steps set forth
5 above may be performed in a different order. Furthermore, no limitations are intended to the details of construction or design herein shown, other than as described in the claims below. It is therefore evident that the particular embodiments disclosed above may be altered or modified and all such variations are considered within the scope of the inven-
10 tion. Accordingly, the protection sought herein is as set forth in the claims below.

It should be noted that the above-mentioned embodiments illustrate rather than limit the invention, and that those skilled in the art will be able to design many alternative embodi-
ments without departing from the scope of the appended claims. In the claims, any refer-
15 ence signs placed between parentheses shall not be construed as limiting the claim. Use of the verb "comprise" and its conjugations does not exclude the presence of elements or steps other than those stated in a claim. The article "a" or "an" preceding an element does not exclude the presence of a plurality of such elements. The mere fact that certain
measures are recited in mutually different dependent claims does not indicate that a com-
20 bination of these measures cannot be used to advantage. In the device claims enumerating several means, several of these means may be embodied by one and the same item of hardware.

C l a i m s

1. Method of fixing an energy transportation mast (10) to the ground (100),
c h a r a c t e r i s e d i n that the method comprises steps of:

- providing the energy transportation mast (10) having a bottom end portion (10b) being hollow and having a conical-shape;
- forming a cylindrical slit (110) in the ground (100), wherein a width (w_s) of the cylindrical slit (110) is larger than a width of sidewalls ($10sw$) of the bottom end portion (10b) of the mast (10);
- placing the energy transportation mast (10) with its bottom end (10b) in the cylindrical slit (110), and
- filling a volume between the sidewalls ($10sw$) of the mast (10) and an outer circumference ($110cf$) of the slit (110) with material (99) for fixing the mast (10) to the ground (100).

2. Method of fixing an energy transportation mast (10) to the ground (100),
c h a r a c t e r i s e d i n that the method comprises steps of:

- providing the energy transportation mast (10) having a bottom end portion (10b) being hollow and having a conical-shape;
- providing an adapter module (20) having a bottom end portion (20b) being hollow and having a conical-shape;
- forming a cylindrical slit (110) in the ground (100), wherein a width (w_s) of the cylindrical slit (110) is larger than a width of sidewalls ($20sw$) of the bottom end portion (20b) of the adapter module (20);
- placing the adaptor module (20) with its bottom end portion (20b) in the cylindrical slit (110);
- placing the energy transportation mast (10) with its bottom end portion (10b) over the adapter module (20) such that it overlaps with a predefined length (L_1), and
- filling a volume between the sidewalls ($20sw$) of the adapter module (20) and an outer circumference ($110cf$) of the slit (110) with material (99) for fixing the adapter module (20) to the ground (100).

3. The method according to claim 1 or 2, wherein, in the step of providing the energy transportation mast (10), the bottom end portion (10b) of the mast (10) has a first conicity value (α_1) that is between 0,5 and 40 millimeters per meter length, and preferably between 1 and 10 millimeters per meter length.

4. The method according to claim 2, wherein, in the step of providing the adapter module (20), the bottom end portion (20b) of the adapter module (20) has a further conicity value that is between 0,5 and 40 millimeters per meter length and preferably between 1 and 10 millimeters per meter length.
- 5 5. The method according to any one of the preceding claims, wherein the step of forming a cylindrical slit (110) is carried out with a cylindrical drill tool.
6. The method according to any one of the preceding claims, wherein, in the step of filling the volume, the material (99) is selected from a group consisting of: a cement slurry, a resin or any other consolidating material.
- 10 7. The method according to claim 6, wherein, in the step of filling the volume, the material (99) also comprises sand and/or drill debris that was formed and collected during the forming of the slit (110).

1/6

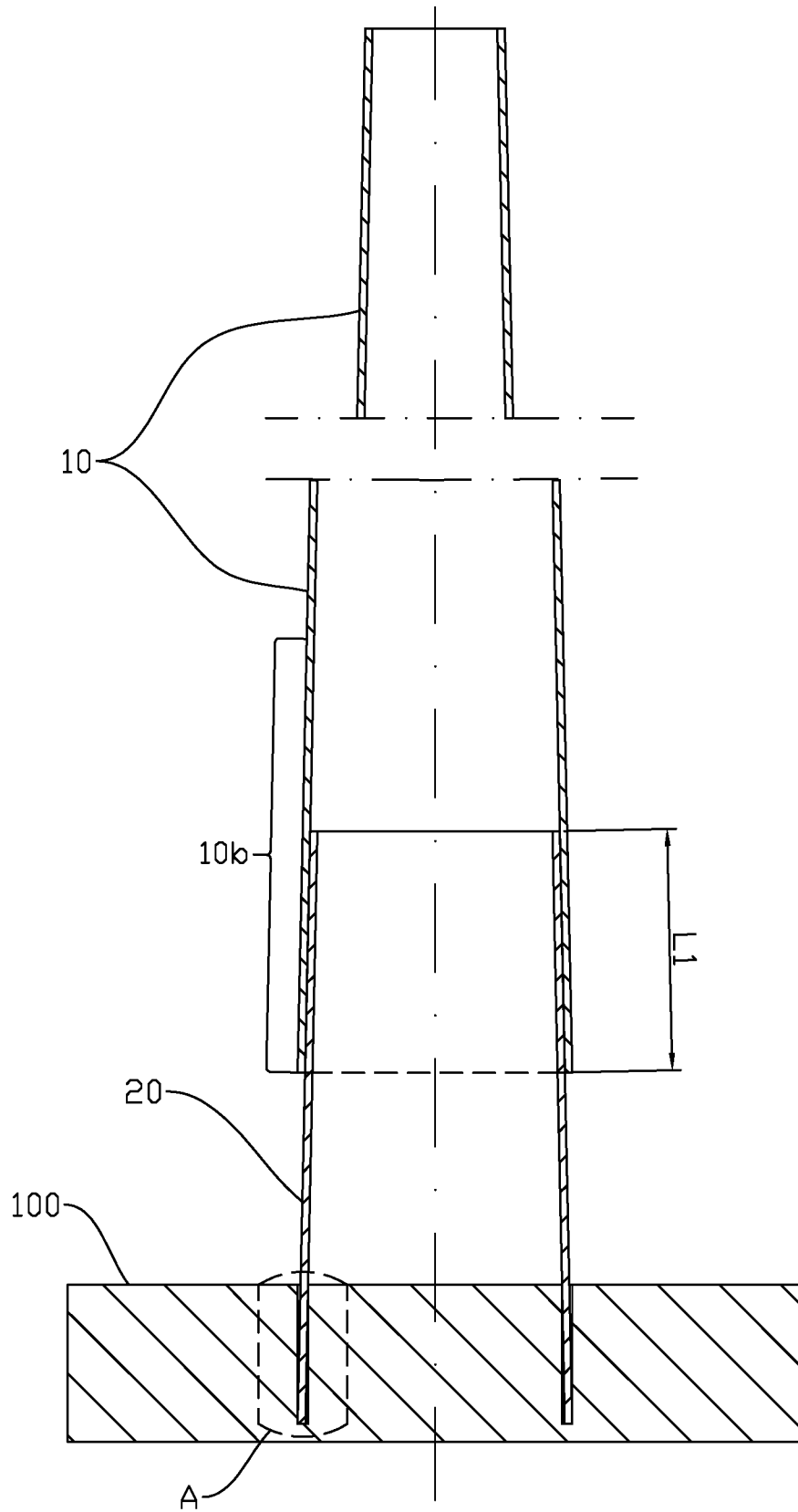

Fig. 1

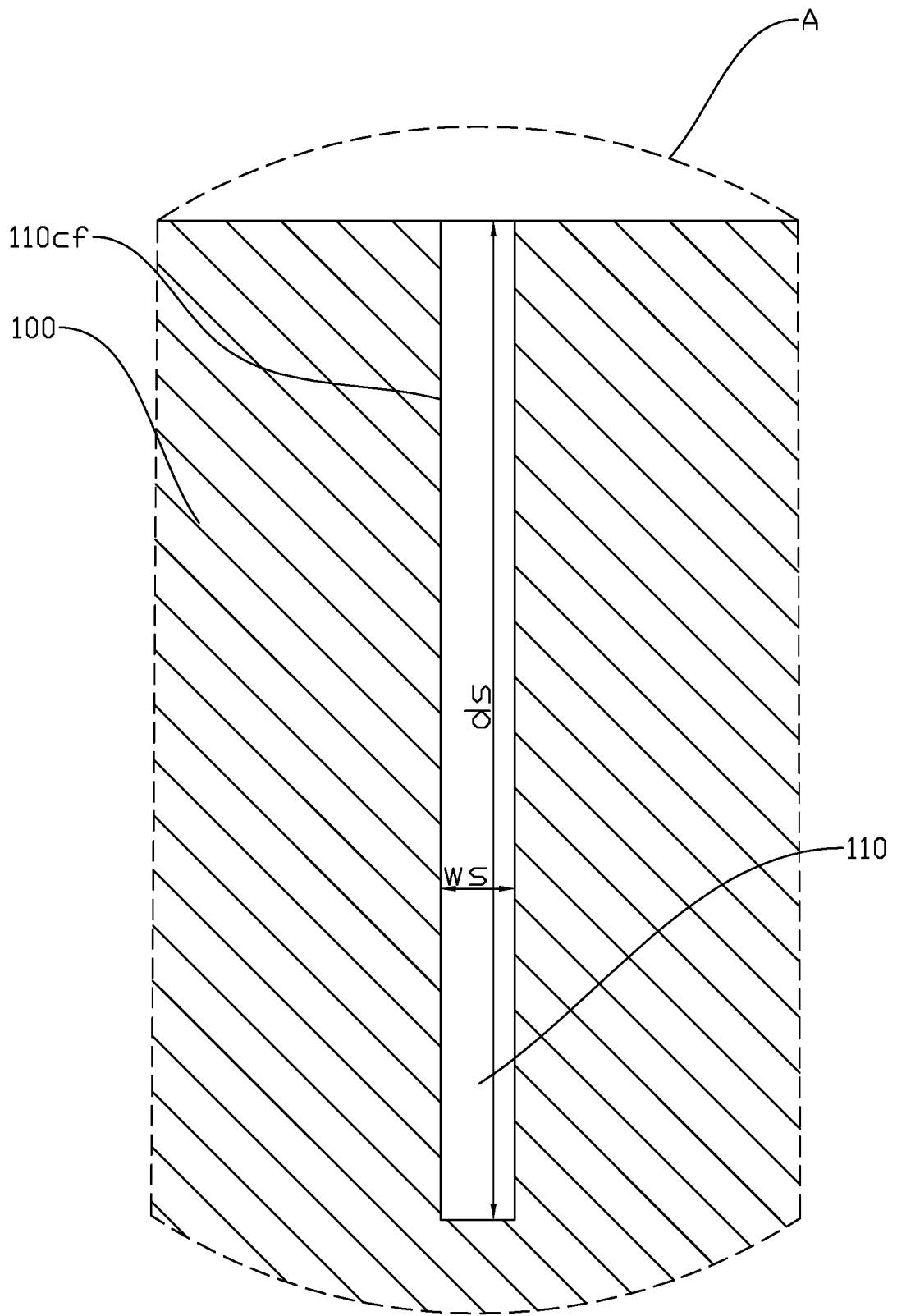

Fig. 2

3/6

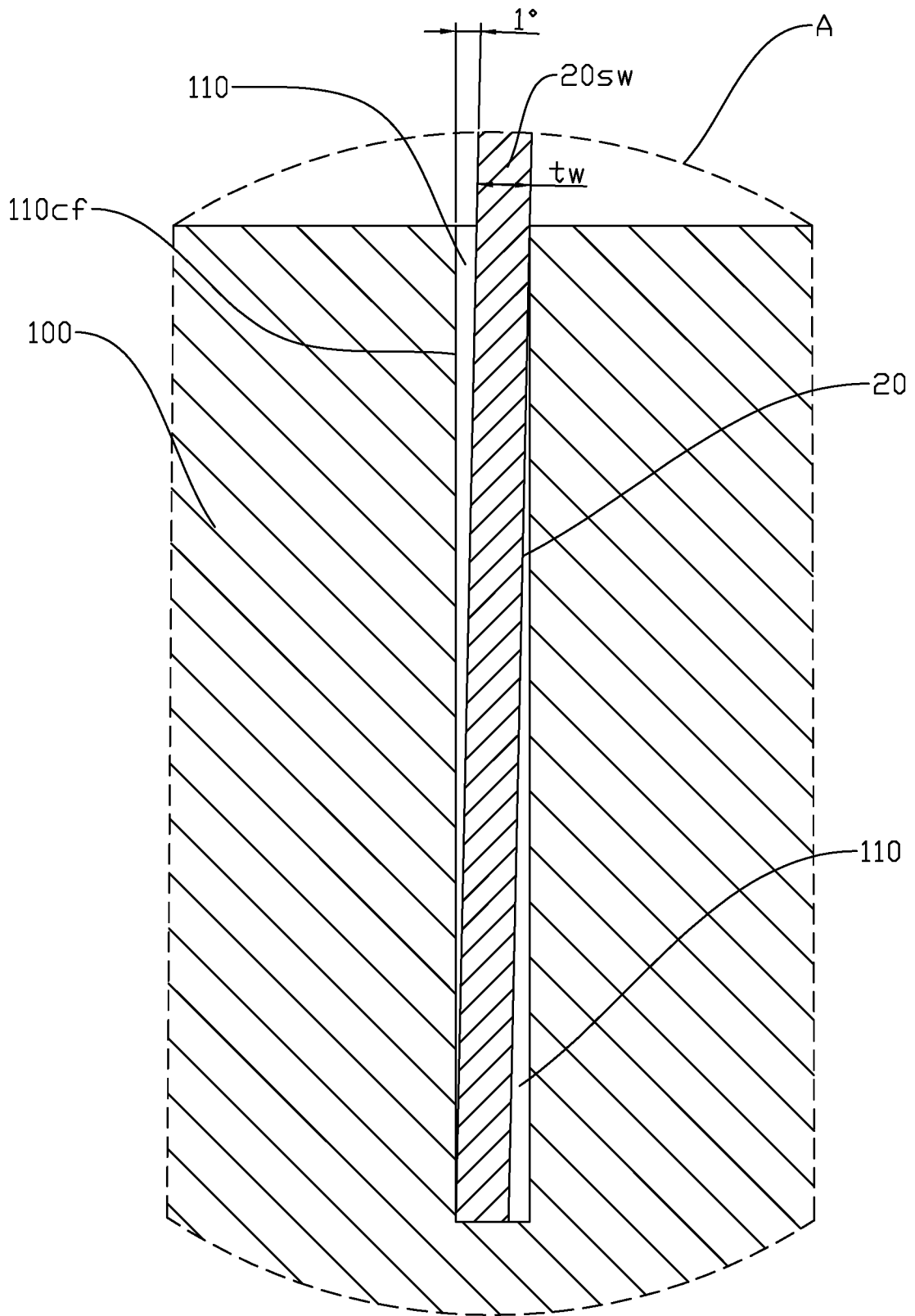

Fig. 3

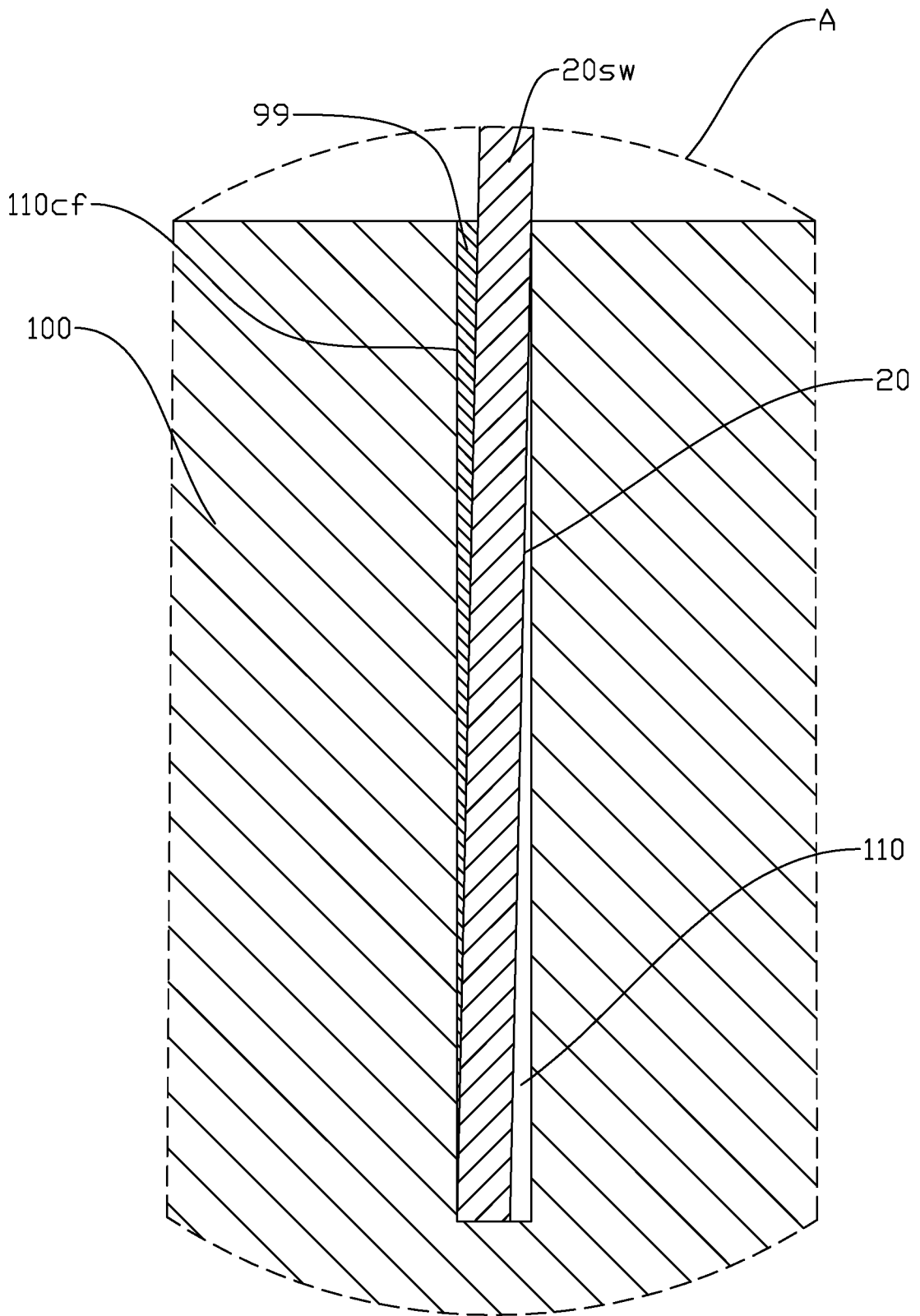

Fig. 4

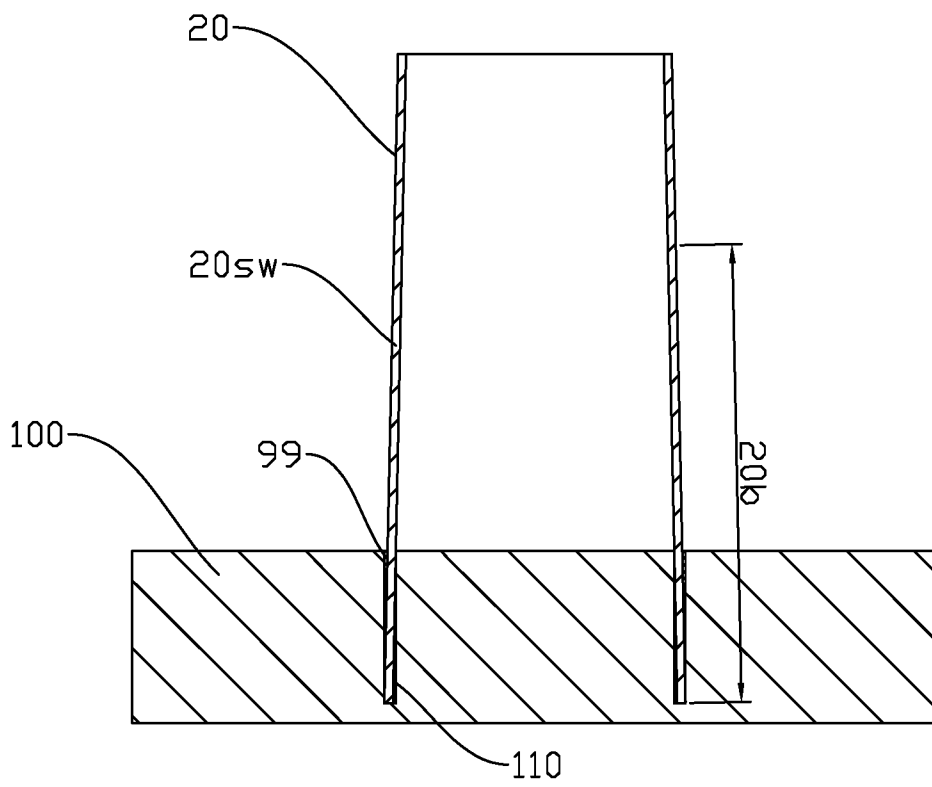

Fig. 5

6/6

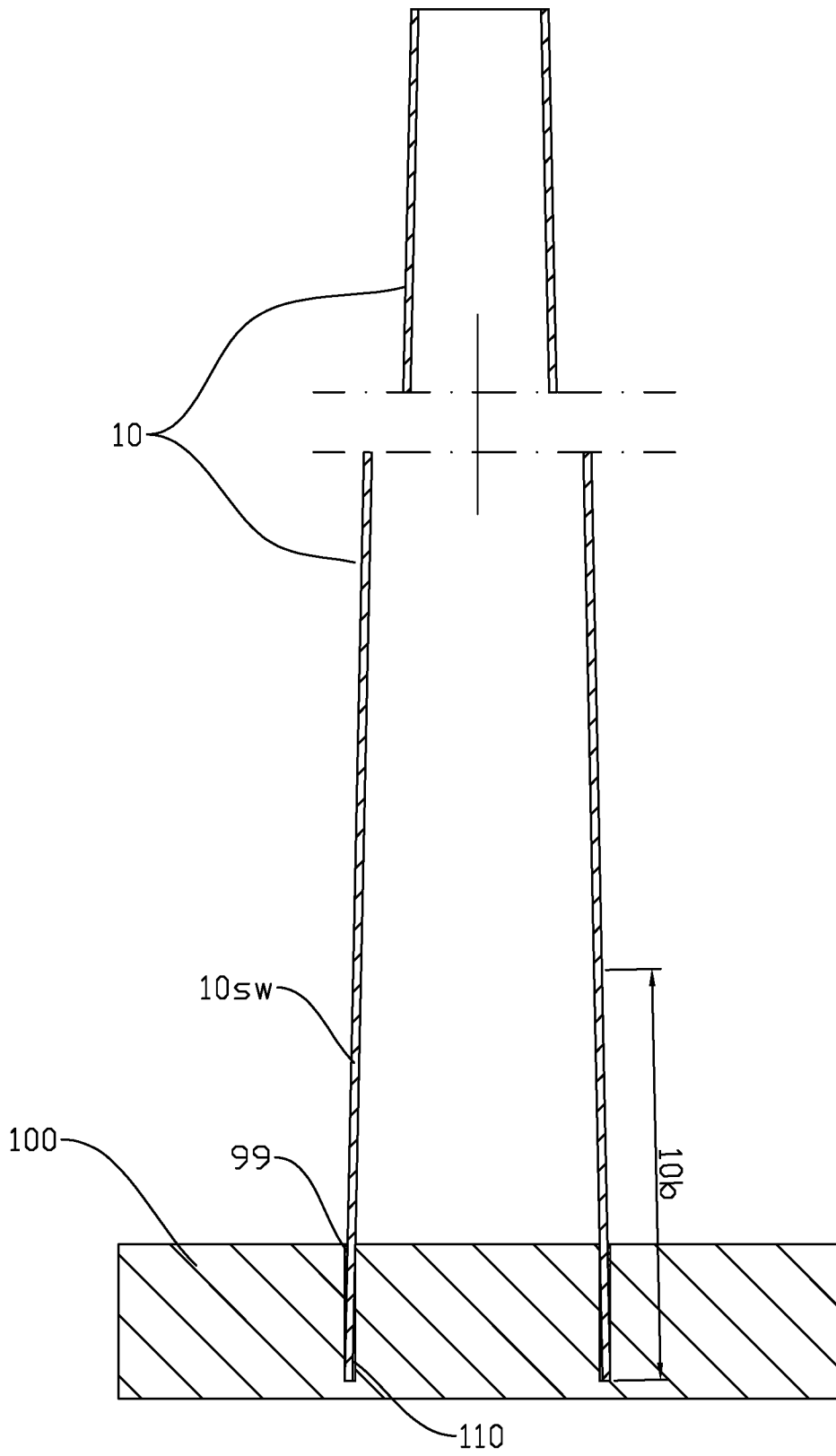

Fig. 6