

A. W. SCHOENLEBEN.
Flour Bolting-Machine.

No. 207,448.

Patented Aug. 27, 1878.

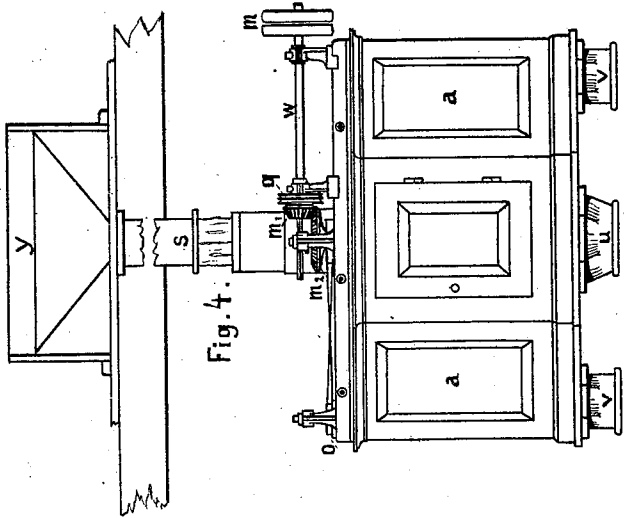

Fig. 4.

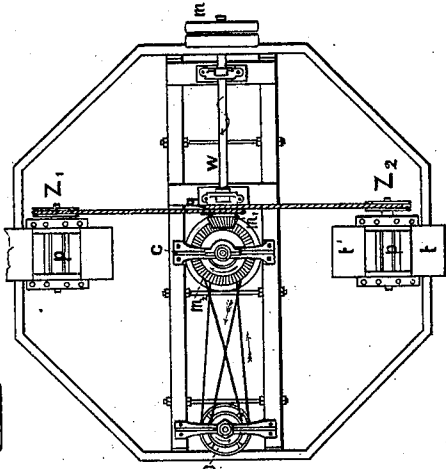

Fig. 3.

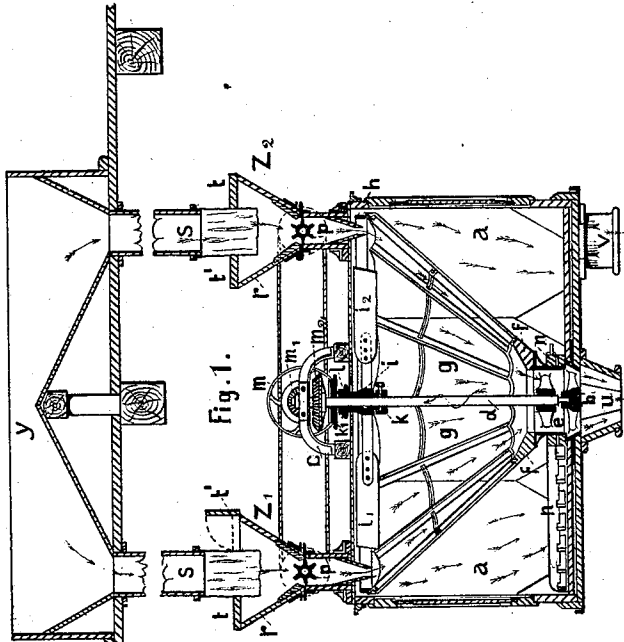

Fig. 1.

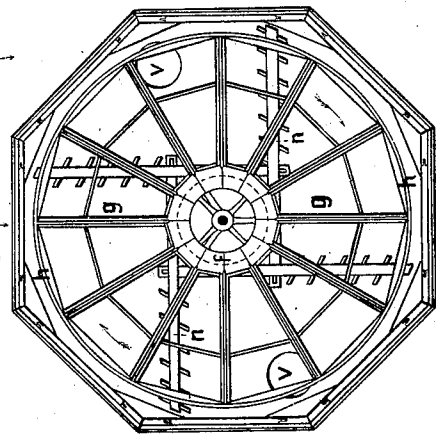

Fig. 2.

Attest,
Geo. H. Graham,
Edwin M. Donnelly,

Inventor,
A. W. Schoenleben,
by *Shuster & Philipp*
Attys.

UNITED STATES PATENT OFFICE.

ADOLPH W. SCHOENLEBEN, OF BITTERFELD, PRUSSIA.

IMPROVEMENT IN FLOUR-BOLTING MACHINES.

Specification forming part of Letters Patent No. 207,448, dated August 27, 1878; application filed April 30, 1878.

To all whom it may concern:

Be it known that I, ADOLPH WILHELM SCHOENLEBEN, of Bitterfeld, in the Kingdom of Prussia, have invented a Vertical Dressing-Machine for Flour and other Mills, of which the following is a specification:

The invention substantially consists in arranging the sifting-surface or the sifter proper in the shape of an inverted cone, and in causing the same to rotate on its vertical axis.

A sifting-machine of this kind is represented on the annexed sheet of drawings, Figure 1 being a vertical section through the feeding apparatuses; Fig. 2, a sectional plan; Fig. 3, a top view; and Fig. 4, an elevation corresponding to Fig. 3, with front feeding apparatus removed.

Within a casing, *a*, by preference of octagonal shape, a vertical shaft, *d*, revolves in the step *b'* and the bearing *c*, the former, *b'*, being connected by arms to a ring attached to the bottom of the casing, while the bearing *c* forms a bracket fixed to the top of the same.

e is a short hollow cylinder, cast in one piece with several arms and a boss, which is keyed to the lower end of the shaft *d*. The flange on the upper edge of the cylinder *e* carries a wooden ring, *f*, into which a number of wooden ledges are tenoned, radiating conically from this ring at a suitable angle to the axis, and connected at the top by the ring *h*. These parts thus constitute the frame-work of the sifter *g g*, having the shape of an inverted cone or polygonal pyramid. Into the spaces between the said ledges light wooden frames are inserted, to which the gauze or other sifting material is attached, the frames being held in their place by springs, turn-buckles, or other suitable devices.

The shaft *d* is driven by the bevel-wheels *m*₁ and *m*₂, the wheel *m*₁ being keyed on the main shaft *w*, which is provided with fixed and loose pulleys *m*.

On the shaft *d* a fan revolves loosely, consisting of the blades *i*₁, *i*₂, &c., attached to the arms of the boss *i*, this boss being supported by a ring, *k*, screwed to the shaft *d*. At the top the said boss is provided with a small pulley, *l*, which is driven from the pulley *k'* by means of straps and the counter-pulleys *o*, in the manner shown by Figs. 3 and 4, the

pulley *k'* being keyed to the shaft *d*. The fan thus rotates quickly in a direction contrary to the slow rotation of the sifter *g g*; but it may also rotate in the same sense. The blades of the fan are inclined in such a manner as to drive the air through the gauze, &c., of the sifter.

The material to be sifted is conducted from a hopper, *y*, through the tubes *s s* to the feeding apparatus *z*₁ *z*₂. Each of these consists of a small hopper or funnel, *r*, in the neck of which a grooved feed-roller, *p*, revolves, which is driven from a pulley, *q*, on the shaft *w*. The end of either tube *s* is, by preference, made of leather or cloth, and the top *t t'* of the funnel fits closely around this end; but the part *t'*, Figs. 1 and 3, can be opened for examining the interior of the apparatus.

The meal or other material to be sifted is thus continuously introduced at two opposite points of the sifter, and is equally distributed over the surface of the same while it rotates. The meal, &c., now sliding and rolling down on this surface, the finer parts either fall by their own weight through the meshes of the gauze, &c., or are driven through them by the action of the described fan, while the bran or other coarse parts pass out by the center opening *u*.

To the outside of the revolving cylinder *e* a number of arms, *n*, are fixed, provided with inclined plates or boards, thus forming rakes, which rake the flour collecting on the bottom of the casing toward the openings *v v*. At the same time these rakes mix the flour which has been separated at the top of the sifter with the comparatively coarser particles passing through the gauze near the lower end. The openings *v v* and *u* are provided on the outside of the casing with short tubes for attaching bags, as usual.

Instead of making the frame-work of the sifter *g g* of wood, it may be constructed of iron, and, according to the special purpose, silk, wire, or other gauze or perforated sheet metal may be applied.

The apparatus may be used for sifting meal, ground minerals, and colors, grain, and other materials.

The advantages to be attained by the described sifting apparatus are the following:

First, the material to be sifted is equally distributed over the whole sifting-surface. Consequently every part of the latter is utilized to the same extent, and the efficiency of the entire surface is increased.

Secondly, the material to be sifted is not thrown against the gauze, as is the case in centrifugal sifting-machines. The gauze is therefore less exposed to deterioration. Moreover, no beating arrangements are required.

Thirdly, the arrangement of the machine is simple. All its parts are easily accessible, and may therefore be examined with facility.

Fourthly, the flour is mixed within the casing of the machine.

I claim as my invention—

1. In a sifting-machine, the combination, with the conical or pyramidal sifter *g g*, fixed on a vertical rotating shaft, *d*, of a feeding device delivering the material at or near the circumference of said sifter, as and for the purpose described.

2. The fan consisting of the blades *i₁*, *i₂*, &c., and boss *i*, loosely rotating on the shaft *d*, in combination with the conical or pyramidal sifter *g g*, as described, and for the purpose specified.

3. The feeding apparatus *z₁* or *z₂*, having the grooved roller *p*, and arranged with the conical or pyramidal sifter *g g*, so as to deliver the material at or near the circumference thereof, substantially as specified, and for the purpose described.

4. The rakes *n n*, in combination with the inverted conical sifter *g g*, as and for the purpose set forth.

In testimony whereof I have signed my name to this specification in the presence of two subscribing witnesses.

ADOLPH WILHELM SCHOENLEBEN.

Witnesses:

PAUL KASTEN,
HCH. SPRINGMANN.