

(19) World Intellectual Property Organization
International Bureau



(43) International Publication Date
10 June 2010 (10.06.2010)

PCT

(10) International Publication Number
WO 2010/064986 A1

(51) International Patent Classification:
B65D 19/24 (2006.01)

(21) International Application Number:
PCT/SE2009/051369

(22) International Filing Date:
3 December 2009 (03.12.2009)

(25) Filing Language: Swedish

(26) Publication Language: English

(30) Priority Data:
0802525-6 4 December 2008 (04.12.2008) SE

(71) Applicant (for all designated States except US): IPG INTELLIGENT PACKAGING GROUP AB [SE/SE]; Industrivägen 1, S-302 41 Halmstad (SE).

(72) Inventor; and

(75) Inventor/Applicant (for US only): JOSEFSSON, Tobias [SE/SE]; Bondegatan 11, S-302 47 Halmstad (SE).

(74) Agent: VINK, Charlotta; Awapatent AB, P.O. Box 11394, S-404 28 Göteborg (SE).

(81) Designated States (unless otherwise indicated, for every kind of national protection available): AE, AG, AL, AM, AO, AT, AU, AZ, BA, BB, BG, BH, BR, BW, BY, BZ, CA, CH, CL, CN, CO, CR, CU, CZ, DE, DK, DM, DO, DZ, EC, EE, EG, ES, FI, GB, GD, GE, GH, GM, GT,

HN, HR, HU, ID, IL, IN, IS, JP, KE, KG, KM, KN, KP, KR, KZ, LA, LC, LK, LR, LS, LT, LU, LY, MA, MD, ME, MG, MK, MN, MW, MX, MY, MZ, NA, NG, NI, NO, NZ, OM, PE, PG, PH, PL, PT, RO, RS, RU, SC, SD, SE, SG, SK, SL, SM, ST, SV, SY, TJ, TM, TN, TR, TT, TZ, UA, UG, US, UZ, VC, VN, ZA, ZM, ZW.

(84) Designated States (unless otherwise indicated, for every kind of regional protection available): ARIPO (BW, GH, GM, KE, LS, MW, MZ, NA, SD, SL, SZ, TZ, UG, ZM, ZW), Eurasian (AM, AZ, BY, KG, KZ, MD, RU, TJ, TM), European (AT, BE, BG, CH, CY, CZ, DE, DK, EE, ES, FI, FR, GB, GR, HR, HU, IE, IS, IT, LT, LU, LV, MC, MK, MT, NL, NO, PL, PT, RO, SE, SI, SK, SM, TR), OAPI (BF, BJ, CF, CG, CI, CM, GA, GN, GQ, GW, ML, MR, NE, SN, TD, TG).

Declarations under Rule 4.17:

— as to applicant's entitlement to apply for and be granted a patent (Rule 4.17(ii))

Published:

— with international search report (Art. 21(3))
— before the expiration of the time limit for amending the claims and to be republished in the event of receipt of amendments (Rule 48.2(h))

(54) Title: STACKABLE PLASTIC PALLET AND A SYSTEM OF STACKABLE PLASTIC PALLETS

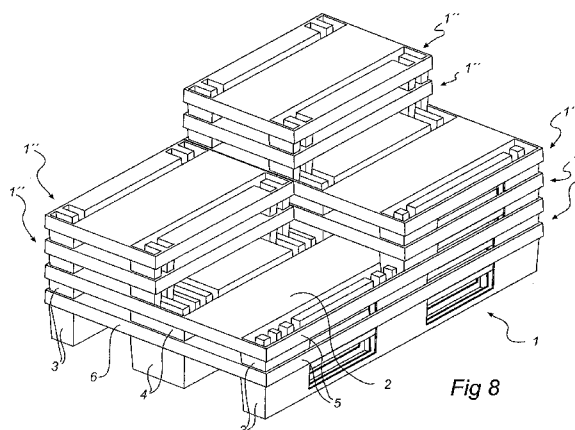

Fig 8

(57) Abstract: The present invention relates to a multiple-use pallet, comprising a load surface with two mutually perpendicular sides and at least two supporting legs for supporting the load surface, which supporting legs each have a supporting surface facing away from the load surface. The supporting legs are substantially parallel to each other and have an extent parallel to one of the two sides of the pallet. At least one of the supporting surfaces extends up to the load surface and forms part thereof. The invention further concerns a system of multiple-use pallets. The system comprises at least two multiple-use pallets, each pallet having two mutually perpendicular sides, which each have a certain length. The length of one side of the first pallet is a first integer multiple of the length of one side of the second pallet, and the length of the other side of the first pallet is a second integer multiple of the length of the other side of the second pallet. Any one of said first or said second integer multiple is different from one (1). The pallets are stackable in one another.



WO 2010/064986 A1

Stackable plastic pallet and a system of stackable plastic pallets

Technical Field

The present invention relates to a multiple-use pallet, comprising a load surface with two mutually perpendicular sides and at least two supporting legs for supporting the load surface, which supporting legs each have a supporting surface facing away from the load surface, the supporting legs being substantially parallel to each other and having an extent parallel to one of the two sides of the pallet. The invention further concerns a system of multiple-use pallets.

10 Background Art

In Europe, the most well-known multiple-use pallets are the wooden pallets known as EUR-pallets. Such pallets are sold and re-used in a recycling system in which used pallets can be returned to a recycling station in exchange for a predetermined sum of money. The full-size version of these pallets measure 1200 x 800 x 150 mm. The system is based on far-reaching standardisation and on the idea that those involved, at all levels, agree with the structure of the recycling system. The system also features half pallets, such that two half pallets can be arranged on a full pallet to facilitate stowing of the goods. The half pallets thus measure 800 x 600 x 150 mm.

20 Wooden pallets of this kind are heavy, especially when wet. Therefore, systems of plastic pallets have been developed, inter alia, in order to facilitate the handling of the pallets. The plastic material is selected so that the pallets will stand up to the sometimes hard wear associated with the handling of the pallets in the recycling system. A pallet of this kind has a number of advantages, namely that it can be manufactured according to more specific and adapted shapes, the material usage can be reduced and the total weight is lower. A lower weight means not only that handling is made easier for the user, but also that the weight of the empty pallets that are shipped back to the recycling station is reduced, whereby also the environmental impact is reduced since less energy is consumed during transport.

Summary of the Invention

The object of the present invention is to at least partly further improve the system described above. This object is achieved by the invention through a system of multiple-use pallets, which comprises at least two multiple-use
5 pallets, each pallet comprising a load surface with two mutually perpendicular sides which each have a certain length. The length of one side of the first pallet is a first integer multiple of the length of one side of the second pallet, and the length of the other side of the first pallet is a second integer multiple of the length of the other side of the second pallet, wherein any one of said
10 first or said second integer multiple is different from one (1), and the pallets can be stacked in one another. In this way a system of multiple-use pallets with stable load surfaces is obtained, which pallets, having sides of different length, can be stacked in one another. In other words, the first and second pallets are provided with corresponding supporting legs and load surface, so
15 that the second pallet can be stacked in the first pallet, which means that the system of multiple-use pallets is a compatible system in which pallets of different size and with different load surfaces can be stacked in one another. This is also of interest from the point of view of the environment, since it enables a single shipment to include a larger number of pallets, whereby
20 fewer transport vehicles are required and the need for storage space is significantly reduced. Moreover, this effect is even further enhanced by the fact that the size of the different pallets is adapted in such a manner that the pallets are compatible in terms of size with each other, which further improves the stackability and stowability.

25 The compatible system of pallets can also be such that any one of the lengths is essentially an integer multiple of the corresponding length, as described above. For example, the length of one side of the first pallet can be between 80-120% of a first integer multiple of the length of one side of the second pallet, preferably between 95-105%, more preferably between 98-
30 102%. Also the other sides of the pallets can be provided according to the ranges exemplified above.

According to one embodiment, each pallet comprises at least two supporting legs for supporting the load surface, which supporting legs each

have a supporting surface facing away from the load surface, the supporting legs being substantially parallel to each other and having an extent parallel to one of the two sides of the pallet, wherein at least one of the supporting surfaces extends up to the load surface and forms parts thereof.

- 5 Advantageously, a system of stackable and compatible pallets with a substantially intact load surface is thus provided, which pallets also have stable supporting legs, so as to allow improved handling of the pallets in pallet racks, on roller conveyors and in computerized warehouses.

In the following the system of multiple-use pallets will also be described
10 based on an individual multiple-use pallet and different embodiments of a multiple-use pallet. The exemplifying embodiments of a single pallet according to the invention are applicable in a similar manner to at least two, or more, multiple-use pallets, which pallets can also be included in the system of multiple-use pallets, being thus compatible with each other. Accordingly,
15 the embodiments of a pallet described below can be included in a system of compatible pallets with load surface areas of varying size.

According to one embodiment, a multiple-use pallet is thus provided comprising a load surface with two mutually perpendicular sides and at least two supporting legs for supporting the load surface which supporting legs
20 each have a supporting surface facing away from the load surface, the supporting legs being substantially parallel to each other and having an extent parallel to one of the two sides of the pallet. At least one of the supporting surfaces extends up to the load surface and forms part thereof. In this way, a pallet is provided which has stable supporting legs, which at the same time
25 help to ensure that the load surface is not perforated by too many large cavities. In other words, by virtue of the fact that the supporting legs have a "meandering shape" and run from the supporting surface up to the load surface they are able to carry part of the load. With a perforated load surface the goods might otherwise, due to cavities in the load surface, be insufficiently
30 supported and unstable or might even drop through the cavities in the pallet. The solution according to the invention thus eliminates the need for an additional liner between the load and the load surface, which would otherwise require extra material and additional handling. For example, the cavities in the

load surface can be arranged such that the effective load surface adapted to support the goods arranged on the load surface constitutes more than 70% of the total area of the pallet, including the cavities. In other words, the cavities constitute less than 30% of the area of the pallet. Preferably, the effective
5 load surface can constitute more than 80%, preferably more than 90%, and most preferably more than 95%, of the total area of the load surface, including the cavities.

According to one embodiment, each supporting surface extends substantially along the whole of said side. This layout of the load surface
10 ensures that the pallet is supported in a stable manner on a surface and that it is particularly well adapted for placing in pallet racks or on roller conveyors.

According to one embodiment, each supporting leg, in a region between the supporting surface and the load surface, is formed with at least one opening, which extends parallel to said side. The opening enables
15 appropriate handling of the pallet by means of lifting devices, such as the forks of a forklift truck, which can be inserted under the load surface of the pallet for lifting and transport of one pallet or a plurality of pallets stacked in one another.

According to one embodiment, the load surface is at least partly
20 provided with a friction-enhancing material. This prevents the goods arranged on the pallet from sliding off too easily and it prevents the pallet from sliding off of a pallet rack, a roller conveyor or the forks of a forklift truck. According to one embodiment, it is only the load surface that is provided with a friction-enhancing material.

According to one embodiment, each supporting leg is conically
25 widening from the supporting surface towards the load surface. This enables the supporting legs to guide the forks of, for example, a forklift truck into the correct position under the pallet. It also contributes to the stackability, and an appropriately selected conicity may result in a space being formed between
30 the load surfaces of two pallets stacked one on top of the other, so that forks can be inserted between two stowed pallets for the purpose of lifting only one of them. Manual removal would otherwise be required.

According to one embodiment, each supporting leg forms an inner cavity which is defined by the load surface formed by the supporting surface and the walls extending from the supporting surface to said load surface, the cavity being open vertically downwards.

5 According to one embodiment, each supporting surface extends along its periphery at least partly up towards said load surface, each supporting leg forming an outer cavity which is defined by the supporting surface and the walls extending from the periphery of the supporting surface towards the load surface.

10 According to one embodiment, the outer cavity is open vertically upwards through the load surface. As a result, the pallet can receive a second pallet stacked thereon, wherein the supporting legs of the latter are able to sink at least partly into said outer cavity so that the pallets are stowed together, thereby taking up less space. This is of interest, for example, from
15 the point of view of the environment, since it enables a single shipment to include a larger number of pallets, whereby fewer transport vehicles are required and the need for storage space is significantly reduced.

 According to one embodiment, said outer and inner cavities are divided into a plurality of outer cavities and inner cavities, respectively.

20 According to one embodiment, said outer cavity is adapted to receive the supporting legs of a second pallet.

 According to one embodiment, said pallet has three supporting legs, said supporting legs being symmetrically positioned in the pallet.

25 According to one embodiment, the pallet is manufactured by injection moulding of a plastic material.

 According to one embodiment, said pallet is symmetrical about an axis that is parallel to one of the two sides of the pallet. The axis can be located at, or run through, the centre of the pallet. The pallet can further be symmetrically disposed along a geometric symmetry plane which extends parallel to one of
30 the two sides of the pallet, at the centre of the pallet, and at right angles to the load surface of the pallet.

According to one embodiment, each supporting surface of the associated supporting leg has two parallel sections, which extend along substantially the whole of said side.

5 According to one embodiment, the load surface has, adjacent the respective supporting leg, two parallel and longitudinal, or elongated, outer openings, or cavities, which extend in the direction of, or parallel to, the respective supporting leg along substantially the whole of the respective supporting leg.

10 According to a further embodiment, the two parallel sections of the supporting surfaces are adapted to be received in the parallel and longitudinal outer openings, or cavities, in the load surface when stacking two pallets. In this way, improved stackability of the pallets is obtained while preserving the load surface substantially intact. In other words, the pallet is provided with runners, which each have two parallel, elongated supporting surfaces, which
15 extend substantially along the whole runner, the load surface of the pallet being formed with corresponding parallel, elongated outer openings, or cavities, which are adapted to receive the elongated supporting surfaces when stacking one pallet on another pallet.

20 According to one embodiment, the pallet comprises intermediate longitudinal, or elongated, load surfaces disposed between the parallel, longitudinal outer openings. The intermediate elongated load surfaces extend in the direction of and along substantially the whole of the respective supporting legs so as to increase the effective load surface of the pallet.

25 According to one embodiment, the outer cavity of the respective supporting leg of the pallet comprises projecting portions, or abutments, or stop means, disposed at a suitable height inside the cavity and adapted to form a support for a second pallet stacked in the pallet. The stop means thus enable the formation of a distance between the load surface of a first lower pallet and the lower edge of the load surface of an upper, second pallet that
30 has been stacked in the first pallet. More specifically, the supporting surfaces of the supporting legs of the upper pallet thus rest on stop means of the respective supporting legs of the lower pallet. The distance can be adapted in a suitable manner, so that lifting devices, such as the forks of a forklift truck,

can be inserted between two stacked pallets for lifting of the desired pallet or the desired number of pallets from a stack of pallets. The distance is, for example, 37 mm, preferably between 10 mm and 100 mm, more preferably between 20 mm and 80 mm, and most preferably between 30 mm and
5 50 mm. Stop means can also be provided in the inner cavity of the respective supporting leg.

According to a further embodiment of the invention, there is provided a system of multiple-use pallets. The system comprises at least two multiple-use pallets. Each pallet has two mutually perpendicular sides, which each
10 have a certain length, the length of one side of the first pallet being a first integer multiple of the length of one side of the second pallet, and the length of the other side of the first pallet being a second integer multiple of the length of the other side of the second pallet. Any one of said first or second integer multiple is different from one (1). The pallets can be stacked in one another.
15 This is of interest, for example, from the point of view of the environment, since it enables a single shipment to include a larger number of pallets, whereby fewer transport vehicles are required and the need for storage space is significantly reduced. Moreover, this effect is even further enhanced by the fact that the size of the different pallets is adapted in such a manner that the
20 pallets are compatible in terms of size with each other, which further improves the stackability and stowability.

The system of pallets can also include at least two pallets, which are arranged according to any one of the embodiments described above.

According to a second aspect of the invention, it consists in a system
25 of multiple-use pallets. The system comprises at least two multiple-use pallets according to any one of the embodiments described above. Each pallet has a certain size, and the size of one pallet is an integer multiple of the size of the other pallet, said integer multiple being different from one (1).

According to a third aspect of the invention, there is provided a
30 multiple-use pallet, comprising a load surface with two mutually perpendicular sides and at least two supporting legs for supporting the load surface, which supporting legs each have a supporting surface facing away from the load surface. The supporting legs are substantially parallel to each other and have

an extent parallel to one of the two sides of the pallet, wherein at least one of the supporting surfaces extends up to the load surface and forms part thereof.

Brief Description of the Drawings

5 The present invention will be described in more detail below by way of non-limiting embodiments and with reference to the accompanying drawings, on which

Fig. 1a is a perspective view from above of a full-size multiple-use pallet according to the present invention;

10 Fig. 1b is a perspective view from above of a full-size multiple-use pallet according to the present invention;

Fig. 2a is a schematic view in longitudinal cross-section taken along the centre of the pallet in Fig. 1;

15 Fig. 2b is a schematic view in longitudinal cross-section, slightly offset from the centre, of the pallet in Fig. 1;

Fig. 2c is a schematic view in transverse cross-section taken along the centre of the pallet in Fig. 1;

Fig. 2d is a schematic view in transverse cross-section, slightly offset from the centre, of the pallet in Fig. 1;

20 Fig. 3 is a perspective view from above of a half-size multiple-use pallet according to the present invention;

Fig. 4 is a perspective view from above of a quarter-size multiple-use pallet according to the present invention;

Fig. 5 is a perspective view from below of the pallet in Fig. 1;

25 Fig. 6 is a perspective view from below of the pallet in Fig. 3;

Fig. 7 is a perspective view from below of the pallet in Fig. 4;

Fig. 8 is a perspective view from above of multiple-use pallets of different sizes according to the present invention stacked on top of and in one another;

30 Fig. 9 is a see-through perspective view from above of pallets according to Fig. 8;

Fig. 10a is a side view of two multiple-use pallets according to the present invention stacked on top of and in one another;

Fig. 10b is a side view of two multiple-use pallets according to the present invention stacked on top of and in one another;

Fig. 11 is a perspective view from above of an alternative embodiment of a full-size multiple-use pallet according to the present invention;

5 Fig. 12 is a perspective view from above of an alternative embodiment of a half-size multiple-use pallet according to the present invention;

Fig. 13 is a perspective view from above of an alternative embodiment of a full-size multiple-use pallet according to the present invention;

10 Fig. 14 is a perspective view from above of an alternative embodiment of a half-size multiple-use pallet according to the present invention;

Fig. 15a is a perspective view from above of an alternative embodiment of a quarter-size multiple-use pallet according to the present invention;

15 Fig. 15b is a perspective view from above of an alternative embodiment of a quarter-size multiple-use pallet according to the present invention;

Fig. 16 is a perspective view from above of multiple-use pallets of different sizes according to Figs 13, 14 and 15 stacked on top of and in one another, and of an alternative embodiment of a quarter-size multiple-use pallet according to the present invention;

20 Fig. 17 is a cross-sectional view showing parts of an embodiment of two pallets according to the present invention stacked on top of and in one another;

25 Fig. 18 is a cross-sectional view showing parts of an embodiment of two pallets according to the present invention stacked on top of and in one another.

Detailed Description of the Drawings

30 Fig. 1a and Fig. 1b show a multiple-use pallet 1 which has the overall dimensions 1200 x 800 x 150 mm and which is manufactured from a plastic material and provided with an anti-skid surface. The pallet can be a single-component pallet. Furthermore, the pallet 1 can be used in the EUR pallet system, since its size is compatible with said system. The pallet 1 is a full

pallet, i.e. it is of standard or full size. The pallet 1 is manufactured by injection moulding.

The pallet 1 has an upper load surface 2, as seen in the vertical direction, and three supporting legs 3, 4, two outer supporting legs 3 being
5 positioned along the long sides 5 of the pallet 1 and a middle supporting leg 4 being positioned along an imaginary centre or symmetry line between the two long sides 5 of the pallet 1. The supporting legs are in the form of supporting surfaces 7 oriented vertically downwards, by means of which the pallet 1 is supported on a surface (not shown).

10 The supporting legs 3, 4 run in a continuous manner along the whole length of the two long sides 5 of the pallet 1, i.e. the supporting surfaces 7 are in contact with the base surface along the whole length of the long sides 5. However, the supporting legs 3, 4 are perforated by two symmetrically positioned through openings 8 of a shape and a size such that the forks of a
15 forklift truck can be inserted through the openings 8 for lifting of the pallet 1. Also the middle supporting leg 4 is provided with two through openings 8 of this kind, even though this is not evident from Fig. 1a or Fig. 1b. The openings 8 in each of the three supporting legs 3, 4 are located at the same height and width level relative to each other and have the same size and shape. The
20 width of the openings 8 is 320 mm and the height is 90 mm. The distance between the supporting surface 7 and the lower edge of the openings 8 is 20 mm. The distance between the supporting surface 2 and the upper edge of the openings 8 is 40 mm.

Along the two short sides 6 of the pallet, which are arranged at right
25 angles to the two long sides 5, two symmetrically positioned spaces 9, which have a shape and size such that these too are able to receive the forks of a forklift truck for lifting and possibly moving of the pallet 1. Thus, the two spaces 9 are disposed on both sides of the middle supporting leg 4 and inside the respective outer supporting legs 3. The spaces 9 extend under the pallet
30 1 all the way out to the opposite short side 6.

All three supporting legs 3, 4 are conically widening from the respective supporting surface 7 up towards the load surface 2, as seen from one of the two short sides 6 of the pallet 1. At the level of the supporting surface 7 the

outer supporting legs 3 have a width of 77.5 mm and the middle supporting leg 4 has a width of 185 mm, or alternatively 150 mm. The distance, at the same level, between two adjoining supporting legs 3, 4 is 215 mm. At the level of the load surface 2 the outer supporting legs 3 have a width of 89.26
5 mm and the middle supporting leg 4 has a width of 196.53 mm. The distance, at the same level, between two adjoining supporting legs 3, 4 is 203.47 mm. If, on the other hand, the supporting leg 4 has a width, at the level of the supporting surface 7, of for example substantially 150 mm, the distance, at the same level, between two adjoining supporting legs 3, 4 can be adapted
10 accordingly.

Fig. 2a is a schematic view in longitudinal cross-section taken along the centre cross-section A of the pallet 1 as indicated in Fig. 1a. The load surface 2 extends vertically upwards and the supporting surface 7 of the middle supporting leg 4 extends vertically downwards. It is evident from this
15 figure that the supporting leg 4, in this cross-section A, is divided into smaller sections 7a and 7b, which extend from the continuous supporting surface 7 up towards the load surface 2 in a vertically meandering pattern. As a result, the load surface 2 too is divided into sections with openings 10a and 10b perforating the load surface 2. The supporting leg 4 is symmetrical and
20 comprises, in the respective parts thereof that are oriented towards the short sides 6, four (4) supporting surface sections 7a facing downwards and four (4) upwardly oriented openings 10a. The load surface 2 of the pallet 1 as shown in Fig. 1b is divided in a corresponding manner into sections, the supporting leg 4 being symmetrical and having, in the respective parts thereof
25 that are oriented towards the short sides 6, two (2) supporting surface sections facing downwards, corresponding to 7a, and two (2) upwardly oriented openings, corresponding to 10a.

About the centre, in Fig. 2a, the supporting leg 4 has in a corresponding manner one part comprising a total of four (4) supporting
30 surface sections 7b facing downwards and a total of four (4) upwardly oriented openings 10b. An opening 10a and 10b, respectively, has a corresponding supporting surface section 7a and 7b, respectively, in the corresponding position along the long side 5.

The pallet 1 according to Fig. 1a has a total of three (3) longitudinal sections with a profile corresponding to cross-section A.

Fig. 2b is a schematic view in longitudinal cross-section taken along a cross-section B in the longitudinal direction of the pallet 1, which cross-section B is parallel to the centre cross-section A, but taken at a position slightly closer to one of the long sides 5 but still within the middle supporting leg 4. The load surface 2 extends vertically upwards and the supporting surface 7 of the middle supporting leg 4 extends vertically downwards. It is evident from the figure that, in this cross-section B, the supporting leg 4 is not divided as in cross-section A but has an upwardly oriented opening 10c extending along the whole of the supporting leg 4. It is evident from Fig. 1a that the middle supporting leg 4 has two cross-sections B, which are symmetrical about the centre cross-section A.

In other words, the load surface and the middle supporting leg of the pallet 1 in Fig. 1a and Fig. 1b have two upwardly oriented longitudinal openings, which extend substantially along the whole of the supporting leg 4, for example, as shown, along sectional line B. The longitudinal openings, or outer cavities, are arranged adjacent one another and extend in parallel to each other and to the middle supporting leg 4. In the region of the respective outer supporting legs, the load surface 2 is provided in a similar manner with two upwardly oriented longitudinal openings, which extend along substantially the whole of the respective outer supporting leg 3.

The pallet 1 according to Fig. 1a has a total of six (6) longitudinal sections with a profile corresponding to cross-section B.

The load surface further comprises intermediate elongated load surfaces 14, which are located between the longitudinal openings 10c, the intermediate load surfaces 14 extending in the direction of and along substantially the whole of the middle supporting leg 4. More specifically, the load surface comprises, in the region of the middle supporting leg, two (2) intermediate elongated load surfaces 14, which each extend substantially from a respective short end of the middle supporting leg 4 to the centre of the middle supporting leg 4. Intermediate elongated load surfaces 13 are located in a corresponding manner between the respective longitudinal openings of

the outer supporting legs 3, which intermediate load surfaces 13 extend in the direction of and along the whole of the respective supporting leg 3. In a first pallet, the intermediate load surfaces 13, 14 are adapted to fit in downwardly oriented longitudinal elongated inner cavities which are formed in the
5 respective supporting leg of a second pallet stacked in the first pallet. The longitudinal elongated inner cavities extend in corresponding manner in the direction of and along the respective supporting leg substantially from a respective short side of the supporting leg to the centre of the supporting leg.

The pallet shown in Fig. 1b is designed in a similar manner to that
10 described above with reference to Fig. 1a, but has, for example, a different number of small sections, which extend from the continuous supporting surface 7 up towards the load surface 2 in a vertically meandering pattern, and a different number of divided sections corresponding to openings 10a and 10b which perforate the load surface 2 according to Fig. 2a.

15 Fig. 2c is a schematic view in transverse cross-section of the pallet 1 taken along the central sectional line C indicated in Fig. 1. The load surface 2 extends vertically upwards and the supporting surface 7 of the middle supporting legs 3, 4 extends vertically downwards. It is evident from the figure that, in this cross-section C, the middle supporting leg 4 is divided into two
20 smaller sections 7b, which are the same as those shown in Fig. 2a. Here too they extend from the continuous supporting surface 7 up towards the load surface 2 in a vertically meandering pattern. Also the supporting legs 3 are divided into a plurality of sections. In this cross-section C too, the load surface 2 is divided into sections, with openings 10a and 10b perforating the load
25 surface 2. The supporting leg 4 is symmetrical and has two (2) supporting surface sections 7b facing downwards and two (2) upwardly oriented openings 10b. In this cross-section C, also the supporting legs 3 are symmetrical and have two (2) supporting surface sections 7b facing downwards and two (2) upwardly oriented openings 10b.

30 The pallet 1 according to Fig. 1a has a total of nine (9) transverse sections with a profile corresponding to cross-section C.

Fig. 2d is a schematic view in transverse cross-section taken along a cross-section D in the transverse direction of the pallet 1, which cross-section

D is parallel to the centre section C, but located slightly closer to one of the short sides 6. The load surface 2 extends vertically upwards and the supporting surface 7 of the supporting legs 3, 4 extends vertically downwards. It is evident from the figure that, in this cross-section D, the supporting legs 3, 4 are not divided as in cross-section C, but have an upwardly oriented opening 10c extending transversely of the supporting legs 3, 4. It is evident from Fig 1 that all three supporting legs 3, 4 have, on both sides, two cross-sections D which are symmetrical about the centre cross-section C.

The pallet 1 according to Fig. 1 has a total of twelve (12) transverse sections with a profile corresponding to cross-section D.

Without providing a separate figure with specific cross-sections, it is evident from Fig. 1 that the supporting legs 3 have longitudinal cross-sections A and B that correspond to the parts of the middle supporting leg 4 as described above. The difference is that the width of the supporting legs 3 in the transverse direction is considerably smaller than the corresponding width of the middle supporting leg 4. In other words, the width of the section corresponding to cross-section A is smaller for each supporting leg than for the middle supporting leg 4. The width of the middle supporting leg 4, as measured in the transverse direction of the pallet 1 at the level of the load surface 2, is substantially twice the corresponding width of the respective supporting leg 3.

Fig. 3 shows a multiple-use pallet 1', which has the overall dimensions 800 x 600 x 150 mm and which is manufactured from a plastic material and provided with an anti-skid surface. The pallet can be a single-component pallet. Furthermore, the pallet 1 can be used in the EUR pallet system, since its size is compatible with said system. The pallet 1' is a half pallet, i.e. it has half the size of the full-size pallet 1 described above. The pallet 1 is manufactured by injection moulding. The following description focuses on the differences between a full-size pallet 1 and a half-size pallet 1'.

What distinguishes the half-size pallet 1' from the full-size pallet 1 is mainly the position of the three supporting legs 3', 4'. In the present figure, the supporting legs are parallel to the short sides 6. However, the pallet 1' has a corresponding load surface 2 and supporting surface 7, which are both

divided into sections of the upwardly oriented openings of the supporting legs 3', 4'. Thus, in this half pallet 1', a cross-section A' taken through the centre and extending along the middle supporting leg 4', in the same way as in the full pallet 1, extends transversely of the longitudinal extent of the pallet 1'.

- 5 The same applies for a cross-section B' taken parallel to cross-section A'. In the case of the half pallet 1', a cross-section C taken along the centre and transversely of the supporting legs 3', 4' corresponds completely in terms of its meandering structure and size with the corresponding cross-section C of the full pallet 1. However, a section according to cross-section C extends over
- 10 a considerably longer distance as compared with the longitudinal extension of the supporting legs 3', 4' before a cross-section D is to be found which, in turn, corresponds in terms of its meandering structure and size with cross-section D of the full pallet 1. In the half pallet 1' there is no cross-section C taken along the centre which is immediately followed by a cross-section D.
- 15 Instead, the half pallet 1' has at either end, close to the long sides 5, a section of cross-section C and two sections of cross-section D.

The pallet 1' according to Fig. 3 has a total of three (3) transverse sections with a profile corresponding to cross-section A'. The pallet 1' according to Fig. 3 has a total of six (6) transverse sections with a profile

20 corresponding to cross-section B'. The pallet 1' according to Fig. 3 has a total of three (3) longitudinal sections with a profile corresponding to cross-section C. The pallet 1' according to Fig. 3 has a total of four (4) longitudinal sections with a profile corresponding to cross-section D. In other words, the load surface of the pallet 1' is provided with two upwardly oriented longitudinal

25 elongated openings, which extend along sectional line B' and in the direction of and along substantially the whole of the middle supporting leg 4'. The longitudinal openings are arranged adjacent one another and are also parallel to each other and to the middle supporting leg 4.

In the region of the respective outer supporting legs 3', the load surface

30 2 is provided in a similar manner with two upwardly oriented longitudinal elongated openings, which extend in the direction of and along substantially the whole of the respective outer supporting leg 3'. The supporting surface

has a total of six (6) upwardly oriented longitudinal elongated openings, which extend in pairs along the respective supporting legs 3', 4'.

The load surface 2 further comprises an intermediate elongated load surface 14', which is located between the longitudinal openings, the
5 intermediate load surface 14' extending in the direction of and along substantially the whole of the middle supporting leg 4' in a longitudinal direction. Intermediate load surfaces 13' are located in a corresponding manner between the respective longitudinal openings of the outer supporting legs 3', which intermediate load surfaces 13' extend in the direction of and
10 along substantially the whole of the respective supporting leg 3 in a longitudinal direction. In a first pallet, the intermediate load surfaces 13', 14' are adapted to fit in downwardly oriented longitudinal elongated inner cavities which are formed in the respective supporting leg of a second pallet stacked in the first pallet. The longitudinal elongated inner cavities extend in a
15 corresponding manner in the direction of and along the respective supporting leg substantially from the respective short side of the supporting leg to the centre of the supporting leg.

The supporting legs 3', 4' of the half pallet 1' have the same conically widening shape from the supporting surface 7 to the load surface 2, but has
20 at least one, only one, or at least two, through opening(s) 8 formed in the supporting legs 3', 4' whose size and shape and position between the supporting legs 3', 4' are equivalent to the size, shape and position of the full pallet 1. The spaces 9 between the outer supporting legs 3' and the middle supporting leg 4' are the same as in the full pallet 1 and extend in a
25 corresponding manner from one side, in this case a long side 5, to the opposite side, the other long side 5.

As will be shown below with reference to Fig. 8, the half pallet 1' is so designed that it can be placed on top of (or under) the full pallet 1 in such a manner that the supporting legs 3', 4' of the half pallet 1' are oriented in the
30 same longitudinal direction as the supporting legs 3, 4 of the full pallet 1 and with one short side 6 of the half pallet 1' positioned along one half of a long side 5 of the full pallet 1, such that the supporting surfaces 7a and 7b are positioned above the openings 10a, 10b and 10c of the full pallet 1 and sink

into said openings. In this way the half pallet 1' is stowed in the full pallet 1 in such a manner that the height when stowed is lower than the aggregate height of the individual pallets. This results in considerable volume savings in conjunction with transport. Moreover, the position of the openings 8 of the
5 respective supporting legs 3, 4 and 3', 4' ensure that they are aligned so that the forks of a forklift truck can be inserted in the openings 8 also when the pallets 1, 1' are stowed.

Fig. 4 shows a multiple-use pallet 1', which has the overall dimensions 600 x 400 x 150 mm and which is manufactured from a plastic material and
10 provided with an anti-skid surface. The pallet can be a single-component pallet. Furthermore, the pallet 1 can be used in the EUR pallet system, since its size is compatible with said system. The pallet 1'' is a quarter pallet, i.e. it is a quarter of the size of the full-size pallet 1 described above and, thus, half the size of the half-size pallet 1' described above. The pallet 1'' is
15 manufactured by injection moulding. The following description focuses on the differences between a full-size pallet 1 and a quarter-size pallet 1''.

As in the case of the full pallet 1 the supporting legs 3' of the quarter pallet 1'' have an extent parallel to the long sides 5 of the quarter pallet 1''. However, the quarter pallet 1'' has only two outer supporting legs 3'' and no
20 middle supporting leg. However, the supporting legs 3'' of the quarter-size pallet 1'' have two transverse through openings 8 formed in the supporting legs 3'' and adapted to receive lifting forks, but only one space 9 between the supporting legs 3'', which extends along the whole length of the supporting legs 3''. The conical shape of the supporting legs is the same and the shape
25 and size of the space 9 correspond to the shape and size of the full pallets 1 and half pallets 1'. The quarter pallet 1'' too has sections of a cross-section according to A, A', B, B', C and D above. However, some cross-sections are taken at a different position as compared with the pallet 1''. Cross-sections A' and B' are the same in terms of shape and size as in the half pallet 1', but in
30 the quarter pallet 1' they are positioned along the outer supporting legs 3'' only. The transverse cross-sections C'' and D'' differ from cross-sections C and D in that they have fewer sections with supporting surface sections 7a and 7b and in the number of openings 10a and 10b.

The pallet 1' according to Fig. 4 has a total of two (2) longitudinal sections with a profile corresponding to cross-section A'. The pallet 1' according to Fig. 4 has a total of two (2) longitudinal sections with a profile corresponding to cross-section B'. The pallet 1' according to Fig. 4 has a total of three (3) transverse sections with a profile corresponding to cross-section C". The pallet 1' according to Fig. 4 has a total of four (4) transverse sections with a profile corresponding to cross-section D".

As in the case described above where the size and shape of the half pallet 1" was adapted to match the full pallet 1 for stowing purposes, the quarter pallet 1" is adapted to be positioned on top of or under any one of the two pallets. Two quarter pallets 1" can be accommodated on a half pallet 1' and four quarter pallets 1" can be accommodated on a full pallet 1. This will be described further below with reference to Fig. 8.

Figs 5, 6 and 7 are perspective views from below of the pallets 1, 1', 1" shown in Figs 1, 3 and 4. It is worth noting that in all three types of pallets 1, 1', 1" all of the supporting legs 3, 3', 3" and 4, 4' have, adjacent their supporting surfaces 7, at least one section which extends parallel to one side 5, 6 of the whole pallet. As a result, the pallets 1, 1' and 1" will always stand firmly on a surface and are well adapted for use in pallet racks or on roller conveyors, since the pallets 1, 1' and 1" will not end up not engaging with the surface or being stuck. Fig. 6 shows a particularly interesting manner of enhancing the load-bearing capacity of the load surface 2. By providing a diagonal bracing structure of the same material as the pallet 1, 1', 1", suitably during manufacture of the whole pallet 1, 1', 1", the rigidity of the load surface 2, in particular, is increased, whereby the load-bearing capacity and service life of the load surface 2 are improved. This reinforcement is suitably provided in all the sizes of the pallets 1, 1', 1".

Furthermore, the meandering extension of the cross-sections of the pallets 1, 1' and 1" offers a very simple structure, which at the same time ensures that the load surfaces 7 make contact with the surface as described above and that the openings 10a, 10b and 10c formed in the load surface 2 are not too large with respect to the size of the products that are to be placed on said load surface 2. The goods may otherwise need to be of a certain size

so as not to fall through these openings 10a, 10b and 10c, or an additional liner in the form of a board or the like must be placed on the load surface 2 before the goods can be arranged thereon. By virtue of fact that the supporting legs 3, 3', 3'' and 4, 4' form continuous, longitudinal "runners" in combination with the fact that the load surface 2 is formed substantially in one piece relative to goods placed thereon and that the pallet system comprises three pallet sizes which are fully compatible with each other so as to allow easy stowing thereof, i.e. stacking in a space saving manner, a system which is highly useful and powerful is obtained. It is conceivable to provide additional pallet sizes based on other sizes, but where the size is an integer multiple of the EUR pallet system sizes. However, the sizes shown herein are the ones that are most frequently used and that can be readily adapted to existing systems.

Figs 5 and 6 also show the two longitudinal, parallel supporting surfaces of each supporting leg, or runner, between which longitudinal, elongated inner cavities are formed.

Fig. 8 shows such a stowing of the different pallet sizes. The bottom layer is a full pallet 1. The next layer also consists of a full pallet 1. The next layer comprises, from left to right in the figure, a quarter pallet 1'' and a half pallet 1'. The same pallet types can be found in the next layer. Finally, a quarter pallet 1'' is arranged in both of the two uppermost layers. This clearly shows that two quarter pallets 1'' can be arranged side by side on a half pallet 1' and that two half pallets 1' can be arranged side by side on a full pallet 1 and, finally, that four quarter pallets 1'' can be arranged side by side on a full pallet 1.

Fig. 9 shows the same setup as in Fig. 8, but here the supporting legs 3, 3', 3'' and 4, 4' of some of the pallets 1, 1', 1'' are visible through the material of the pallet 1, 1', 1'' immediately below.

Fig. 10a is a side view of two full pallets 1 or two half pallets 1'' in stowed condition. The upper pallet 1, 1' has sunk into the lower pallet 1, 1', wherein a distance is formed, due to the conical shape of the supporting legs 3, 3', 3'' and 4, 4' in the transverse direction, between the load surface 2 of the lower pallet 1, 1' and the lower edge of the load surface of the upper pallet

1, 1'. Similarly, a corresponding distance is formed if a quarter pallet 1" is stowed in a full or half pallet 1, 1'. As a result of this distance, it is possible to insert, for example, the forks of a forklift truck between two stacked pallets 1, 1', 1" and to remove a smaller number of pallets 1, 1', 1" and not the whole stack. Corresponding distances are formed across the whole load surfaces 2, which means that the through openings 8 formed in the supporting legs 3, 3', 3" and 4, 4" can be used in a corresponding manner for the insertion of forks and for lifting of part of a pallet stack. In other words, the openings 8 and the distance between two stacked pallets interact so as to allow a desired number of pallets to be removed from an existing stack of pallets by lifting with the aid of for example a forklift truck or an automatic pallet handling system.

In the present embodiment, the space is 37 mm. Another distance can be selected, for example a distance between 10 mm and 100 mm, preferably between 20 mm and 80 mm, more preferably between 30 mm and 50 mm, but selecting the distance is a question of weighing the need to be able to introduce forks in the openings 8 and the spaces 9 between the load surfaces 2 of two pallets 1, 1', 1" stacked one on top of the other against the desire to reduce the height/volume of the stack so as to save space, for example, during return shipment. By selecting the distance according to the above, a storage space that previously could hold some 16 full-size pallets 1 is now able to receive 30 pallets 1. In the case of half-size pallets 1' the storage space can now receive 60 pallets 1' as compared with 32 pallets 1' originally. Such stowing is highly beneficial for the environment since more pallets 1, 1', 1" can be shipped back at the same time, which means that fewer transports are needed on the whole, but it is also highly beneficial in terms of savings in storage space for unused pallets 1, 1', 1".

Fig. 10b is a side view of two full pallets 1 or two half pallets 1" in stowed condition. The upper pallet 1, 1' has sunk into the lower pallet 1, 1', wherein the inner cavities of the respective supporting legs 3, 3', 3" and 4, 4' comprise projecting portions, abutments or stop means 11, which cause a distance to be formed between the load surface 2 of the lower pallet 1, 1' and the lower edge of the load surface 2 of the upper pallet 1, 1'. In other words, the supporting surfaces of the supporting legs rest on supporting surfaces 12

of the upper stop means provided on the respective supporting legs of the lower pallet. The distance can be varied according to ranges similar to those stated above with reference to Fig. 10a.

Fig. 11 shows an alternative embodiment of a full pallet 1. The
5 difference as compared with the embodiment shown in Fig. 1 is the appearance of cross-section C. In the present embodiment, the outer supporting legs 3 are asymmetrically formed such that one upwardly oriented opening 10b through the load surface 2 has been removed. In other words, the number of sections corresponding to cross-section B has been reduced
10 from six to four. The sections that have been removed are those sections corresponding to cross-section B which in Fig. 1 were located farthest out towards the long sides 5 in the supporting legs 3. In all other respects the present embodiment can be used in the same way as the full pallet of Fig. 1. However, the full pallet 1 according to Fig. 11 cannot be used in combination
15 with the half pallet 1' of Fig. 3, but the quarter pallet 1'' of Fig. 4 can be combined with the present pallet 1. On the other hand, the full pallet 1 of Fig. 11 could, where desirable, be placed on top of a full pallet 1 according to Fig. 1.

Fig. 12 shows an alternative embodiment of a half pallet 1'. The
20 difference as compared with the embodiment shown in Fig. 3 is the appearance of cross-section C. In the present embodiment, the outer supporting legs 3' are asymmetrically formed such that one upwardly oriented opening 10b through the load surface 2 has been removed. In other words, the number of sections corresponding to cross-section B' has been reduced
25 from six to four. The removed sections are those sections corresponding to cross-section B' which in Fig. 3 were located farthest out towards the short sides 5 in the supporting legs 3'. In all other respects the present embodiment can be used in the same way as the half pallet of Fig. 3. The half pallet 1' according to Fig. 12 can be used in combination with the full pallet 1 of Fig. 1
30 and the half pallet 1' of Fig. 3 provided that the present half pallet 1' is arranged on top of the others. As regards the quarter pallet 1'' of Fig. 4 the same condition applies, namely that the half pallet 1' according to the present figure must be arranged on top of the former. However, the present half pallet

1' is to be used, first and foremost, in combination with the full pallet 1 of Fig. 11 and the quarter pallet 1'' of Fig. 4, since this combination does not restrict the order in which stacking and stowing can be carried out.

5 Fig. 13 shows a further alternative embodiment of a full pallet 1. The difference as compared with the embodiment shown in Fig. 1 is the appearance of cross-sections B and C. However, cross-section C of the present embodiment is the same as in the embodiment shown in Fig. 11. In the present embodiment, both the outer supporting legs 3 and the middle supporting leg 4 have each been divided into three sections, as seen in the
10 longitudinal direction of the supporting legs 3, 4. Seen in the same longitudinal direction, they are asymmetrically formed such that one upwardly oriented opening 10b through the load surface 2 has been removed as compared with the embodiment of Fig. 1. This means that neither the outer supporting legs 3 nor the middle supporting leg 4 extend along the whole long
15 side 5 any longer and that there is no continuous supporting surface 7 along this side. Cross-section B is here divided into three shorter upwardly oriented openings 10c. As a result, the load surface 2 is less perforated. As in the embodiment in Fig. 11 the number of sections corresponding to cross-section B has been reduced from six to four as compared with the embodiment in Fig.
20 1. The sections that have been removed are those sections corresponding to cross-section B which in Fig. 1 were located farthest out towards the long sides 5 in the supporting legs 3. In all other respects the present embodiment can be used in the same way as the full pallet of Fig. 1 and Fig. 11. However, the full pallets 1 according to Fig. 11 and Fig. 1 cannot be used in
25 combination with the full pallet 1' of Fig. 13 unless the latter is stacked and stowed on top of the former. The best and most convenient approach is to use, within a system, corresponding supporting leg structures for the different sizes of the pallets 1, 1', 1'', so that no energy has to be wasted in sorting the pallets according to a specific order.

30 Fig. 14 shows a further alternative embodiment of a half pallet 1'. The difference as compared with the embodiment shown in Fig. 3 is the appearance of cross-sections B' and C. However, cross-section C of the present embodiment is the same as in the embodiment shown in Fig. 12. In

the present embodiment, both the outer supporting legs 3' and the middle supporting leg 4' have each been divided into two sections, as seen in the longitudinal direction of the supporting legs 3', 4'. Seen in the same longitudinal extension, they are asymmetrically formed such that one upwardly oriented opening 10b through the load surface 2 has been removed as compared with the embodiment of Fig. 3. This means that neither the outer supporting legs 3 nor the middle supporting leg 4 extend along the whole short side 6 any longer and that there is no continuous supporting surface 7 along this side. Cross-section B' is here divided into two shorter upwardly oriented openings 10c. As a result, the load surface 2 is less perforated. As in the embodiment in Fig. 12 the number of sections corresponding to cross-section B has been reduced from six to four as compared with the embodiment of Fig. 3. The removed sections are those sections corresponding to cross-section B' which in Fig. 3 were located farthest out towards the short sides 6 in the supporting legs 3'. In all other respects the present embodiment can be used in the same way as the half pallet of Fig. 3 and Fig. 12. However, the full pallet 1 according to Fig. 1 and Fig. 11 cannot be used in combination with the half pallet 1' of Fig. 14, but the quarter pallet 1'' of Fig. 4 can be combined with the present pallet 1'.

Fig. 15a shows an alternative embodiment of a quarter pallet 1''. The difference as compared with the embodiment shown in Fig. 4 is the appearance of cross-section B'. In the present embodiment, the outer supporting legs 3'' have each been divided into two sections, as seen in the longitudinal direction of the supporting legs 3''. Seen in the same longitudinal extension, they are asymmetrically formed such that one upwardly oriented opening 10b through the load surface 2 has been removed as compared with the embodiment of Fig. 4. This means that the outer supporting legs 3'' no longer extend along the whole long side 5 and that there is no continuous supporting surface 7 along this side. Cross-section B' is here divided into two shorter upwardly oriented openings 10c. As a result, the load surface 2 is less perforated. In all other respects the present embodiment can be used in the same way as the quarter pallet 1'' of Fig. 4. However, neither the full pallet 1

according to Fig. 1 and Fig. 11 nor the half pallets 1' of Fig. 12 and Fig. 14 can be combined with the present quarter pallet 1''.

Fig. 15b shows a further alternative embodiment of a quarter pallet 1''. Cross-section B' is here divided into four shorter upwardly oriented openings 5 10c. In each corner, the supporting legs have two supporting surfaces 7 and an intermediate stop means 15, which stop means has a downwardly oriented supporting surface 16. By virtue of the stop means 15 it is possible to achieve the appropriate distance between two stacked pallets.

Fig. 16 shows basically the same figure as Fig. 8, the difference being 10 that the stowed pallets 1, 1', 1'' are of the type shown in Fig. 13, Fig. 14, and Fig. 4.

Fig. 17 is a transverse cross-sectional view showing parts of an embodiment of two (2) half pallets 1'. An upper half pallet is stacked in a lower half pallet. Alternatively, the pallets are two (2) full pallets 1, or a half 15 pallet 1' and a full pallet 1, the half pallet being stacked in the full pallet or vice versa. Transverse supporting means 11 are arranged in the openings in the load surface of the lower pallet. The supporting means 11 extend over the whole length of the opening in a transverse direction, which coincides for example with cross-section C in Fig. 3, and restricts the opening in a 20 downward direction. The supporting means 11 of the lower pallet each have an upwardly oriented supporting surface 12, the supporting surfaces of the supporting legs of the upper pallet resting on the supporting surfaces 12 of the lower pallet.

Fig. 18 is a transverse cross-sectional view showing parts of two (2) 25 stacked quarter pallets 1'' according to Fig. 15b. The upper quarter pallet 1'' is stacked in the lower quarter pallet 1'', the supporting leg portions of the upper pallet being disposed or fitted, by way of two lower supporting surfaces, in openings in the load surface 2 of the lower pallet. The downwardly oriented supporting surface 16 of the supporting means 15 of the upper pallet abuts 30 against a portion of the load surface 2 of the lower pallet that is located between the openings in the load surface of the lower pallet. In other words, the supporting leg 3'' has two downwardly projecting portions which each

have a lower supporting surface 7, the supporting means 15 being disposed between the projecting portions.

The present invention has been described above mainly with respect to individual pallets 1, 1', 1'' and their design. It is important to realise, however, that the scope of the basic concept of the invention is even wider. The invention may also be described as a system of multiple-use pallets, wherein the system comprises two or more multiple-use pallets 1, 1', 1''. Generally, the pallets 1, 1', 1'' of the system each have two mutually perpendicular sides 5, 6, which each have a certain length. The length of one side of the first pallet is a first integer multiple of the length of one side of the second pallet, and the length of the other side of the first pallet is a second integer multiple of the length of the other side of the second pallet. It is thus possible to stack or stow the pallets 1, 1', 1'' in one another, i.e. they are compatible with each other. The pallets 1, 1', 1'' according to the inventive system can be of the type described above for each individual case.

According to an illustrative example, the proportion between the size of the full pallet 1 and the size of the half pallet 1', in a system of pallets 1, 1', 1'' according to Fig. 1, Fig. 3 and Fig. 4, would be a first integer multiple of one (1) and a second integer multiple of two (2). The same first and second integer multiples are obtained when comparing the half pallet 1' and the quarter pallet 1'' in the same way. The comparison between the full pallet 1 and the quarter pallet 1'' gives a first integer multiple of two (2) and a second integer multiple of two (2).

Various embodiments of the present invention are conceivable. For example, the invention has up to now been described with respect to rectangular pallets 1, 1', 1''. However, it is equally possible to imagine an entire system of square pallets or individual square pallets which are included in the system. Other shapes of the supporting legs 3, 3', 3'' are also conceivable. To enable stowing when stacking pallets 1, 1', 1'' of different sizes it is convenient for the upwardly oriented openings 10a, 10b, 10c through the load surface 2 to have a shape that corresponds to the supporting surface sectioning of the supporting legs 3, 3', 3'' and 4, 4'. Moreover, a

pallet, for example a full pallet 1, which is to receive two half pallets 1' may conveniently be provided with openings through the load surface 2 according to a structure that represents a "doubling" of the supporting surface sectioning of the half pallets 1", i.e. the supporting surface sectioning of a half pallet 1' is arranged adjacent the same supporting surface sectioning of the load surface 2 of the full pallet 1.

In a further embodiment which can be implemented in all the above embodiments, drainage openings are provided in the supporting legs 3, 3', 3'' and 4, 4', and especially in their supporting surfaces 7, for draining of the supporting legs 3, 3', 3''. With reference to Figs 1a and 1b, it is evident that, in the embodiment featuring openings 8 in the side of the supporting legs 3, 3', 3'' and 4, 4', a substantially vertically oriented edge is formed along said side. During washing or transport, this edge, together with the opening 8 itself and the upwardly oriented openings 10a, 10b, 10c through the load surface 2, can receive water. The water may then accumulate in the supporting legs 3, 3', 3'' and 4, 4' between the vertical edges. This is undesirable, for example for sanitary reasons, and so a number of small, or a few large, drainage openings can be provided in the load surface 2.

Furthermore, it may be suitable to ensure that the edges are bevelled and that the edges of the openings 8 are rounded, since this helps to prevent lifting forks that accidentally hit an edge from being blocked or damaging the material of the pallet 1, 1', 1''. If the edges are bevelled and/or rounded they will guide the lifting forks into the correct position, thereby reducing the stress on the material and, thus, improving the service life of the pallet 1, 1', 1''.

In order to reduce the risk that a vacuum should occur during separation of two stacked pallets 1, 1', 1'', it is convenient to provide vertically extending reinforcement ribs of preferably two or more different heights immediately adjacent to the underside of the load surface 2 in the region of the supporting legs 3, 3', 3'' and 4, 4', which reinforcement ribs, in addition to their reinforcing function, also ensure – and this is perhaps their most important function - that there is enough space so that air can circulate into the inner cavities defined between the load surface 2 formed by the supporting surface 7 and the walls formed where the supporting surface 7

extends upwards towards the load surface 2. Because a gap is formed between the material of the two pallets 1, 1', 1" stacked one of top of the other, air can be sucked in without creating a resistance strong enough to counteract the separating movement. An example of such a position is above the opening 7b in Fig. 2c; another is under the opening 10b on top of the supporting surface 7 in the same figure. In the latter example, four vertical ribs are conveniently provided which extend from the supporting surface 7 upwards, one rib in each of the four sides around the centre, i.e. spaced apart by 90 degrees.

CLAIMS

1. A system of multiple-use pallets (1, 1', 1''), characterised in that the system comprises at least two multiple-use pallets (1, 1', 1''), each pallet
5 (1, 1', 1'') comprising a load surface (2) with two mutually perpendicular sides (5, 6) which each have a certain length, the length of one side (5, 6) of the first pallet being a first integer multiple of the length of one side (5, 6) of the second pallet (1, 1', 1''), and the length of the other side (5, 6) of the first pallet (1, 1', 1'') being a second integer multiple of the length of the other side
10 (5, 6) of the second pallet (1, 1', 1''), wherein any one of said first or second integer multiple is different from one (1), and that the pallets (1, 1', 1'') are stackable in one another.

2. The system of pallets according to claim 1, wherein at least a first one of said pallets (1, 1', 1'') comprises at least two supporting legs (3, 3',
15 3'', 4, 4') for supporting the load surface (2), which supporting legs each have a supporting surface (7) facing away from the load surface (2), the supporting legs (3, 3', 3'', 4, 4') being substantially parallel to each other and having an extent parallel to one of the two sides (5, 6) of the pallet (1, 1', 1''), wherein at least one of the supporting surfaces (7) extends up to the load surface (2) and
20 forms parts thereof.

3. The system of pallets according to claim 2, wherein the supporting surfaces (7) of said first pallet extend along substantially the whole of said side (5, 6).

4. The system of pallets according to any one of claims 2-3,
25 wherein each supporting leg (3, 3', 3'', 4, 4') of said first pallet, in a region between the supporting surface (7) and the load surface (2), is formed with at least one opening (8), which extends parallel to said side (5, 6).

5. The system of pallets according to any one of claims 2-4,
wherein the load surface (2) of said first pallet is at least partly provided with a
30 friction-enhancing material.

6. The system of pallets according to any one of claims 2-5,
wherein each supporting leg (3, 3', 3'', 4, 4') of said first pallet is conically widening from the supporting surface (7) towards the load surface (2).

7. The system of pallets according to any one of claims 2-6, wherein each supporting leg (3, 3', 3'', 4, 4') of said first pallet forms an inner cavity which is defined by the load surface (2) formed by the supporting surface (7) and the walls extending from the supporting surface (7) to said load surface (2), the cavity being open vertically downwards.

8. The system of pallets according to any one of claims 2-7, wherein each supporting surface (7) of said first pallet extends along its periphery at least partly up towards said load surface (2), each supporting leg (3, 3', 3'', 4, 4'') forming an outer cavity (7) which is defined by the supporting surface (7) and the walls extending from the periphery of the supporting surface (7) towards the load surface (2).

9. The system of pallets according to claim 8, wherein the outer cavity is open (10a, 10b, 10c) vertically upwards through the load surface (2).

10. The system of pallets according to claim 6, taken together with claim 8 or claim 9, wherein the outer and inner cavities of said first pallet are divided into a plurality of outer cavities and inner cavities, respectively.

11. The system of pallets according to any one of claims 8-10, wherein said outer cavity of said first pallet is adapted to receive the supporting legs (3, 3', 3'', 4, 4') of the second pallet (1, 1', 1'').

12. The system of pallets according to any one of claims 2-11, wherein said first pallet (1, 1', 1'') has three supporting legs (3, 3', 3'', 4, 4'), said supporting legs being symmetrically positioned in the pallet (1, 1', 1'').

13. The system of pallets according to any one of the preceding claims, wherein at least one of said pallets is manufactured by injection moulding of a plastic material.

14. The system of pallets (1, 1', 1'') according to any one of the preceding claims, wherein at least one of said pallets (1, 1', 1'') is symmetrical about an axis that is parallel to one (5, 6) of the two sides (5, 6) of the pallet (1, 1', 1'') and runs through the centre of the pallet.

15. The system of pallets according to any one of claims 2-14, wherein the supporting surfaces (7) of said first pallet for the respective supporting legs (3, 3', 3'', 4, 4') have two parallel sections, which extend along substantially the whole of said side (5, 6).

16. The system of pallets according to any one of claims 2-15, wherein at least two pallets are arranged according to said first pallet or said pallet.
17. The system of multiple-use pallets according to any one of
5 claims 1-16, wherein each pallet (1, 1', 1'') has a certain size and wherein the size of one pallet is an integer multiple of the size of the other pallet (1, 1', 1''), said integer multiple being different from one (1).
18. A multiple-use pallet (1, 1', 1''), comprising a load surface (2)
10 with two mutually perpendicular sides (5, 6) and at least two supporting legs (3, 3', 3'', 4, 4') for supporting the load surface (2), which supporting legs each have a supporting surface (7) facing away from the load surface (2), the supporting legs (3, 3', 3'', 4, 4') being substantially parallel to each other and having an extent parallel to one of the two sides (5, 6) of the pallet (1, 1', 1''), characterised in that at least one of the supporting surfaces (7) extends up to
15 the load surface (2) and forms parts thereof.

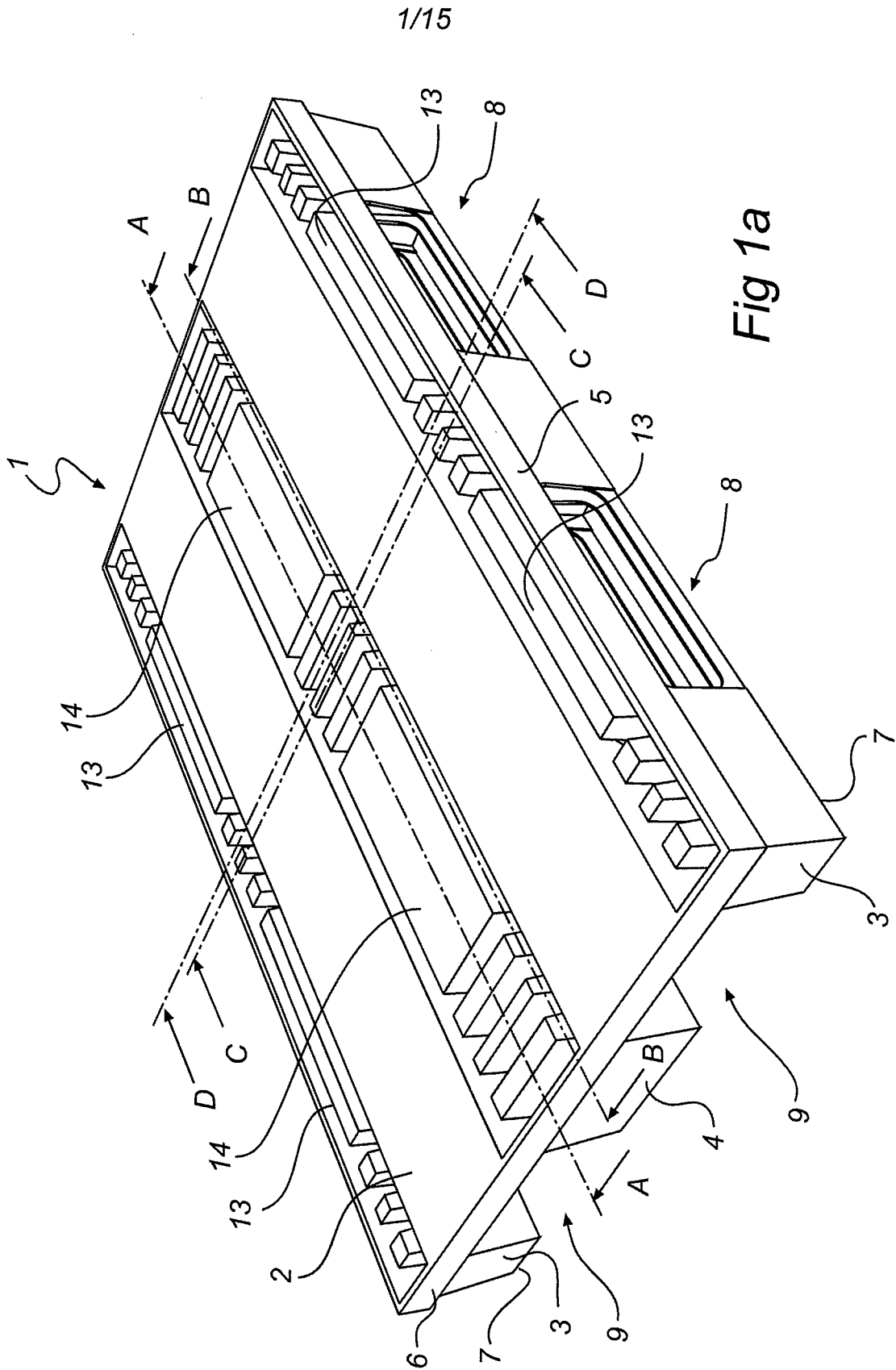
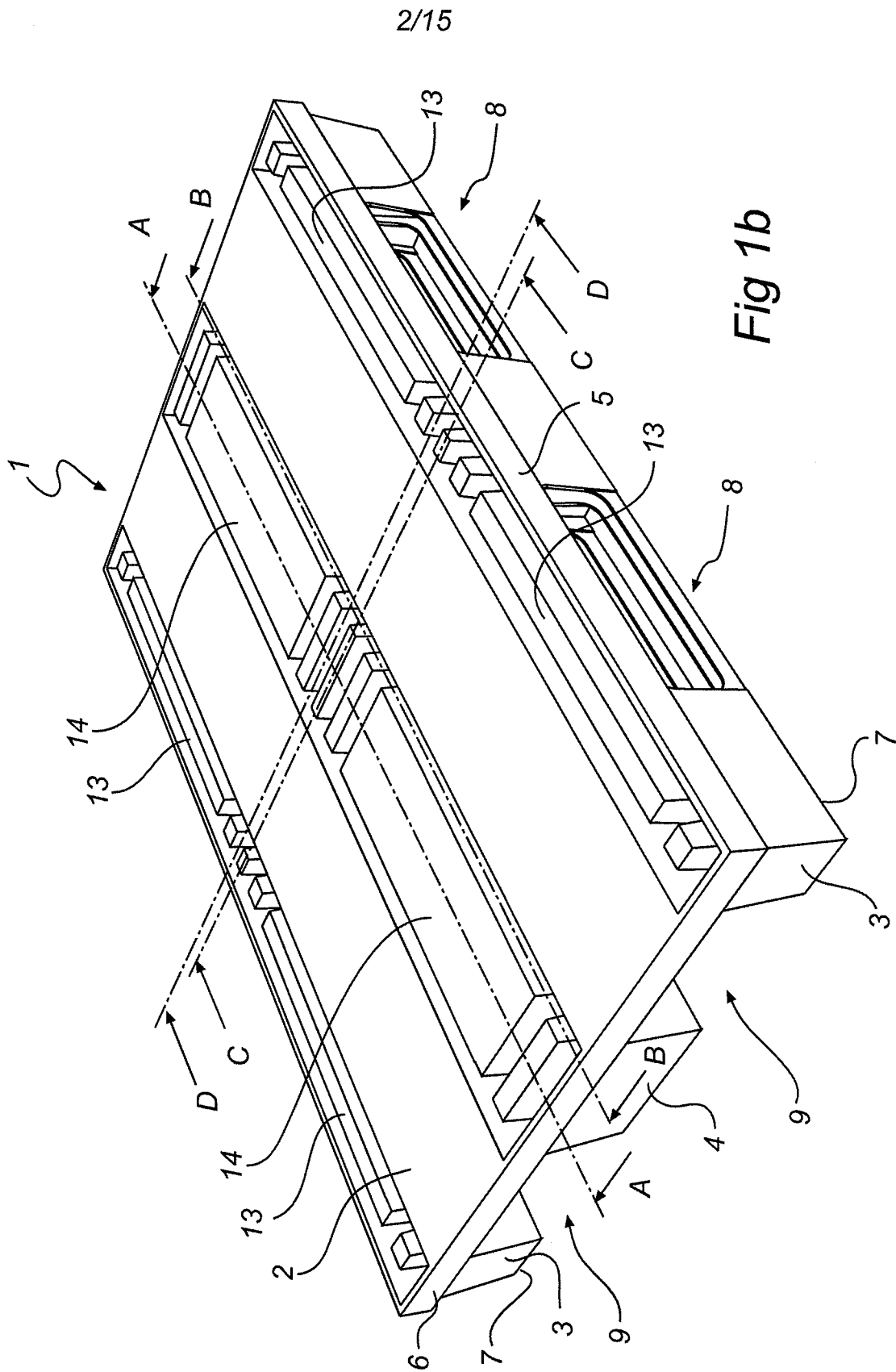

Fig 1a



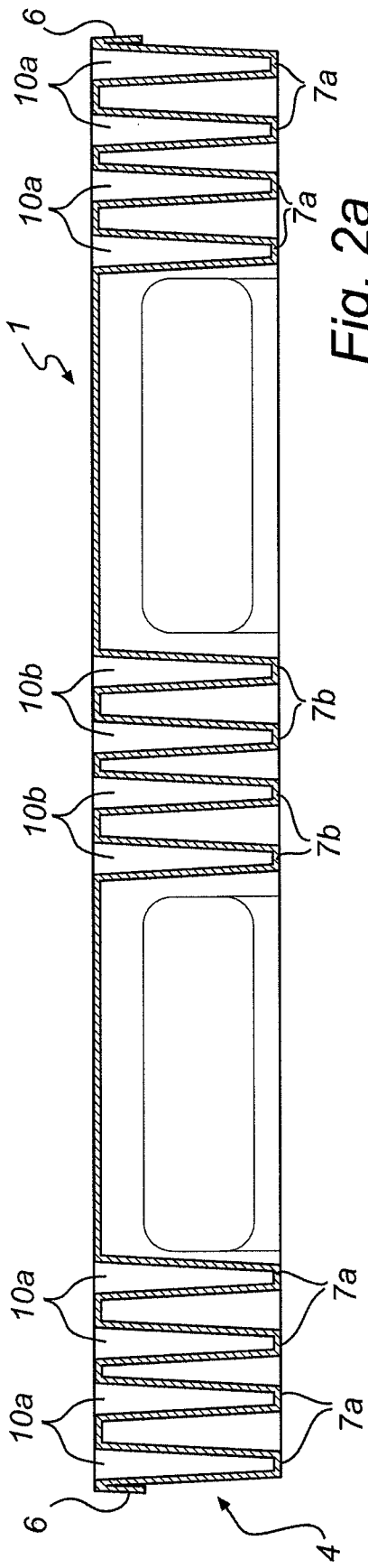

Fig. 2a

3/15

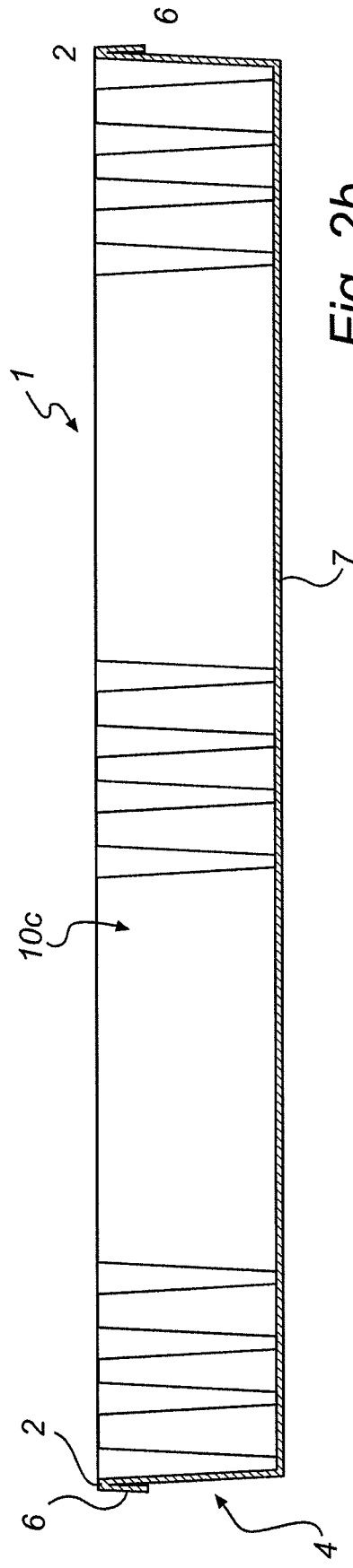
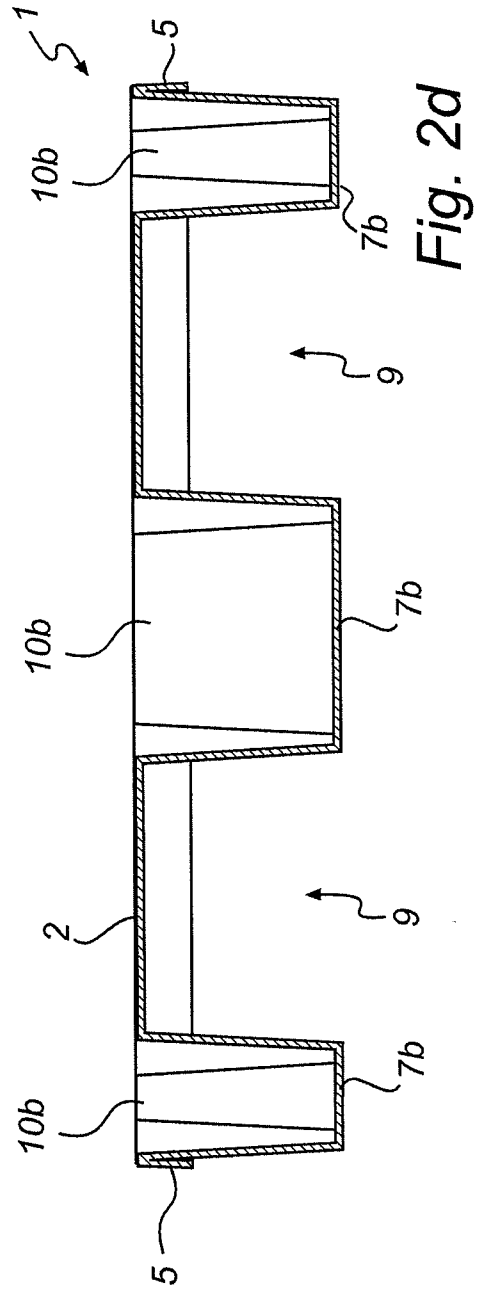
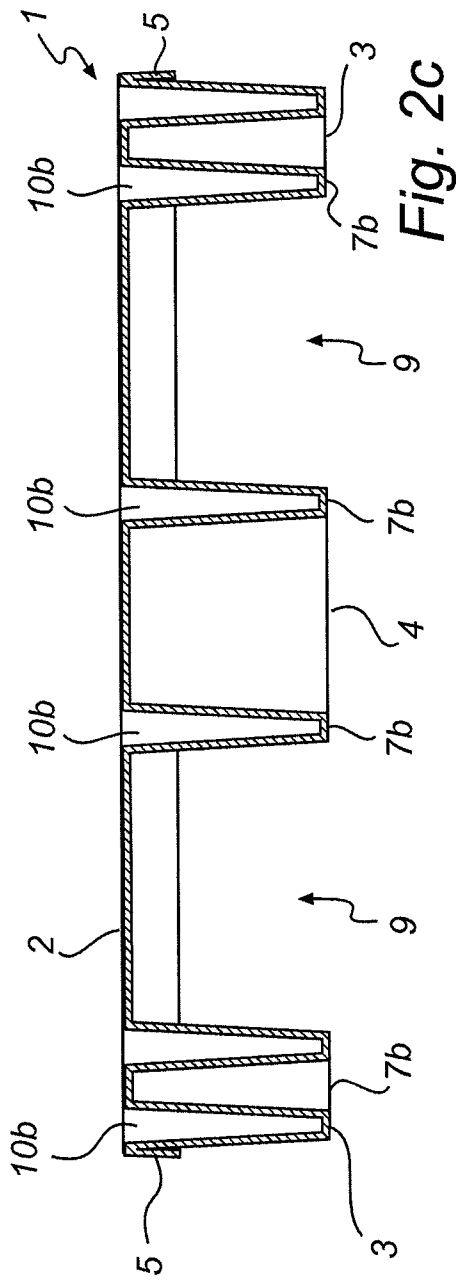

Fig. 2b



5/15

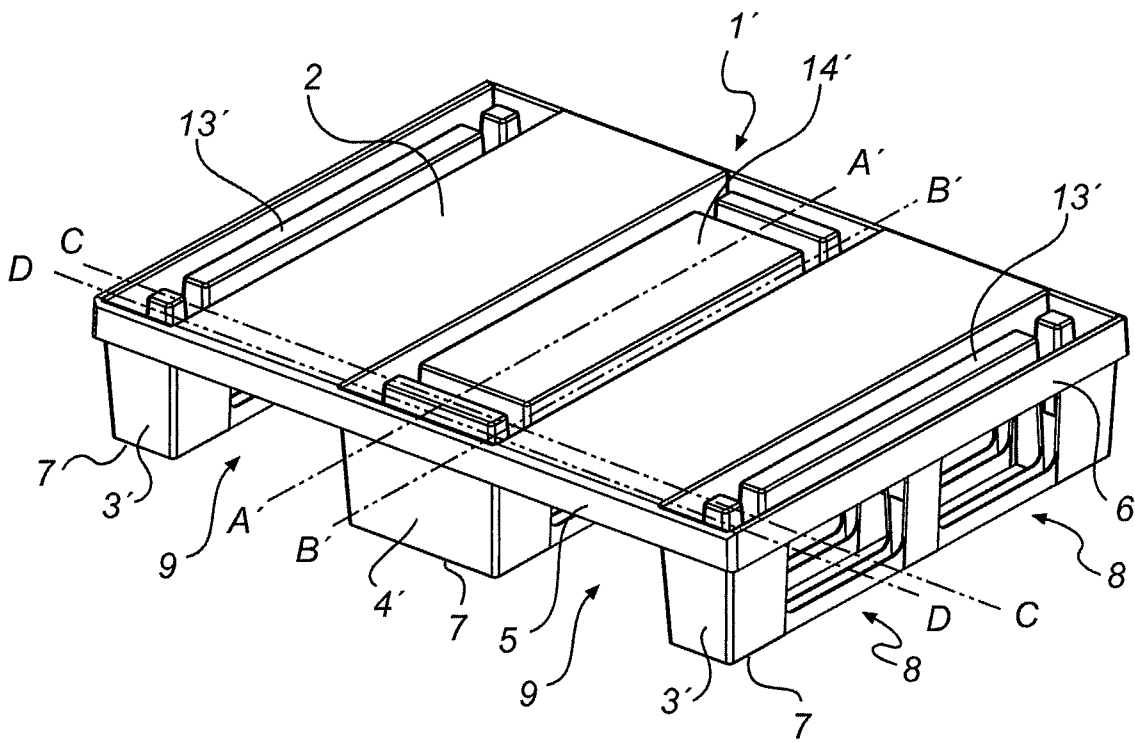

Fig. 3

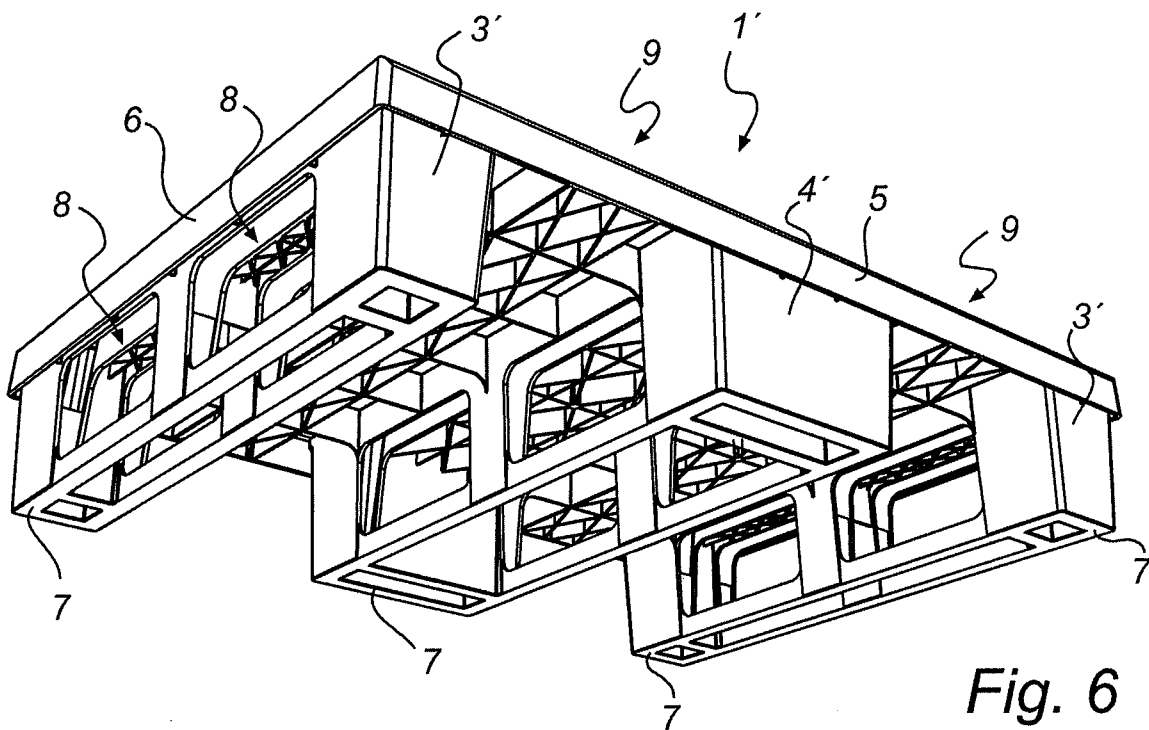

Fig. 6

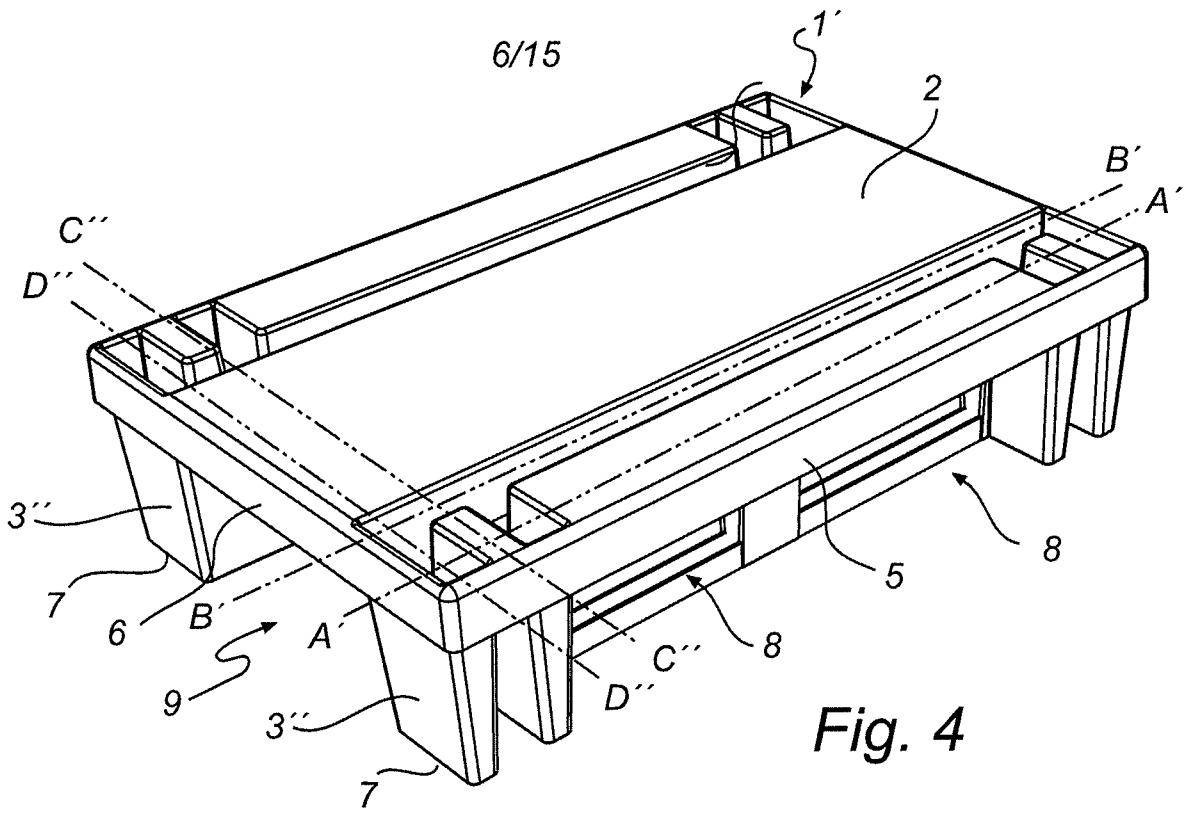

Fig. 4

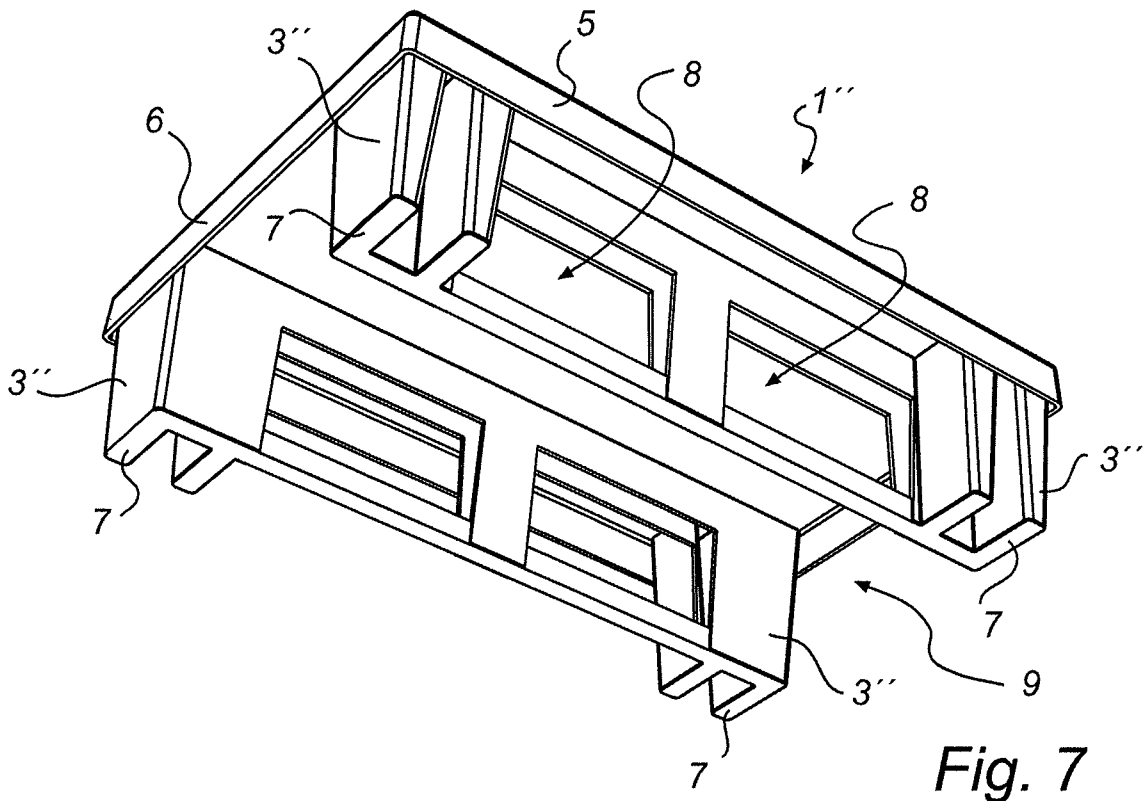

Fig. 7

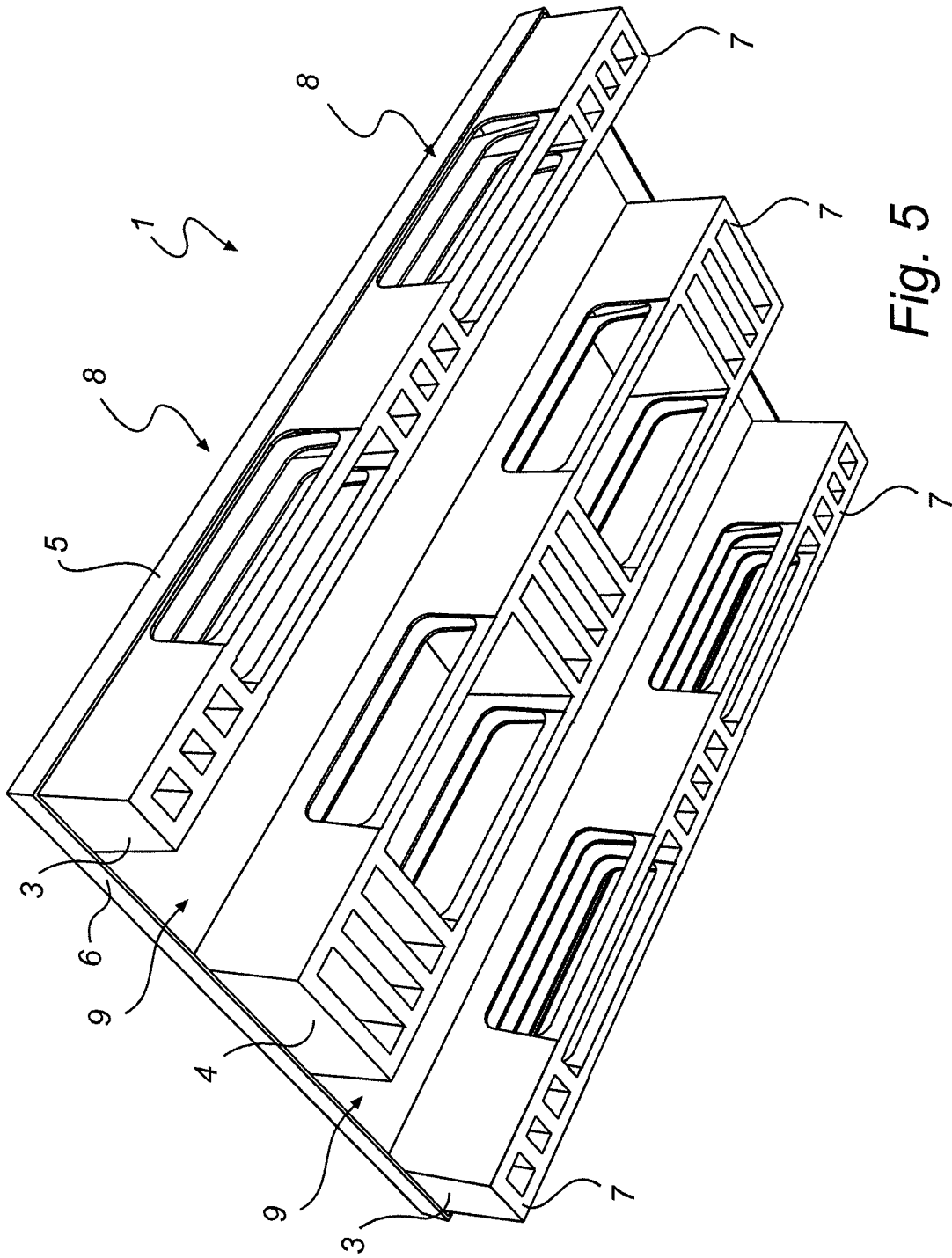
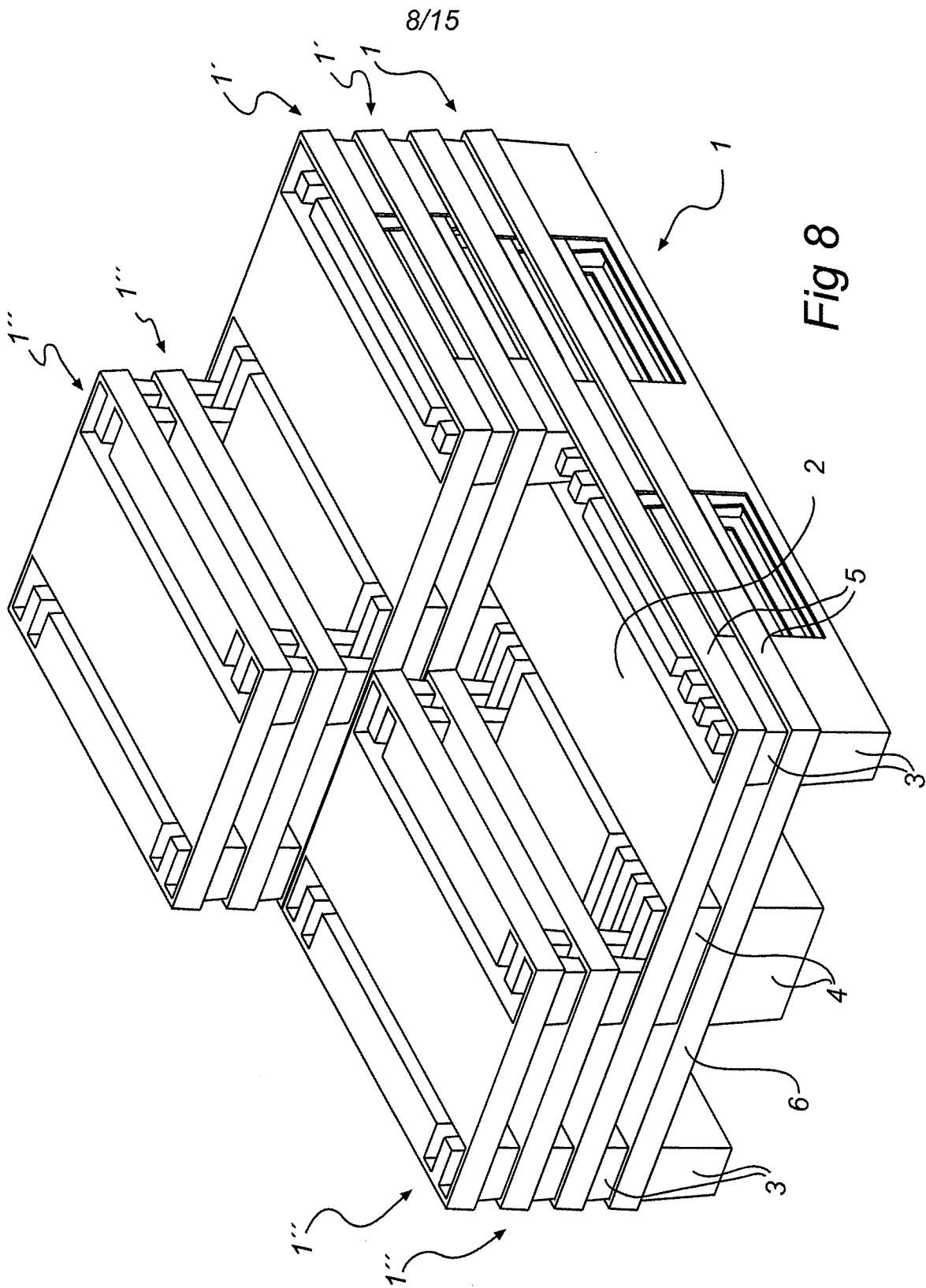

Fig. 5



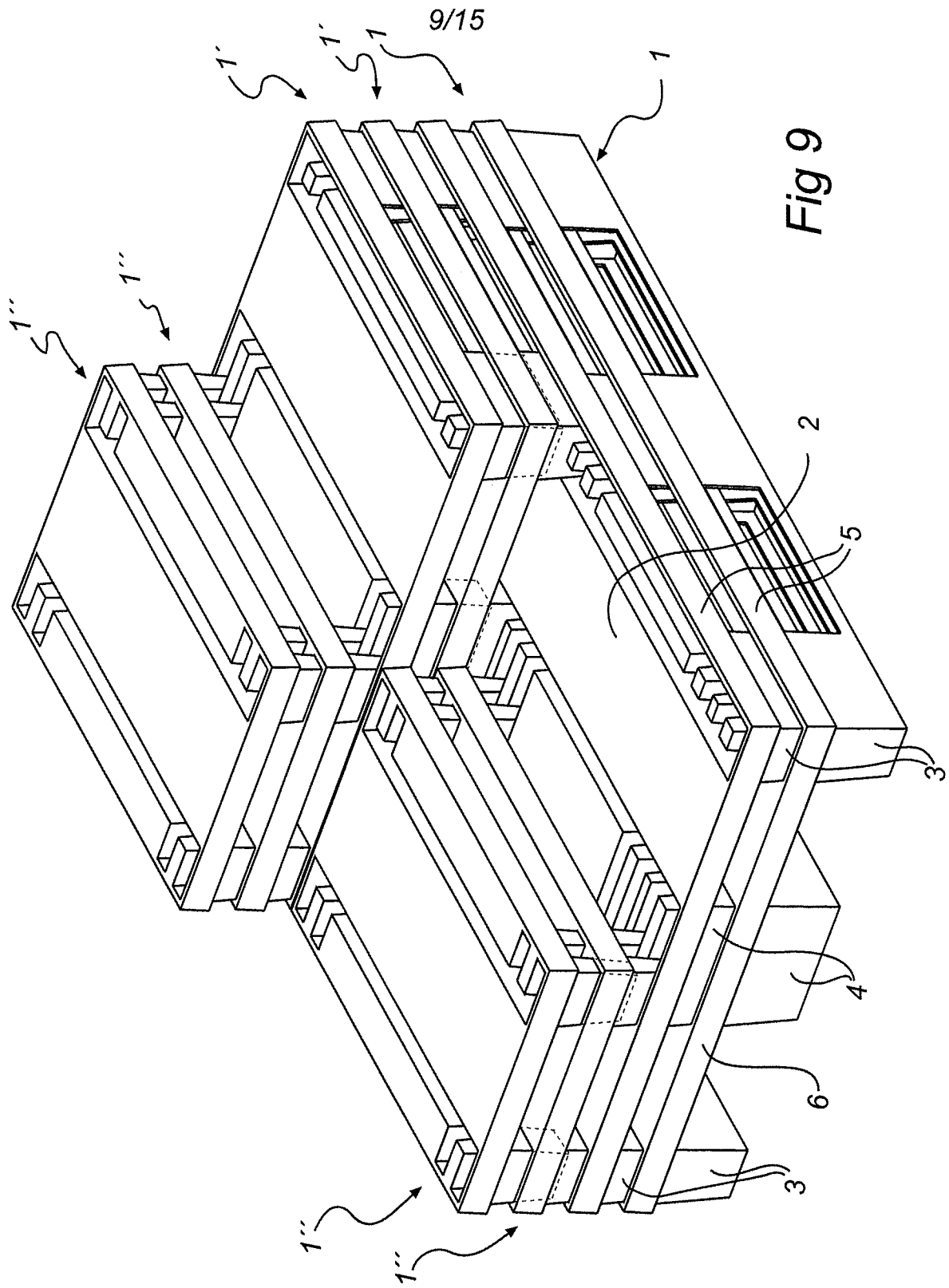
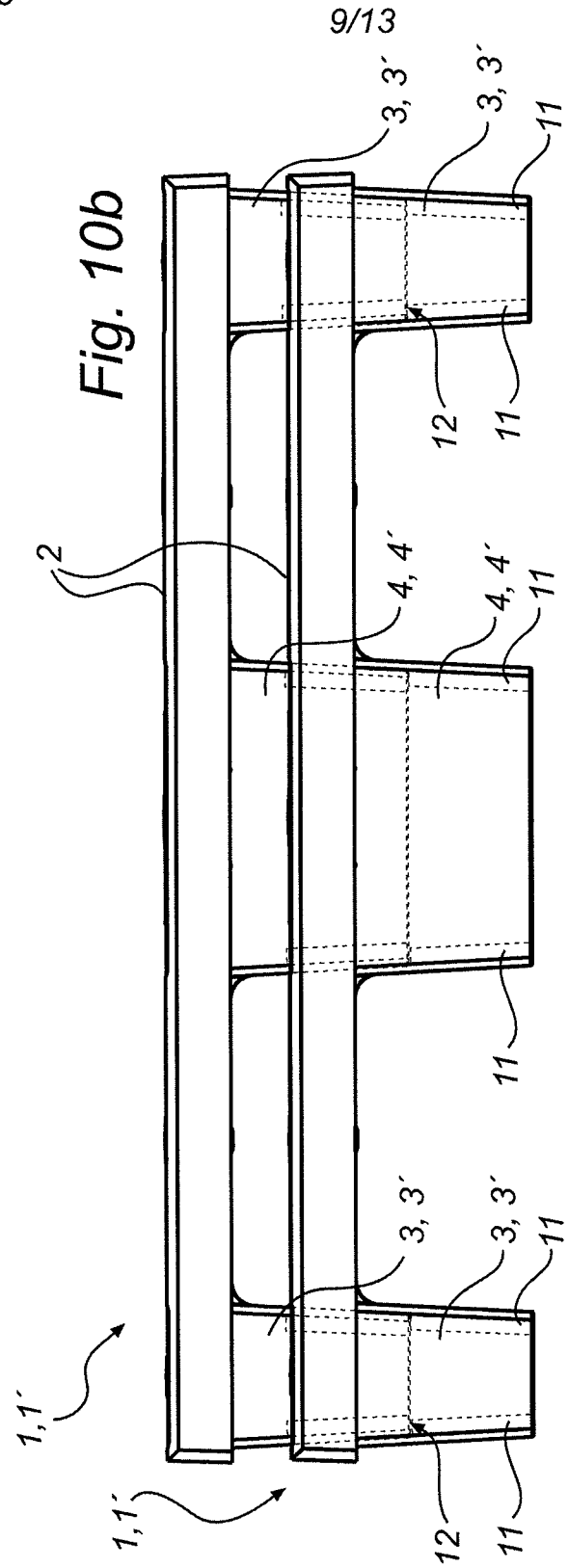
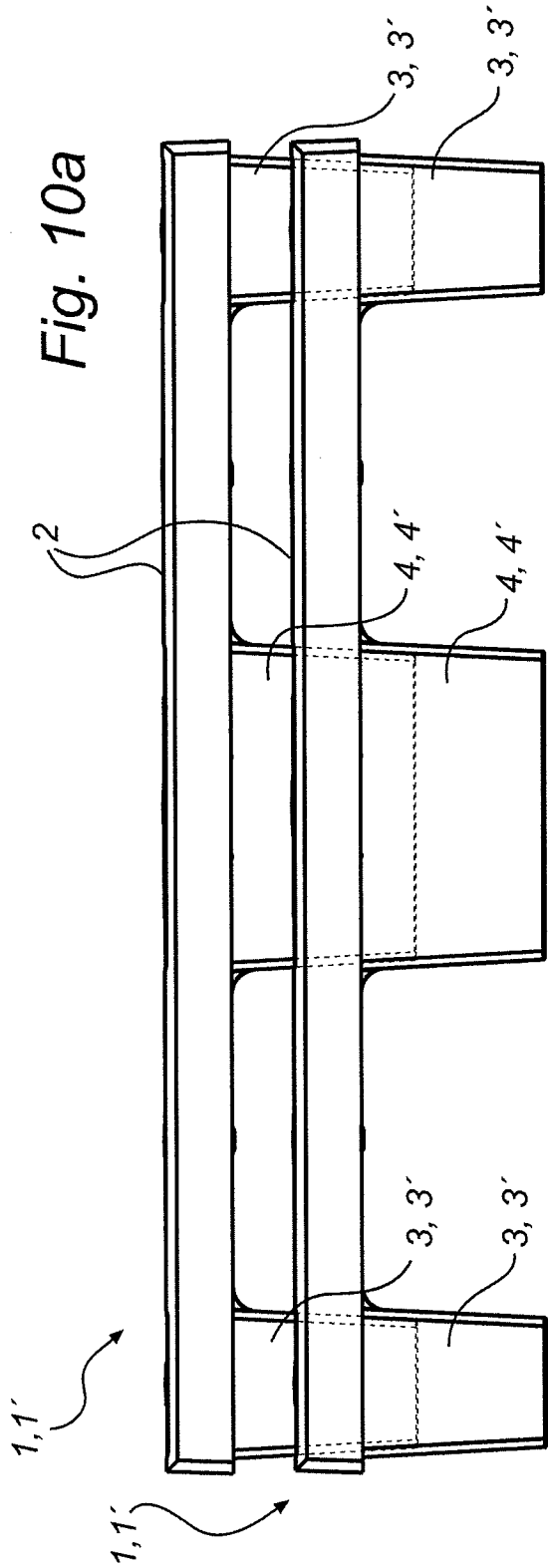
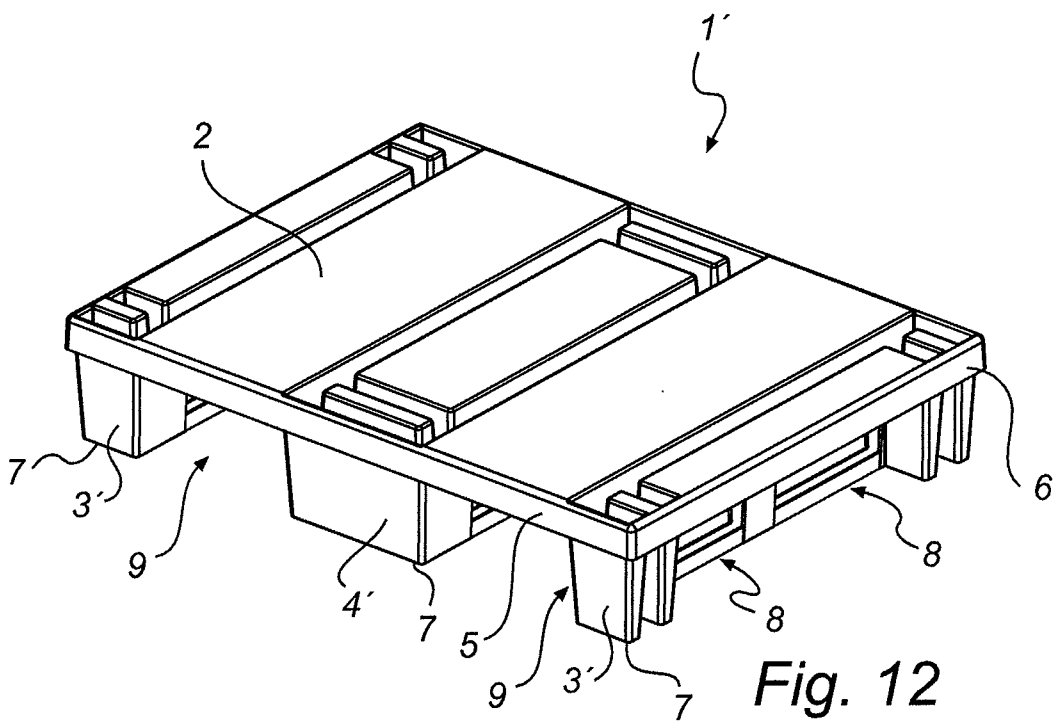
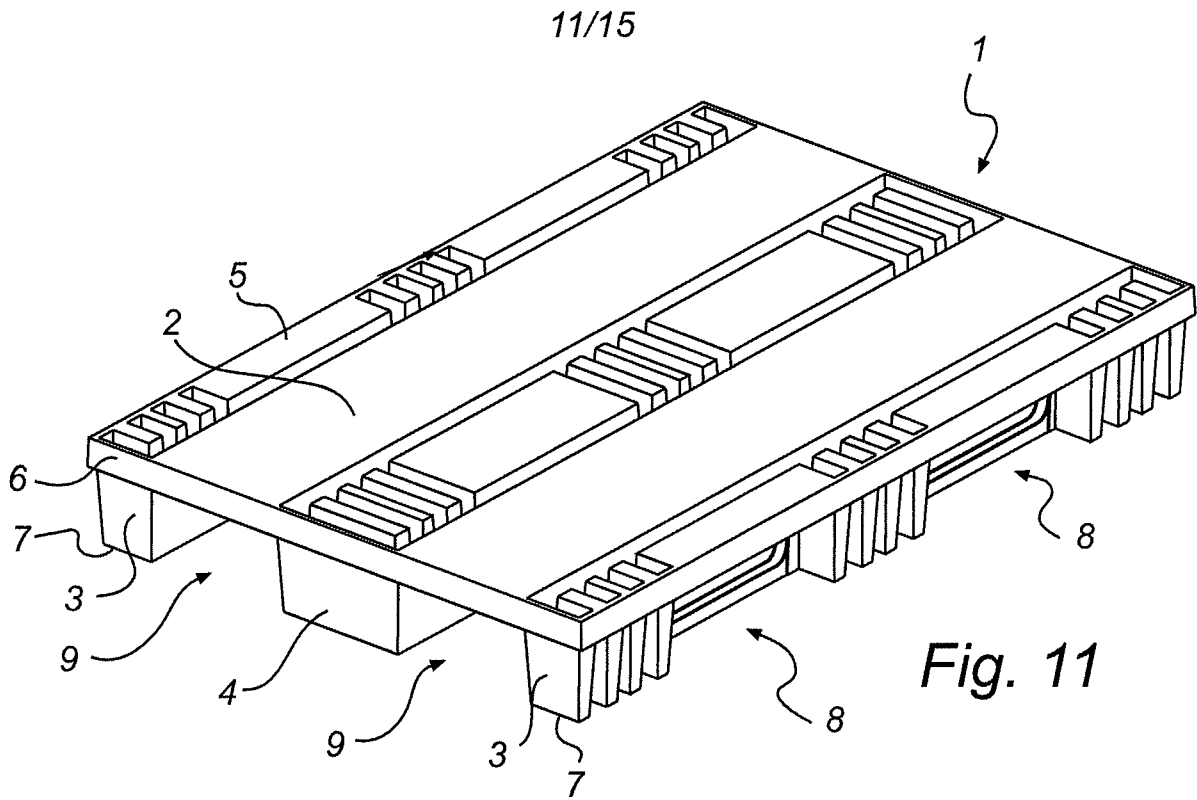

Fig 9

10/15





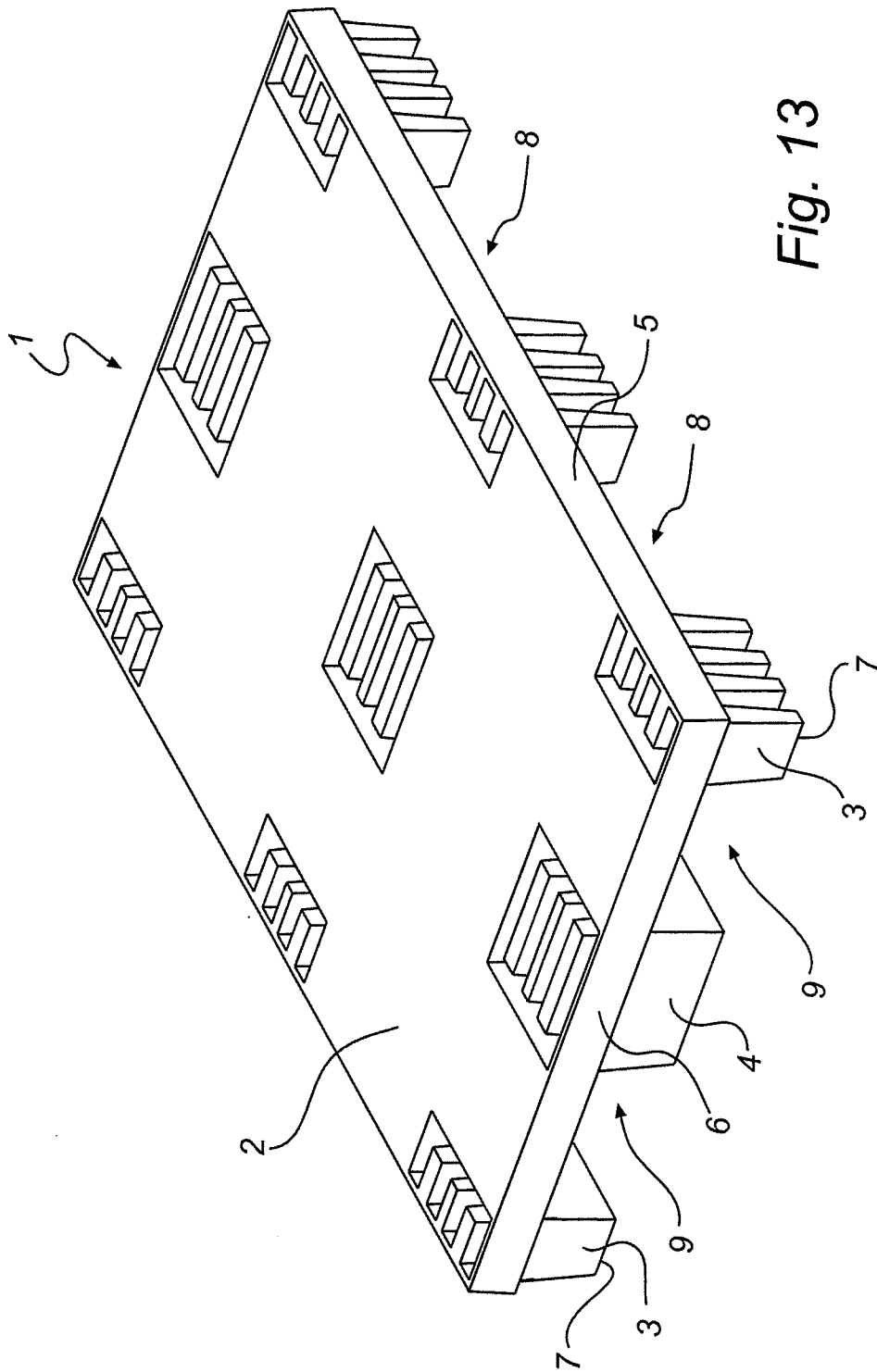

Fig. 13

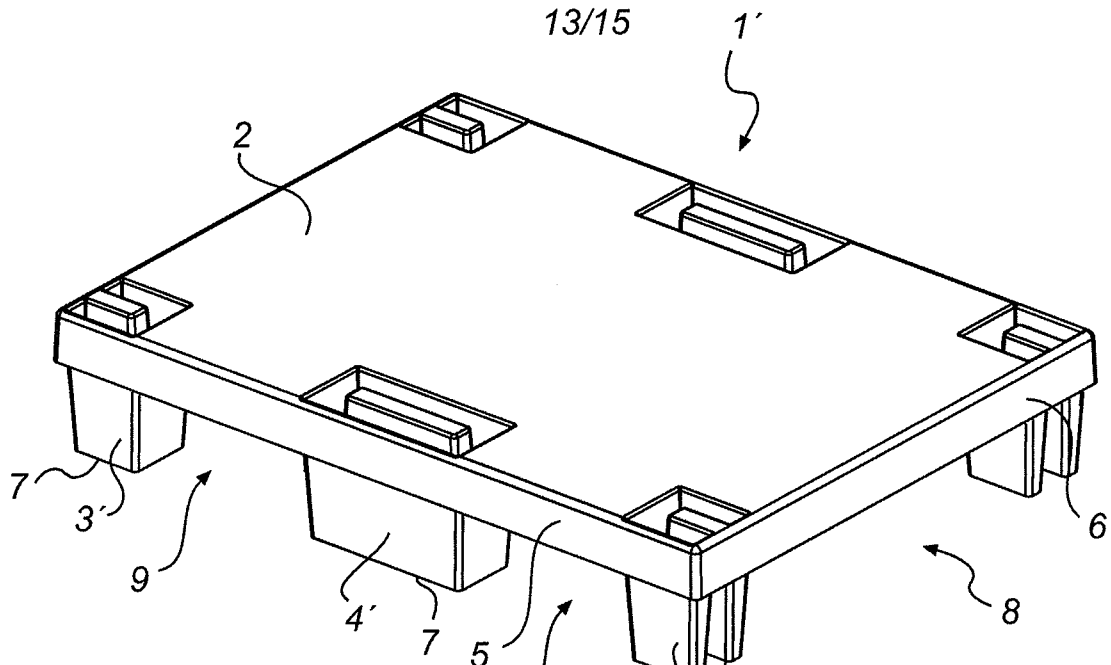

Fig. 14

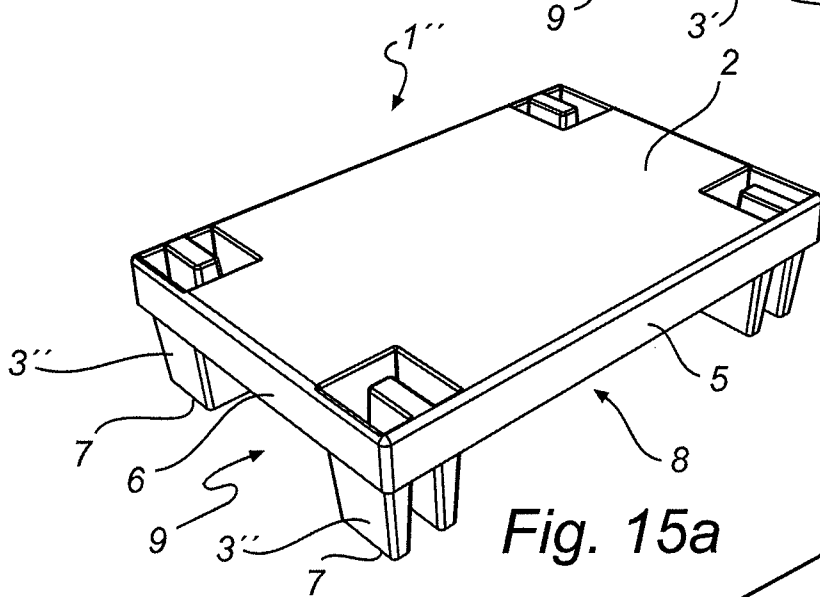

Fig. 15a

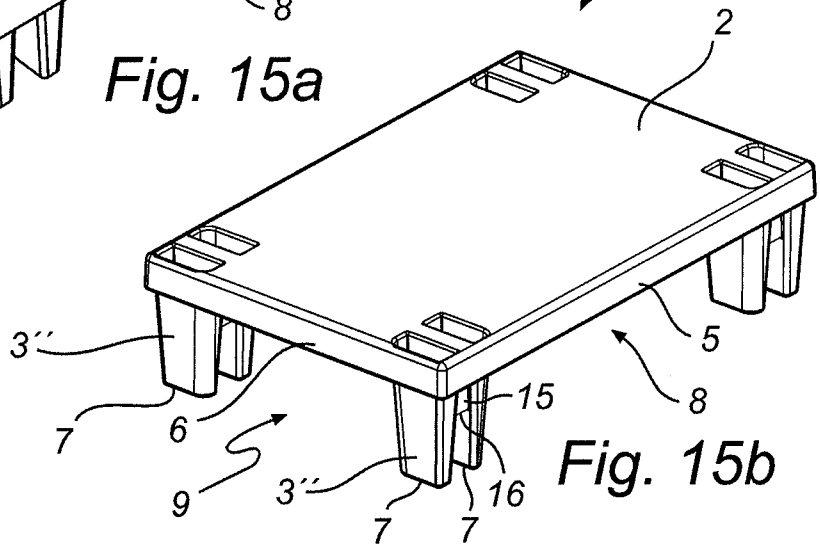
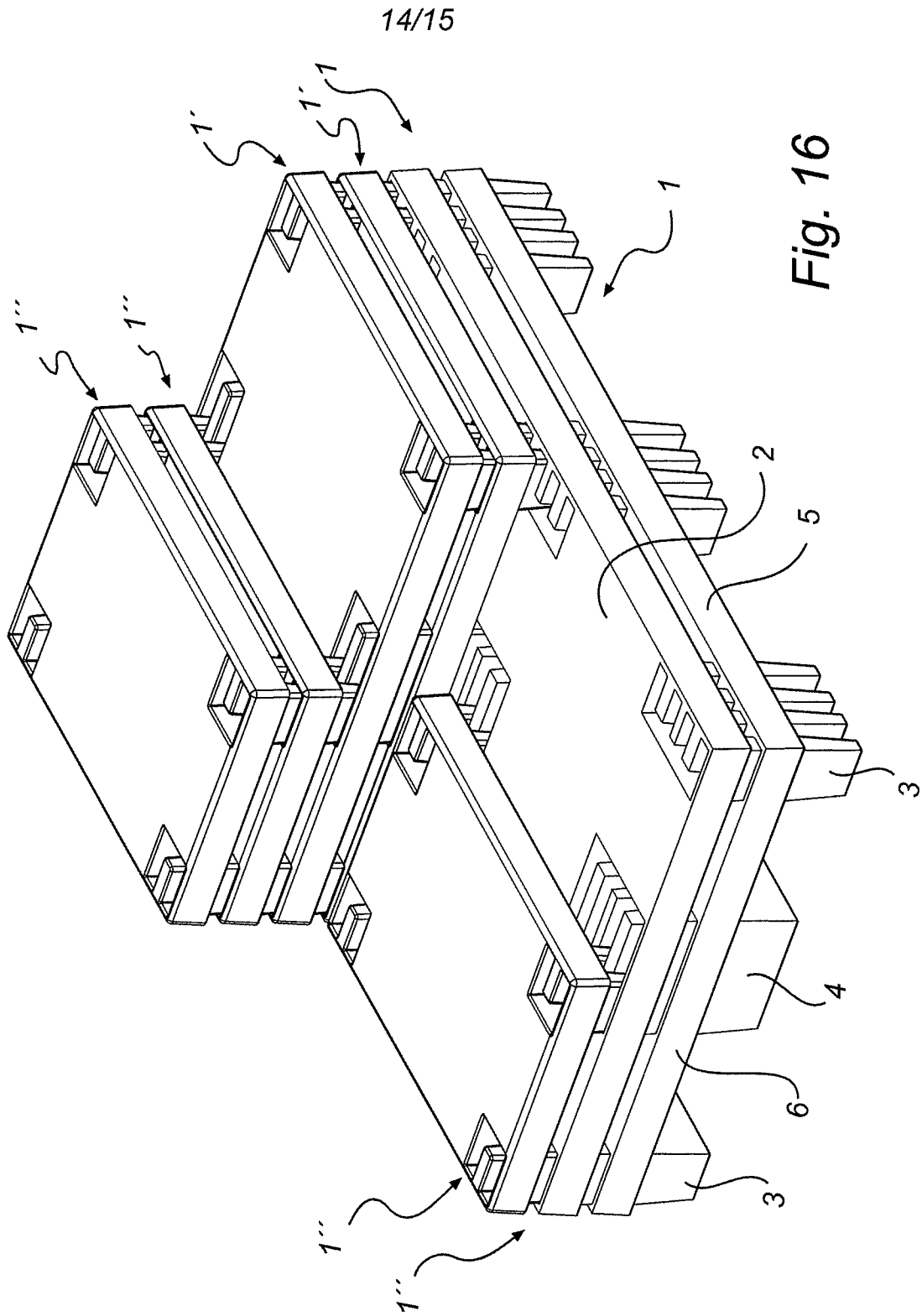

Fig. 15b



15/15

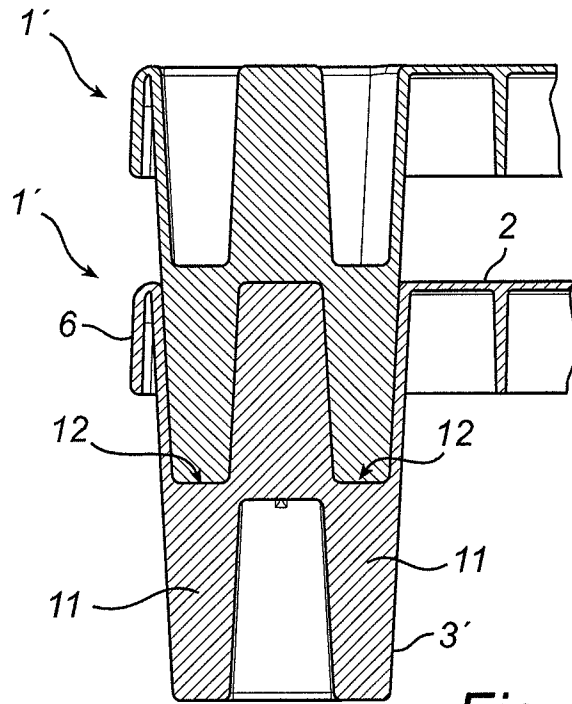

Fig. 17

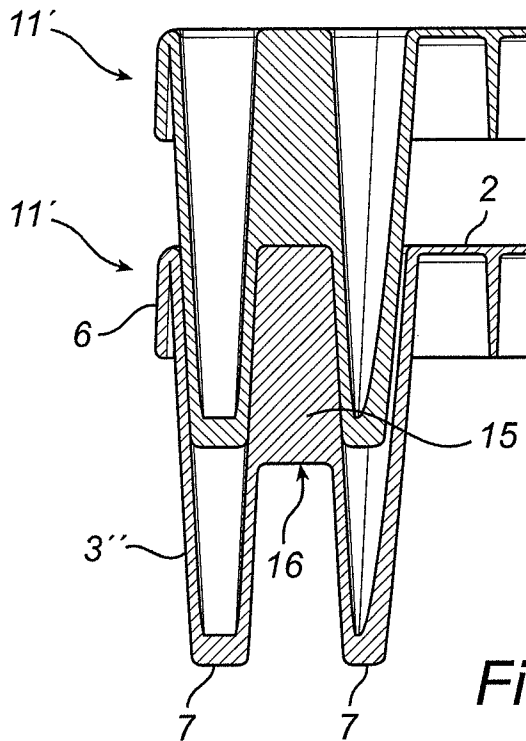

Fig. 18

INTERNATIONAL SEARCH REPORT

International application No.

PCT/SE2009/051369

A. CLASSIFICATION OF SUBJECT MATTER	
IPC: see extra sheet According to International Patent Classification (IPC) or to both national classification and IPC	
B. FIELDS SEARCHED	
Minimum documentation searched (classification system followed by classification symbols)	
IPC: B65D	
Documentation searched other than minimum documentation to the extent that such documents are included in the fields searched	
SE,DK,FI,NO classes as above	
Electronic data base consulted during the international search (name of data base and, where practicable, search terms used)	
EPO-INTERNAL, WPI DATA, PAJ	
C. DOCUMENTS CONSIDERED TO BE RELEVANT	
Category*	Citation of document, with indication, where appropriate, of the relevant passages
X	EP 0523737 A2 (SCHOELLER-PLAST S.A.), 20 January 1993 (20.01.1993), column 1, line 18 - line 23; column 1, line 30 - line 41; column 1, line 55 - line 58, column 2, line 1 - line 4, column 2, line 17 - line 25, column 3, line 1 -line 10, column 3, line 28 - line 33, column 4, line 5 - line 55, column 5, line 31 - line 58,
X	column 6, line 1 - line 8, figures 1-9, claims 1,4 --
X	US 20080011205 A1 (D. HAAF), 17 January 2008 (17.01.2008), figures 7-12, paragraphs (0055)-(0068)
A	--
<input checked="" type="checkbox"/>	Further documents are listed in the continuation of Box C.
<input checked="" type="checkbox"/>	See patent family annex.
* Special categories of cited documents:	"T" later document published after the international filing date or priority date and not in conflict with the application but cited to understand the principle or theory underlying the invention
"A" document defining the general state of the art which is not considered to be of particular relevance	"X" document of particular relevance: the claimed invention cannot be considered novel or cannot be considered to involve an inventive step when the document is taken alone
"E" earlier application or patent but published on or after the international filing date	"Y" document of particular relevance: the claimed invention cannot be considered to involve an inventive step when the document is combined with one or more other such documents, such combination being obvious to a person skilled in the art
"L" document which may throw doubts on priority claim(s) or which is cited to establish the publication date of another citation or other special reason (as specified)	"&" document member of the same patent family
"O" document referring to an oral disclosure, use, exhibition or other means	
"P" document published prior to the international filing date but later than the priority date claimed	
Date of the actual completion of the international search	Date of mailing of the international search report
25 March 2010	30 -03- 2010
Name and mailing address of the ISA/ Swedish Patent Office Box 5055, S-102 42 STOCKHOLM Facsimile No. +46 8 666 02 86	Authorized officer Anna Ahlander / MRo Telephone No. +46 8 782 25 00

INTERNATIONAL SEARCH REPORT

International application No.

PCT/SE2009/051369

C (Continuation). DOCUMENTS CONSIDERED TO BE RELEVANT		
Category*	Citation of document, with indication, where appropriate, of the relevant passages	Relevant to claim No.
X	WO 2007069034 A2 (INTER IKEA SYSTEMS B.V.), 21 June 2007 (21.06.2007), page 1, line 22 - line 23, figures 1-4, claim 1	18
A	--	1-17
X	US 6289823 B1 (G.R. KOEFELDA ET AL), 18 Sept 2001 (18.09.2001), figures 12-19	18
A	--	1-17
X	DE 10157417 A1 (REMAPLAN ANLAGENBAU GMBH), 5 June 2003 (05.06.2003), figures 21-26	18
A	--	1-17
X	DE 3217573 A1 (FURNIER- UND SPERRHOLZWERK J.F. WERZ JR. KG), 17 November 1983 (17.11.1983), page 4, line 12 - line 19; page 5, line 11 - line 19, figures 1-4	1,14,17
A	--	2-13,15,16
A	US 4690281 A (M. BERTHET), 1 Sept 1987 (01.09.1987), figure 1	1-17
A	GB 2368337 A (WAVIN B.V.), 1 May 2002 (01.05.2002), page 3, line 2 - line 4; page 6, line 2 - line 5, figures 1-10	1-17
	-- -----	

International patent classification (IPC)**B65D 19/24** (2006.01)**Download your patent documents at www.prv.se**

The cited patent documents can be downloaded:

- From "Cited documents" found under our online services at www.prv.se (English version)
- From "Anförda dokument" found under "e-tjänster" at www.prv.se (Swedish version)

Use the application number as username. The password is **GHDSKLZBVR**.

Paper copies can be ordered at a cost of 50 SEK per copy from PRV InterPat (telephone number 08-782 28 85).

Cited literature, if any, will be enclosed in paper form.

INTERNATIONAL SEARCH REPORT

International application No.
PCT/SE2009/051369

Box No. II Observations where certain claims were found unsearchable (Continuation of item 2 of first sheet)

This international search report has not been established in respect of certain claims under Article 17(2)(a) for the following reasons:

- 1. Claims Nos.:
because they relate to subject matter not required to be searched by this Authority, namely:

- 2. Claims Nos.:
because they relate to parts of the international application that do not comply with the prescribed requirements to such an extent that no meaningful international search can be carried out, specifically:

- 3. Claims Nos.:
because they are dependent claims and are not drafted in accordance with the second and third sentences of Rule 6.4(a).

Box No. III Observations where unity of invention is lacking (Continuation of item 3 of first sheet)

This International Searching Authority found multiple inventions in this international application, as follows:

See extra sheet

.../...

- 1. As all required additional search fees were timely paid by the applicant, this international search report covers all searchable claims.
- 2. As all searchable claims could be searched without effort justifying an additional fees, this Authority did not invite payment of any additional fees.
- 3. As only some of the required additional search fees were timely paid by the applicant, this international search report covers only those claims for which fees were paid, specifically claims Nos.:

- 4. No required additional search fees were timely paid by the applicant. Consequently, this international search report is restricted to the invention first mentioned in the claims; it is covered by claims Nos.:

Remark on Protest

- The additional search fees were accompanied by the applicant's protest and, where applicable, the payment of a protest fee.
- The additional search fees were accompanied by the applicant's protest but the applicable protest fee was not paid within the time limit specified in the invitation.
- No protest accompanied the payment of additional search fees.

Box III

The following separate inventions were identified:

1: Claims 1-17 directed to a system of multiple-use pallets that are stackable in one another.

2: Claims 18 directed to a multiple-use pallet comprising at least two supporting legs for supporting a load surface which supporting legs each have a supporting surface facing away from the load surface, where at least one of the supporting surfaces extends up to the load surface and form parts thereof.

The present application has been considered to contain 2 inventions which are not linked such that they form a single general inventive concept, as required by Rule 13 PCT for the following reasons:

Claim 1 relates to the problem of nesting empty pallets and create a system of pallets when the pallets have different length or/and width. This problem appears to be solved by having each pallet comprising a load surface with two mutually perpendicular sides which each have a certain length. The length of one side of the first pallet is a first integer multiple of the length of one side of the second pallet, and the length of the other side of the first pallet is a second integer multiple of the length of the other side of the second pallet. Any one of said first or second integer multiple is different from one. The pallets are stackable in one another.

Claim 18 relates to the problem of achieving a pallet that is provided with stable supporting legs, large load surface and low weight. This problem is solved by providing the pallet with hollow meander-formed supporting legs that extend up to the load surface and form parts thereof.

As both the problems and solutions are technically different, no single general concept can be formulated based on the technical features of the inventions. Consequently, the requirements of Rule 13.1 PCT are not met.

.../...

INTERNATIONAL SEARCH REPORT

International application No.
PCT/SE2009/051369

Box III

It was investigated under Rule 13.2 if any further feature, either in the claims or derivable from the description, could be considered as a same or corresponding feature, and could be considered a special technical feature establishing a technical link between the two groups of inventions.

No such features were identified.

Consequently, the two groups of inventions are not so linked as to form a single general inventive concept as required by Rule 13.1 PCT.

INTERNATIONAL SEARCH REPORT

Information on patent family members

International application No.

PCT/SE2009/051369

EP	0523737	A2	20/01/1993	AT	137463	T	15/05/1996
				AT	144955	T	15/11/1996
				DE	9218718	U	09/03/1995
				DE	59206159	D	05/06/1996
				DE	59207507	D	12/12/1996
				DK	669258	T	10/03/1997
				DK	0523737	T	10/06/1996
				EP	0669258	A,B	06/11/1996
				ES	2086589	T	01/07/1996
				ES	2095171	T	01/02/1997

US	20080011205	A1	17/01/2008	NONE			

WO	2007069034	A2	21/06/2007	AU	2006325093	A	21/06/2007
				CN	101336196	A	31/12/2008
				DK	176570	B	15/09/2008
				DK	200501763	A	14/06/2007
				EP	1973787	A	01/10/2008
				JP	2009519182	T	14/05/2009
				US	20090293776	A	03/12/2009

US	6289823	B1	18/09/2001	AU	6915100	A	13/03/2001
				US	20020017225	A	14/02/2002
				WO	0112509	A	30/08/2001

DE	10157417	A1	05/06/2003	NONE			

DE	3217573	A1	17/11/1983	NONE			

US	4690281	A	01/09/1987	CN	85108500	A	23/07/1986
				DE	3562212	D	26/05/1988
				DK	530585	A	17/05/1986
				EP	0183600	A,B	20/04/1988
				ES	8701658	A	01/03/1987
				FR	2573394	A,B	12/12/1986
				GR	852739	A	14/03/1986
				JP	61217362	A	26/09/1986
				PT	81500	A,B	31/07/1992

GB	2368337	A	01/05/2002	NL	1016493	C	01/05/2002
