



- (51) International Patent Classification:  
F23D 3/08 (2006.01) F23D 7/00 (2006.01)  
F23D 3/33 (2006.01)
- (21) International Application Number:  
PCT/US2014/051673
- (22) International Filing Date:  
19 August 2014 (19.08.2014)
- (25) Filing Language: English
- (26) Publication Language: English
- (30) Priority Data:  
61/959,181 19 August 2013 (19.08.2013) US  
61/967,524 21 March 2014 (21.03.2014) US
- (71) Applicant: **MASTERSON ENTERPRISES, INC.**  
[US/US]; 1419 W. Jeffrey Drive, Addison, IL 60101 (US).
- (72) Inventor: **MASTERSON, Daniel, J.**; C/o Masterson Enterprises, Inc., 1419 W. Jeffrey Drive, Addison, IL 60101 (US).
- (74) Agents: **WALTMIRE, Eric, R.** et al.; Erickson Law Group, PC, 1749 S. Maperville Rd., Suite 202, Wheaton, IL 60189 (US).

- (81) Designated States (unless otherwise indicated, for every kind of national protection available): AE, AG, AL, AM, AO, AT, AU, AZ, BA, BB, BG, BH, BN, BR, BW, BY, BZ, CA, CH, CL, CN, CO, CR, CU, CZ, DE, DK, DM, DO, DZ, EC, EE, EG, ES, FI, GB, GD, GE, GH, GM, GT, HN, HR, HU, ID, IL, IN, IR, IS, JP, KE, KG, KN, KP, KR, KZ, LA, LC, LK, LR, LS, LT, LU, LY, MA, MD, ME, MG, MK, MN, MW, MX, MY, MZ, NA, NG, NI, NO, NZ, OM, PA, PE, PG, PH, PL, PT, QA, RO, RS, RU, RW, SA, SC, SD, SE, SG, SK, SL, SM, ST, SV, SY, TH, TJ, TM, TN, TR, TT, TZ, UA, UG, US, UZ, VC, VN, ZA, ZM, ZW.
- (84) Designated States (unless otherwise indicated, for every kind of regional protection available): ARIPO (BW, GH, GM, KE, LR, LS, MW, MZ, NA, RW, SD, SL, ST, SZ, TZ, UG, ZM, ZW), Eurasian (AM, AZ, BY, KG, KZ, RU, TJ, TM), European (AL, AT, BE, BG, CH, CY, CZ, DE, DK, EE, ES, FI, FR, GB, GR, HR, HU, IE, IS, IT, LT, LU, LV, MC, MK, MT, NL, NO, PL, PT, RO, RS, SE, SI, SK, SM, TR), OAPI (BF, BJ, CF, CG, CI, CM, GA, GN, GQ, GW, KM, ML, MR, NE, SN, TD, TG).

**Declarations under Rule 4.17:**

— of inventorship (Rule 4.17(iv))

[Continued on next page]

(54) Title: SOLID FUEL BURNING SYSTEM AND METHOD

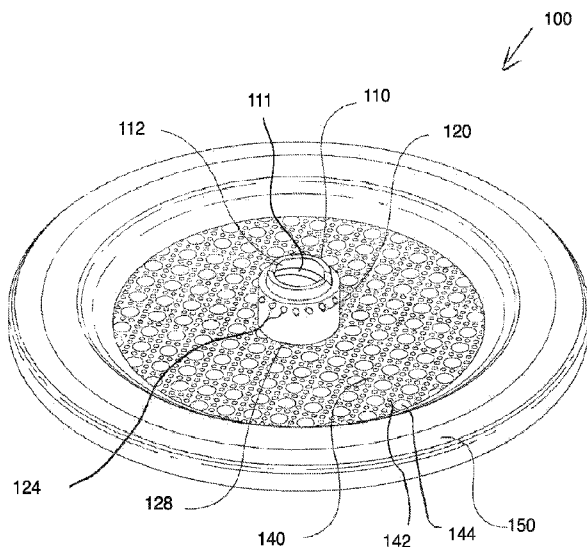

Fig. 1

(57) Abstract: A solid fuel burning system and method with a wick having a bridge is provided. The system has a melted wax reservoir, a melting grate, and the wick. The melting grate is configured to receive a solid wax. The melting grate located above at least a portion of the melted wax reservoir so that wax melted on the melting grate can be received into the melted wax reservoir. The wick has a perimeter wall, a hollow core, the bridge, and an upper exit opening in communication with the hollow core. The bridge extends across the hollow core between a first portion and a second portion of the perimeter wall. A solid fuel burning system and method with an electronic ignition system is also provided having a power source, a filament, and a filament support. The filament support positions the filament adjacent the wick or bridge within the hollow core.

**Published:**

— with international search report (Art. 21(3))

— before the expiration of the time limit for amending the claims and to be republished in the event of receipt of amendments (Rule 48.2(h))

## Solid Fuel Burning System and Method

This application claims the benefit of U.S. Patent Application No. 61,959,181, filed on 08/19/2013, and U.S. Patent Application No. 61/967,524, filed on 03/21/2014, each application  
5 naming Daniel J. Masterson as an inventor, and each of these applications is incorporated herein by reference in its entirety.

### FIELD OF THE INVENTION

The invention relates to fuel burners and more specifically systems for burning solid fuels,  
10 such as wax.

### BACKGROUND OF THE INVENTION

Typically wax is used as a fuel in traditional candles. Traditional candles transfer heat to melt the wax around a wick via radiation. The process delivers heat slowly and inefficiently resulting in a  
15 slow rate of melting the wax around the wick and creating the melt pool. Performance candles, candles that are used to drive a volatile active ingredient into the air, rely on developing a melt pool since the rate of active delivery is dependent on the size or surface area of the pool. Traditional candles can take four or more hours to create a melt pool of sufficient size to fill a typical room or area with its volatile active ingredient.

20 At the same time, because the flame size is limited and the resulting heat flux generated by the flame so small, the operating temperature of a candle melt pool is barely above the melt temperature of the wax, which limits the rate and the completeness of the volatile chemical delivery and limits the pallet of active ingredients that can be functional to those that work at lower temperatures.

Because of the small flame, slow melt pool development, and low operating temperature of the melt pool, performance candles suffer from sluggish and incomplete delivery. Performance candle formulators (like perfumers) are restricted to a limited breadth of ingredients that can be effectively used.

5 Further, traditional candles have flame sizes that are greatly limited. Candles used indoors are limited in size and in heat of the flame due to the creation of soot as the candle/wick system increases in size. As such products move outdoors, where soot can be accommodated, larger flames become increasingly difficult to create because larger wicks become difficult to ignite. This is due to the overall mass and heat capacity of the wick and wax, which makes it difficult or impossible to  
10 vaporize the fuel for ignition.

Indoor or traditional candle type products are therefore limited in flame size and heat delivery. The indoor use of candles can be used for lighting as well as delivery of a volatile active ingredient like fragrance, medicinal ingredients, or insect repellent (if used outdoors). Unfortunately, the flame size and heat limitations of the traditional wick and wax systems result in products that  
15 create low light and take exceptionally long times for the melt pool to develop. Since the active delivery is a function of both the wax/fuel melt pool size and operating temperature, the volatile active ingredient is slow to release and to be delivered to the surroundings. Even the Glade™ Scented Oil Candle that uses metal fins within the flame takes almost an hour to create a melt pool. In the outdoor use environment, this melt pool issue is exacerbated because of cooler air  
20 temperatures or the cooling effects of breezes.

Outdoor products rely on more flammable fuels like mineral oils or alcohols. Alcohol fuels like ethanol, isopropyl alcohol, and other short chain alcohols have recently been recalled due to their extreme flammability and ability to carry the fire without a wick. Mineral oil type fuels, like those used in yard torches, are acutely toxic to the respiratory system upon even the slightest

ingestion. In addition, the liquid fuels are prone to creating excessive soot and develop and deliver an oil refinery off odor.

The present inventor has recognized that waxes, including but not limited to paraffin, soy wax, palm wax, beeswax, and others, would make ideal fuels, especially for outdoor products that  
5 desire and require larger flames. Additionally, the present inventor has recognized that indoor applications could benefit from both light intensity improvements as well as faster wax pool development. The present inventor recognizes the need for a device that allows for faster wax pool melting and increased heat production.

Further, wicks or wick material often function as a filter and, like filters, are prone to fouling  
10 or clogging resulting from prolonged use or use with “dirty” filtrate (or fuel in the case of wicks). Most wicks are consumable and are not plagued by fouling or clogging; yet the phenomenon presents itself and can be dangerous as carbon pills form at the end of consumable wicks.

The present inventor has recognized that the benefits of a reusable or permanent wick are many and varied and include, but are not limited to, flame control, flame staging, and, in some  
15 applications, creating flames of unique geometry, hotter flames, larger stable flames, and less soot. However, reusable wicks are prone to clogging or fouling by the fuel used – especially fuels that contain higher levels of longer chain hydrocarbons (products like waxes or paraffin). These kinds of fuel with repeated use can lead to build-up of varnish, tar, carbon deposits, and other materials that can prevent the liquid fuel from flowing through the wick material, which results in diminished  
20 performance (smaller flames) and ultimately complete failure. In effect, the chemical nature of hydrocarbon fuels and their natural inclusion of longer chain components (even at very low levels) has heretofore made using permanent or reusable wicks difficult or practically impossible.

The present inventor has recognized the need for a device that allows reusable or permanent wicks while diminishing or eliminating the cumulative effects of fouling or clogging caused by hydrocarbon fuels.

Moreover, the present inventor has recognized that unlike traditional candles with a consumable wick, reusable and permanent wick candles offer the user the option to make larger and more stable flames, to create wax burners that shed more light, to create candles that produce larger and warmer melt pools that in turn more effectively deliver a volatile ingredient to the environment, and to repeatedly operate the system with no waste.

However, since the reusable or permanent wick remains with the burner apparatus, consideration is needed for preparing the wick for reuse. The present inventor has recognized that when the wick is barren of any fuel, it may require priming. The present inventor has recognized that priming must be enough to allow easy ignition without taking too long to ignite or without flooding the point of ignition. Then that first ignition point must provide enough heat to the surrounding wax to stoke the developing flame without melting so much wax that the melted wax restricts or even douses the developing flame. The present inventor has recognized that an imbalance of both the priming and stoking stages of the developing flame can result in starving the flame or in partially or completely flooding the first ignition.

The present inventor has recognized the need for a solid fuel, such as solid wax structure that repeatedly and reliably offers a natural priming location for wick ignition and then automatically manages the stoking stage to allow uninhibited and full development of the desired flame. Further, the present inventor recognized the need for a device that provides a main wax portion that is to be melted by the flame and used through complete melt and combustion.

The present inventor recognized that some permanent wicks can be hard to ignite, especially as the cumulative ignitions or uses increases above 20 to 40 ignitions. Often times, the time to ignite

can reach in excess of 40 seconds. This makes a reusable wick difficult to ignite with a lighter and very difficult or impossible to ignite with matches. One way to make it easier to ignite is to expose more wick. However, this makes the resulting flame too tall and often prone to generating soot. Therefore there is a trade-off between ease of ignition and size, safety, and suitability of the flame.

5 While larger flames may be accommodated for outdoor products like a torch or fire pot, the large flame and propensity to soot is unacceptable for indoor applications.

The present inventor recognized the need for a system that reduces both the time to ignition as well as the operating flame height of the resulting flame. Further, the present inventor recognized the need for the reduction in ignition time and flame height to be maintained and/or not to be  
10 deteriorated or significantly altered through successive uses, such as in some case above 20 or above 50 ignitions.

Certain candles are composed of a wax mass within which a cotton or other consumable material wick passes through the wax mass and exposing the uppermost portion of the wick for ignition. The wick used in such candles is typically pre-primed with wax to enable the first ignition.  
15 The art of candle making has, over thousands of years, been focused on perfecting the delicate balance of the wax fuel and the consumable wick. Once lit the wick delivers the melted wax to the flame and, as the fuel is used, the wick burns off (often causing wisps of soot) and the flame travels down to meet the fuel. A candle, however, requires an external ignition source, which is typically a match or a lighter. Because of this, a candle is prone to several inconveniences and dangers including  
20 but not limited to (1) burn hazards, especially if the wick takes too long to ignite; (2) inconvenience of not having an ignition source available to use as it may be misplaced, out of fuel, or difficult for itself to ignite; and, (3) in some cases, as in jar candles, the wick is difficult to reach and becomes dangerous to light or requires a specific or special kind of lighter (like a wand lighter), these jar style candles and other "sunk" candle designs are specially prone to burn or hot wax spilling hazards.

The present inventor recognized that it would be desirable to have a device to ignite a candle or similar wax burning assembly that is safer and more convenient. In particular, a device where the ignition mechanism or system is neither obtrusive to the flame nor obvious or visible.

The present inventor recognized that the use of a fixed position system, like a hot filament,  
5 on traditional candles will not work repeatedly since the point of ignition (the consumable wick) moves as the candle is used and the fuel is depleted. This makes the candle unable to be re-lit repeatedly and throughout the life of the candle with a fixed position system. Furthermore, the addition of any ignition system upon a traditional candle wick will obstruct the flame, be obvious or too visible, or both. Therefore, the present inventor recognized it would be desirable for a solid fuel  
10 burning system to have a reliable, convenient, and repeatable device for ignition.

Kerosene and propane heaters use a filament or piezo electric techniques to promote ignition without needing a match, lighter, or eternal flame. However, kerosene, propane, butane and other fuels that use such techniques are flammable, with fire ratings of 3 and 4, and volatile liquids or gases and require little energy to reach an ignition point. Furthermore, these fuel types are  
15 incapable of flooding or extinguishing their own flame. The use of a filament or piezo electric techniques have not been applied to candles or other wax burning assemblies previously for at least the following reasons recognized by the inventor: (1) solid wax is a non-flammable fuel, with a fire rating of 1, and, as such, imposes several thermodynamic challenges, such as: (a) the solid wax fuel must go through two phase transitions, from solid to liquid, and then from liquid to vapor, in order  
20 to ignite, (b) the solid wax fuel needs to reach a much elevated ignition temperature for ignition; (2) due to the solid wax fuel's non-flammable nature, an assembly using solid wax is prone to dowsing its own flame out with its own fuel (flooding); and (3) high temperature exposure of a filament to oxygen causes reduced life and increased frailty of the filament, making extended use difficult. The

present inventor recognized a need to overcome these drawbacks and provide other benefits in a wax burning system with electric ignition.

## SUMMARY OF THE INVENTION

5           A wax burning system with a wick having a bridge is disclosed. The system has a melted wax reservoir, a melting grate, and the wick. The melting grate is configured to receive a solid wax. The melting grate located above at least a portion of the melted wax reservoir so that wax melted on the melting grate can be received into the melted wax reservoir. The wick has a perimeter wall, a hollow core, the bridge, and an upper exit opening in communication with the hollow core. The bridge has  
10 a first end and a second end. The first end joins with a first portion of the perimeter wall. The second end joins with a second portion of the perimeter wall. The bridge extends across the hollow core between the first and second portions of the perimeter wall. The hollow core forms a burn chamber extending above the melting grate. The hollow core is sized to stage vapor phase fuel below the flame adjacent the upper exit opening to create a partially oxygen deprived condition at  
15 the flame on the wick.

          A method of operating a wax burning system is disclosed. A solid fuel is located on a melting grate adjacent to a wick. The solid fuel has a priming section. The wick has a perimeter wall, a hollow core, a bridge, and an upper exit opening in communication with the hollow core. The bridge extends across the hollow core between a first portion and a second portion of the perimeter  
20 wall. The priming section is positioned adjacent to the bridge. At least a portion of the priming section is heated with an ignition source so that a portion of the priming section melts and falls onto the bridge. The bridge is ignited when the bridge comprises a sufficient amount of fuel to support a flame. The flame travels along the bridge to the perimeter wall and the flame is transferred from the bridge to the perimeter wall of the wick.

A wax burning system having an electronic ignition system is disclosed. The system has a melted wax reservoir, a melting grate, a wick, and the electronic ignition system. The melting grate is configured to receive a solid wax. The melting grate is located above at least a portion of the melted wax reservoir so that wax melted on the melting grate can be received into the melted wax reservoir.

5 The wick has a hollow core and an upper exit opening in communication with the hollow core. The hollow core forms a burn chamber extending above the melting grate. The electronic ignition system has a power source, a filament, and a filament support. The filament is attached to the filament support. The filament support positions the filament adjacent the wick within the hollow core. The filament is configured to receive power from the power source and to generate heat.

10 A method of operating a wax burning system with an electronic ignition system is disclosed. a solid fuel is located on a melting grate adjacent to a wick. The solid fuel has a priming section. The wick has a hollow core. The priming section is positioned adjacent the wick. At least a portion of the priming section is heated with a filament adjacent the wick so that a portion of the priming section melts and falls onto the wick. The filament is within the hollow core of the wick. The wick is ignited  
15 with heat from the filament when the wick comprises a sufficient amount of fuel to support a flame and when the fuel reach an ignition temperature.

Numerous other advantages and features of the present invention will become readily apparent from the following detailed description of the invention and the embodiments thereof, from the claims and from the accompanying drawings.

20

## **BRIEF DESCRIPTION OF THE DRAWINGS**

Figure 1 is a perspective view of one embodiment of a fuel burning system of the invention.

Figure 2 is a sectional side view of a second embodiment of a fuel burning system of the invention.

Figure 3 is a perspective view of the fuel burning system of figure 1 with certain components not shown.

Figure 4 is a side view of an embodiment of a wick from the system of figure 1 shown in a flattened position.

5 Figure 5 is a perspective view of the system of figure 1 with a solid fuel shown.

Figure 6 is a top view of the system of figure 5.

Figure 6A is a top view of the system of figure 5 with multiple bridges shown.

Figure 7 is a sectional side view of the system of figure 6 taken along the line 7—7 of figure  
6.

10 Figure 8 is a sectional side view of embodiment of the fuel burning system taken from a view similar to that of figure 7.

Figure 9 is a sectional side view of the system of figure 6 taken along line 9—9 of figure 6.

Figure 10 is a sectional side view from figure 7 with the solid fuel partially melted.

Figure 11 is a perspective view of the system of figure 2 with the reservoir not shown and  
15 with multiple solid fuel units shown.

Figure 12 is a detailed perspective view of the solid fuel of figure 5.

Figure 13 is a front view of the solid fuel of figure 12.

Figure 14 is a bottom view of the solid fuel of figure 12.

Figure 15 is a top view of the solid fuel of figure 12.

20 Figure 16 is a rear view of the solid fuel of figure 12.

Figure 17 is a left side view of the solid fuel of figure 12.

Figure 18 is a sectional side view of the solid fuel of figure 12 taken along line 7—7 of figure  
6.

Figure 19 is a front view of the solid fuel of figure 12.

Figure 20 is a side view of a portion of the fuel burning system of figure 2.

Figure 21 is a side view of a portion of the fuel burning system of figure 2 in a different state of operation.

Figure 22A is a perspective view of a third embodiment of the fuel burning system, with  
5 certain components not shown.

Figure 22B is a side view of the wick of figure 22A shown in a flattened position.

Figure 22C is a top view of the wick and wick sheath of figure 2.

Figure 22D is a top view of a third embodiment of a wick and a wick sheath configuration.

Figure 22E is a top view of a fourth embodiment of a wick and a wick sheath configuration.

10 Figure 22F is a top view of a fifth embodiment of a wick and a wick sheath configuration.

Figure 22G is a top view of a sixth embodiment of a wick and a wick sheath configuration.

Figure 23 is a side view of a seventh embodiment of a wick.

Figure 24 is a side view of an eighth embodiment of a wick.

Figure 25 is a side view of a ninth embodiment of a wick.

15 Figure 26 is a side view of a tenth embodiment of a wick.

Figure 27 is a side view of an eleventh embodiment of a wick.

Figure 28 is a side view of a twelfth embodiment of a wick.

Figure 29 is a perspective view of the system of figure 1 with an electronic ignition system  
and with an alternative embodiment wick.

20 Figure 29A is a perspective view of the system of figure 29 with a base and certain other  
components shown.

Figure 30 is a perspective view of the system of figure 1 with an electronic ignition system.

Figure 31 is a top view of the system of figure 30 with the solid fuel shown.

Figure 32 is a sectional side view of the system of figure 29, with a solid fuel shown and taken along a line similar to line 7—7 of figure 6.

Figure 33 is a sectional side view of the system of figure 30 taken along a line similar to line 7—7 of figure 6.

5 Figure 34 is a side view of components of the electronic ignition system and melting grate of figure 29.

Figure 35 is a circuit diagram of one embodiment of a circuit of the electronic ignition system.

Figure 36 is a perspective view taken from figure 29 with granular pourable wax shown.

10 Figure 37 is a top view of thirteenth embodiment wick.

Figure 38 is a top view of a fourteenth embodiment wick.

Figure 39 is a top view of a fifteenth embodiment wick.

Figure 40 is a top view of a sixteenth embodiment wick.

Figure 41 is a top view of a seventeenth embodiment wick.

15 Figure 42 is a perspective view an alternative embodiment wick with a hollow starter wick and a filament of the electronic ignition system.

Figure 43 is a perspective partial view of a portion of an alternative embodiment wick, a start wick, and a filament of the electronic ignition system.

## 20 DETAILED DESCRIPTION

While this invention is susceptible of embodiment in many different forms, there are shown in the drawings, and will be described herein in detail, specific embodiments thereof with the understanding that the present disclosure is to be considered as an exemplification of the principles of the invention and is not intended to limit the invention to the specific embodiments illustrated.

**System Overview.** Figure 1 shows an embodiment of a solid fuel burner system 100. The burner system 100 comprises a hollow-core wick 110, a burn chamber 112, a wick sheath 120, a melting grate 140, and a fuel reservoir 150, such as a bowl or basin. The wick comprises at least one bridge 111. Figure 2 show a second embodiment 200 of the burner system 100 of figure 1 with an alternative embodiment hollow-core wick 130 and an inner wick support ring 160. The wick 130 has a bridge 113. The hollow-core wick 130 of figure 2 is substituted for the hollow-core wick 110 of figure 1.

In general operation, a solid fuel, such as solid fuel 280, is placed on the melting grate. The wick is lit and the resulting flame 115 begins to heat the solid fuel causing it to melt. The melted fuel flows through the melting grate and into the fuel reservoir. The melted fuel is drawn into the wick to continue fueling the flame at the wick. The flame transmits heat to the solid fuel in at least two ways. First, heat from the flame is transmitted through the ambient air to the solid fuel. Second, heat is thermally transferred through the wick sheath and the melting grate to the fuel which is in contact with the melting grate. In some arrangements, wax may fall directly on the wick to prime the wick during initial operation until fuel is drawn into a bottom portion of the wick for feeding the flame at the top of the wick.

The reservoir 150 comprises a curved shape having a bottom 152 with upwardly curving sides 154, 156. The width of the melting grate 140 is sized to contact the sides 154, 156 of the bowl to position the bottom 148 of the melting grate 140 a pre-defined distance from the bottom of the reservoir. The volume of space between the bottom 152 of the reservoir 150 and the bottom 148 of the melting grate 140 is the lower fuel reservoir area 158.

The melting grate is suspended above at least the lower most portion of the bottom 152 of the reservoir 150. The bowl or basin may comprise other shapes other than curved, for example the bottom may be flat with obliquely angled side walls for intersecting with the melting grate.

The top 146 of the melting grate establishes a support surface for the wick system 170 and for solid fuel 201. Melting grate comprises a plurality of holes 142, 144 that allow melted fuel, such as melted wax to travel from the top surface of the melting grate down into the reservoir. The holes may be different sizes as that there are larger holes 144 and smaller holes 142. The wick system 170  
5 comprises a wick, such as wick 110 or 130, the wick sheath 120, and optionally the wick support ring 160. The wick system 170 creates a burn chamber 172 within the hollow-core wick 130 and bounded by the wick sheath.

The hollow-core wick 130 has an upper surface 132 and a lower surface 138. The upper surface 132 of the wick may comprise a plurality of peaks 135 and valleys 131. The wick sheath has  
10 an upper surface 122, and a lower surface 128. The wick support ring 160 has an upper surface 162 and a lower surface 168. The lower surfaces 168, 138, 128 of each of the wick support ring 160, the wick 130, and the wick sheath 120 are supported on the upper surface of the melting grate 140. The wick system 170 may be placed on the melting grate in any particular location. In some  
15 embodiments, the wick system is centered on the melting grate. In some embodiments, the melting grate is 4.25 inches in diameter, but many other sizes are also possible. Each of the wick sheath 120, the wick 130, and the wick support ring 160 comprises a cylindrical shape, however, in some embodiments, each may comprise other shapes such as such a shown and described in figures 22C-22G and 37-41.

In some embodiments, the inside surface 136 of the wick sheath 120 is in contact with the  
20 outside surface of the wick 130 and the inside surface 136 of the wick 130 is in contact with the outside surface of the wick support ring 160. In some embodiments, the inside surface 126 of the wick sheath 120 is in close proximity but not in surface-to-surface contact with the outside surface of the wick 130 and the inside surface 136 of the wick is in close proximity with the outside surface of the wick support ring 160. The close proximity may comprise distances in the range of about .001

of an millimeters to about 5 millimeters. In the embodiment shown in figure 2, the wick support ring is shorter than the wick sheath, which is shorter than the wick.

In some embodiments, a melting plate replaces the melting grate. The melting plate does not have any holes and the wick 130 is fed through lower holes (not shown) in the wick sheath.

5 In some embodiments, the reservoir is arranged to be positioned relatively close to the wick system to promote fast melt pool creation. The shape of the reservoir allows for a falling of melted wax toward the flame. The wax systematically melts from heat conduction, typically from the melting grate or a plate supporting the wick system. This is done by creating a shape that shifts the center of gravity of the melted wax toward the wick system as the wax melts.

10 The wick sheath comprises a plurality of air intake apertures or holes 124. The holes 124 are spaced apart about the circumference of the wick sheath. The holes are located adjacent to the upper surface 122 of the wick sheath 120. In some embodiments, the holes are located in the top half or top quarter of the height of the wick sheath. In some embodiments, the holes are 0.06 inches in diameter and allow air into the burn chamber. The holes 124 allow air to be pulled through the porous wick and into the burn chamber. The air intake holes allow an increased amount of oxygen to be introduced into the burn system thereby resulting in a higher burning/operating temperature.

15 The number and size of air intake holes 124 in the wick sheath affects the burn performance of the wick system 170. For example, the flame can be reduced by utilizing fewer holes or no holes, thereby reducing or starving the combustion of oxygen. On the other end of the spectrum, if the number and/or size of the holes are too great, too much oxygen will be allowed and the flame will be too large for its intended use. The number of holes will affect the stoichiometry of the combustion, generally by using oxygen as the limiting reactant to make larger, soot free, stable flames. Finally, if the holes are too large and expose too much of the porous wick material, the exposed side of the wick at the hole could ignite. In some embodiments, it is preferred that the holes

be less than 1/8 of an inch in diameter. In some embodiments, it is further preferred that the holes be less 1/16 inch in diameter. In one embodiment, the wick sheath comprises at between 2 and 10 apertures spaced apart equally about the circumferential outer side wall of the wick sheath.

In some embodiments, the wick sheath may comprise non-porous material such as metal, such as aluminum, copper, steel, iron, nickel, or a combination thereof. In some embodiments, the wick sheath may comprise material that has a lesser heat conductivity than metal but will survive a flame, such as ceramic, stone, refractory materials, glass, or a combination thereof. The inner wick support ring may comprise the same types of material just described for the wick sheath. The wick support ring is optional and is provided to maintain the shape of upstanding the wick adjacent or against the wick sheath. Some wick materials do not require a wick support ring for maintaining the wick's shape. The reservoir 150 may comprise wood, glass, ceramic, metal, and high melting resin. In some embodiments, the wick is comprised of ceramic fiber paper, such as Fiberfrax® Ceramic Paper 970A manufactured by Unifrax LLC of Niagara Falls, NY. In some embodiments, the wick is comprised of one or more of ceramic fiber paper, sintered glass, porous metals, porous ceramics, capillary glass, capillary metal, porous rock, metal weave, fiberglass, fiber glass cloth, refractory foam, refractory roll board, refractory tissue, refractory foam, refractory paper, refractory felt, refractory blanket, refractory tissue, carbon fiber woven cloth, and carbon composite.

**Bridge Wick.** As shown in figure 3, the bridge 111 spans across the wick 110. In some embodiments, the bridge gaps 12 are formed in the wick adjacent the top of the wick at or adjacent the connection between the bridge 111 and the perimeter wall of the wick. When there are gaps 12, the gaps do not extend all the way down to the bottom of the wick, but instead the wick is continuous in an area 13 below the gaps and below the location of the bridge connection to the perimeter wall of the wick. The gaps 12 create separated upper wick portion 10, 11. In some embodiments, there are no gaps 12 such as in wick 130 of Figure 2.

The bridge crosses from one side of the internal perimeter wall of the wick to an opposite side of the internal perimeter wall of the wick. In some embodiments, the bridge extends along a diameter of the wick passing through the geometric center of the hollow core wick before reaching the opposite side. In some embodiments, the bridge extends from one portion of the internal  
5 perimeter wall of the wick to another portion of the internal perimeter wall of the wick but does not pass through the geometric center of the wick.

The bridge 111, 113 bows or arches between the bridge attachment at opposite attachment points 14, 15 on opposite interior sides of the perimeter wall of the wick. The attachment points 14, 15, are located below the upper surface 132 of the wick. In some embodiments, the middle 16 of the  
10 bridge is located below the upper most edge of the upper surface 132 of the wick. In some embodiments, the middle 16 of the bridge is located level with the upper most edge of the upper surface 132 of the wick. In some embodiments, the middle 16 of the bridge is located above the upper most edge of the upper surface 132 of the wick. In some embodiments, the middle of the bridge is less than 0.5 inches above the upper most edge of upper surface 132 of the wick. In some  
15 embodiments, the middle of the bridge is less than 0.25 inches above the upper most edge of upper surface 132 of the wick. In some embodiments, the middle of the bridge is less than 0.25 inches above the top of the wick sheath 120. In some embodiments, the middle of the bridge is less than 0.1 inches above the top of the wick sheath 120. In some embodiments, the middle of the bridge between zero and 0.25 inches above the upper most edge of upper surface 132 of the wick.

20 When the bridge is ignited, the fuel and the flame will travel along the bridge and light the perimeter wall of the wick when the flame meets the perimeter wall of the wick at the attachment point 14, 15 of the bridge.

In some embodiments, the bridge has a width of 0.1 inch and a length of at least the diameter of the hollow core of the wick. To achieve an arch, the length of the bridge must be longer

than the diameter of the hollow core of the wick, when the bridge extends along the diameter. When the bridge does not extend along the diameter of the wick, it may have a length that is less than the diameter of the wick.

In some embodiments, the wick protrudes above the top of the wick sheath 120 by no more than 0.15 inches to maintain a smaller operating flame height of 1.0 inch from the wick to the top of the flame.

In some embodiments, the hollow core wick may begin as a flat wick, such as the wick 117 of figure 4. The wick 117 that is then curved so that the lateral edges 119, 121 are in contact or are adjacent to each other and a hollow core is formed in the center. A folding line or crease 133 may be provided delineating a first portion 123 and a second portion 125. The first portion 123 may be folded toward the second portion 125 in the direction A, the second portion 125 may be folded toward the first 132 in the direction B, or each portion 123, 125 may be folded toward the other so that lateral edges 119, 121 are joined or adjacent the other. The formed wick may be held in shape by the wick sheath 120 and the support ring 160.

The bridge 129 may be permanently attached to one of the portions 123, 125 and removably attached to the other. As shown in figure 4, one end of the bridge 129 has an arrow shape end 127, the bridge is arched in the direction C after or during the joining of the lateral edges 119, 121 and the arrow shape is pressed into a bridge hole/appature 137 in the opposite portion 125. The arrow shape deforms as it passes through the hole 137 and then regains its full shape after passing through the hole to prevent the bridge from withdrawn from the hole. The backs 127a, 127b of the arrow contact the outside surface of the wick in the second portion 125 adjacent the hole 137 so that the arrow head does not withdraw from the hole 137. In some embodiments, the wick has an inside diameter of about 0.5 inches, and preferably 0.555 inches, and a height of .4 inches.

In some embodiments, the portions 123, 125 are physically separated along 133. The adjacent edges at 133 can be located next to one another and the edges 119, 121 can be located next to each other to form the cylindrical hollow core and the wick can be held in shape by the wick sheath 120 and optionally the support ring 160.

5 In some embodiments, the wick perimeter is provided with two bridge holes, such as hole 137, each on opposite sides or different locations of the wick. The bridge is provided separate from the wick. The bridge has arrow head at both ends and each arrow head is inserted into one of the two bridge holes to removeably join the bridge to the wick. In some embodiments, the bridge has flat ends, instead of arrow head ends, and the flat ends are received in the corresponding bridge  
10 holes. The bridge holes may be any shaped aperture, including quadrilateral, circle, oval, slotted, and the like.

In some embodiments, the hollow core has multiple bridges, such as shown in figure 6A. Figure 6A shows the wick 110 with the first bridge 111 crossing over a second bridge 21 at a geometric center 110a of the wick 110. Figure 6A also shows a third bridge 19 that does not travel  
15 through the geometric center 110a of the wick and is offset from and non-crossing of the first bridge 111. In some embodiments, the third bridge 19 is parallel to the first bridge. It will be appreciated that in various embodiments, any variation of two, three, or more spaced apart side-by-side and/or crossing bridge may be used. In some embodiments, two spaced apart, non-crossing or crossing bridges may be provided so that none of the bridges pass through the geometric center of  
20 wick.

The bridge may comprise or be formed of any material which the wick perimeter is comprised of as disclosed herein. In some embodiments the bridge is formed of one type of material capable of acting as a wick and the wick perimeter is formed of another type of material capable of

acting as a wick. In some embodiments the bridge and the wick perimeter are formed of the same type of material.

Figure 22A and 22B show an alternative embodiment wick 406a similar to wick 400. In figure 22B the wick is shown flat, similar to wick 117 of figure 4. One or both of the opposite lateral edges 406f, 406g can be folded to the other/together to form a ring or cylinder. The wick can be held in shape by the wick sheath 120 and optionally the support ring 160. The end 406h of the bridge 406b can be inserted and retained in the bridge hole 406c to from the bridge as shown in figure 22A. The wick 406a has higher peaks 406d and closer peaks 406d and valleys 406e than the wick 400. This arrangement may be used in larger outdoor applications, such as a yard torch, a firepot, or a fire pit, where a larger flame is desired. The bridge may extend higher for such applications. In some embodiments, the center of the bridge is between 1/8 inch and 1 inch higher than the top of the peaks 406d. In some embodiments, the height from the bottom of the valleys 406e to the top of the peak 406d is 0.18 inch or more. Such a height allows liquid fuel inside of the burn chamber to escape, or overflow, through the area in the valleys 406e to outside of the wick system without extinguishing the flame on the wick at or about the peaks.

**Wickless Solid Fuel.** The burner system 100, 200 utilizes a solid fuel 201. The solid fuel may be of a configuration as disclosed in U.S. Patent Application No. 13/640,478 and U.S. Patent Application No. 13/868,966, which are herein incorporated by reference in their entirety to the extent not inconsistent with the present disclosure. The solid fuel can be in either a pellet form, such as shown in figure 36, or a pre-formed solid element, such as shown in figure 5.

The solid fuel used by the system may be comprised of solid wax fuels, such as soy wax, palm wax, beeswax, paraffin, or other hydrocarbon fuels that are solid below 90 degrees Fahrenheit(F) and liquid above 220F. More particularly, the solid fuel waxes used by the system may comprise those that melt when heated to temperatures in the ranges of 125F to 180F. The fuels

usable with the burner system include not only solid fuels but also liquid fuels. Therefore, the fuel used can be any meltable solid or liquid hydrocarbon or glycol whose flash point is in excess of 180F. Such fuels may include soy wax, palm wax, solid paraffin, liquid paraffin, olive oil, diethylene glycol, monoethylene glycol, among others.

5           A wickless solid fuel 280 is shown in figures 5-19. Referring to figure 7, the solid fuel comprises a priming section 202, a stoking section 204, and a main section 206. The different sections 202, 204, 206 of the solid fuel may be comprised of different fuel formulations, varying in a number of aspects including but not limited to melting point, vaporization point, oil content level, type of oil (fragrance, insect repellent, short chain hydrocarbons, medicinal ingredients, glycol, or  
10 other), and total mass.

In figure 7, the priming section 202 is configured to be positioned above at least a portion of the wick 110. In some embodiments, the priming section is in contact with the upper surface 141 of the wick 110. In some embodiments, the priming mass is adjacent but not directly above the wick 110.

15           In some embodiments, the priming section is in contact with a portion of the bridge 111, such as shown in figure 7. In some embodiments, the priming section is spaced apart and located above a portion of the bridge, such as shown in figure 8. In some embodiments, the priming section protrudes through the bridge gap 12. The priming section may be located above a portion of the wick not located at the bridge, such as shown in Figure 11.

20           When a portion of the priming section is located above the wick and / or the bridge, the portion of the wick or bridge below the overhanging priming section may be an ignition portion where the priming section will flow. This ignition portion is generally an upper portion of the wick or a portion of the bridge with a relatively small total mass to keep the total heat capacity at the point of ignition at a minimum. In this manner and as shown in the designs of wicks 130, 330, 340,

350, 360, 370, 390, 400 the ignition portions can be the peaks or raised portions along the wick. Likewise the raised portions of the wicks 410 and 420 may also be ignition portions. As a result, there can be multiple ignition portions about the top edge of the wick, any of which can receive the fuel from the priming section of the refill and be ignited.

5           The priming section is positioned so as to allow a typical igniting flame from a match or lighter to be in contact with the wick and to be close enough to melt at least a portion of the priming section. The priming section, once melted, preferentially flows toward and into the wick and/or bridge. The priming section, when melted, may fall directly on top of the wick and or bridge, and/or it may fall on to the side wall of the wick, and/or it may fall adjacent, but not directly on the wick,  
10 but then flow toward and make contact with the wick and or the bridge. The priming section has generally the smallest mass as compared to sections 204 and 206 because it, along with the wick, needs to be elevated to ignition temperature quickly by the flame. A larger mass will take longer to melt and provide fuel to the wick. Therefore the priming section enables an accelerated flame start time at the wick. The priming section is sized to balance, during ignition, between not enough fuel  
15 to ignite the wick and not too much melted fuel so as to avoid flooding the wick.

          The priming section may be initially melted by the ignition source, such as a match, lighter, a filament, or other flame source, before the flame begins on the wick. Once the flame begins on the wick and the ignition source is removed the flame on the wick will continue to melt the priming section. In some embodiments, the priming section, when melted by the ignition source, will flow  
20 directly to the portion of the wick that will first be ignited which is generally at or adjacent the placement of the ignition source.

          When the priming section is placed on or above the bridge, the priming section interfaces with the bridge by contact or by melting wax from priming section falling on the bridge to prime the bridge or a portion of the bridge, which is then easily and quickly ignited giving the bridges smaller

mass and surface area compared to the mass and surface area of the perimeter of the wick. The bridge then develops a flame that melts more wax to prime the totality of the wick 110 by flowing from the priming section to and along the bridge and to and on the outside perimeter of the wick adjacent the priming section. The flame transfers from the bridge to the perimeter of the wick and  
5 the flame is fully developed on and about the wick.

Igniting at the bridge results in a reduction in the time to prime and ignite a flame on the wick so that the flame is burning on the wick without further assistance of a starter flame, such as from a match or an external flame source. At least one test has shown an ignition time that is 7 to 15 second faster than if a bridge is not used on a hollow core wick. Ignition has been achieved in less  
10 than 8 seconds. Some tests show that a hollow core wick can take 15-24 seconds to light without a bridge but using a bridge on the same hollow core wick reduces the ignition time to 8 seconds or less.

Further, the use of a bridge for initial igniting maintained the reduction in priming and ignition time with consecutive ignitions and uses of the reusable hollow core wick. Some prior art  
15 techniques without a bridge show an increase in ignition times with repeated use. With one configuration of a hollow core wick with a bridge, ignition times averaged less than 7 seconds for 100 uses and whose range stayed consistently between 5 and 10 seconds throughout the 100 trials.

Another advantage of the bridge is a lower overall operating flame height of less than 1.25 inches with one embodiment of the hollow core wick with a bridge. In certain versions not having a  
20 bridge the operating flame heights were between 1.5 and 2.5 inches. Lower flame heights, while possible with previous wick designs, required excessive ignition times and provided difficulty in ignition times, particularly with repeated uses.

In some embodiments, the priming section has a mass in the range of 0.01 grams to 0.5 grams and hangs over the top of the wick in such a manner that when the fuel melts, the resulting

flow creates one or more drops of fuel that prime the wick. In some embodiments, the priming section has a mass of 0.5 grams or less.

The stoking section 204 is close enough to be melted primarily from heat radiation by the newly ignited flame at the wick and is generally of larger size than the priming section 202 because it  
5 needs to supply the fuel to wet the totality of the wick so that the full flame may develop. Unlike the priming mass, however, the stoking section needs to flow primarily away from the flame and toward the bottom portion of the wick otherwise the wick or flame may become flooded. Therefore the stoking section is positioned close enough to the flame to melt the fuel via radiating heat but far  
10 enough away to make sure the melting wax does not flow into the flame and flood the wick. A flooded wick would result in very slow flame development or may extinguish the flame. Flow channels, such as flow paths B and C of figure 19, may be provided to route melting wax so that it does not flood the flame

The melted stoking mass flows away from the ignited section of the wick and down toward the base of the wick system, entering the wick system 170 from the bottom, and wetting the wick  
15 from the bottom. This feeding of the wick from the bottom stokes the flame as it develops more fully. In this manner, the newly ignited flame is not at risk of flooding and will not starve itself of fuel since the melted fuel is delivered quickly to the wick system 170.

The function of the stoking section is to fully develop the flame and increase the system operating temperature above that of the melt point of the solid fuel. The stoking section must be of  
20 sufficient mass to allow the flame to burn until the system reaches the desired melting temperature. If not, the system will be starved of liquid fuel and the ignited flame will go out leaving a solid mass of wax fuel behind. The stoking section must also be designed in such a way as to avoid flooding the wick at or near the ignition area. This is done by creating a physical design of the stoking section and its placement relative to the wick system that allows the melted fuel of the stoking section to

flow to the wick either beneath the ignited portion of the wick or to the side of the ignited portion of the wick.

In some embodiments, the stoking section has a mass in the range of 0.25 grams to 2.5 grams. In some embodiments, the stoking section has a mass greater than 0.24 grams and less than 3 grams. In some embodiments, the stoking section has a mass that is 5 times the mass of the priming section. In some embodiments, the stoking section has a mass that is 25 times the mass of the priming section. In some embodiments, the stoking section has a mass that is in the range of 5 to 2500 times the size of the priming section.

The main section 206 is the largest of the three sections 202, 204, 206. The main section provides the bulk of the fuel that is melted primarily from conductive heat. Conductive heat is transferred from the flame through the wick sheath to the melting grate to the main section 206 in contact with the melting grate and within a radiating distance there from. Main section may also be heated through radiant heat transferred through ambient air from the flame at the wick. The main section provides a continuous supply of melted fuel to the base of the wick system to be drawn in and combusted in the burn chamber of the wick system 170 until the fuel in the lower fuel reservoir area 158 is exhausted. The main section is generally the furthest section from the flame and wick.

The main section has a mass that is sized depending on the desired total burn time of the system without a refill as well as the size of the melting grate 140 and/or the reservoir 150. In some embodiments, the main section has a mass in the range of 3 grams to 25 grams. In some embodiments, the main section has a mass in excess of 25 grams.

In some embodiments, the main section has a mass that is 10 times the mass of the stoking section. In some embodiments, the stoking section has a mass that is 12 times the mass of the stoking section. In some embodiments, the stoking section has a mass that is greater or equal to 10 times the size of the stoking section.

The solid fuel 280 may be configured, when placed adjacent other solid fuel as shown in figure 11, to form a completely surrounding fuel configuration about the wick system 170. Figure 11 shows one solid fuel missing so that the wick system 170 is visible.

When the solid fuel 280 is positioned adjacent the reusable wick, the nature of the geometry  
5 of the solid fuel will manage the igniting, forming, and maintaining the desired flame. Upon placing a match, lighter, or other igniting element close to the point where the solid fuel touches or is adjacent the wick, the heat from the ignition source melts the relatively small amount of wax that then flows toward and into the wick from the top of the wick system. When not igniting at the bridge, because the total mass of the priming section fuel combined with the wick is small relative to  
10 the mass of the full wick filled with fuel, the ignition flame then can elevate the collective mass of the of the full wick and melted fuel to its ignition temperature and the system is primed. When igniting at the bridge, because the total mass of the priming section fuel combined with the bridge is small relative to the mass of the full wick filled with fuel, the ignition flame then can elevate the collective mass of the of the full wick and melted fuel to its ignition temperature and the system is  
15 primed.

Once the wick is ignited, the flame then melts through the remainder of the priming section and into the stoking section 204 of the wickless refill through radiating heat from the flame though the ambient air. However, rather than drawing the newly melted fuel directly into the flame, this section of melting fuel runs away from the flame and toward the bottom end of the wick, seeking to  
20 fully replenish the wick with melted fuel without restricting or flooding the developing flame at the top. The spacing of the stoking section from the wick system 170 should be such as to allow space for the newly melted wax to flow so that it does not flow down onto the flame. The wax melting from the stoking section generally, during at least a portion of the melting of the stoking section, travels down the exterior of the wick sheath that itself is beginning to be heated by the flame above.

As the melted wax begins to fill or saturate the bottom of the wick, it enables the full development of the desired flame.

As the larger and more fully developed flame grows fed by fuel from the stoking section, the main section 206 begins to melt via conductive heating. The main section 206 is larger and  
5 comprises more mass than the stoking section or the priming section. The main section continues to supply/replenish the fuel within the wick from the bottom portion of the wick until the total mass of all fuel is exhausted and the flame is extinguished. When the flame runs out of fuel and is extinguished it will leave behind a dry wick ready to be used by another wickless wax refill.

Numerous geometries might be utilized to prime the wick by moving a relatively small  
10 amount of fuel to the point of ignition, to stoke the flame by moving more fuel away from the flame and toward the bottom of the wick, and to supply and replenish the reservoir 150.

Figure 10 shows that the upper portion of the solid fuel 280 has been melted. The upper portion will melt more quickly than the lower portion, as shown along sloped section 281a because the upper portion is in closer proximity to the flame during initial burning. Therefore the diagonal  
15 nature of the stoking section 204 as shown in figure 7 is due to the fact that the heat from the flame will melt the upper portion of the solid fuel earlier in the burning process.

Figures 12-19 show the solid fuel 280 in more detail. The solid fuel has a body 281, arms 282, 283, and a main protruding section 284. The body 281 has a back wall 285, an upper front wall 286, a lower front wall 287, a bottom wall 288, a left side wall 289, a right side wall 290. The back  
20 wall joins with the upper front wall, and the front wall joins with the bottom wall. The left and right side walls define the radial ends of the solid fuel. Each of the walls may meet a corresponding other at a curved joints as shown in figures 12-14.

The main protruding 284 has an upper protruding section 284j comprising a first forwardly extending portion 284a and a second forwardly extending portion 284b joining the first forwardly

extending portion 284a at a curved nose section 284i. The upper protruding section 284j has  
opposite inwardly converging sidewalls 284g, 284h. Below the upper protruding section 284j is a mid  
section having a first facing surface 284c. Below the mid section, is a lower section 284k having a  
first front wall 284d, and a first lower wall 284m. The first lower wall 284m extends from the body  
5 281. The first front wall 284d meets the first lower wall 284m at a curved intersection 284l. The  
lower section 284k has opposite side walls 284e, 284f. The main protruding section may be located  
at the midpoint between the side walls 289, 290.

The lower front wall 287 curves inward to create an open pool space 291 between the body  
adjacent and between the arms 282, 283. This pool space allows melting wax to gather between the  
10 body and the wick sheath to continue fueling the wick without flooding the wick. If open pool space  
291 forming a gap 219 between the bottom 287a of the lower front wall 287 did not exist, the wax  
may flood the wick and extinguish the flame.

The solid fuel 280 is formed so when the arms contact the wick sheath the upper protruding  
section 284j is properly positioned above the wick. Therefore, melted wax from the priming section,  
15 which includes the portion of curved nose section 284i that extends over the wick, can fall on the  
wick and initiate ignition of the wick. Further the arms ensure there this is sufficient space within the  
pool space 291 for wax from the stoking section to flow down the solid fuel and to the base of the  
wick sheath to fuel the wick from the bottom. In some embodiments, the gap 219 between bottom  
287a of the lower front wall 287 and the wick sheath is 0.125 inches at the bisecting vertical midline  
20 293.

Each of the arms are mirror image identical about the bisecting vertical midline 293.  
Therefore only arm 283 will be described. The arm has a rising bottom section 283a, which meets  
the upper portion 238b at a curved end 283c. As shown in figure 15, the curved end 283c does not  
extend substantially beyond the forward most portion of the upper front wall 286. In some

embodiments, the curved end 283c is co-planer with the forward most portion of the upper front wall 286. The arms rise above the lower most bottom 288 as the arms extend away from the body.

In some embodiments, the lower section 284k and/or the mid section having a first facing surface 284c are configured to contact the wick sheath, as shown in figure 7, when the upper protruding section 284j is properly positioned above the wick,. Therefore the lower section 284k and/or the mid section together with the arms create three points of contact between the solid fuel and the wick sheath that properly position the solid fuel and the priming section relative to the wick. Figure 19 shows a lower portion of the end of the solid fuel 280 with the arm 283 in contact with the wick sheath.

Figure 19 shows a number of flow paths along which melted wax may flow when heated by the heat generated from the flame on the wick system 170. A priming flow path A delivers melted fuel directly to the top of the wick or the bridge or both. The melted wax moving along priming flow path A will fall off of the upper protruding section 284j onto the top of the wick unit the upper protruding section 284j has melted to the extent that it no longer extends over the top of the wick or bridge or both. Stoking flow paths B and C deliver melted wax to the open pool space 291 where it will flow to the bottom of the wick sheath and be absorbed into the bottom of the wick.

In some embodiments, the wick sheath is not welded or sealed to the melting grate along its entire circumference and as the wax becomes more easily flowing through higher temperatures, some wax will flow between the melting grate and the bottom of the wick sheath and into the bottom of the wick without falling through the melting grate and into the reservoir. As the wax begins to melt, it may be slow flowing wax that will not immediately fall through the holes in the melting grate. Therefore wax will pool on the surface of the melting grate in the gap 219 during initial burning.

**Clog Resistance.** A system of method of resisting or preventing clogging of a reusable wick is disclosed. Figures 20 and 21 show the system 200 in various states of operation. In figure 15 the fuel level 304 of the liquid fuel 306 is risen above the melting grate 140 and above the bottom of the wick 130. The wick is at least partially submerged in the liquid fuel.

5 Figure 21 shows the system 200 where the liquid fuel 316 has a fuel level 314 that is below the melting grate 140 and below the bottom of the wick 130. There is an air gap 318 between the fuel level 314 and the melting grate and wick.

Certain advantages are achieved when the liquid fuel level 314 is not in direct contact with the wick. When the fuel level 314 is not in direct contact with the wick 130, air 317 is drawn through  
10 the melting grate and into the bottom of the burn chamber 172 of the wick system 170. The gap 318 can be macroscopic in scale or microscopic, as long as it creates a situation where the bottom most portion of the wick material is no longer in direct contact with the fuel housed in the fuel reservoir 150 and there is a path for air to be drawn into the burn chamber from the lower opening of the wick system 170.

15 The gap 318 provides for an arrangement that resists or eliminates wick fouling or clogging for at least two reasons. First, throughout the operation of the system 200, since the bottom most portion of the wick is not in contact with the lowest portion of the fuel reservoir, any solids or particles that are suspended in the fuel will precipitate or fall to the bottom of the fuel reservoir and will not enter the wick material.

20 Second, when the fuel level sits above the melting grate, covering the bottom portion of the burner assembly and delivering fuel to the flame directly through the wick material as shown in figure 20, the flame 300 is sustained. However, when the fuel level is maintained below or drops beneath the grating or false bottom, the heat created by the system 200 continues to vaporize the

fuel near but not in direct contact with the bottom of the burn chamber. The vaporization will occur at or adjacent the surface 314 of the liquid fuel.

As a gap is created or maintained between the bottom of the wick and the top of the fuel level 316, air begins to be drawn into the burn chamber through the bottom of the burn chamber 5 172. The drawn air picks up the vaporized or gas phase fuel as it proceeds into the burn chamber and/or onto the wick and the vaporized or the vapor phase paraffin is combusted. Generally wax fuels vaporize at temperatures between 390F and 420F depending on the type of wax. With the addition of more air into the burn chamber, the resulting fire/flame 310 burns hotter, creates more thermal energy that vaporizes more fuel, then the flame of the system operating as shown in figure 10 20 with the wick submerged in the liquid fuel. As the gap widens, toward the end or exhaustion of the fuel supply in the reservoir 150, more air will be drawn into the burn chamber and with the air more vaporized fuel, which will cause the flame to burn hotter. The flame will stop if the gap becomes too great to allow fuel to be vaporized and drawn into the chamber or if that does not first occur, then when the fuel is completely or consumed. The distance after which the gap between the 15 wick and the liquid fuel is too great to fuel the fame depends on the scale of the overall system. In one embodiment, a gap distance of greater than 3/8 of an inch was found to be too great to continue fueling the wick. However, in larger scale systems, fueling may continue even after a 3/8 inch gap is achieved. As a result of the increase burn temperature during the end of the fuel supply, the system provides for a self-cleaning cycle where the wick eliminates or avoids particulate build up 20 during the hotter operating temperatures at the end of fuel consumption. The self-cleaning cycle begins when the liquid level of fuel drops below the bottom of the wick and continues until no more fuel can be vaporized from the surface of the melt pool from the radiation of the flame.

Therefore the gap allows vaporized fuel to be drawn into the burn chamber premixed with oxygen which creates a hotter flame 310, as shown in figure 21, as compared to the steady state flame 300 that draws its fuel into the wick base as a melted liquid, such as shown in figure 20.

Once the cleaning cycle temperature threshold is met and/or exceeded, any solids that might have clogged the wick are retained in the bottom of the fuel reservoir and any accumulated varnish, tar, carbon deposits, or other elements are consumed, volatilized, or otherwise released from the wick material as the burn chamber begins to operate at the elevated cleaning temperature. The result is an assembly resistant to the clogging or fouling than is generally seen and expected as longer chain hydrocarbon fuels like waxes or paraffin are burned.

The system provides less soot or unwanted byproducts of combustion delivered to the air because the chemical ingredients prone to incomplete combustion are either retained in the unused portion of the fuel or combusted at a higher temperature.

The gap between the bottom of the wick system and the bottom of the fuel reservoir 150 creates a thermal buffer that allows the reservoir basin or bowl to be made of materials that are otherwise prone to thermal shock or degradation.

In one embodiment, the reservoir 150 is concave in shape with a nine inch diameter and two inch height. The reservoir 150 is comprised of transparent or translucent etched glass that allows the light of the flame 310 to shine through the fuel and down to offer down lighting to the area under the reservoir. The melting grate is a flat perforated aluminum sheet of 4.25 inch diameter. This creates a distance between the melting grate and the bottom of the reservoir 150 of about 0.5 inches at the center 151 of the reservoir 150. The wick sheath has a diameter of 1.5 inch and a height of 1.1 inch and is formed by cutting aluminum tubing cut at 1.1 inch increments. The wick has a height of 1.3 and comprises Fiberfrax® 550F ceramic paper with a wavy pattern cut at the top to facilitate ignition. The solid fuel may be IGI 1239 granulated paraffin. In this embodiment, when

the system reaches its end of use, the remaining fuel in the reservoir is about 0.2 inches deep at the center 151 and the entire surface of the wick, including the upper portion of the wick supporting the flame, is relatively clean of carbon deposits and is one that can easily be relit and used repeatedly.

In some embodiments, the gap between the bottom of the wick and the lower most point of the fuel reservoir 150 at the center 151 can be as small as the thickness of the melting grate. In such an arrangement the melting grate is spaced closely to the bottom of the reservoir 150. In some embodiments, the wick may comprise any kind of non-consumable material or refractory product. In some embodiments, the wick system diameter can range from 0.25 inches to in excess of 3 inches in diameter, the wick and support ring being sized correspondingly. In some embodiments, burn devices using this method can use one or a plurality of wick systems placed upon the grate to create a customized flame effect. The customized flame effect can comprise a flame pattern that spells out a message in words or letters. The customized flame effect can comprise a flame pattern emulates a flame fountain with some parts of the flame being taller than others. The flame fountain effect can be achieved by forming some wick systems that burner taller than other wick systems on the melting grate.

**Wicks and Wick Sheaths.** Figure 22C provides a top view of the wick 130. Figures 22C-22G show alternative embodiment wicks and wick sheaths. Figure 22D shows a wick 340 and a wick sheath 348 that are each rectangle. The top surface of the wick has peaks 342 and valleys 344 between the peaks. A burn chamber 346 is located within the wick. In other embodiments, the wick and wick sheath may comprise other quadrilateral shapes, such as a square or a trapezoid.

Figure 22E shows a top view of a wick 350 and wick sheath 358 having a spiral configuration 355. The spiral configuration has an open side entrance 351. The sheath 358 has an end wall 359 at the internal end of the spiral. In this spiral configuration the inner surface of the wick faces an outside surface of the wick sheath along a portion thereof. In the center 353 of the

spiral configuration a portion of the wick faces another portion of the wick rather than the wick sheath. A burn chamber 346, 347 is located within the spiral configuration 355 between the beginning 358a and end wall 359 of the wick sheath and/or wick. The top surface of the wick has peaks 352 and valleys 354 between the peaks.

5           Figure 22F shows a top view of a wick 360, 361 and wick sheath 368, 369 having a straight spaced-apart configuration 365. The straight spaced apart configuration may be a parallel configuration. The wick sheath 368, 389 is provided in two spaced apart portions and the wick is provided in two spaced apart portions 360, 361. The configuration provides for opposite open ends 366a, 366b adjacent ends of the wick and wick sheath. A burn chamber 366 is provided in the space  
10 between the interior surfaces of each wick portion 360, 361. The top surface of the wick has peaks 362 and valleys 364 between the peaks.

          Figure 22G shows a top view of a wick 370, 371 and wick sheath 378, 379 having a curved spaced-apart configuration 375. The wick sheath 378, 379 is provided in two spaced apart portions and the wick is provided in two spaced apart portions 360, 361. The configuration provides for  
15 opposite open ends 366a, 366b adjacent ends of the wick and wick sheath. A burn chamber 376 is provided in the space between the interior surfaces of each wick portion 360,361. The outer ends of each of the opposite wick and wick sheath portions are closer to each other along the longitudinal length than at the center 376c. The top surface of the wick has peaks 372 and valleys 374 between the peaks. The configurations shown in figures 18-22 can be used in the burner systems 100, 200  
20 described herein.

          Figures 23 through 28 show alternative embodiments of top edge arrangements for wicks from a side view. Figure 23 shows a wick 380 with a flat top edge 382.

          Figure 24 shows a wick 390 having a wavy top edge 396. The wavy top edge has pointed or substantially pointed peaks 392 and curved valleys 394 between the peaks.

Figure 25 shows a wick 400 with a jagged top edge 406. The top edge 406 has pointed or substantially pointed peaks 402 and pointed or substantially pointed valleys 394 between the peaks where the walls of the valleys or peaks are straight or substantially straight.

Figure 26 shows a wick 410 with a notched top edge 416. The top edge 416 has plateaus 412 and valleys 414 between the plateaus. The plateaus and valleys are flat. The side walls between the plateaus and the valleys may be perpendicular to the plateaus and the valleys.

Figure 27 shows a wick 420 with a curvy top edge 416. The top edge 426 has peaks 422 and valleys 424 between the peaks. The peaks and the valleys are curved. In some embodiments, the curvy top edge resembles a sine wave.

10 A bridge may be provided across the burn chambers of any of the wick of figures 22C-22G, such as shown with bridges 341, 355a, 361a, 375a.

In some embodiments, the wave pattern will create an uneven flame base creating the appearance of four flames combining into one as the flame proceeds upward from the wick. This effect may also be created with the wick shapes of at least figures 24, 25, 26, 27, and 28 as well as  
15 other raised portion of the top of various wicks disclosed herein.

Figure 28 shows a wick 430 with an angled top edge 422. The top edge 422 has a first side 426 that is shorter than an opposite second side 424.

Each of the top edge configurations shown on wicks 380, 390, 400, 410, 420, 430, can be used any in place of wicks 110, 130, while retaining the bridge 111, 113. In other words, the wick  
20 110, 130, can be modified to include a top edge shown for any of wicks 380, 390, 400, 410, 420, 430. The bridge may extend from one portion of the wick and be connectable to an opposite side, or the bridge may be removably attachable to each opposite side of the wick, as described above, or may be formed connected to each side. Further, a wick may use more than one top edge configuration on the same wick. For example, a wick may comprise a portion of the top edge having the jagged top

edge 406 configuration and another portion of the top edge having the wave top edge 416 configuration.

The wick system uses the wick sheath to provide the boundary of the burn chamber. Within that burn chamber is wick material that only partially fills the space within the wick sheath. The wick material extends above the wick sheath to facilitate ignition and to create the top flame beneath which the vapor phase fuel is housed or staged.

The inside of the burn chamber comprises at least 10% open space. In some embodiments, the inside of the burn chamber comprises more than 50% open space. The wick material can line the inside of the wick sheath or stand apart from the wick sheath but generally has at least one surface open to the burn chamber through which surface vapor phase fuel can be delivered to the burn chamber.

A lower portion of the wick exposed to liquid or vapor fuel delivers vapor phase fuel to the burn chamber while the uppermost portion of the wick maintains the fire near the top of the burn chamber. In this way, there is always an excess of fuel ready to burn.

The combustion stoichiometry is moderated and manipulated by the access to oxygen. In the wick system, this is done generally at least in one of at least two ways. One method is to perforate the side walls, such as with the holes 124, of the wick sheath to allow air to enter into the burn chamber through the wick or directly into the burn chamber. Another method to allow oxygen into the burn chamber is around the wick surface at the top of the burn chamber. This is accomplished by creating an uneven surface upon the top of the wick, such as those shown in figures 24-28. In this method, air enters from beneath or within the physical structure of the flame.

**Electric Ignition.** Figure 22, 29-25 show an electric ignition system comprising a first post 502, a second post 504, a filament 506, and an electronic igniter circuit 508. Figure 29 shows a wick 105 that is identical to wick 110, but that does not have a bridge. The filament is connected to each

post at or adjacent the top end of each post so that the filament spans between each post and connects at opposite ends the posts. As shown in figure 32, an upper portion of the post may be bent toward the inside perimeter wall of the wick 105 so that the filament is placed on or adjacent in close proximity to a portion of the perimeter wall of the wick 105. The filament may be placed so  
5 that it is directly under a portion of the priming section 202 of the solid fuel 280. In other arrangements the filament may not be directly under the priming section 202, but may be adjacent the area under the priming section so that radiant heat from the filament will cause the priming section to melt and fall onto a portion of the wick adjacent the filament. The filament can be placed in any position close to the wick and adjacent a fuel source.

10 Figure 29A, shows another embodiment of the fuel burner system 100, where a base 534 is provided about the melting plate 134. The base houses two buttons/switches 538, 540. The base may contain an alternate embodiment fuel reservoir 535 that is shallow and located under the melting grate 140. As shown in figure 34, the bottom of the melting grate 140 be closely spaced to the reservoir 535, so that only a small gap 537 exists between the reservoir and the melting grate.

15 Figure 30 shows wick 110 with the bridge 111. Each of posts 502, 504 are located on opposite sides of the bridge from the other post. The filament 506 extends under the bridge between the posts. The filament may be in contact with the bottom surface of the bridge or may be spaced apart from the bottom surface of the bridge. The filament may be placed so that it is directly under a portion of the priming section 202 of the solid fuel 280 as shown in figure 31. In other  
20 arrangements the filament may not be directly under the priming section 202, but may be adjacent the area under the priming section so that radiant heat from the filament will cause the priming section to melt and fall onto the bridge and/or a portion of the wick adjacent the filament, such as shown in figure 33. The filament may be placed next to a peak, such as peak, peaks 392, or other raised areas of the wick perimeter, such as areas 392, 412, 422, 424.

Figure 34 shows an enlarged view of the support structure for the posts. Each post has a post dip pin 510, 512 and a bottom post portion 514, 516 extending below the post dip pin. Each of the post dip pins 510, 512 is configured to be received in support dip pin receivers 518, 520 in a reservoir 535 of a base 534 located below the melting grate 140. The post dip pins 510, 512 are shown diagrammatically and may be shaped to in the same manner as the support dip pin receivers so that the post dip pins are secured in the support dip pin receivers by friction fit. The pin receivers are secured in holes 522, 524 with a seal or sealant 526, 528, such a silicon, high temperature epoxy, a rubber seal, or other seal or sealant capable of preventing oil, melted wax, or other liquid from passing through the holes 522, 524. The base 534 may be fixed to the bottom of the melting grate.

Wires 530, 532 connect to each of the support dip pin receivers 518, 520 to transfer power from the circuit 508. In some embodiments, the support dip pin receivers are mounted directly to the support grate at the holes 142 and a base 534 is not used. The posts are conductive or contain a conductive element to transfer the power from the circuit 508 to the filament.

Figure 35 shows one embodiment of the electronic igniter circuit 508. The circuit has a power supply, such as provided by batteries (not shown). The circuit comprises a timer 536, two switches 538, 540, among other components as shown in figure 35. The filament is energized (1) as long as switch 538 is depressed or (2) for a predetermined amount of time, such as 45 seconds, if both the switch 538 and switch 540 are depressed simultaneously and then released. The power supplied to the filament 506 causes the filament to emit heat. In some embodiments, the circuit does not have a timer, but instead the filament is energized as long as the switches are held down. In some embodiments, the filament is always operated on a timer regardless of the how the switches are pressed. In some embodiment, only one switch is provided.

The heated filament causes the ignition of solid fuel burner system 100, 200. It accomplishes this by the filament being close to both the wax and the wick and or bridge. Close enough to result

in radiation heating to both the wick/bridge and the solid wax. Upon energizing the filament, it glows and causes the radiant heat melting of the wax. The wax then flows preferentially to the perimeter of the wick, which may include a peak or raised area and/or to the bridge, which provides an ignition area. The ignition area is smaller in total size and mass and therefore has less total heat capacity than the ultimate or full wick. The heat of the filament that at first melts the wax then also heats the wick/bridge (now containing liquid wax) to its ignition temperature. In some embodiments the ignition temperature is a temperature above 375 degrees Fahrenheit. At this point the filament can be de-energized. The ignition area is positioned in such a manner relative to the melting wax as to not be prone to flooding by the continuing wax melt flow. The flame, and the filament when energized, continue to melt additional wax that will flow to the wick and enable the development of the full flame upon the full wick. That flow to the wick can be in any number of ways as long as it preferentially does not flow directly toward the initial or developing flame. The flame then continues to stay lit until substantially all of the wax is consumed by the flame.

In some embodiments, the energized filament is placed within the burn chamber or generally surrounded by the wick system 170 such that, once the ignition wick is lit and the full flame develops and as the system increases in temperature, the ignition filament is in an oxygen starved environment within the burn chamber, which protects the filament from oxidation and prolongs its useful life. The flame is located above the filament so that the filament is not directly within the flame of the wick. This location hides or partially hides the filament from external view. It also protects the filament from the high temperature at the flame burning slightly above the wick. The filament can be located level with the top of the wick or below the top of the wick and can therefore avoid the harmful effect of direct heat within the flame.

In some embodiments, the filament 506 comprises tungsten having a 0.0002 inch thickness. The filament has 10 looping turns with each loop having a 0.02 inch diameter. The electric ignition

system matches the voltage delivered by the electronic igniter circuit 508 to the filament design such that the filament glows sustainably when energized with the circuit voltage.

As is shown in the figures, the filament 506 of the ignition system is placed with an upward bias toward the uppermost portion of the wick 105. When positioned in that manner, the glowing filament is in a position to cause the melting of a first portion, such as the priming portion, of a solid fuel 280 from radiation heating. That priming portion of melting wax flows preferentially or directly toward the portion of the wick close to the glowing filament, thereby priming the wick. The glowing filament then heats this primed area of the wick to the ignition temperature resulting in the first flame upon the wick. The flame then melts the next section of the solid wax refill that flows generally toward the wick assembly but not directly toward the first ignited flame. In this example, the secondary melt flows beneath the uppermost portion of the wick sheath and to the wick either through the air intake apertures or holes 124 near the top of the wick sheath or to the wick at the bottom of the wick assembly.

In some embodiments, pourable wax granules 542 as shown in figure 35, having a diameter of less than 0.25 inches, are used as a fuel source. In order to do this, the burn chamber must manage the granules as they are poured upon and into the assembly. The natural flow of poured granules leaves the filament in a position to melt sufficient wax, prime the wick, and ultimately ignite that portion of the wick close to the filament. Such granules can also be provided outside of the burn chamber on the melting grate adjacent the wick and wick sheath.

Figures 22D-22G show the ignition system deployed on various shaped wicks where the filament 506 is located adjacent to an interior wall portion of the corresponding wick.

Figures 37-41 shows the ignition system deployed on further alternative embodiment wick shapes. Figure 37 shows wick 550 having a curved path configuration. The wick comprises a first concave wick portion 552 and a second concave wick portion 554 spaced from portion 552.

Portions 552 and 554 have the same curvature and are oriented in the same manner so a curved path is formed between the portions. The filament is centered along the curved path between the portions 552, 544.

Figure 38 shows a top view of a wick 560 having a straight spaced-apart configuration similar to the wick of figure 22F. In figure 38, the filament is centered between wick portions 562, 564.

Figure 39 shows a top view of wick 570 having a s-curve configuration. The first wick portion 572 has a s-shape and the second wick portion 574 has an s-shape. The first and second wick portions form an s-shaped channel between the portions. The filament 506 is centered in the s-shaped channel.

Figure 40 shows a top view of wick 580 having a parallelogram configuration. A first side of the wick has a long portion 581, an angled portion 583, and a short portion 585. The second side of the wick has a long portion 582, an angled portion 584, and a short portion 586. Portions 581 and 586 form a first channel into the parallelogram center 587 of the wick. Portions 582 and 585 form a second channel into the parallelogram center. The first channel is opposite the second channel.

Figure 41 shows a top view of wick 590. The wick comprises a semi-enclosed curved section 592, and opening 594, and an s-shaped section 596 outside of the curved section. The filament 506 is located within the semi-enclosed section and adjacent to an interior wall of the semi-enclosed section.

Figure 42 shows another embodiment where a hollow starter wick 600 is provided within wick 104. The hollow starter wick is the same as wick 130 except it is sized smaller to fit within wick 104. The starter wick 600 is located adjacent to a side 103 of the wick 104. The filament 506 is located within the wick 600 and adjacent to a perimeter wall of the wick 600. The flame will ignite

on the starter wick and the flame will transfer from the starter wick by its close proximity to the side 103 of the wick 104 and then proceed to fully light the wick 104.

Figure 43 shows a partial view of another embodiment where a starter wick 602 is in close proximity or in contact with the side wall of wick 102. Wick 102 is identical to wick 130, except wick 5 102 does not have the bridge 113. The filament is in contact or in close proximity to the starter wick 602. The flame will start on the starter wick 602 and transfer the flame to the wick 130 where the full flame will develop on wick 102. The starter wick extends down to the melting grate within the burn chamber and is supported by the melting grate.

In some embodiments, the buttons communicate with the electronic igniter circuit 508 by 10 wireless communication. The buttons 538, 540 are provided on a remote control that has a wireless transmitter or transceiver and the electronic igniter circuit 508 has a wireless receiver or transceiver for receiving communications from the buttons.

In some embodiments, the buttons 538, 540 are connected through wired or wireless communication to multiple electronic igniter circuits 508 and thereby multiple filaments to control 15 the ignition of multiple solid fuel burner systems. In some embodiments the electronic igniter circuit 508 requires an access code, password, fingerprint scan, or other authentication action to authenticate a user before the filament is powered. This prevents the circuit from inadvertent activation or activation by an unauthorized user, such as a child. The access code or other authentication may be provided by a user at the buttons 538, 540 or by another user input device, such as a keypad, user's 20 phone, tablet, or computer operatively connected to the electronic igniter circuit.

In some embodiments, alternative filaments and ignition circuits can be used to operate the electric ignition system at alternative voltages, such as at 12 to 15 volts DC for outdoor landscape applications. In some embodiments, the filament comprises nichrome, tungsten, or other known materials usable as a heating filament.

In some embodiments, the filament is a different shape, such as a straight hot wire, single helix cylindrical, double helix cylindrical, planar and spiral, toroidal, or a combination thereof.

The advantages of this invention are many and some of which are provided below. The low ignition mass, particularly at the bridge and at the peaks of the wick, both fuel and wick material, allow for both ease of ignition and faster flame development. The open geometry of the burning surface creates a larger flame without the expected increase in soot production. This larger flame, then, can be used to create much faster heat delivery to the system to melt additional solid fuel, to deliver a volatile ingredient to the air more quickly, and to create a higher operating temperature that can deliver a volatile ingredient more completely to the environment. This system works especially well if coupled with a thermally conductive base (a melting plate) or a heat conductive grate. By staging the fuel in its vapor phase (ready to burn) and limiting the access to oxygen, this invention balances the combustion stoichiometry to reduce soot production and even eliminate it at the smaller scales. The staging of the vapor phase fuel within the burner assembly creates a wind resistance when the covering flame is disrupted by the wind or a breeze. The systems of the invention having a wick and or wick sheath with a diameter of 2 inches or greater have withstood 30-40 mile per hour winds without the flame being extinguished.

In some embodiments, the wick is non-consumable and has a thickness of about 1/16 inch. The wick sits against the inner wall of the wick sheath and thereby creates the burn chamber within the exposed center, lined by the wick. The wick sheath is perforated aluminum with 0.0625 inch holes near the top of the wick sheath. The wick top is patterned to offer a natural ignition point. The height of the wick sheath is about 50-66% of the wick sheath diameter. The wick may be composed of FiberFrax® ceramic paper. In this embodiment, the burner system scales well from indoor candle to table-top burner to yard torch to fire pit.

The burning system can be refined or modified to accommodate a large variety of usage applications. The overall vertical height of the system can be extended vertically to showcase the flame or create a more vertical system, such as disclosed in figure 2 of U.S. Patent Application No. 13/640,482. A system with an extended vertical height may be suitable for outdoor applications  
5 where previously yard torches, such as TIKI torches, have been used. In some embodiments, the wick materials used can be of several natures and types including but not limited to ceramic, fiberglass, porous rock, porous metal, or any other kind of refractory product like papers, felts, blankets, tissues, and mats. The thickness of the wick may be of any thickness suitable to the desired application. The burner chamber geometries can be widely varied including but not limited  
10 to cylindrical, quadrilateral, box, oval, spiral, paired linear, bracketed, among others. The wick system can be paired with a melting plate or a melting grate, such as melting grate 140 to facilitate heat transfer. The wick system can be used with a solid fuel (blocked, carved, shaved, pelleted, or granular), such as fuel 280, or a lower volatile liquid fuel (like olive oil), or a fuel formulated with a volatile active ingredient including but not limited to fragrance, insect repellent, medicinal active, or  
15 other ingredient. The wick material or mass can be continuous, non-continuous, or perforated. The non-continuous or perforated wicks allow additional heat transfer through the wick.

From the foregoing, it will be observed that numerous variations and modifications may be effected without departing from the spirit and scope of the invention. It is to be understood that no limitation with respect to the specific apparatus illustrated herein is intended or should be inferred.

The invention claimed is:

1. A wax burning system comprising:

a melted wax reservoir;

a melting grate configured to receive a solid wax, the melting grate located above at least a portion of the melted wax reservoir so that wax melted on the melting grate can be received into the melted wax reservoir;

a wick comprising a perimeter wall, a hollow core, a bridge, and an upper exit opening in communication with the hollow core, the bridge has a first end and a second end, the first end joins with a first portion of the perimeter wall, the second end joins with a second portion of the perimeter wall, the bridge extends across the hollow core between the first and second portion of the perimeter wall, the hollow core forms a burn chamber extending above the melting grate;

the hollow core is sized to stage vapor phase fuel below the flame adjacent the upper exit opening to create a partially oxygen deprived condition at a flame on the wick.

2. The system of claim 1, wherein the bridge pass through the geometric center of the hollow core.

3. The system of claim 1, wherein the bridge is located adjacent to the upper exit opening.

4. The system of claim 1, wherein the bridge comprises a middle between the first end and second end, the bridge arches upward from the first end to the middle and the bridge arches upward from the second end to the middle.

5. The system of claim 1, wherein the perimeter wall has a top edge, and the bridge is located at or below the top edge.
6. The system of claim 1, wherein the perimeter wall has a top edge, and the bridge comprises a middle between the first end and second end, the middle is located above the top edge of the perimeter wall and the first and second ends are located below the top edge of the perimeter wall.
7. The system of claim 6, wherein the middle of the bridge is not more than 0.25 inch above the top edge of the perimeter wall.
8. The system of claim 1, wherein the first portion of the perimeter wall is directly opposite of the second portion of the perimeter wall.
9. The system of claim 1, wherein at least one of the first or second ends is integrally formed with the perimeter wall.
10. The system of claim 1, wherein the first or second portion comprises a bridge receiver aperture, and the corresponding first or second end of the bridge is joined to the perimeter wall at the bridge receiver aperture.
11. The system of claim 1, wherein the first or second portion comprises a bridge receiver aperture, and the corresponding first or second end of the bridge is removably joined to the perimeter wall at the bridge receiver aperture.

12. The system of claim 1, wherein the first or second portion comprises a bridge receiver aperture, and the corresponding first or second end of the bridge is has a stop that prevents the corresponding end from removal from the bridge receiver aperture.
13. The system of claim 1, wherein the first and second portion each comprises a bridge receiver aperture, and the corresponding first and second ends of the bridge are joined to the perimeter wall at the corresponding bridge receiver apertures.
14. The system of claim 1, wherein the wick comprises a shape selected from the group consisting of a circle and an ellipse.
15. The system of claim 1, wherein the wick comprises a shape selected from the group consisting of a quadrilateral, a rectangle, and a spiral.
16. The system of claim 1, wherein the perimeter wall comprises a first perimeter wall and a second perimeter wall, the first perimeter wall comprising the first portion, the second perimeter wall comprises the second portion, the bridge extends from the first perimeter wall to the second perimeter wall through the hollow core.
17. The system of claim 1, wherein the bridge comprises the same material as the perimeter wall.
18. The system of claim 1, wherein the bridge comprises a different material than the perimeter wall.

19. The system of claim 1, wherein the bridge comprises a material selected from the group consisting of: ceramic fiber paper, sintered glass, porous metals, porous ceramics, porous rock, metal weave, fiberglass, fiber glass cloth, refractory paper, refractory felt, refractory foam, refractory roll board, refractory tissue, carbon fiber woven cloth, and carbon composite.
20. The system of claim 1, wherein the perimeter wall has a top edge comprising a plurality of raised portions and a plurality of lowered portions.
21. The system of claim 1, wherein an outside of perimeter wall is surrounded by a wick sheath and the inside of the perimeter wall is adjacent a support ring.
22. A method of operating a wax burning system, comprising the steps of:
- locating a solid fuel on a melting grate adjacent to a wick, the solid fuel having a priming section, the wick comprising a perimeter wall, a hollow core, a bridge, and an upper exit opening in communication with the hollow core, the bridge extends across the hollow core between a first portion and a second portion of the perimeter wall;
  - positioning the priming section adjacent to the bridge;
  - heating at least a portion of the priming section with an ignition source so that a portion of the priming section melts and falls onto the bridge;
  - igniting the bridge when the bridge comprises a sufficient amount of fuel to support a flame; and

transferring the flame from the bridge to the perimeter wall of the wick.

23. The method of claim 22, wherein the step of igniting the bridge comprises the step of igniting the bridge with the ignition source.
24. The method of claim 23, comprising, after the step of igniting, the step of melting, with the heat from the flame on the wick, the remaining priming section to fuel the flame on the wick.
25. The method of claim 24, comprising, after the step of igniting, the steps of melting, with the heat from the flame on the wick, a stoking section of the solid fuel and drawing the melted fuel into the wick from a lower portion of the wick to fuel the flame on an upper portion of the wick.
26. The method of claim 24, comprising, after the step of igniting, the steps of melting, with the heat from the flame on the wick, a main section of the solid fuel by transferring heat to the main section through the melting grate and drawing the melted fuel into the wick to fuel the flame.
27. The method of claim 22, wherein the step of heating comprises the step of heating at least a portion of the priming section with an ignition source so that a portion of the priming section melts and falls onto the bridge adjacent the perimeter wall of the wick.

28. The method of claim 22, wherein the step of heating comprises the step of heating at least a portion of the priming section with an ignition source so that a portion of the priming section melts and falls directly on a top surface of the perimeter wall and the bridge.
29. The method of claim 22, wherein the step of heating comprises the step of heating the priming section with an ignition source so that a portion of the priming section melts and falls onto the wick without flooding the wick.
30. The method of claim 22, wherein the step of positioning comprises the step of placing a base of solid fuel on the melting grate so that the priming section of the solid fuel extends over at least a portion of the perimeter wall and the bridge.
31. The method of claim 22, comprising the steps of:
- melting the solid fuel with a flame burning on the wick;
  - collecting the melted fuel in a reservoir below the wick;
  - maintaining a level of the melted fuel in the reservoir below the bottom surface of the wick;
  - converting liquid fuel in the fuel reservoir into gaseous fuel with heat from the flame;
  - and,
  - fueling the wick by drawing gaseous fuel into the wick.
32. The method of claim 22, wherein the step of fueling comprises the step of drawing the gaseous fuel into a burn chamber formed by the wick.

33. The method of claim 22, wherein the step of fueling comprises the steps of  
drawing air through a melting grate toward the reservoir;  
drawing the air adjacent a pool of melted fuel in the reservoir to pickup gaseous fuel; and  
drawing the air and gaseous fuel into the burn chamber to fuel the flame.
34. The method of claim 22, wherein the step of fueling comprises the steps of  
drawing air through a melting grate toward the reservoir, the wick supported by the  
melting grate above the reservoir;  
drawing the air adjacent a pool of melted fuel in the reservoir to pickup gaseous fuel; and  
drawing the air and gaseous fuel into a hollow burn chamber, formed by the wick, to fuel  
the flame.
35. A wax burning system comprising:  
a melted wax reservoir;  
a melting grate configured to receive a solid wax, the melting grate located above at least  
a portion of the melted wax reservoir so that wax melted on the melting grate can be  
received into the melted wax reservoir;  
a wick comprising a hollow core, and an upper exit opening in communication with the  
hollow core, the hollow core forms a burn chamber extending above the melting  
grate;  
an electronic ignition system, comprising a power source, a filament, and a filament  
support, the filament is attached to the filament support, the filament support  
positions the filament adjacent the wick, the filament is configured to receive power  
from the power source and to generate heat.

36. The system of claim 35, the filament and filament support are located within the hollow core of the wick.
37. The system of claim 35, wherein the electronic ignition system comprises an electronic circuit; the power source and the filament are connected to the electronic circuit; the electronic circuit configured to direct power from the power source to the filament, to generate heat at the filament.
38. The system of claim 37, wherein the electronic ignition system comprises a switch, the switch is connected to the electronic circuit, the electronic circuit is configured to direct power from the power source to the filament, to generate heat at the filament, when the switch is activated.
39. The system of claim 38, wherein the electronic ignition system comprises a timer and the electronic ignition system is configured to direct power to the filament for a predetermined amount of time after the switch is activated.
40. The system of claim 35, wherein the electronic ignition system is configured to direct power from the power source to the filament to generate heat at the filament above 375 degrees Fahrenheit.
41. The system of claim 35, wherein the filament support comprises two filament supports and the filament extends between the two filament supports within the hollow core of the wick.

42. The system of claim 35, wherein the filament comprises tungsten.
43. The system of claim 35, wherein the filament support is supported at or below the melting grate.
44. The system of claim 35, comprising a solid wax positioned on the melting grate so that a priming portion of the solid wax is positioned adjacent the filament.
45. The system of claim 35, comprising a solid wax positioned on the melting grate so that a priming portion of the solid wax is positioned above the filament.
46. The system of claim 35, wherein the wick comprises a perimeter wall and a bridge, the bridge has a first end and a second end, the first end joins with a first portion of the perimeter wall, the second end joins with a second portion of the perimeter wall, the bridge extends across the hollow core between the first and second portions of the perimeter wall; the filament is positioned under the bridge.
47. The system of claim 46, wherein the perimeter wall comprises a first perimeter wall and a second perimeter wall, the first perimeter wall comprising the first portion, the second perimeter wall comprises the second portion, the bridge extends from the first perimeter wall to the second perimeter wall through the hollow core.

48. The system of claim 35, wherein the wick comprises a perimeter wall and a bridge, the bridge has a first end and a second end, the first end joins with a first portion of the perimeter wall, the second end joins with a second portion of the perimeter wall, the bridge extends across the hollow core between the first and second portions of the perimeter wall; the filament is positioned under the bridge and adjacent a portion of the perimeter wall.
49. The system of claim 35, wherein the wick comprises a shape selected from the group consisting of a circle, an ellipse, a quadrilateral, a rectangle, and a spiral.
50. The system of claim 47, comprising a solid wax positioned on the melting grate so that a priming portion of the solid wax is positioned above the bridge and the filament.
51. A method of operating a wax burning system, comprising the steps of:
- locating a solid fuel on a melting grate adjacent to a wick, the solid fuel having a priming section, the wick comprising a hollow core;
  - positioning the priming section adjacent the wick;
  - heating at least a portion of the priming section with a filament adjacent the wick so that a portion of the priming section melts and falls onto the wick, the filament is within the hollow core of the wick;
  - igniting, with heat from the filament, the wick when the wick comprises a sufficient amount of fuel to support a flame.
52. The method of claim 51, wherein the step of heating comprises supplying power to the filament from a power source.

53. The method of claim 51, wherein the step of positioning, comprises positioning the priming section adjacent the filament.
54. The method of claim 51, wherein the step of heating comprises heating the filament to above 375 degrees Fahrenheit.
55. The method of claim 51, wherein the step of heating comprises the step of activating a power which of an electronic circuit to cause power from a power source to be directed to the filament to cause the filament to generate heat.
56. The method of claim 51, wherein,
- the step of positioning comprises the step of positioning the priming section adjacent a bridge, wherein the wick comprises the bridge, a perimeter wall, the bridge extends across the hollow core between a first portion and a second portion of the perimeter wall;
  - the step of heating comprises heating at least a portion of the priming section with a filament adjacent the bridge so that a portion of the priming section melts and falls onto the bridge;
  - the step of igniting comprises igniting, with heat from the filament, the bridge when the bridge comprises a sufficient amount of fuel to support a flame;
- and wherein the method of operating a wax burning system comprises the step of transferring the flame from the bridge to the perimeter wall of the wick.

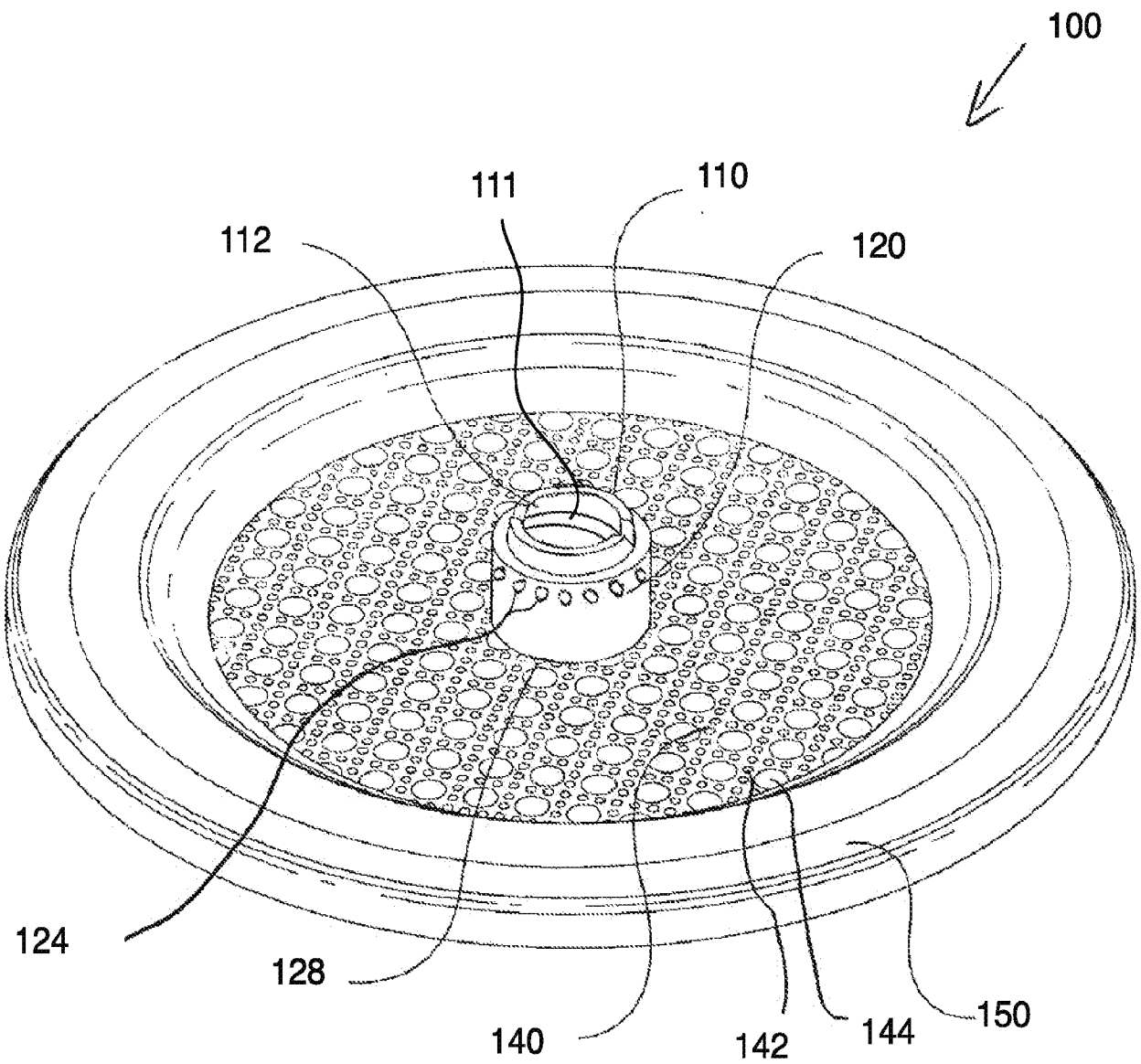

Fig. 1

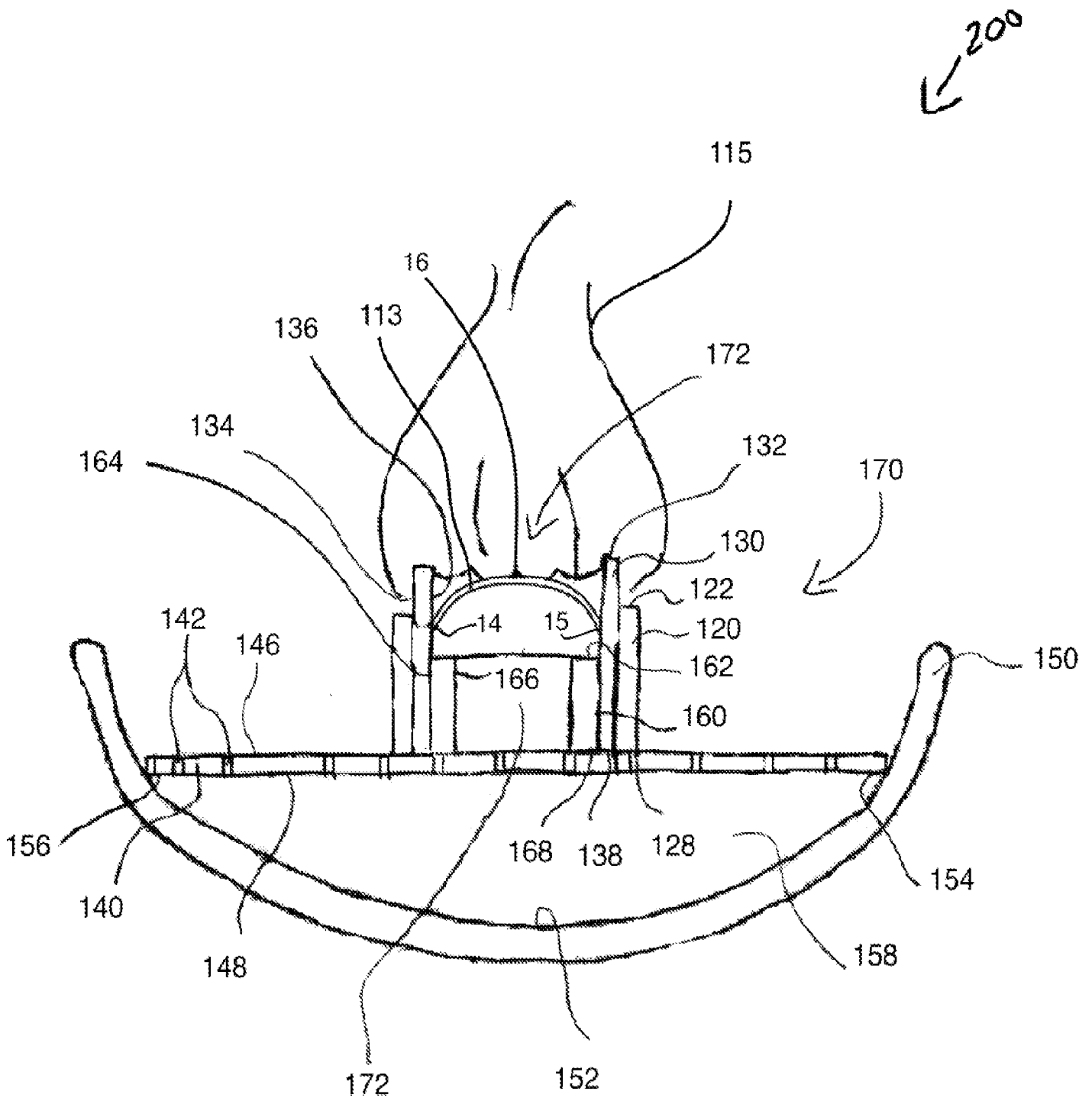

Fig. 2

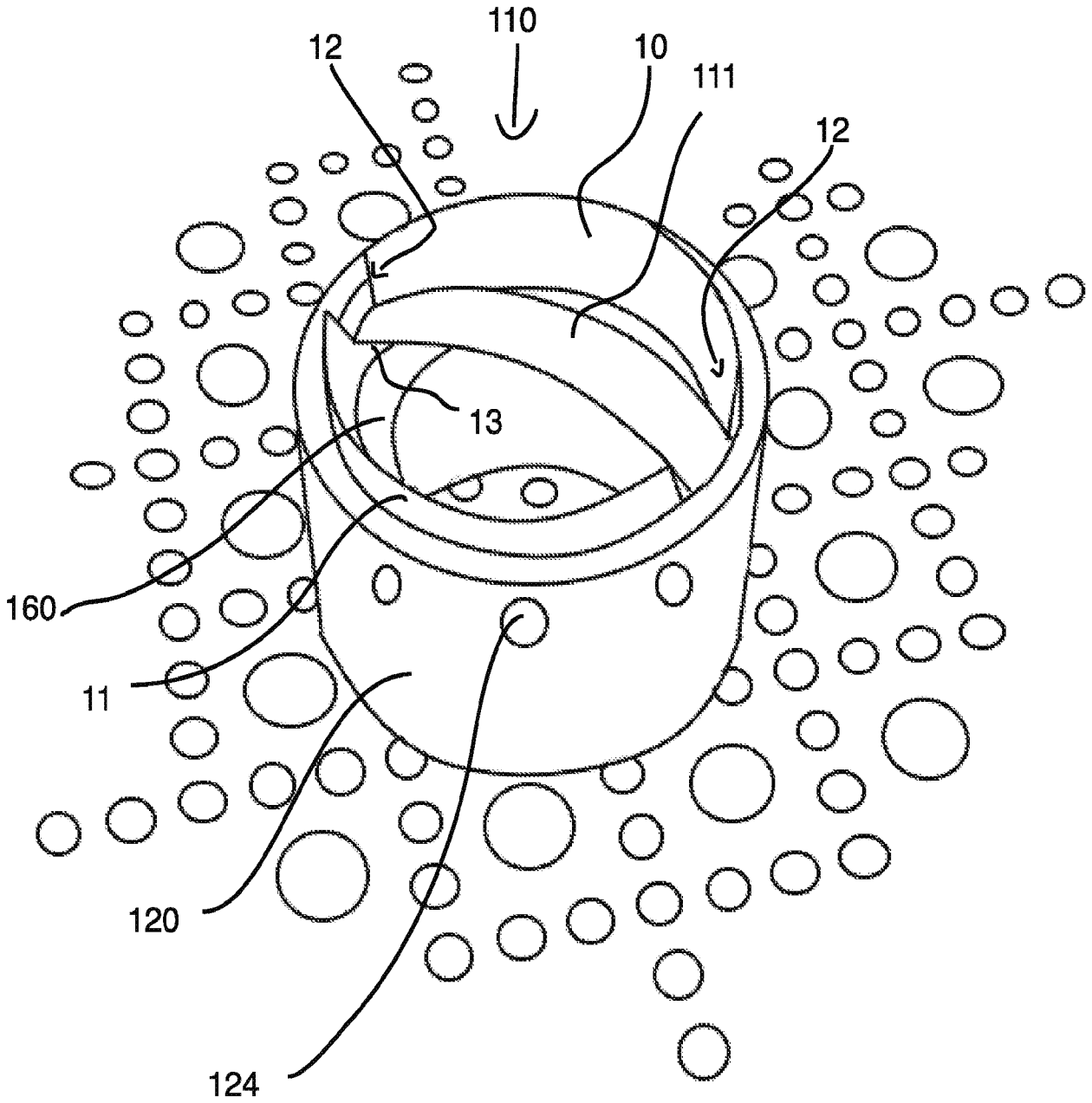

Fig. 3

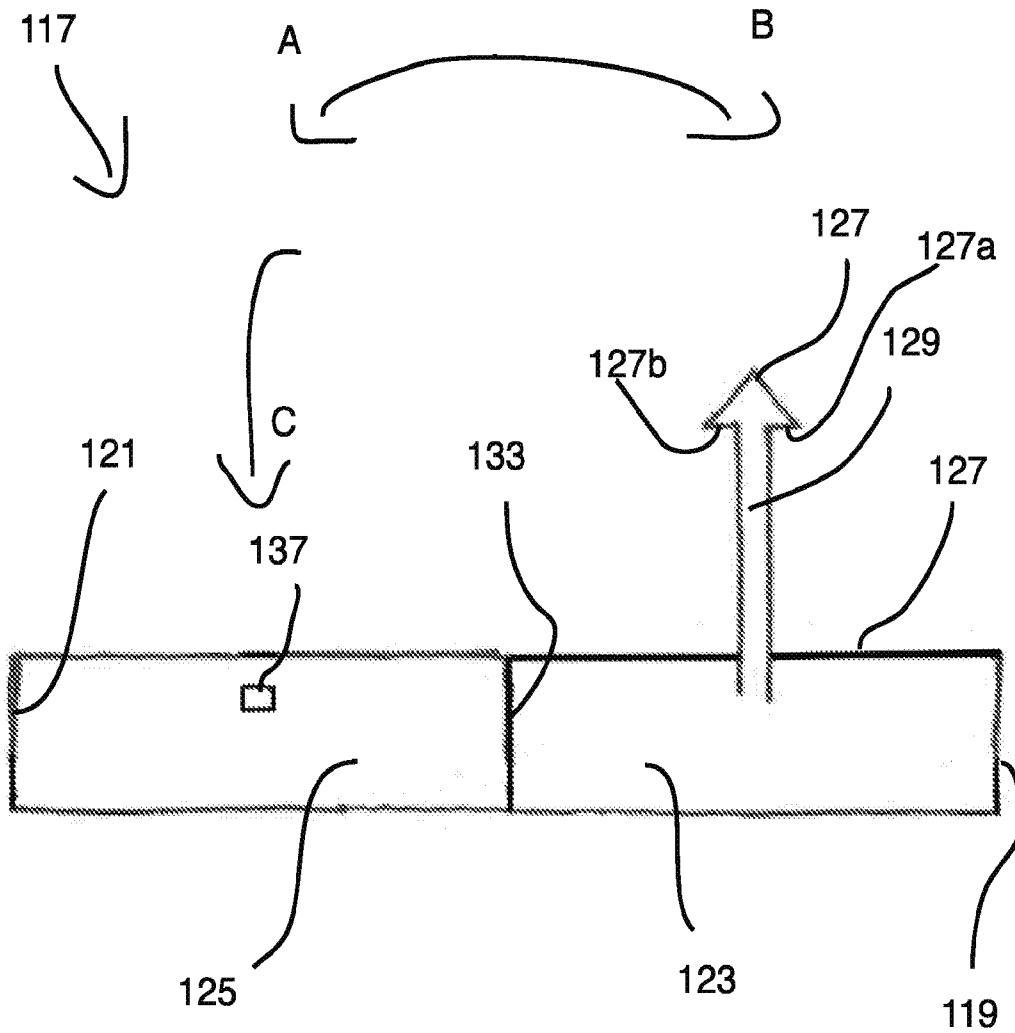

Fig. 4

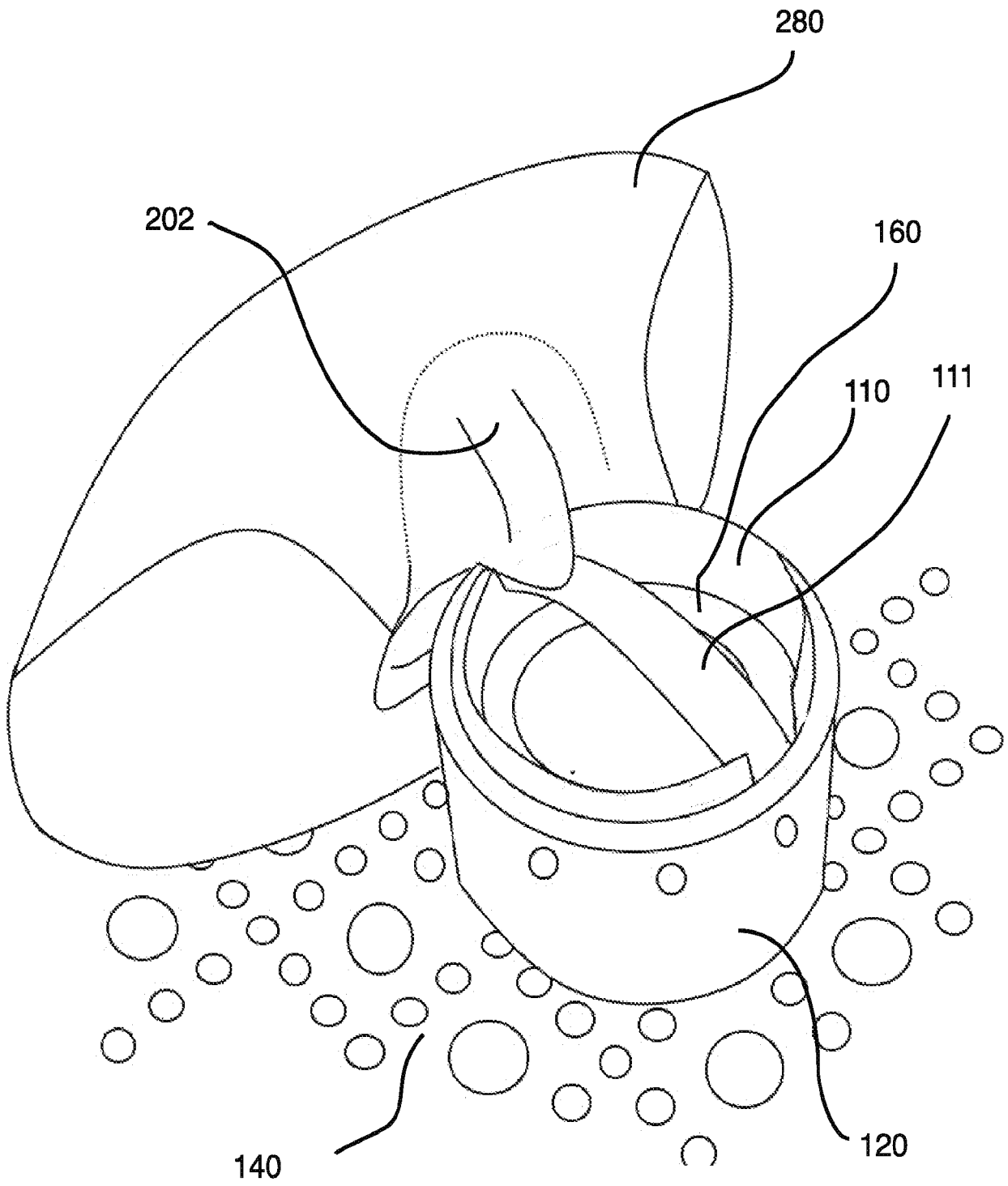

Fig. 5

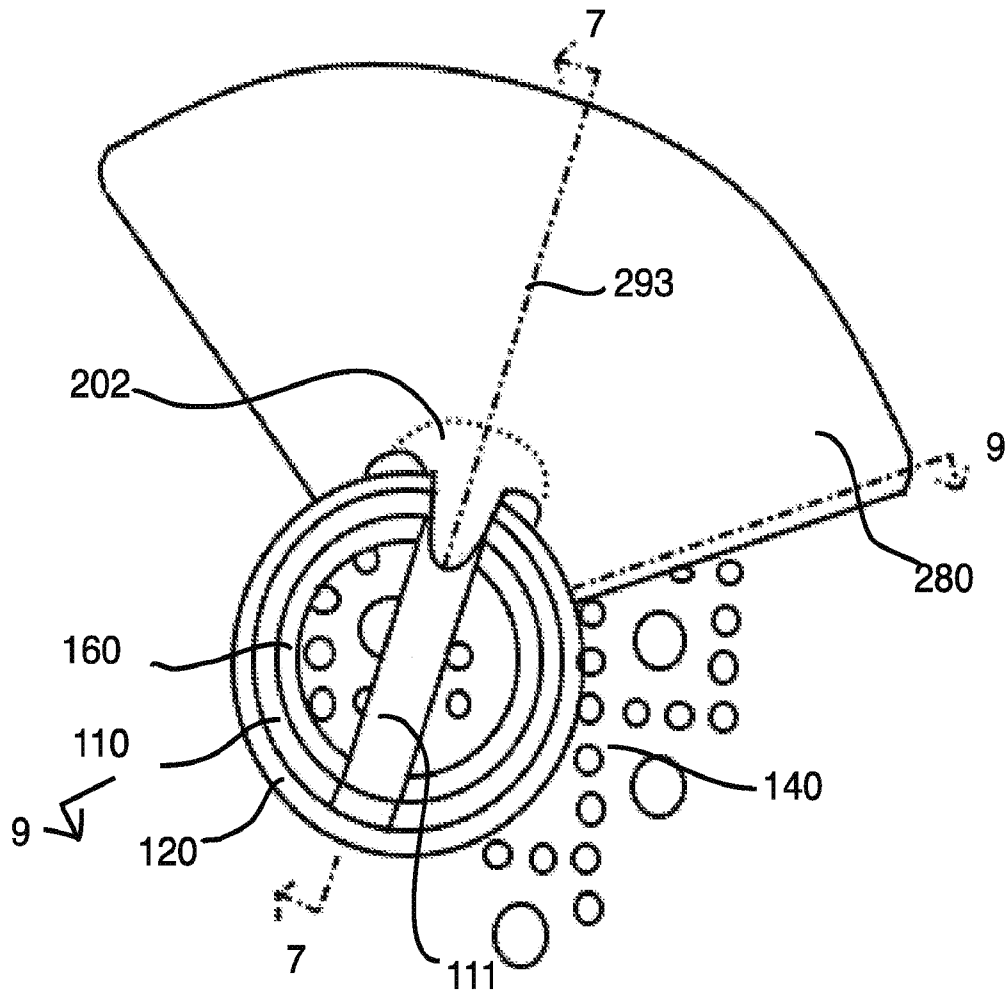

Fig. 6

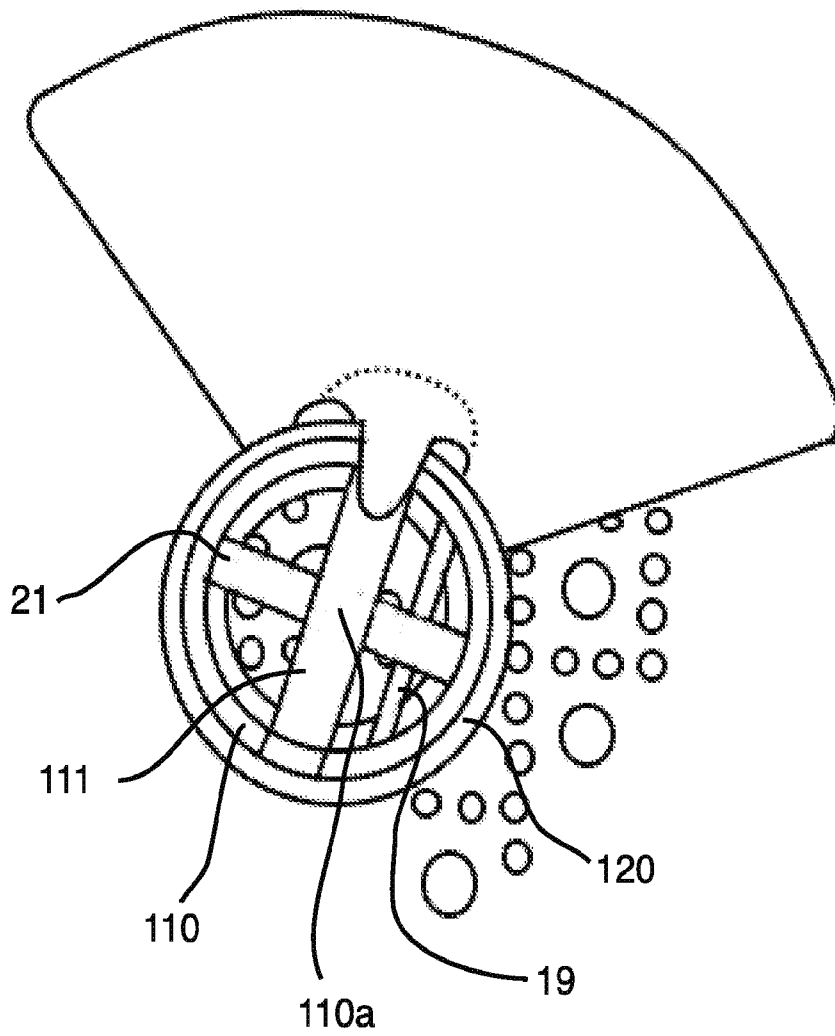

Fig. 6A

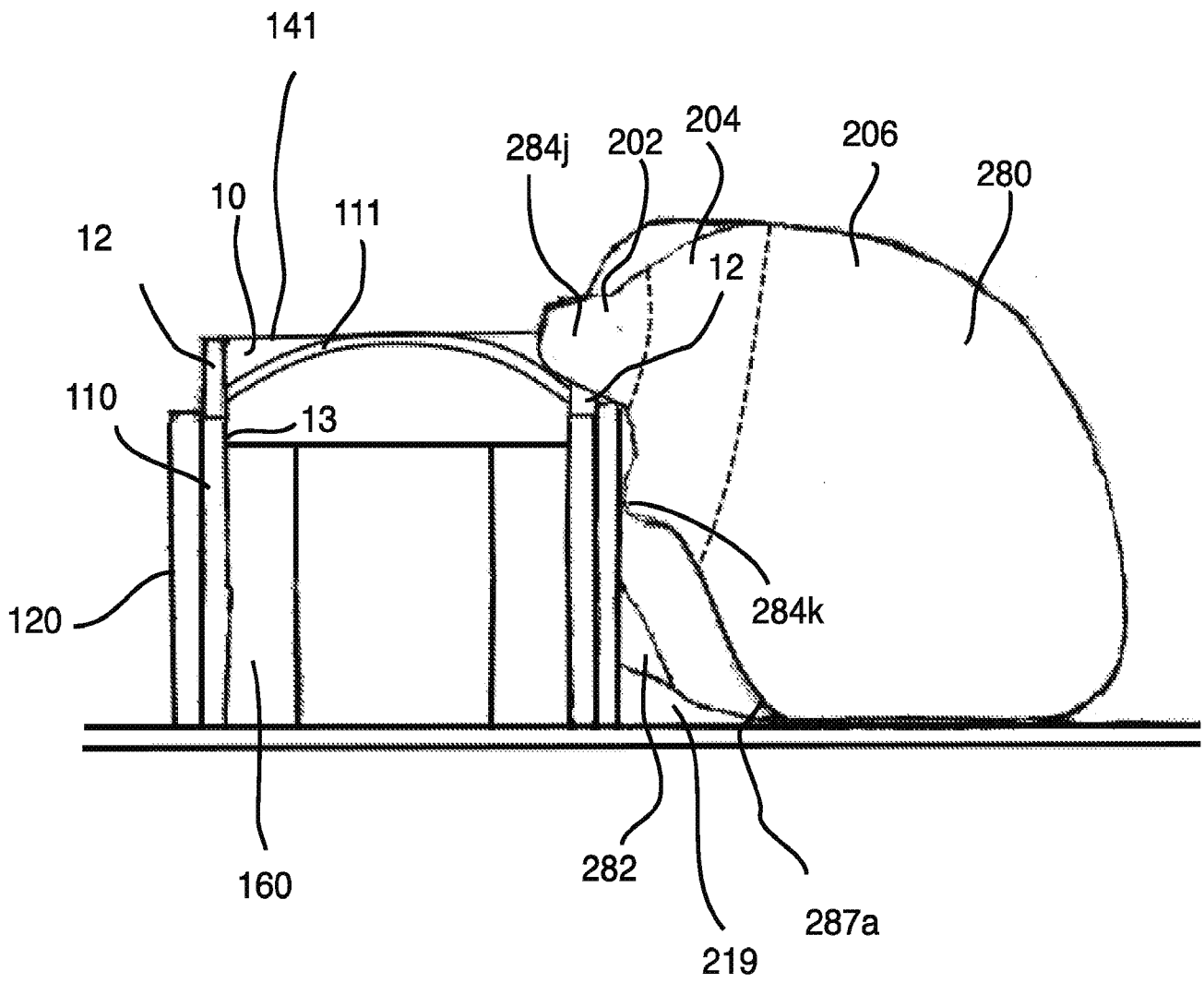

Fig. 7

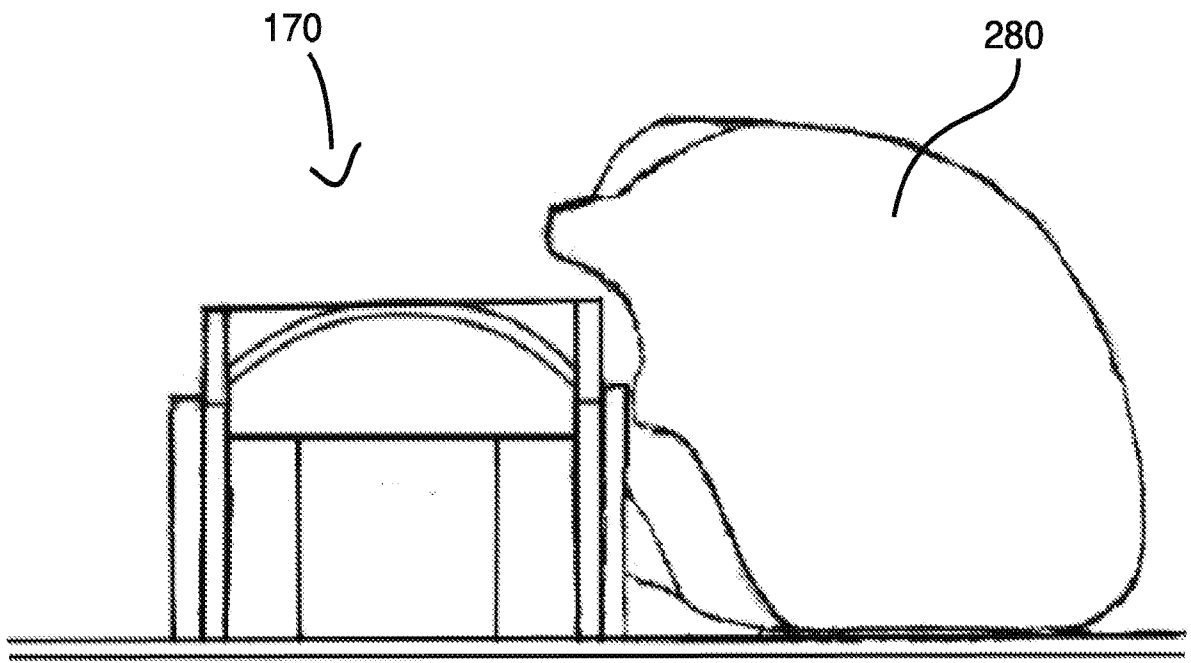

Fig. 8

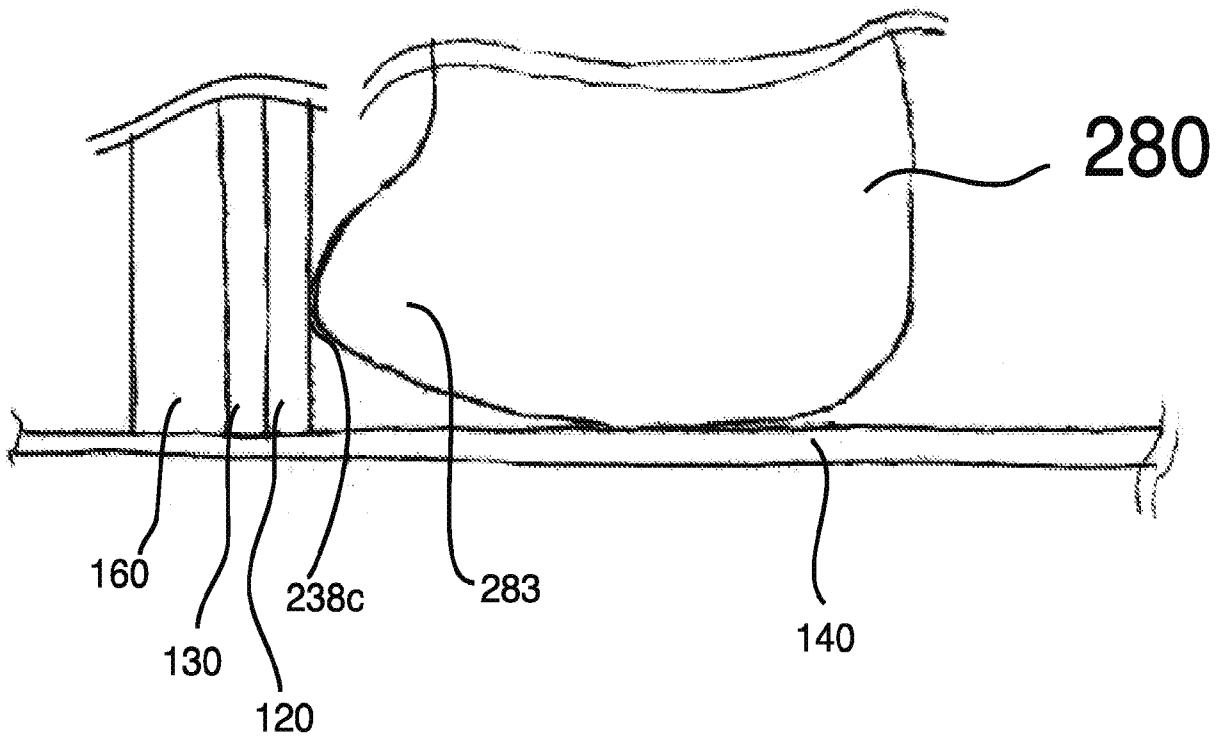

Fig. 9

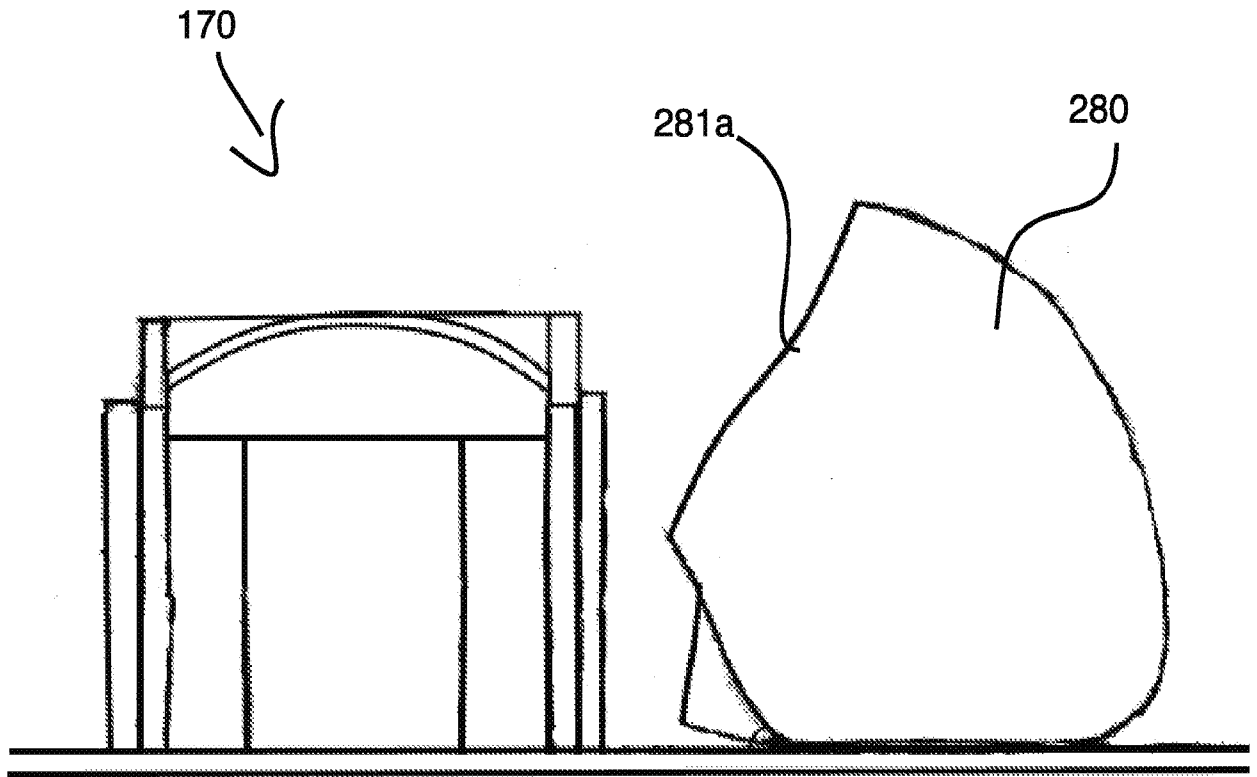

Fig. 10

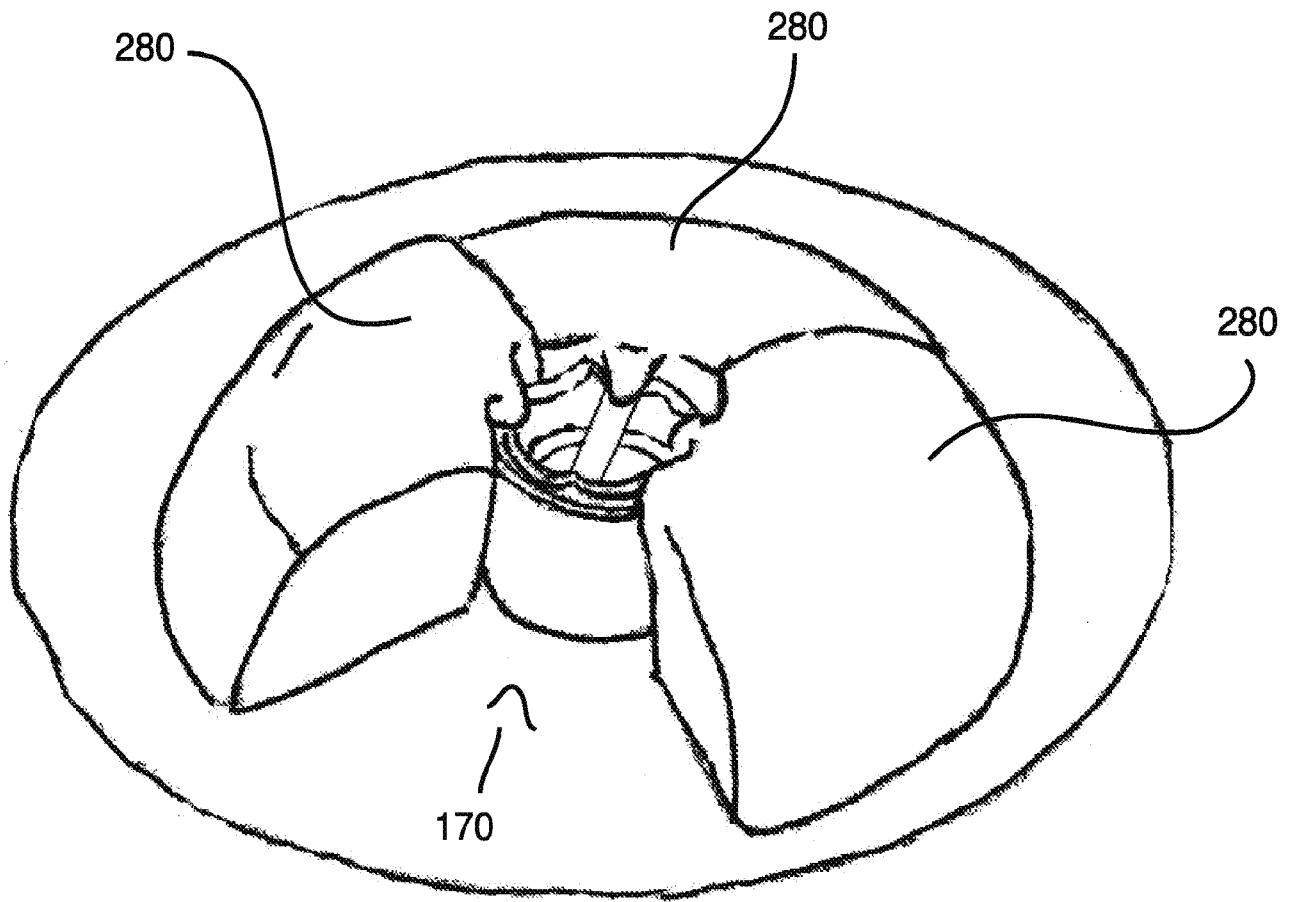

Fig. 11

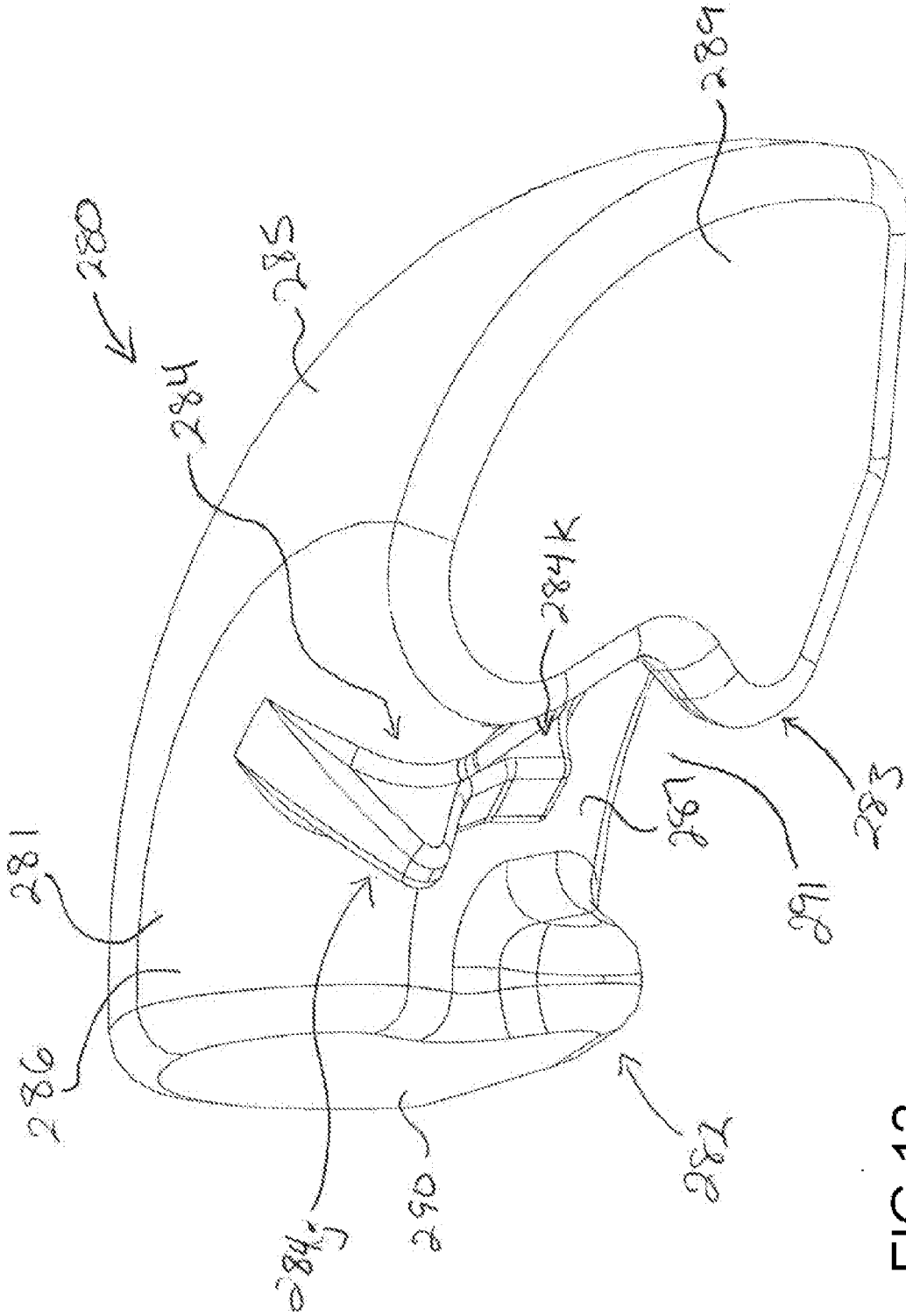

FIG 12

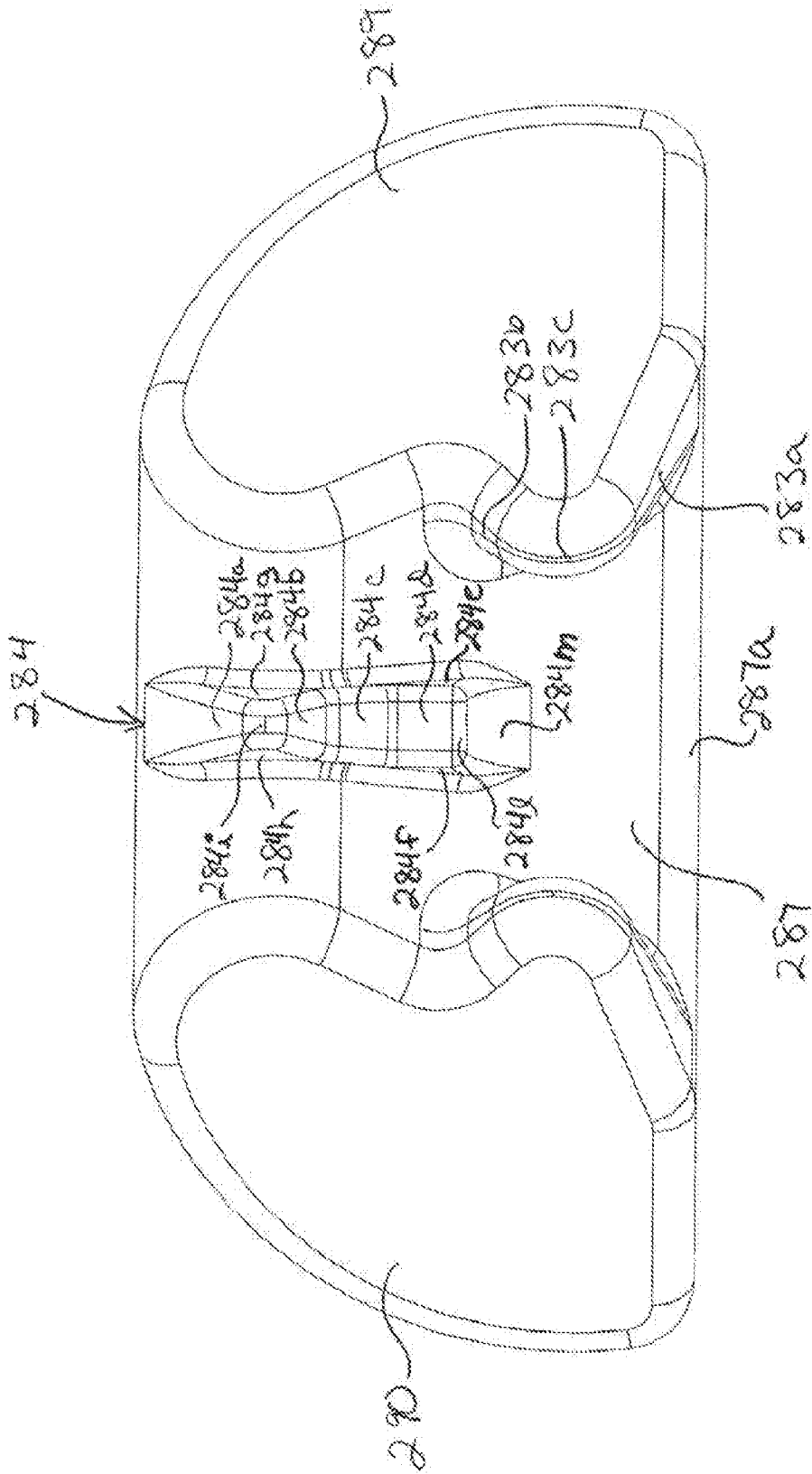

FIG 13

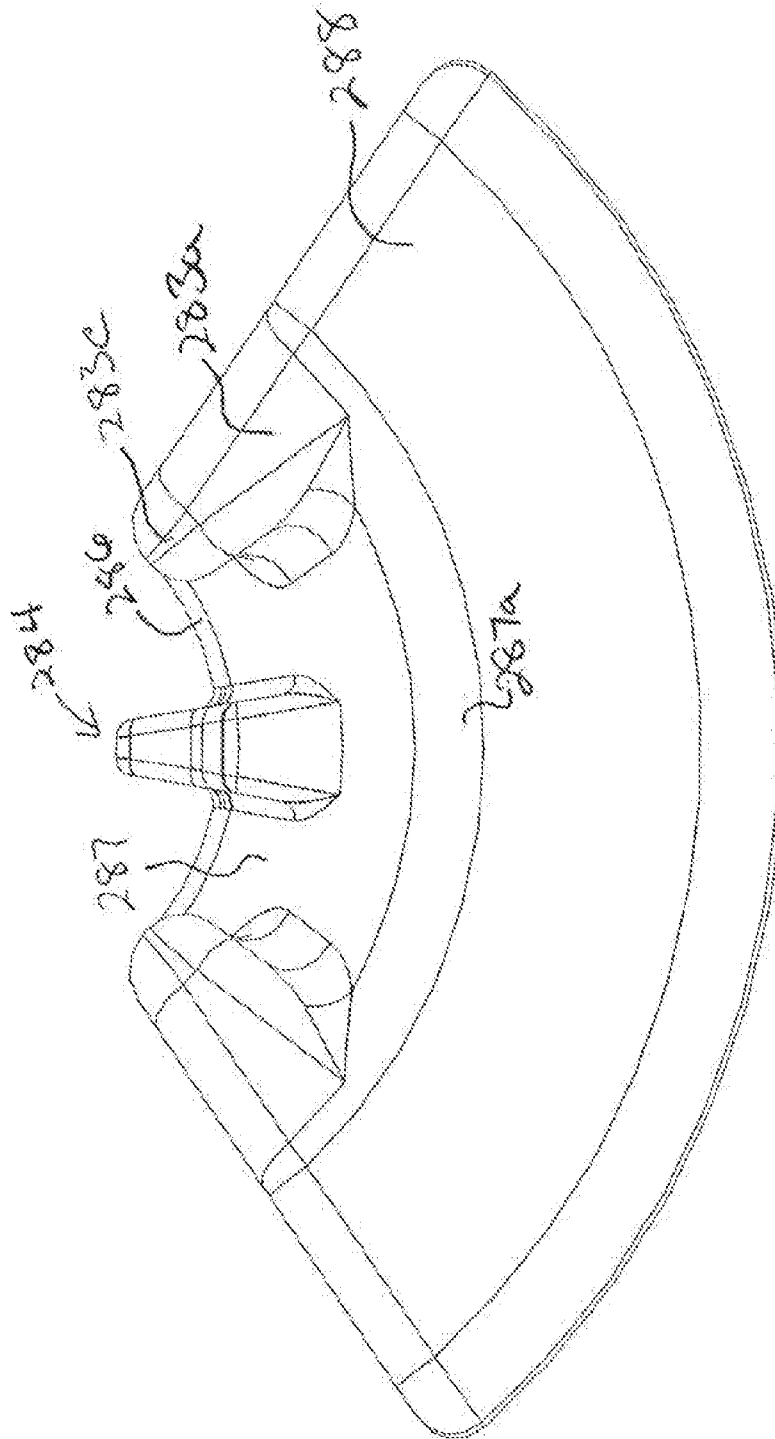

FIG 14

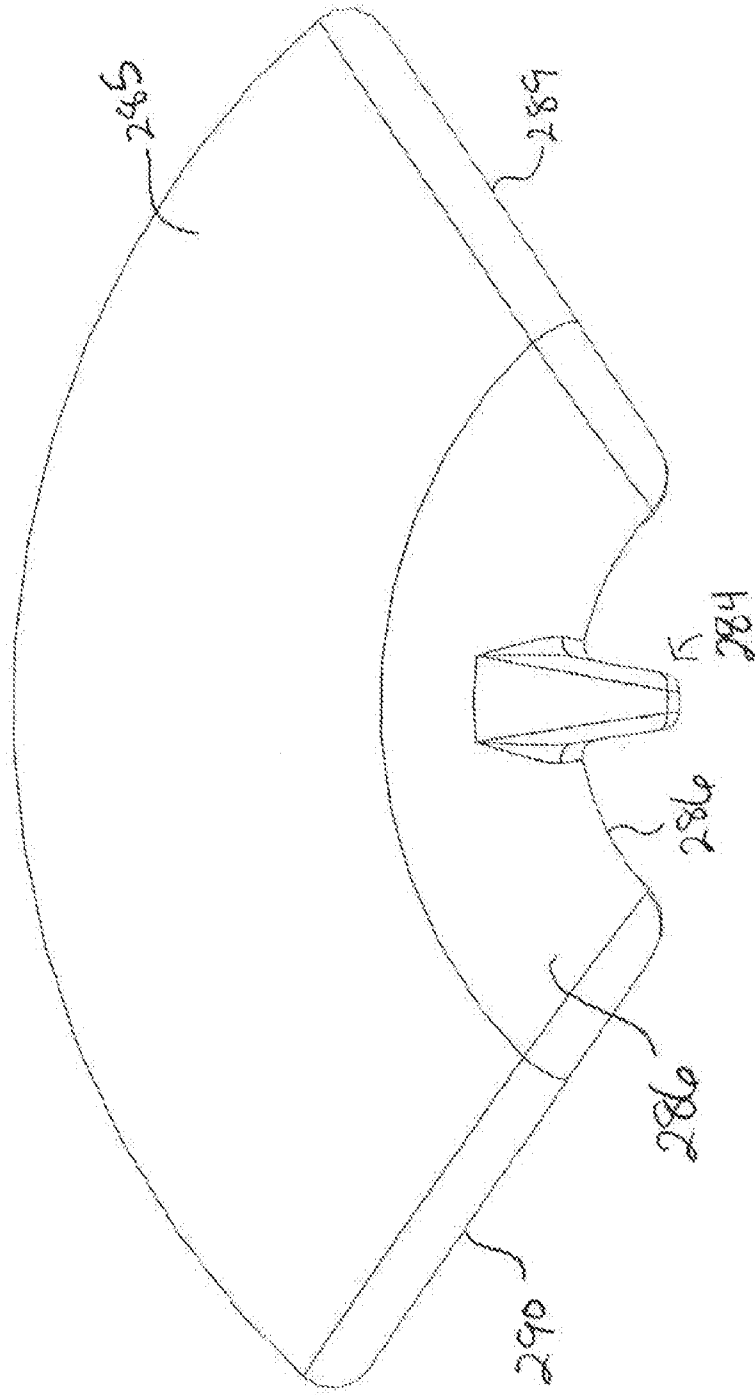

FIG 15

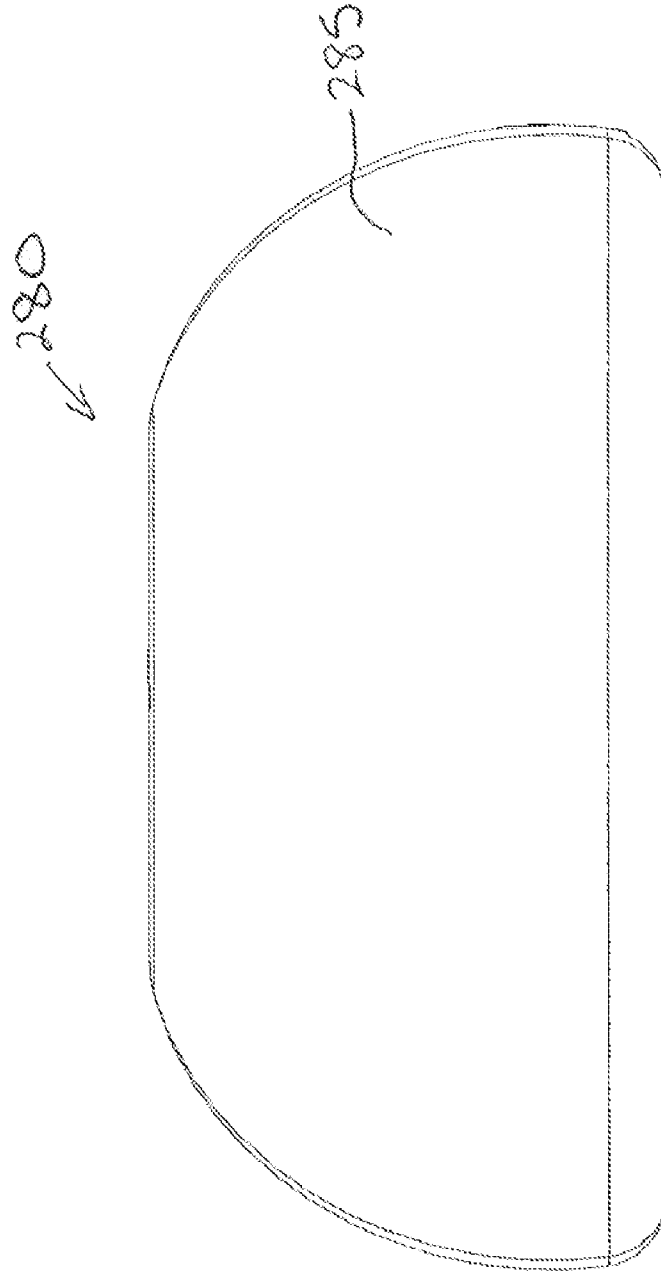

FIG 16

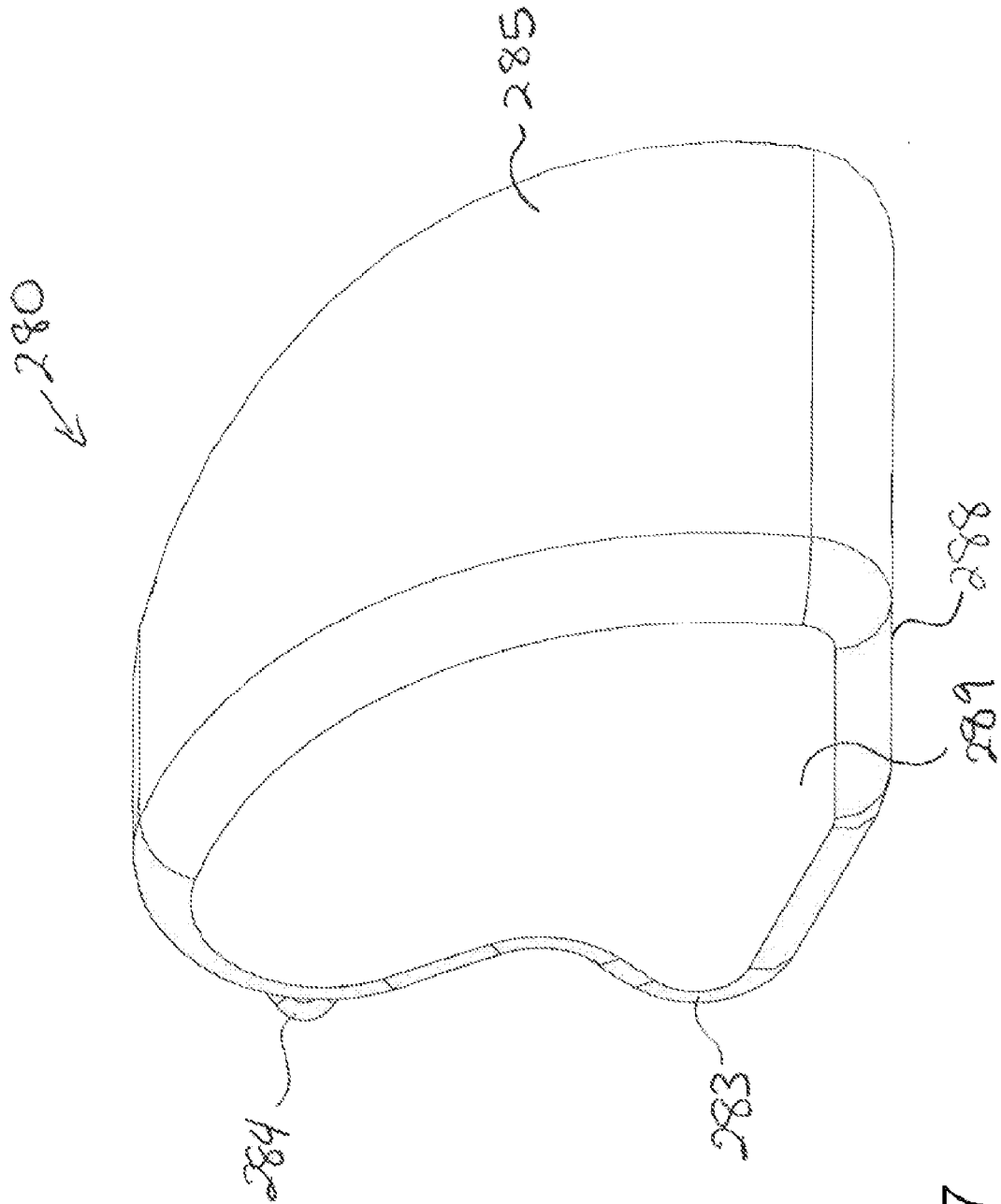
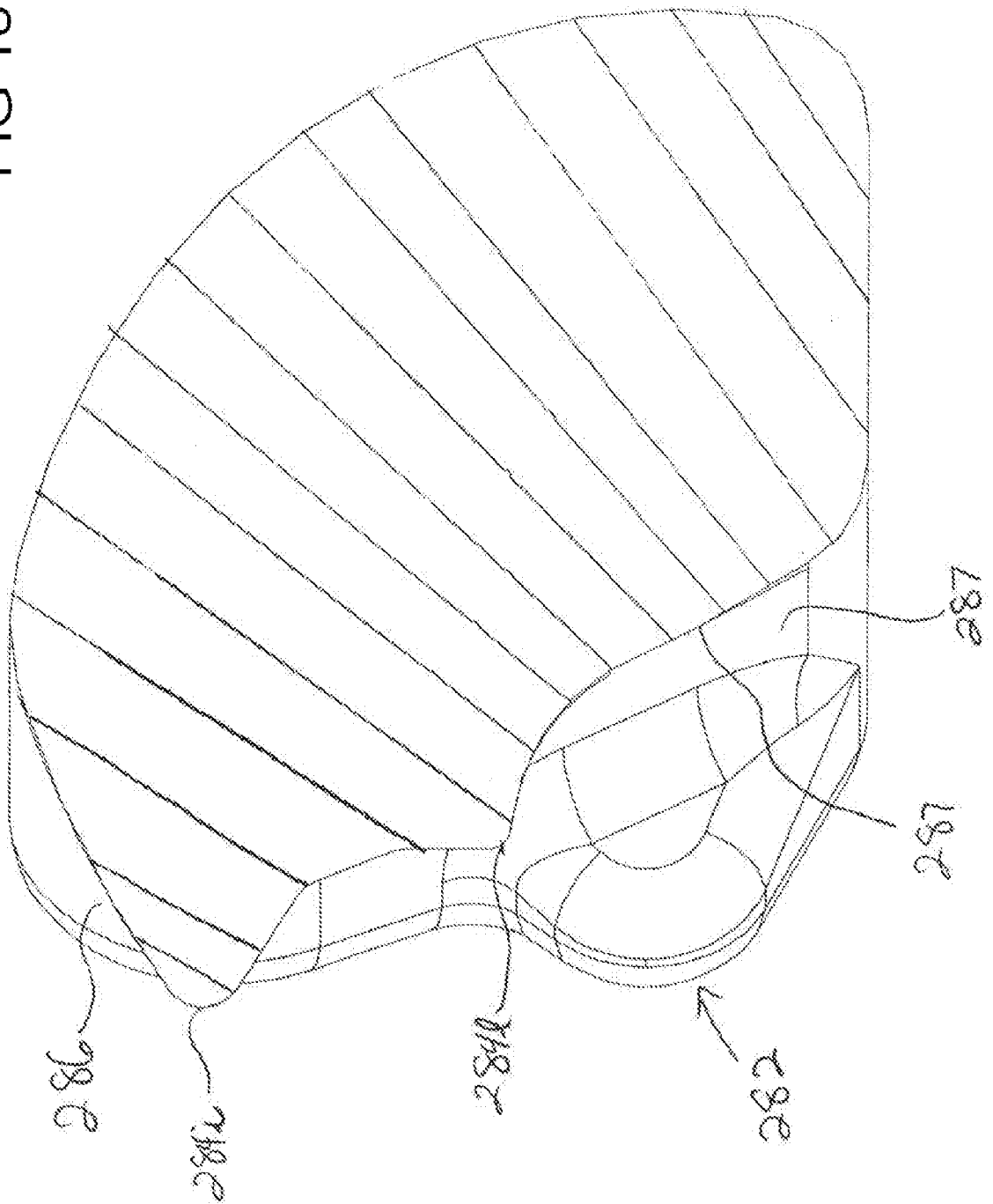

FIG 17

FIG 18





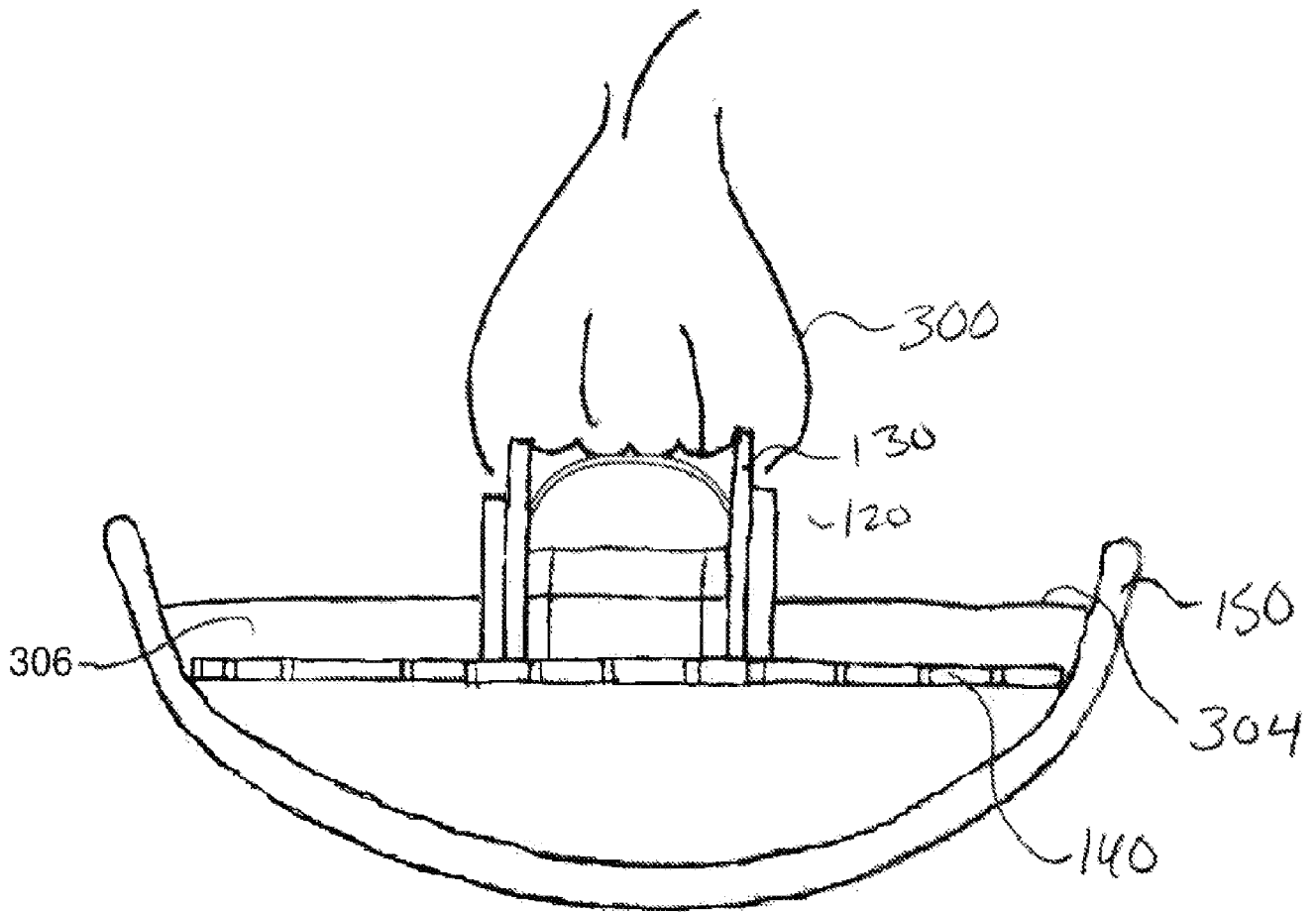

Fig. 20

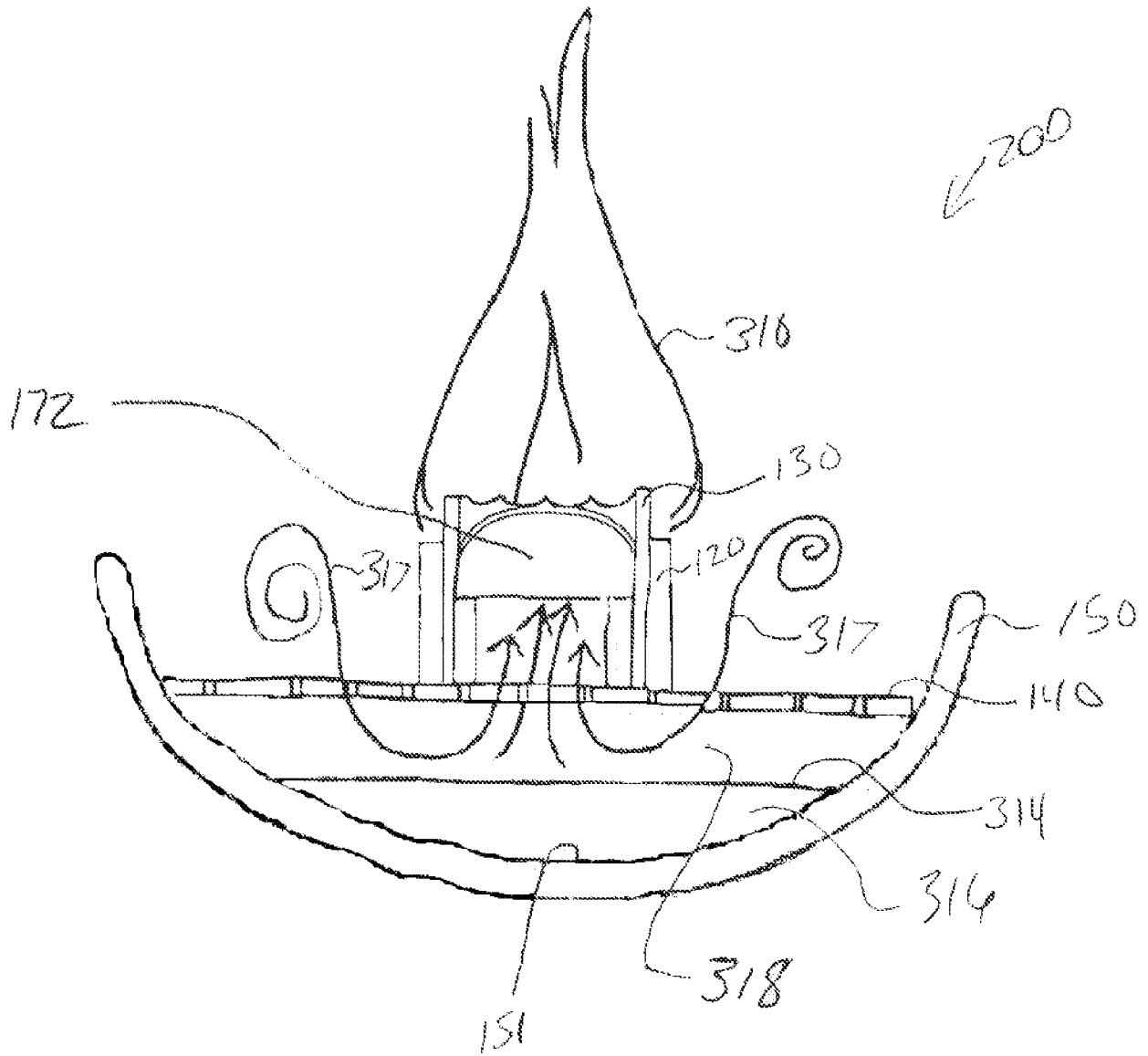

FIG 21

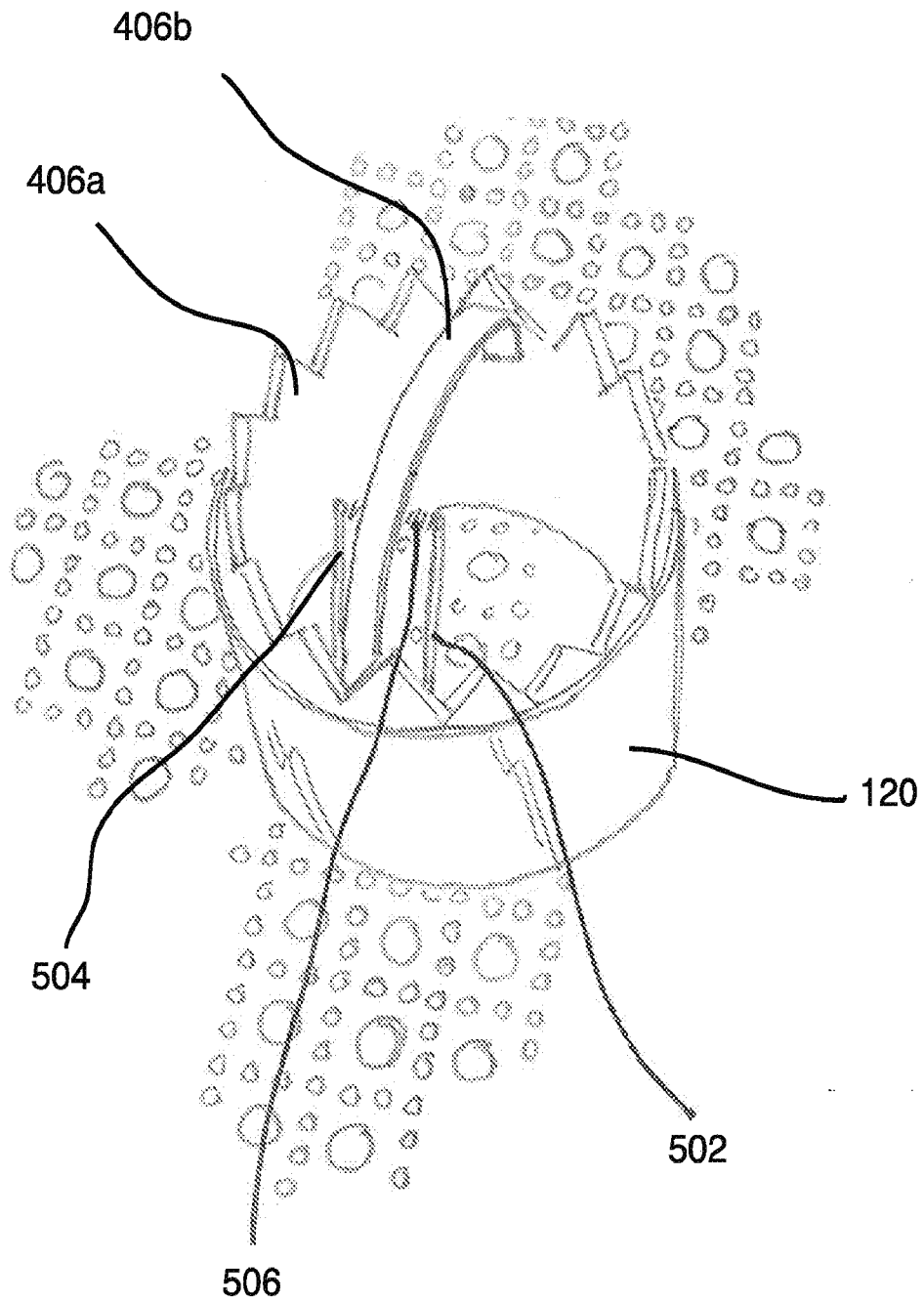

Fig. 22A

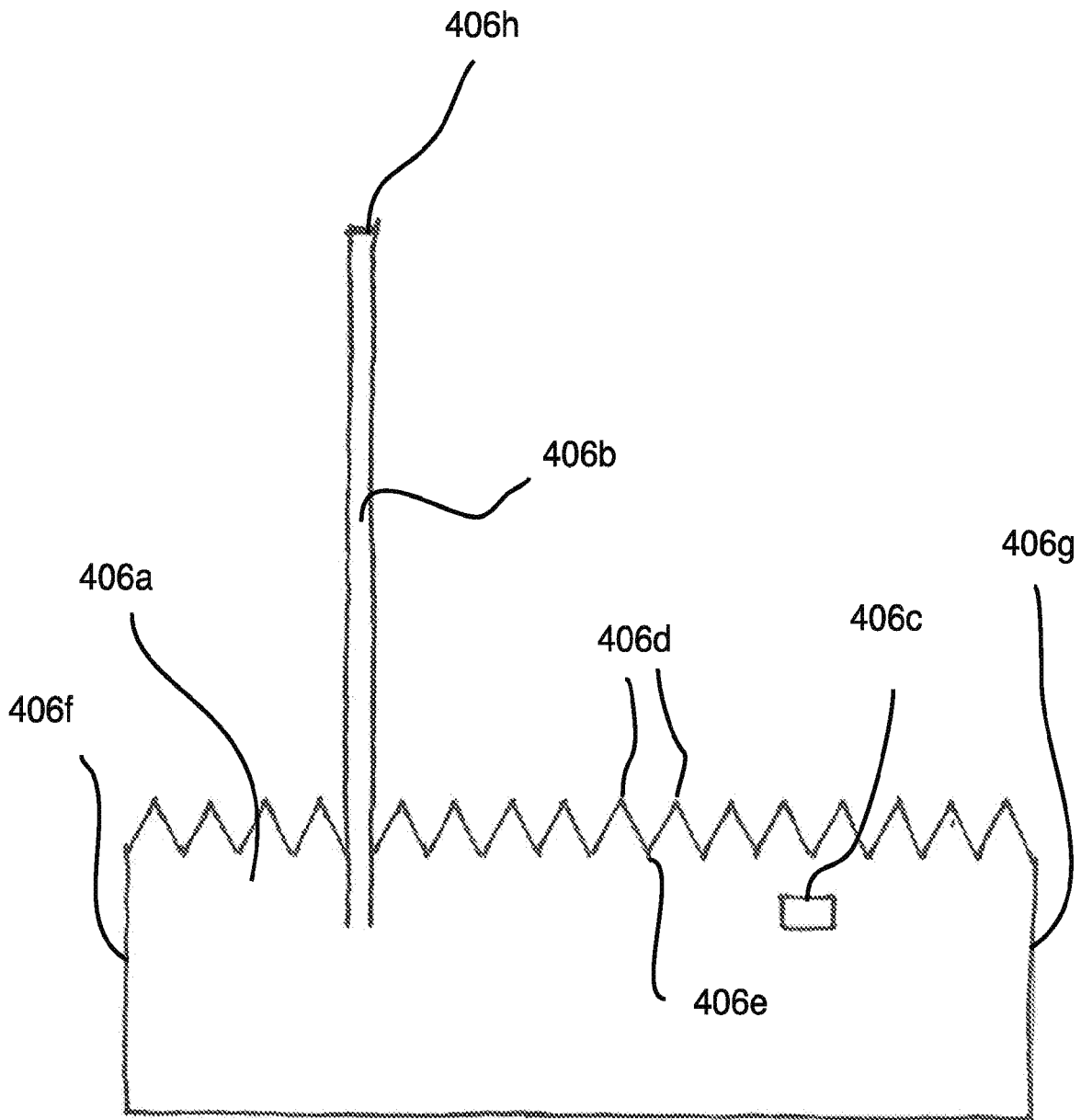

Fig. 22B

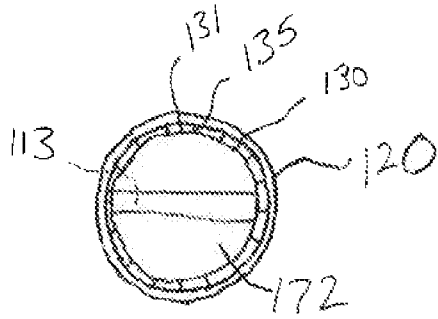

FIG 22C

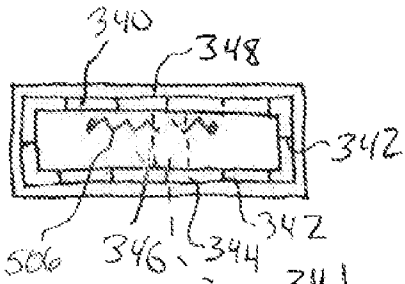

FIG 22D

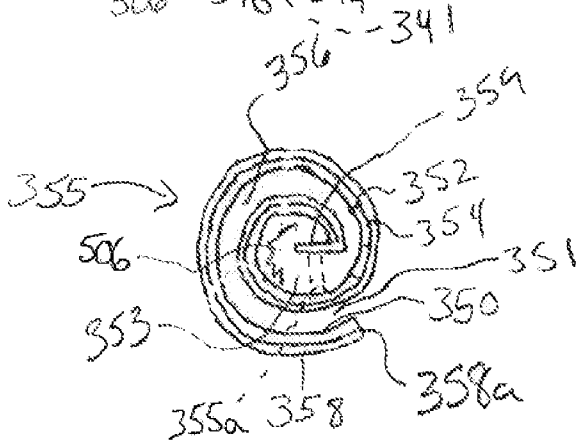

FIG 22E

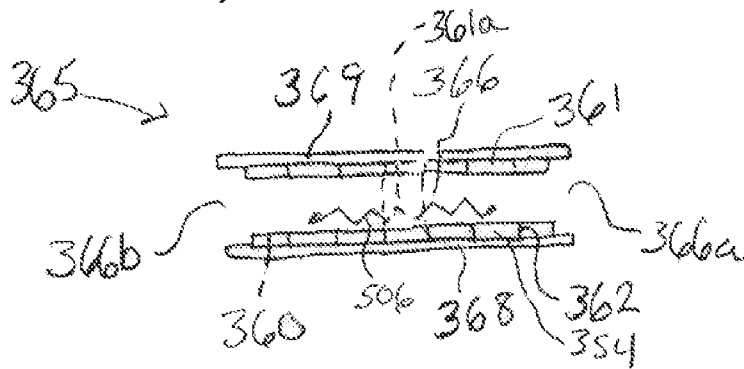

FIG 22F

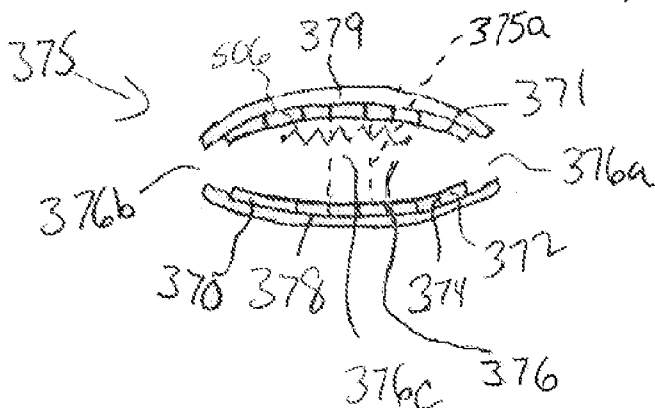

FIG 22G

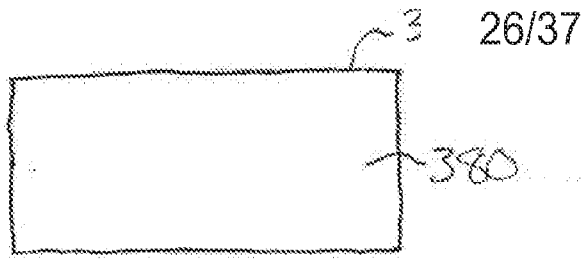

FIG 23

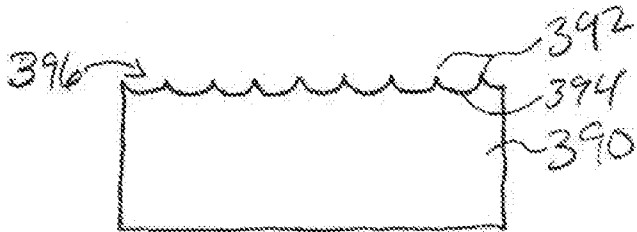

FIG 24

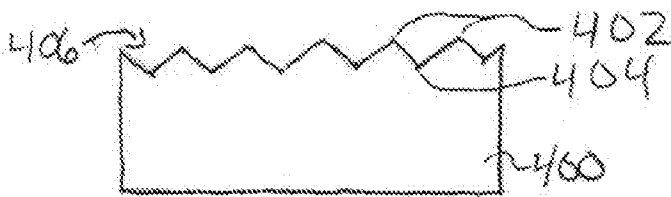

FIG 25

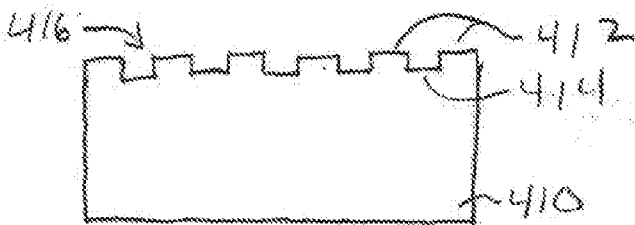

FIG 26



FIG 27



FIG 28

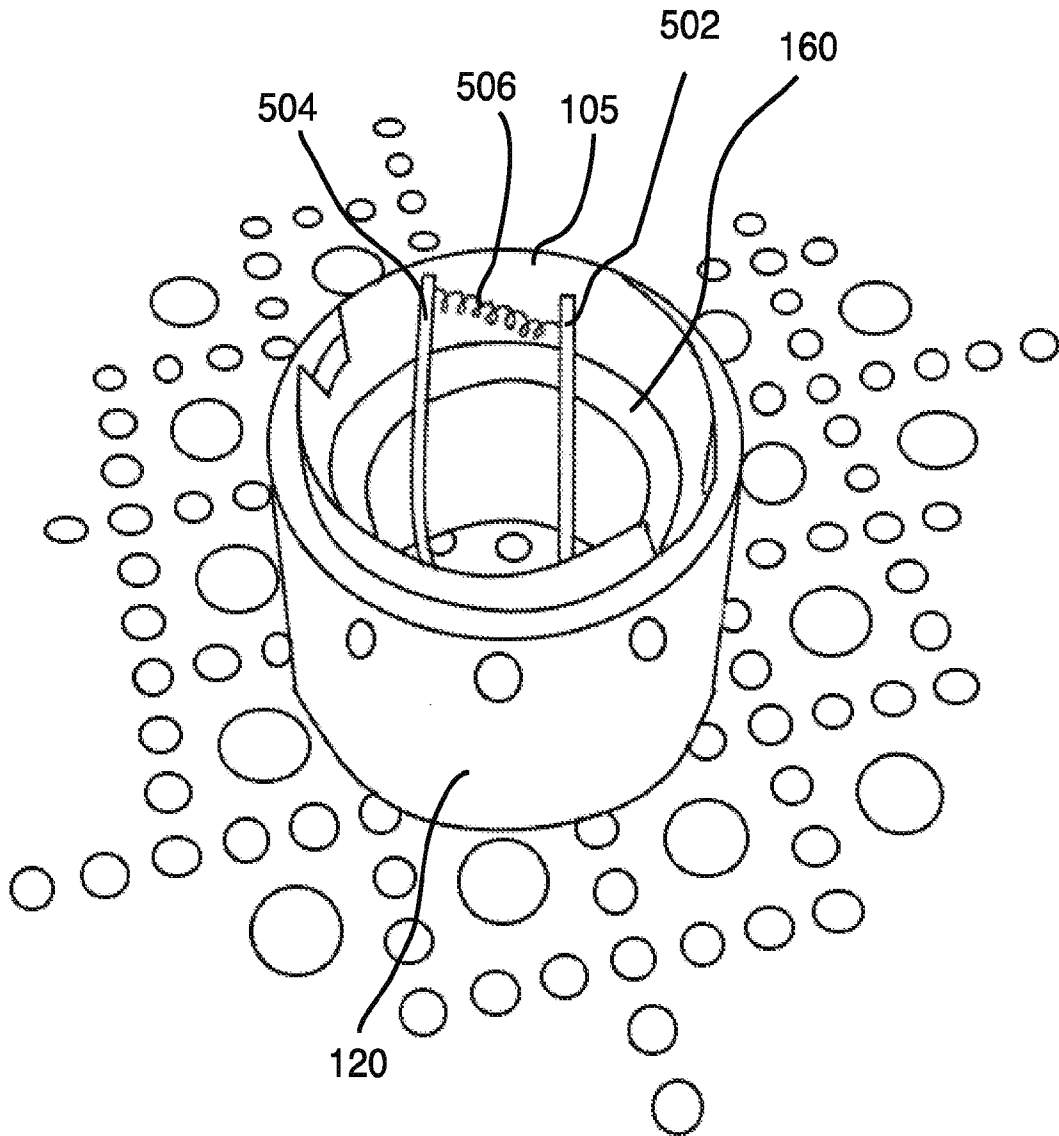

Fig. 29

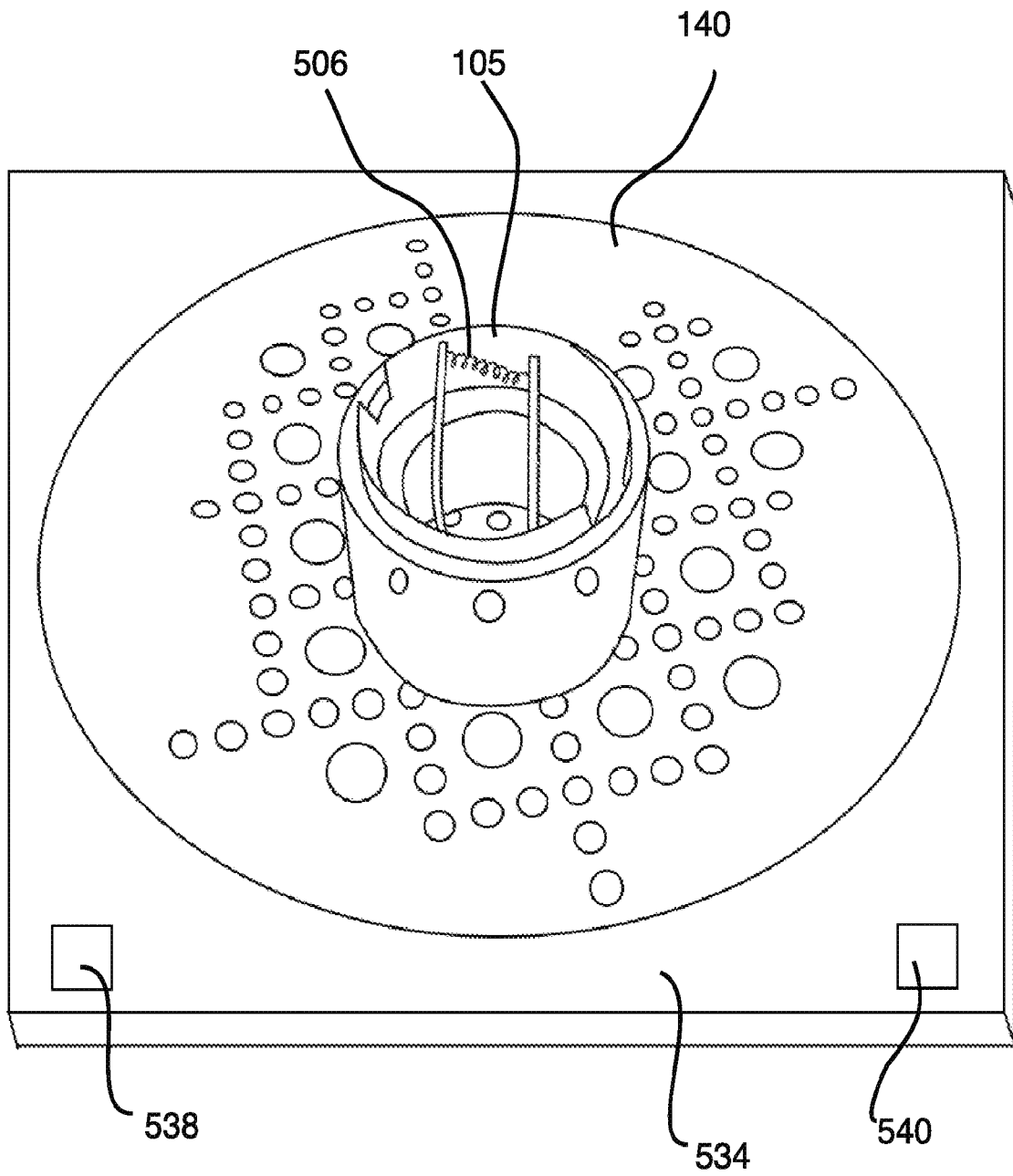

Fig. 29A

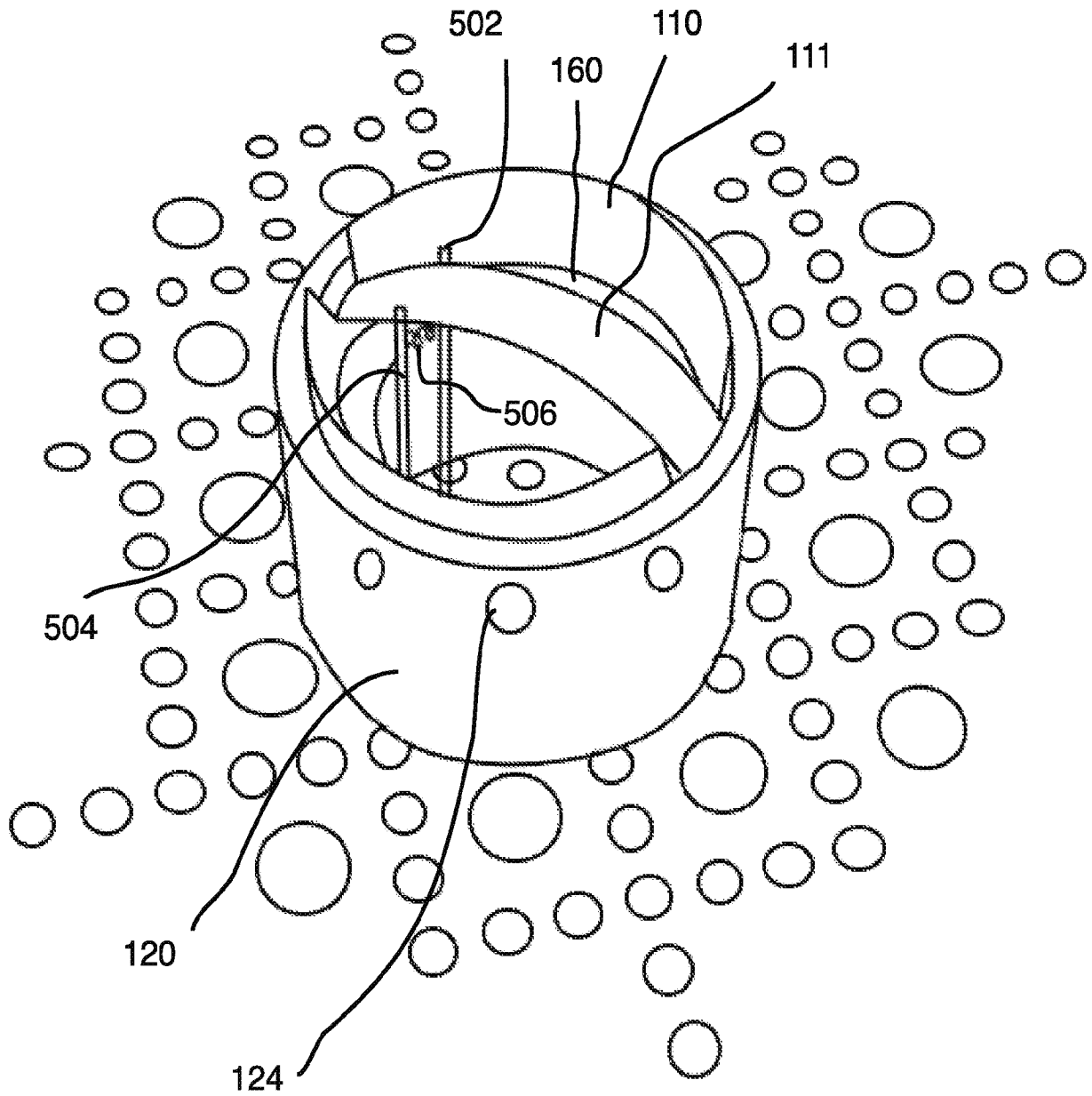

Fig. 30

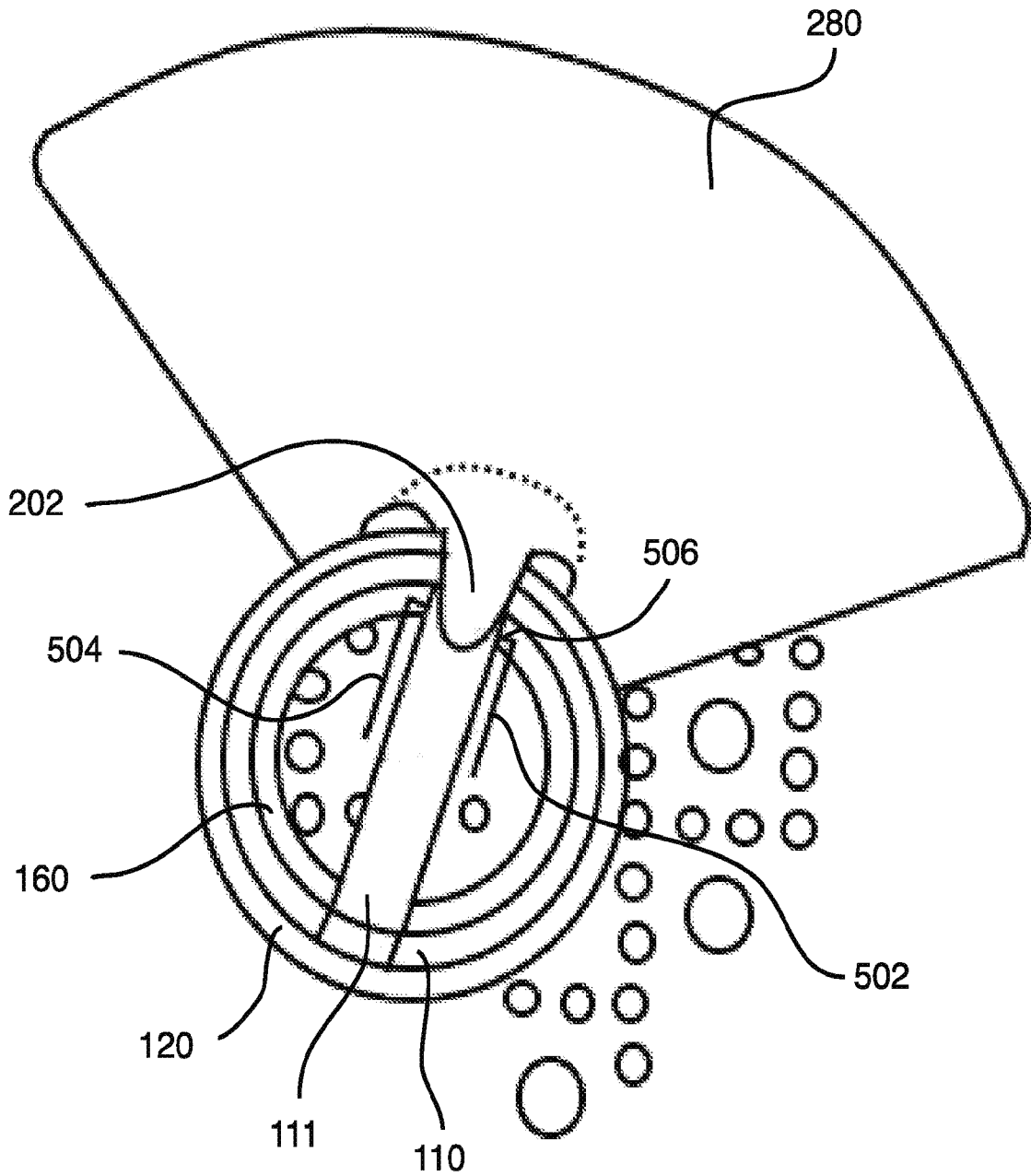

Fig. 31

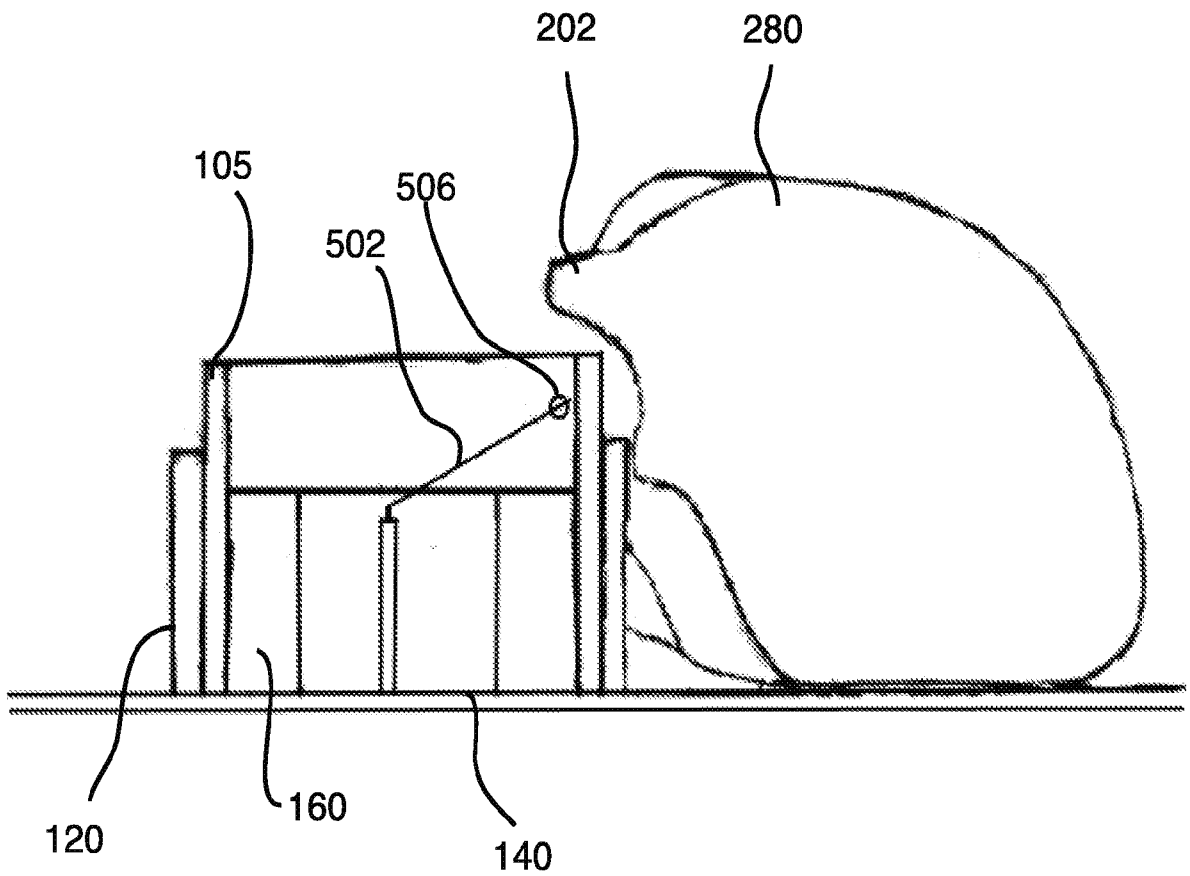

Fig. 32

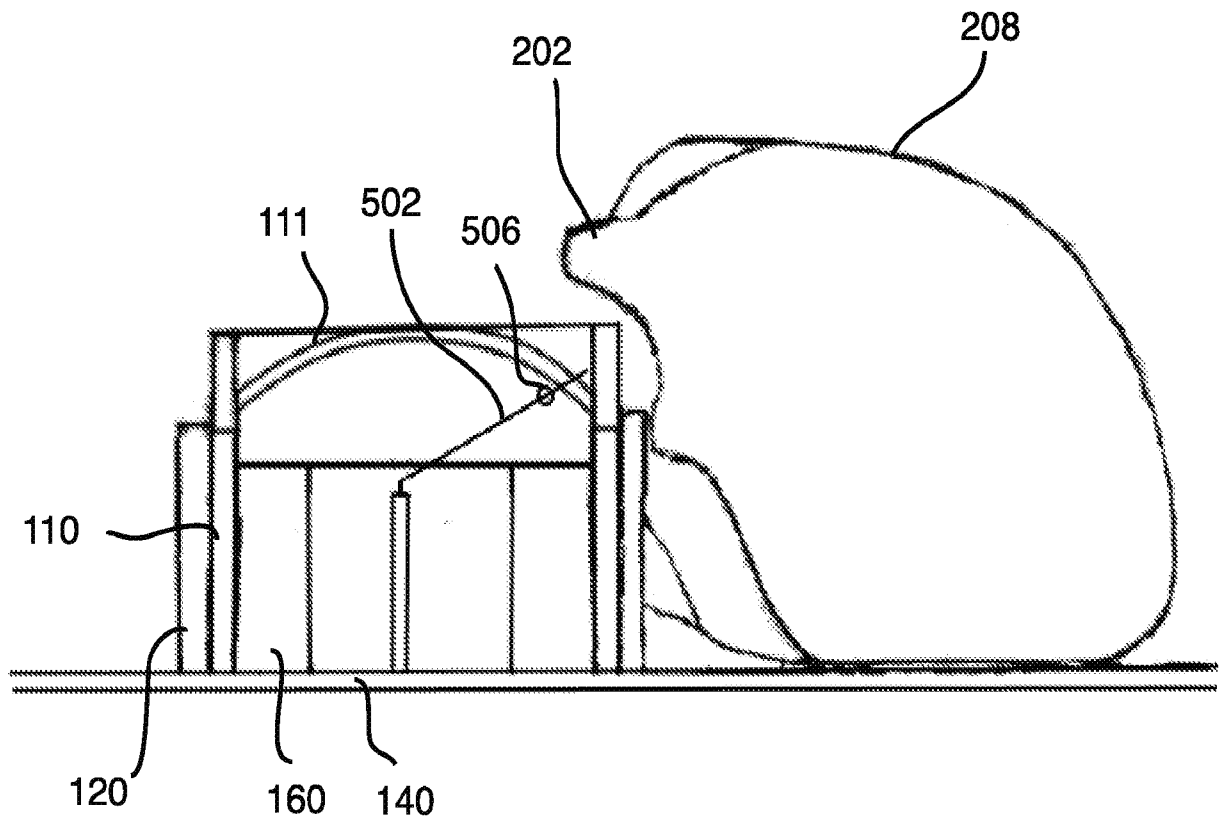

Fig. 33

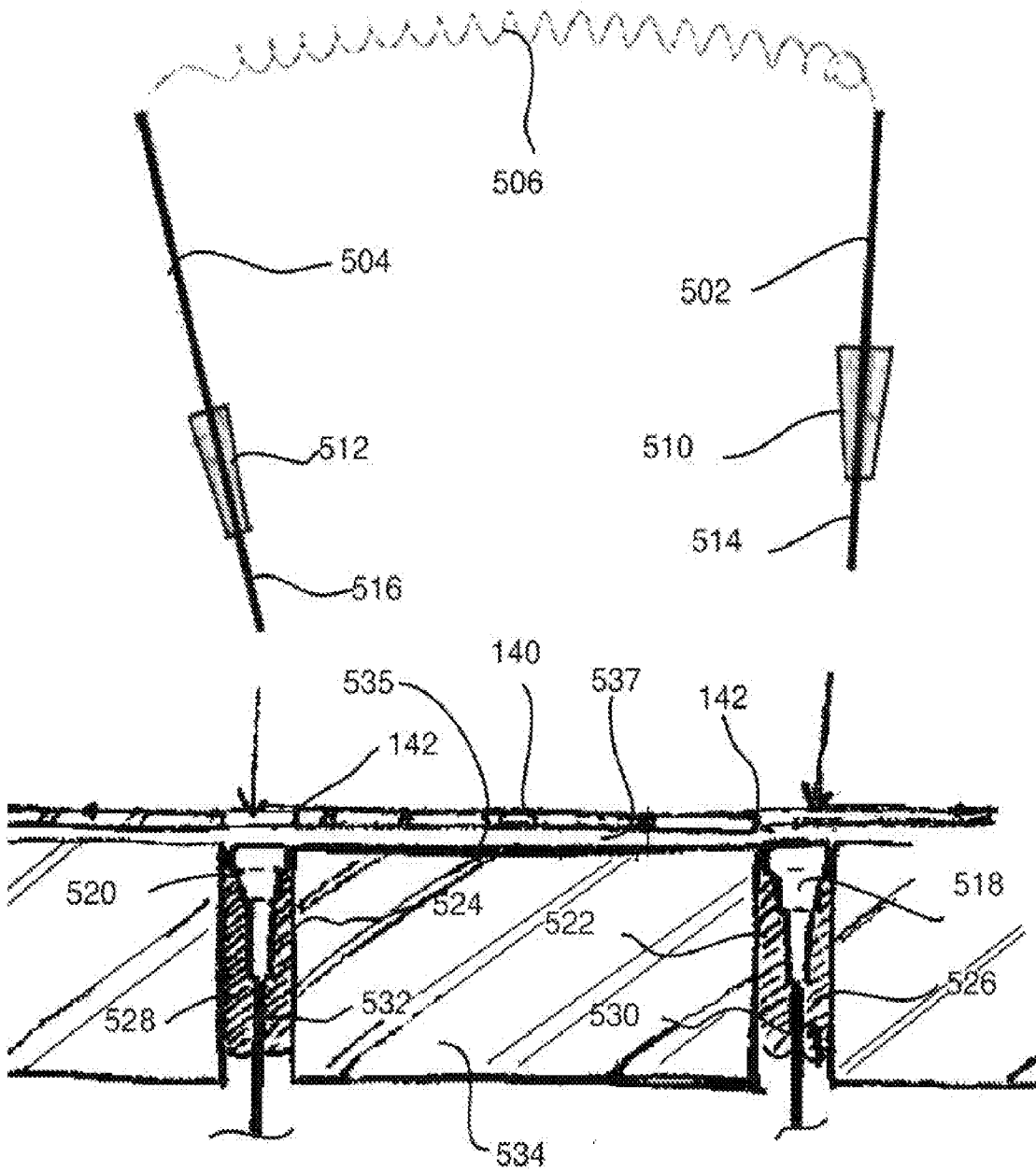

Fig. 34

508

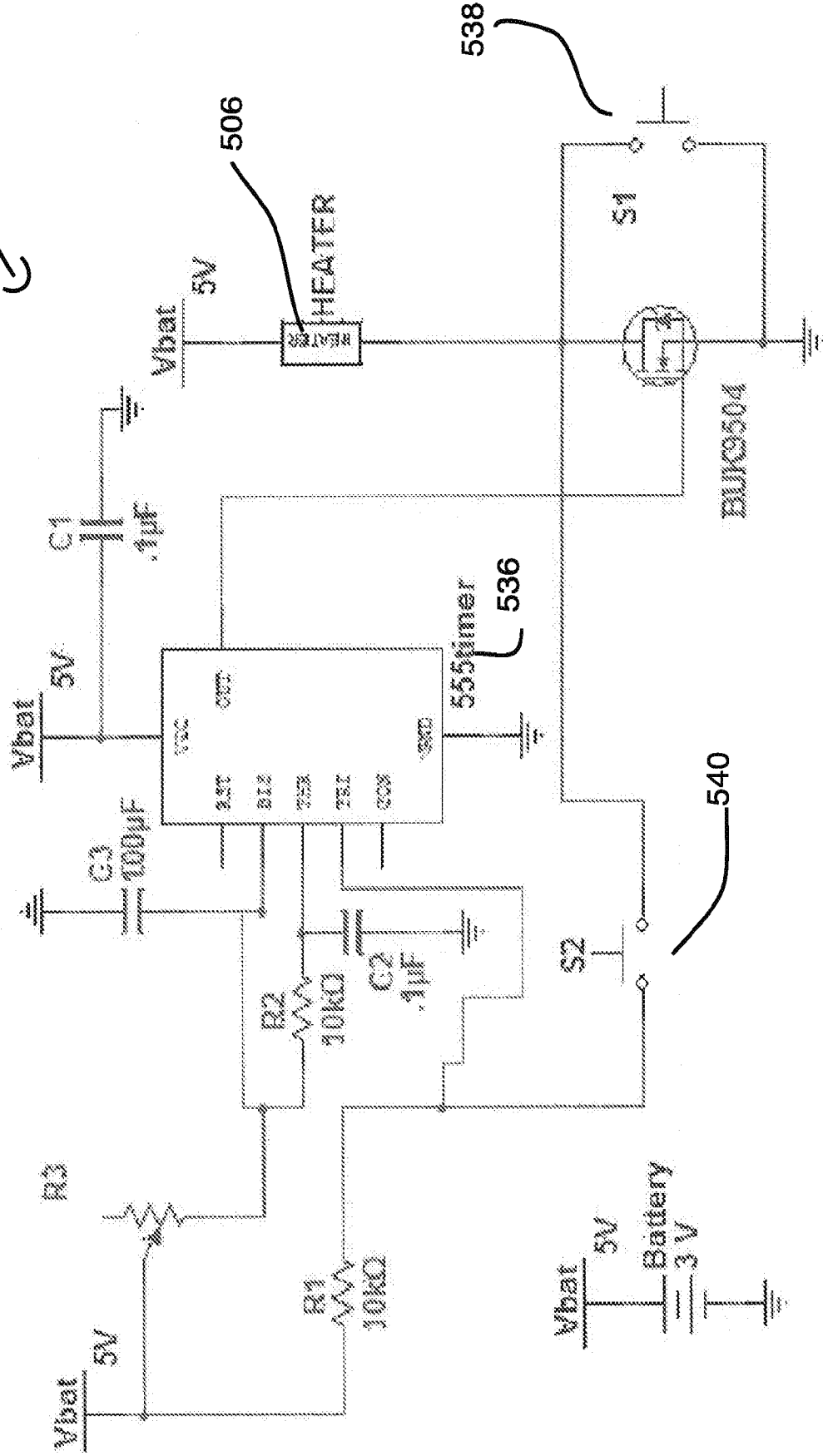

Fig. 35

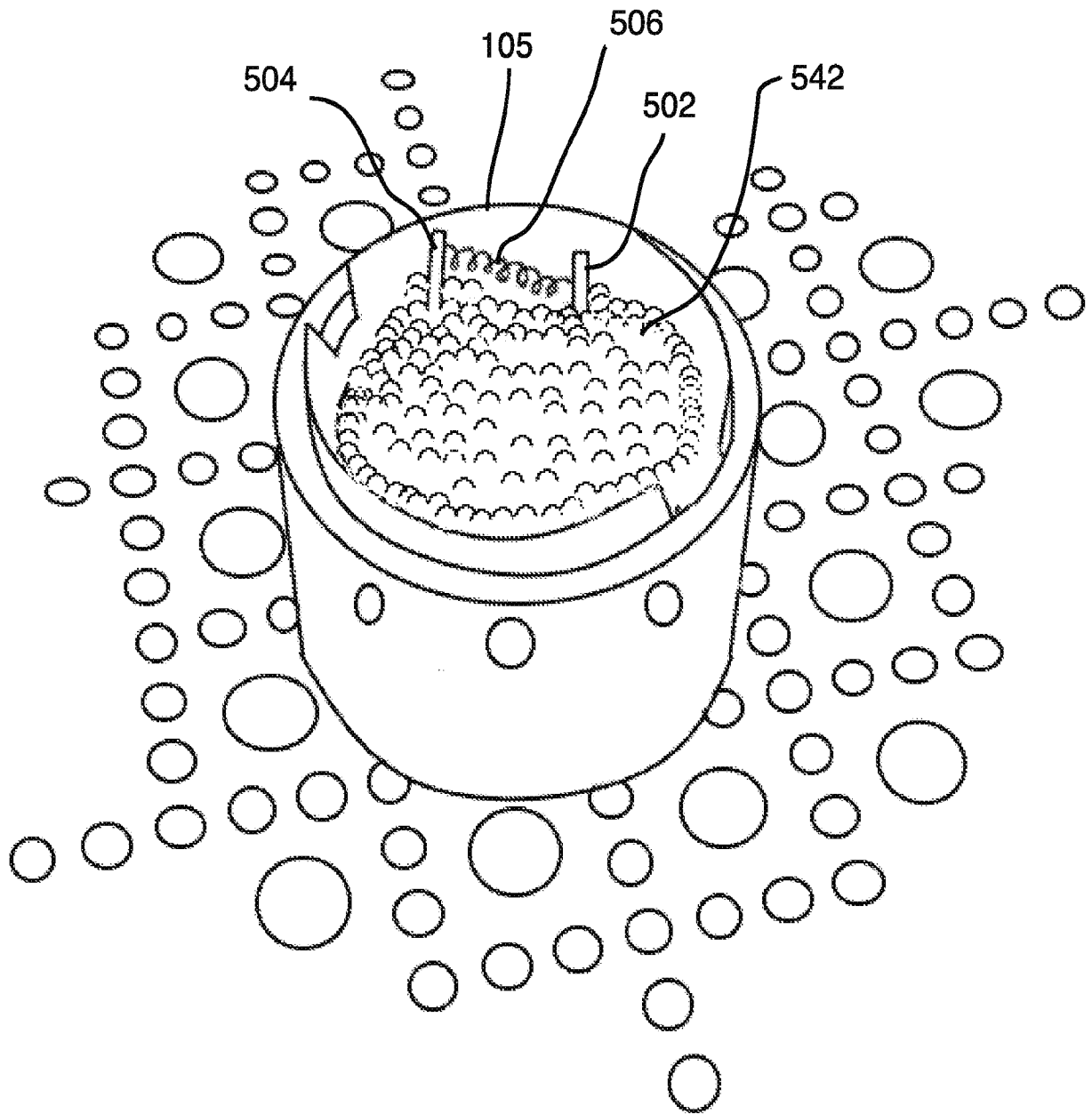

Fig. 36

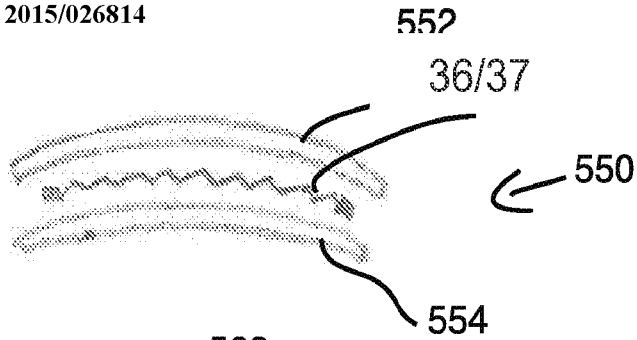

Fig. 37

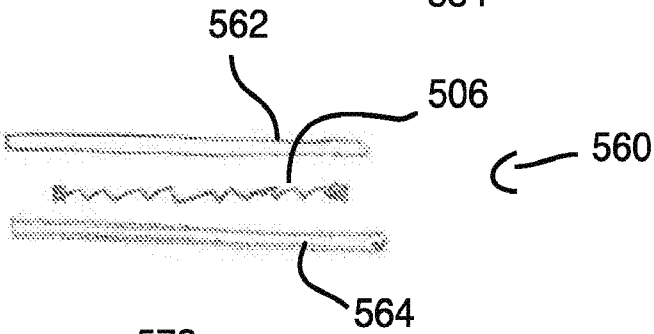

Fig. 38

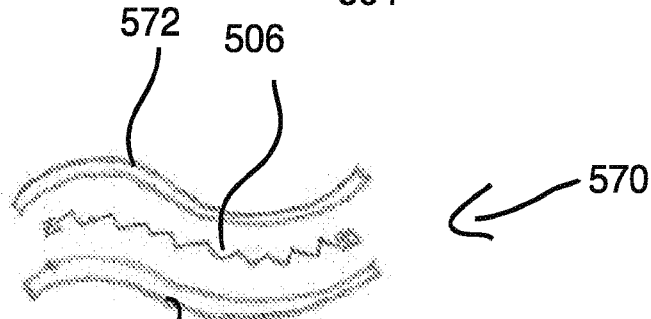

Fig. 39

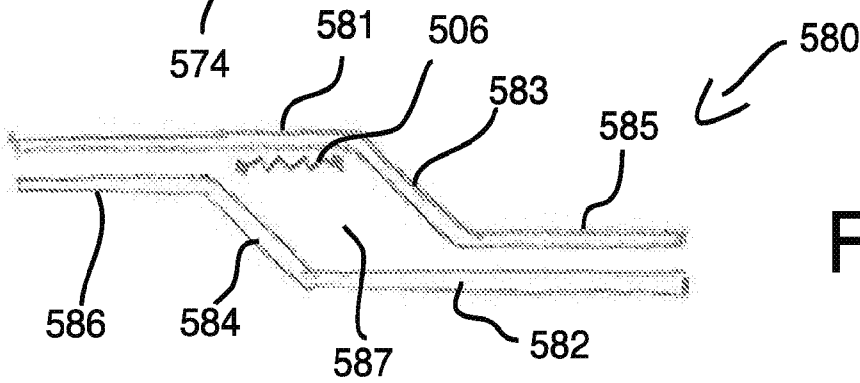

Fig. 40

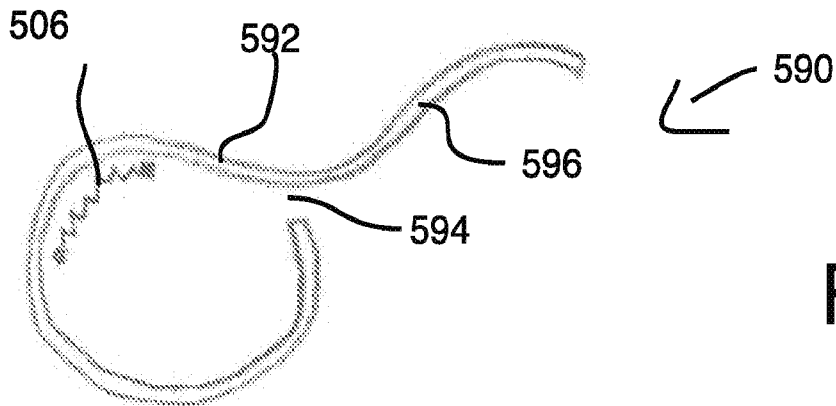

Fig. 41

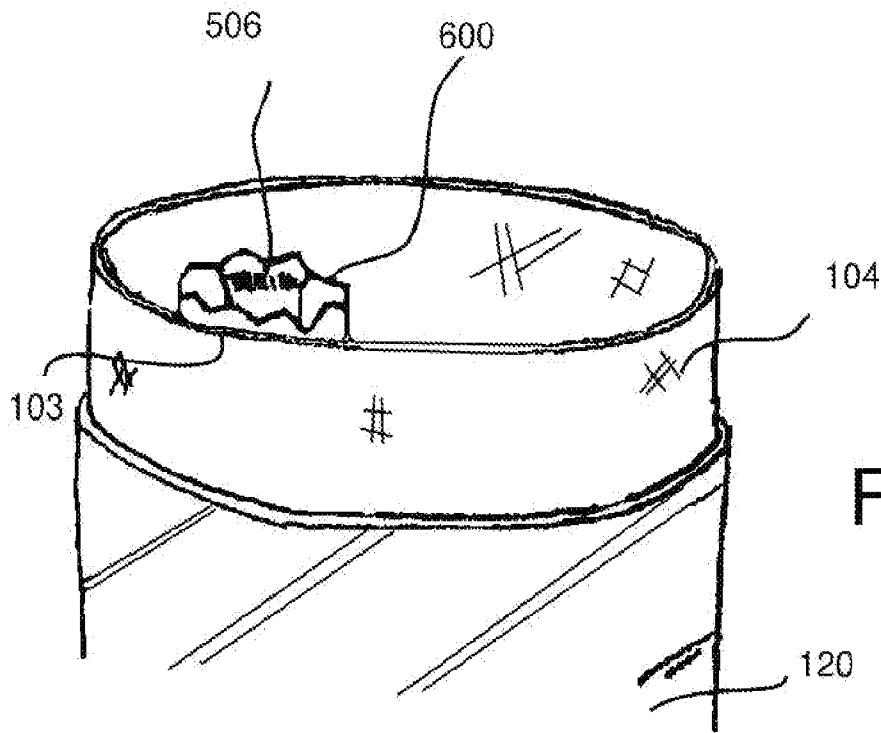

Fig. 42

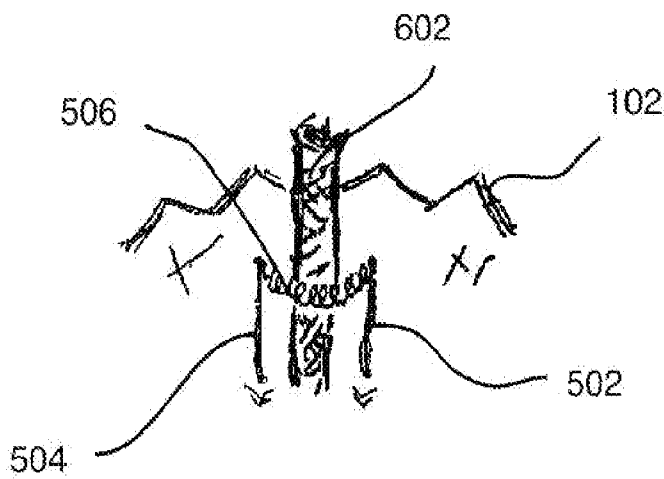

Fig. 43

<b>A. CLASSIFICATION OF SUBJECT MATTER</b> IPC(8) - F23D 3/08, 3/33, 7/00 (2014.01) CPC - F23D 3/08, 3/33, 7/00 According to International Patent Classification (IPC) or to both national classification and IPC		
<b>B. FIELDS SEARCHED</b> Minimum documentation searched (classification system followed by classification symbols) IPC(8): F23D 3/08, 3/33, 7/00, 3/40, 3/16, 3/02, 5/04 (2014.01) CPC: F23D 3/08, 3/33, 7/00; USPC: 431/333, 2, 326, 330, 353 Documentation searched other than minimum documentation to the extent that such documents are included in the fields searched Electronic data base consulted during the international search (name of data base and, where practicable, search terms used) MicroPatent (US-G, US-A, EP-A, EP-B, WO, JP-bib, DE-C,B, DE-A, DE-T, DE-U, GB-A, FR-A); ProQuest Patent; Google Patent; Google; Google Scholar; ProQuest; wax, paraffin, burner, wick, bridge, span, arch, link, melt, reservoir, chamber, core, vapor, ignition		
<b>C. DOCUMENTS CONSIDERED TO BE RELEVANT</b>		
Category*	Citation of document, with indication, where appropriate, of the relevant passages	Relevant to claim No.
A	US 2013/0115565 A1 (MASTERSON, D et al.) 09 May 2013; figures 1, 5, 6; paragraphs [0018]-[0022], [0028]-[0034]	1-34
A	US 1,957,014 A (HUMPOLETZ, K) 01 May 1934; figures 1-2; page 1, lines 1-10, 38-53	1-34
A	US 601,128 A (DALLY, EJ) 22 March 1898; figures 1-2; page 1, lines 59-90	1-34
A	GB 915,524 A (DON OIL BURNERS LIMITED) 16 January 1963; figures 1-2; page 1, lines 80-90; page 2, lines 7-34	1-34
P,&	US 2014/0127631 A1 (MASTERSON ENTERPRISES, INC.) 15 May 2014; entire document	1-34
P,&	US 2014/0134546 A1 (MASTERSON ENTERPRISES, INC.) 08 May 2014; entire document	1-34
P,&	US 2013/0344449 A1 (MASTERSON ENTERPRISES, INC.) 26 December 2013; entire document	1-34
<input type="checkbox"/> Further documents are listed in the continuation of Box C. <input type="checkbox"/>		
* Special categories of cited documents: "A" document defining the general state of the art which is not considered to be of particular relevance "E" earlier application or patent but published on or after the international filing date "L" document which may throw doubts on priority claim(s) or which is cited to establish the publication date of another citation or other special reason (as specified) "O" document referring to an oral disclosure, use, exhibition or other means "P" document published prior to the international filing date but later than the priority date claimed "T" later document published after the international filing date or priority date and not in conflict with the application but cited to understand the principle or theory underlying the invention "X" document of particular relevance; the claimed invention cannot be considered novel or cannot be considered to involve an inventive step when the document is taken alone "Y" document of particular relevance; the claimed invention cannot be considered to involve an inventive step when the document is combined with one or more other such documents, such combination being obvious to a person skilled in the art "&" document member of the same patent family		
Date of the actual completion of the international search 31 October 2014 (31.10.2014)		Date of mailing of the international search report 22 JAN 2015
Name and mailing address of the ISA/US Mail Stop PCT, Attn: ISA/US, Commissioner for Patents P.O. Box 1450, Alexandria, Virginia 22313-1450 Facsimile No. 571-273-3201		Authorized officer: Shane Thomas PCT Helpdesk: 571-272-4300 PCT OSP: 571-272-7774

-\*\*\*-Continued from Box No. III: Observations where unity of invention is lacking-\*\*\*-

The inventions listed as Groups I-II do not relate to a single general inventive concept under PCT Rule 13.1 because, under PCT Rule 13.2, they lack the same or corresponding special technical features for the following reasons: the special technical features of Group I include wax burning system comprising, a wick comprising a perimeter wall, a hollow core, and a bridge; the bridge has a first end and a second end, the first end joins with a first portion of the perimeter wall, the second end joins with a second portion of the perimeter wall, the bridge extends across the hollow core between the first and second portion of the perimeter wall; the hollow core is sized to stage vapor phase fuel below the flame adjacent the upper exit opening to create a partially oxygen deprived condition at a flame on the wick, which are not present in Group II; the special technical features of Group II include an electronic ignition system, comprising a power source, a filament, and a filament support, the filament is attached to the filament support, the filament support positions the filament adjacent the wick, the filament is configured to receive power from the power source and to generate heat, which are not present in Group I.

The common technical features of Groups I-II are a wax burning system comprising: a melted wax reservoir; a melting grate configured to receive a solid wax, the melting grate located above at least a portion of the melted wax reservoir so that wax melted on the melting grate can be received into the melted wax reservoir; a wick comprising: a hollow core, and an upper exit opening in communication with the hollow core; the hollow core forms a burn chamber extending above the melting grate; and a method of operating a wax burning system, comprising the steps of: locating a solid fuel on a melting grate adjacent to a wick, the solid fuel having a priming section; positioning the priming section adjacent the wick; heating at least a portion of the priming section with an ignition source adjacent the wick so that a portion of the priming section melts and falls; and igniting, with heat from the filament, the wick when the wick comprises a sufficient amount of fuel to support a flame.

These common technical features are disclosed by US 2013/0115565 A1 to Masterson, et al. (hereinafter 'Masterson'). Masterson discloses a wax burning system (a solid fuel burning apparatus using wax as a fuel); title; paragraph [0008] comprising: a melted wax reservoir (bowl 8 (reservoir) is deep and wide enough to hold adequate melted wax fuel for the system to use; figure 1; paragraph [0031]); a melting grate configured to receive a solid wax (perforated melting grate 5; figures 1, 5, 6; paragraphs [0028]-[0029]), the melting grate located above at least a portion of the melted wax reservoir so that wax melted on the melting grate can be received into the melted wax reservoir (perforated melting grate 5 transfers heat from the burning fuel in wick 1 into the bottom of solid wax fuel refill 7 that is placed on the melting grate, to melt the wax and allow it to flow through the grate and be contained in the bowl 8; figures 1, 5, 6; paragraphs [0028]-[0029]); a wick comprising: a hollow core, and an upper exit opening in communication with the hollow core (hollow wick 1 includes a hollow core where the top of the wick is open for forming a flame; figure 1; paragraphs [0018]-[0019]); the hollow core forms a burn chamber extending above the melting grate (when lit, the space within the hollow core wick above the melting grate 5 contains vapor phase wax fuel which manages the fuel reaction to complete combustion; figure 1; paragraph [0018]); and a method of operating a wax burning system, comprising the steps of: locating a solid fuel on a melting grate adjacent to a wick, the solid fuel having a priming section (the solid fuel refill 7 is placed on the melting grate near the wick 1, and also has a priming section 9; figures 1, 6; paragraph [0034]); positioning the priming section adjacent the wick (the priming section is just above the hollow wick 1; figure 6); heating at least a portion of the priming section with an ignition source adjacent the wick so that a portion of the priming section melts and falls (the priming section is melted by the heat of a flame from a match or lighter so that it flows down onto the wick 1; paragraph [0034]); igniting, with heat from the filament, the wick when the wick comprises a sufficient amount of fuel to support a flame (the priming section contains enough mass to allow the melted wax to heat to ignition after a short period; paragraph [0034]).

Since the common technical features are previously disclosed by Masterson, these common features are not special and so Groups I-II lack unity.

**Box No. II Observations where certain claims were found unsearchable (Continuation of item 2 of first sheet)**

This international search report has not been established in respect of certain claims under Article 17(2)(a) for the following reasons:

1.  Claims Nos.:  
because they relate to subject matter not required to be searched by this Authority, namely:
  
2.  Claims Nos.:  
because they relate to parts of the international application that do not comply with the prescribed requirements to such an extent that no meaningful international search can be carried out, specifically:
  
3.  Claims Nos.:  
because they are dependent claims and are not drafted in accordance with the second and third sentences of Rule 6.4(a).

**Box No. III Observations where unity of invention is lacking (Continuation of item 3 of first sheet)**

This International Searching Authority found multiple inventions in this international application, as follows:

This application contains the following inventions or groups of inventions which are not so linked as to form a single general inventive concept under PCT Rule 13.1. In order for all inventions to be examined, the appropriate additional examination fees must be paid.

Group I: Claims 1-34 are directed toward a wax burning system that includes a bridge, and a method of operation.

Group II: Claims 35-56 are directed toward a wax burning system that includes an electronic ignition system, and a method of operation.

\*\*\*-Continued Within the Next Supplemental Box-\*\*\*

1.  As all required additional search fees were timely paid by the applicant, this international search report covers all searchable claims.
2.  As all searchable claims could be searched without effort justifying additional fees, this Authority did not invite payment of additional fees.
3.  As only some of the required additional search fees were timely paid by the applicant, this international search report covers only those claims for which fees were paid, specifically claims Nos.:
4.  No required additional search fees were timely paid by the applicant. Consequently, this international search report is restricted to the invention first mentioned in the claims; it is covered by claims Nos.:

1-34

**Remark on Protest**

- The additional search fees were accompanied by the applicant's protest and, where applicable, the payment of a protest fee.
- The additional search fees were accompanied by the applicant's protest but the applicable protest fee was not paid within the time limit specified in the invitation.
- No protest accompanied the payment of additional search fees.