

R. H. WELLES.
 LOCKING MECHANISM FOR LAMPS AND ANALOGOUS STRUCTURES.
 APPLICATION FILED DEC. 5, 1908.

961,706.

Patented June 14, 1910.

Fig. 1.

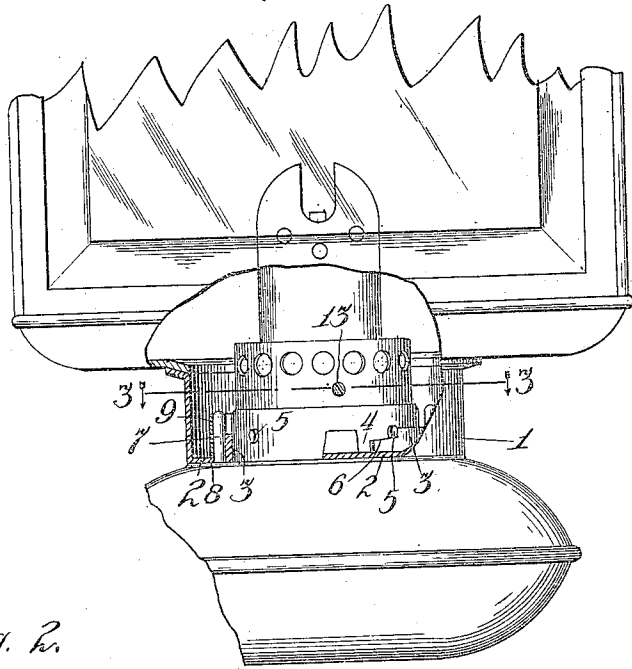

Fig. 2.

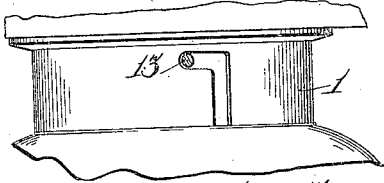

Fig. 3.

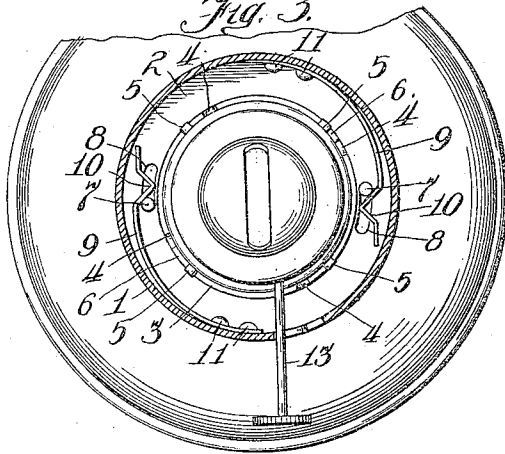
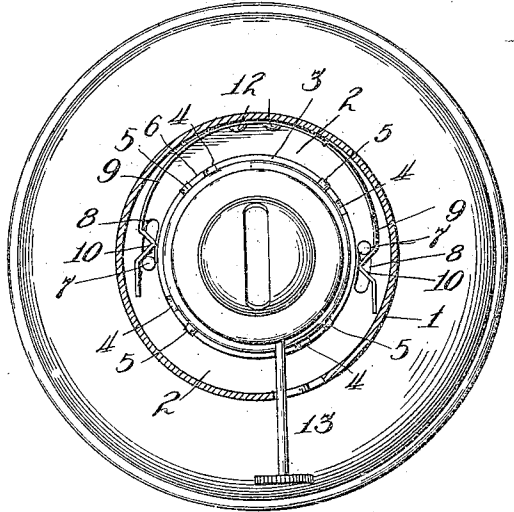

Fig. 4.



Witnesses
 Milton Lenoir
 Lois Force

Inventor,
 Richard H. Welles,
 By Albert N. Graves
 Attorney.

UNITED STATES PATENT OFFICE.

RICHARD H. WELLES, OF KENOSHA, WISCONSIN, ASSIGNOR TO THE BADGER BRASS MFG. CO., OF KENOSHA, WISCONSIN, A CORPORATION OF WISCONSIN.

LOCKING MECHANISM FOR LAMPS AND ANALOGOUS STRUCTURES.

961,706.

Specification of Letters Patent. Patented June 14, 1910.

Application filed December 5, 1908. Serial No. 466,072.

To all whom it may concern:

Be it known that I, RICHARD H. WELLES, a citizen of the United States, residing at Kenosha, in the county of Kenosha and State of Wisconsin, have invented certain new and useful Improvements in Locking Mechanism for Lamps and Analogous Structures, of which the following is a specification.

This invention relates to improvements in locking mechanisms for lamps and analogous structures.

Among the salient objects of the invention are to provide a locking mechanism of a bayonet-joint type in which spring pressure is relied upon to hold the parts locked together and this pressure tends constantly to force the parts into closer union and so serves to prevent rattling and danger of the parts becoming accidentally unlocked; to provide a mechanism characterized by extreme simplicity of construction and economy of manufacture; to provide a construction in which the acts of locking and unlocking are effected by simply applying rotative force or pressure to the parts, as distinguished from operating a push button, locking lever or the like; to provide a construction in which the support which sustains the weight of the lamp pot is, or may be, an integral part of the tubular waist of the headlight casing or upper lamp member which telescopes upon the upper part of the body of burner connected therewith; and in general to provide an improved construction of the character referred to.

To the above ends the invention consists in the matters hereinafter described and more particularly pointed out in the appended claims.

The invention will be readily understood from the following description, reference being had to the accompanying drawing in which:—

Figure 1 is a fragmentary view of the lower portion of an ordinary vehicle lamp embodying my invention, parts being broken away to reduce the figure and other parts broken out to expose internal parts. Fig. 2 is a side elevation of the waist portion of the lamp, the wick shaft being shown in section. Fig. 3 is a sectional view taken on line 3—3 of Fig. 1 and looking downwardly. Fig. 4 is a view similar to Fig. 3 showing a slightly modified construction.

Referring to the drawing, 1 designates the tubular waist portion of the upper lamp body or headlight casing, which at its lower end is turned at right angles inwardly to form a base flange 2 and at the inner edge of this flange is returned upwardly to form an upstanding flange 3. The upstanding flange is slotted through vertically at a plurality of points, as indicated at 4, to admit corresponding supporting studs 5 mounted upon, and projecting radially from, the base portion of the neck of the pot body. The upper edge of the flange 3 is cut away to produce inclined cam surfaces 6 extending from the upper end of each slot 4 circumferentially, all in the same direction; the length and inclination of these cam surfaces being such as to insure bringing the body of the pot into engagement with the lower end of the waist 1 before the studs 5, their rotative movement, reach the ends of the cam inclines.

The locking mechanism is functionally independent of the supporting mechanism described. Describing said locking mechanism, the top side of the pot is provided at one or more points radially inside of the tubular waist and in register with the base flange 2, with one or more straight upstanding studs (there being two shown) 7, and said base flange is provided with corresponding arc-shaped slots 8 adapted to receive these studs. The length of these slots is ample to accommodate the full rotative movement of the lamp pot relatively to the body.

Upon the inside of the waist member 1 is secured a spring 9 for each stud, each spring being provided near its free end with a V-shaped cam projection 10, which normally projects into the rotative path of movement of the corresponding stud. The points or apexes of the cam projections 10 are located approximately mid-length of the slots 8 and overlie the latter, so that the studs 7 wipe past them and force back the springs both in locking and unlocking the mechanism. It will be obvious therefore that as soon as the studs have passed the points of the cam projections in moving in either direction, the springs act cam fashion to aid in effecting such rotative movement, from which it follows that when locked the springs tend constantly to force the studs 5 up the cam inclines 6 and so hold

the pot in firm bearing with the lower end of the waist.

In the preferred construction, the two springs are made from a single piece of spring metal secured mid-length to the interior of the waist, as indicated at 12 in Fig. 4, while in Fig. 3 each spring is separately made and secured as indicated at 11.

The wick shaft 13 is shown as arranged to enter the waist through an inverted L-shaped slot, as is common in lamp structures.

From the foregoing it will be understood that I fully accomplish the several objects of the invention hereinbefore stated and provide a reliable locking mechanism, which may be manipulated with the utmost ease and convenience and in the dark practically as well as in daylight. In this connection it will be noted that the supporting studs 5 are so located that they prevent entering of the parts except in that position in which both sets of studs are in proper register with their respective slots and with the studs 7 in proper relation to the springs.

It will be obvious that the invention may be otherwise embodied without departing from the spirit of the invention.

I claim as my invention:

1. A locking mechanism comprising inter-fitting locking parts movable into and out of locking relation by relative rotative movement, and a spring mounted on one of said parts, moving radially relative thereto, and frictionally engaging the other of said parts when in locked position, to impel further rotative movement thereof in the locking direction.

2. In combination, upper and lower telescoping lamp members radially disposed horizontally extending studs on one member and cooperative cam inclines on the other, said parts being constructed to pass into and out of locking engagement by relative rotation, a spring carried by one of said parts and acting on the other to efficiently impel the supporting studs up the cam incline.

3. In combination an upper lamp member provided with a tubular waist and a base

flange, cam-inclines carried by said flange, a lower lamp member provided with radially disposed supporting studs adapted to cooperate with said cam inclines, and a spring acting on said parts to impel the supporting studs up said inclines and hold them in locking position.

4. In combination an upper lamp member provided with a tubular waist and a base flange, cam-inclines carried by said flange, a lower lamp member provided with radially disposed supporting studs adapted to cooperate with said cam inclines, an upright stud rigid with said lower lamp member and a spring carried by the upper member and cooperating with said upright stud to impel axial rotation of the lower member.

5. In combination an upper lamp member provided with a tubular waist, a base flange within said waist, a series of up-standing circumferentially extending cam-inclines carried by the base flange, a lower lamp member provided with a series of radial supporting studs, adapted to said cam-inclines, an upstanding stud rigid with said lower member and a spring mounted in said waist, arranged to flex radially and having a cam projection adapted to act on said upstanding stud to impel rotation of the member carrying said stud.

6. In combination an upper lamp member provided with a tubular waist, a base flange within said waist, a series of upstanding circumferentially extending cam-inclines carried by the base flange, a lower lamp member provided with a series of radial supporting studs, adapted to said cam-inclines, an upstanding stud rigid with said lower member, and a spring mounted in said waist, arranged to flex radially, and having a V-shaped cam-projection, each incline of which projection acts upon said upstanding stud to impel rotation of the lower member toward or from locked position, dependent upon which incline is acting.

RICHARD H. WELLES.

Witnesses:

LOIS FORCE,
F. L. BELKNAP.