

(19) World Intellectual Property Organization
International Bureau



(43) International Publication Date
15 January 2009 (15.01.2009)

PCT

(10) International Publication Number
WO 2009/007287 A1

(51) International Patent Classification:

A61M 5/158 (2006.01) A61B 5/15 (2006.01)
A61M 5/32 (2006.01)

(21) International Application Number:

PCT/EP2008/058512

(22) International Filing Date: 2 July 2008 (02.07.2008)

(25) Filing Language: English

(26) Publication Language: English

(30) Priority Data:

60/959,134 10 July 2007 (10.07.2007) US
PA 2007 01020 10 July 2007 (10.07.2007) DK

(71) Applicant (for all designated States except US): UN-
OMEDICAL A/S [DK/DK]; Birkerød Kongevej 2,
DK-3460 Birkerød (DK).

(72) Inventor; and

(75) Inventor/Applicant (for US only): NIELSEN, Jens, Ege-
bjerg [DK/DK]; Englerupvej 86, DK-4100 Ringsted (DK).

(74) Agent: ZACCO DENMARK A/S; Hans Bekkevolds Allé
7, DK-2900 Hellerup (DK).

(81) Designated States (unless otherwise indicated, for every
kind of national protection available): AE, AG, AL, AM,
AO, AT, AU, AZ, BA, BB, BG, BH, BR, BW, BY, BZ, CA,
CH, CN, CO, CR, CU, CZ, DE, DK, DM, DO, DZ, EC, EE,
EG, ES, FI, GB, GD, GE, GH, GM, GT, HN, HR, HU, ID,
IL, IN, IS, JP, KE, KG, KM, KN, KP, KR, KZ, LA, LC,
LK, LR, LS, LT, LU, LY, MA, MD, ME, MG, MK, MN,
MW, MX, MY, MZ, NA, NG, NI, NO, NZ, OM, PG, PH,
PL, PT, RO, RS, RU, SC, SD, SE, SG, SK, SL, SM, SV,
SY, TJ, TM, TN, TR, TT, TZ, UA, UG, US, UZ, VC, VN,
ZA, ZM, ZW.

(84) Designated States (unless otherwise indicated, for every
kind of regional protection available): ARIPO (BW, GH,
GM, KE, LS, MW, MZ, NA, SD, SL, SZ, TZ, UG, ZM,
ZW), Eurasian (AM, AZ, BY, KG, KZ, MD, RU, TJ, TM),
European (AT, BE, BG, CH, CY, CZ, DE, DK, EE, ES, FI,
FR, GB, GR, HR, HU, IE, IS, IT, LT, LU, LV, MC, MT, NL,
NO, PL, PT, RO, SE, SI, SK, TR), OAPI (BF, BJ, CF, CG,
CI, CM, GA, GN, GQ, GW, ML, MR, NE, SN, TD, TG).

[Continued on next page]

(54) Title: INSERTER HAVING TWO SPRINGS

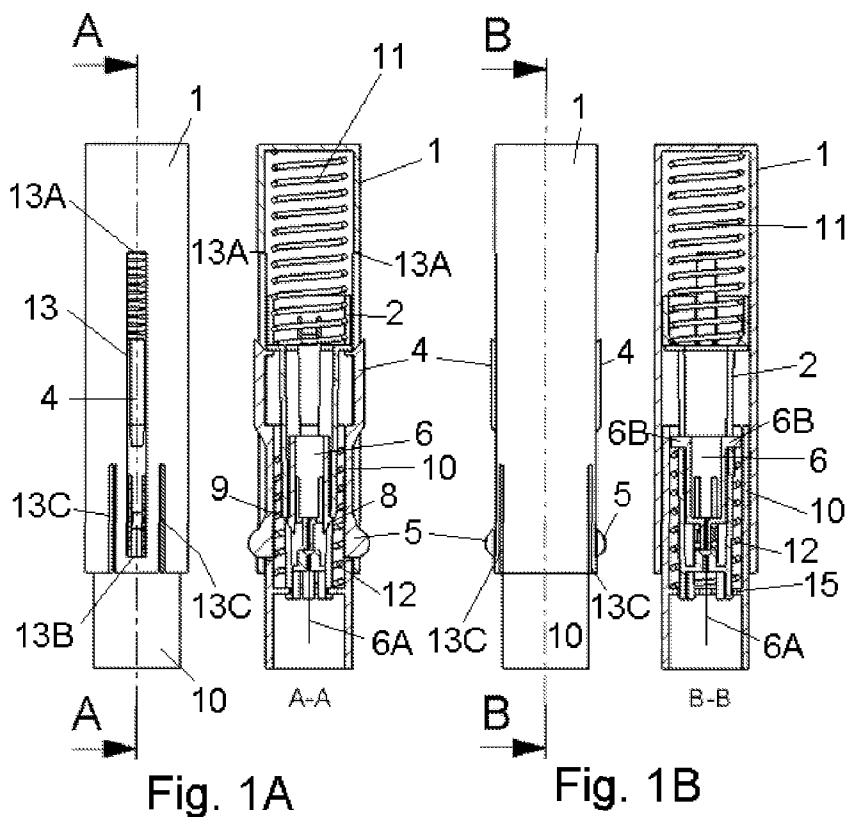

(57) Abstract: The invention relates to an inserter for a medical device e.g. an infusion set or the like for intermittent or continuous administration of a therapeutical substance, such as e.g. insulin. The inserter comprises a needle hub comprising an insertion needle and two elastic elements assuring automatic insertion and automatic retraction of the insertion needle. Activation of the first elastic element (11) cause a penetrating member (6A) to be inserted into the skin of a patient, and the second elastic element (12) cause the penetrating member (6A) to be retracted from the skin of the patient. The first elastic element (11) is in an unloaded state before activation and upon activation the first elastic element (11) energizes the second elastic element (12).

WO 2009/007287 A1



Published:

— *with international search report*

Inserter having two springs

Technical field

The invention relates to an inserter for a medical device e.g. an infusion set
5 or the like for intermittent or continuous administration of a therapeutical
substance, such as e.g. insulin. The inserter comprises a needle hub
comprising an insertion needle and two elastic elements assuring automatic
insertion and automatic retraction of the insertion needle.

10 Background of the invention

WO 2005/046780 (fig. 97 – 102) describes a device used for automatic
insertion of a cannula of an infusion device into the skin of a patient, and
afterwards automatic retraction of the insertion needle. The insertion device
has the form of an oblong cylinder which is open in one end (1984) and
15 provided with means for activation at the other end (1952). When the infusion
set has been loaded onto the needle (1968) the lock member (1962) is
moved in direction of the end provided with means for activation by the
patient using projections (1974) until barbs (1956) of the lock member (1962)
engage an outer surface of the housing (page 26, l. 24-27). The projections
20 (1974) are accessible through a slot (1976) of the housing. Then the open
end (1984) is placed against the skin of the patient and the means for
activation (1952) is activated. When activated shoulders (1954) on the means
for activation engage, the barbs (1956) are pushed toward each other in
order to disengage the barbs from the housing. When the barbs are clear of
25 the housing the lock member, the needle hub, the retainer body and the
associated infusion device are moved by a first spring in direction of the open
end (1984). The inserter device moves the infusion device towards the skin
of the patient thereby inserting the needle and the cannula of the infusion
device. As the cannula is fully inserted, barbs (1964) of the needle hub
30 (1965) engage ramped surfaces (1972) of the sleeve (1982), causing the
barbs (1964) to be forced toward one another. When the barbs (1964) have

been forced sufficiently inwardly to clear ends (1988) of the main body (1980), the second spring (1966) then moves the needle hub (1965) in the direction of the activation means (1952). Thus the needle is removed from the infusion device leaving the infusion device in place on the skin while the
5 retainer body remains in a position adjacent the open end of the sleeve so that once the insertion device is removed from the skin of the patient, the retainer body protects the patient from further contact with the needle.

This insertion device is rather complex and the length of the device is defined
10 by the individual units forming the functional parts of the device as these units have to be placed more or less end to end. A feature illustrating the complexity of the unit is the fact that the two springs respectively biases the housing from the lock member and the retainer body from the needle hub while a main body is placed between the two spring systems to transfer the
15 force from the first spring to the second spring.

According to the present invention the two spring units work directly together, as the first spring unit directly affects the movement of the carrier body while the second spring system is directly affected by the movement of the carrier
20 body. That the spring units directly affect or is directly affected by the carrier body means that the spring units are connected to the carrier body directly or through a part which transfers the power either unchanged or under controlled modifications.

25 **Description of invention**

The object of the invention is to provide a simple, non-expensive inserter for an infusion device which inserter would be easy and safe for the user to handle during use and safe to dispose of after use.

30 The invention concerns an inserter for a medical device comprising two elastic elements where activation of the first elastic element cause a

penetrating member to be inserted sub- or transcutaneously into the skin of a patient, and the second elastic element cause the penetrating member to be retracted from the skin of the patient wherein the first elastic element is in an unloaded state before activation and upon activation the first elastic element energizes the second elastic element. That the first elastic element is in an unloaded state means that it is un-biased or slightly biased, and only upon activation the first elastic element will be loaded. This assures that the first elastic element does not decay during storing before use.

10 According to this invention the first elastic element has two functions, it injects the penetrating member together with the medical device and it energizes the second elastic element thereby make it possible for the second elastic element to cause a retraction of the penetrating member and leaving the medical device on the patients skin.

15 According to one embodiment of the invention the first elastic element is a spring having a spring constant k_1 .

20 According to the above embodiment of the invention or another embodiment the second elastic element is a spring having a spring constant k_2 .

25 According to one embodiment of the invention the spring constant k_1 of the first elastic element is larger than the spring constant k_2 of the second elastic element, normally the spring constant $k_1 \geq 2 \times k_2$.

30 According to one embodiment the spring constant $k_1 \geq 0.2$ and the spring constant $k_2 \geq 0.09$.

According to one embodiment the first elastic element and/or the second elastic element are/is a helical spring.

According to one embodiment of the invention the inserter comprises

- a stationary part (10) being stationary in relation to the patient during insertion and resting against the patients skin,

- activation means (1),

5 - a carrier body (2) which carrier body (2) has a forward and a retracted position relative to the stationary part (10) and

- a needle hub (6) connected with a penetrating member (6A),

- first locking means (4) locking the carrier body (2) in a retracted position,

- first release means (13A) unlocking the carrier body (2) from a retracted

10 position,

- second locking means (8, 9) locking the needle hub (6) in a forward position relative to the carrier body (2),

- second release means (15A) unlocking the needle hub (6) from the forward position,

15 wherein the first elastic element (11) apply force to a surface of the house (1) and to a surface of the carrier body (2) and the second elastic element (12) apply force to a surface of the needle hub (6) and to a surface of the stationary part (10).

20 According to such an embodiment the house can be the activation means and inside the house the carrier body moves from a retracted to a forward position when the first elastic element is activated.

25 According to such an embodiment the second release means automatically releases the needle hub from the carrier body when it passes a certain position e.g. the release means can be part of the stationary part.

30 According to this embodiment a first integrated part comprising the first elastic element can be separated from a second integrated part comprising the second elastic element and the penetrating needle e.g. the first integrated part is reusable and the second integrated part is disposable.

The invention also relates to use of an inserter as described above e.g. for sub- or transcutaneously positioning of a unit for metering a substance e.g. the glucose content of the blood and/or sub- or transcutaneously positioning of an infusion part of an infusion set for delivering of a drug e.g. insulin to the patient and/or sub- or transcutaneously positioning of a gateway for replacing multiple injections.

Description of the drawings

10 The invention is explained in greater detail below with reference to the accompanying drawings wherein a preferred embodiment of the invention is shown.

Fig. 1A and 1B show a side view of the embodiment where the carrier body and the medical device are in a retracted position before insertion, fig. 15 1C shows a spatial side view of the same position;

Fig. 2A and 2B show a side view of the embodiment where the carrier body and the medical device are in a retracted position before insertion, fig. 2C shows a spatial side view of the same position;

Fig. 3A and 3B show a side view of the embodiment where the carrier body and the medical device are in a fully forward position, fig. 3C shows a 20 spatial side view of the same position;

Fig. 4A and 4B show a side view of the embodiment where the carrier body is in a forward position and the medical device is in a retracted position; fig. 4C shows a spatial side view of the same position;

25 Fig. 5A and 5B show a side view of the embodiment where the carrier body and the medical device are in a retracted position after insertion, fig. 5C shows a spatial side view of the same position;

Fig. 6 shows a top view of a medical device which can be used with the inserter device.

The embodiment of the inserter device of fig. 1A, 1B and 1C is shown in a state before insertion of the medical device. The embodiment comprises a house 1, a carrier body 2, a stationary part 10 which is stationary in relation to the patient during use and a needle hub 6 provided with a penetrating member 6A. Further the inserter device comprises two elastic elements in the form of two spring units, an inserter spring 11 having a spring constant k_1 and a retraction spring 12 having a spring constant k_2 .

10 The inserter spring 11 applies pressure to the house and to the carrier body 2, i.e. when the inserter spring 11 is reduced in length it exercises a pressure upwards on the house 1 and downwards on the carrier body pushing the two parts away from each other. The retraction spring 12 applies pressure to the needle hub 6 and to the stationary part 10, i.e. when the retraction spring 12 is reduced in length it exercises a pressure upwards on the needle hub 6 and downwards on the stationary part 10 (upwards/downwards relate to the embodiments as shown in the figures).

20 The house 1 has a cylindrical body with a closed distal end and an open proximal end, and the house 1 is provided with two longitudinal openings 13 on opposite sides of the body of the house 1; the openings are limited towards the distal end by an edge 13A and towards the proximal end by and edge 13B. Further the house 1 is provided with four slots 13C, one on each side of each longitudinal opening 13, extending from the proximal edge of the house 1.

30 The stationary part 10 also has a cylindrical body which fits inside the body of the house 1. The stationary part 10 comprises a pair of oppositely positioned outward arms 4 placed at the distal end of the cylindrical body and means for releasing of a replaceable part of the inserter device in the form of a pair of inward arms 5 placed closer to the proximal end of the body of the stationary

part 10 than the outward arms 4. Also the stationary part 10 is provided with a protruding circular edge 15 having protruding parts 15A.

5 The lower or proximal side of the protruding parts on the arms 5 provides a stop for the relative movement between the stationary part 10 and the house 1, i.e. it is not possible to pull the stationary part 10 out of the house 1 when the oppositely placed arms 5 are in a relaxed position. When the arms 5 are pushed towards each other the arms 5 are in a tensioned position and it is possible to pull the stationary part 10 out of the house 1 and replace the
10 stationary part 10 with a new e.g. unused part or e.g. with a part having another function or having a different medical device attached. The slots 13C allow an increment of the diameter of the house 1 which increment makes it possible to remove the stationary part 10 from the shown embodiment of the house 1 without destroying the house 1. After use the carrier body 2 of the
15 embodiment shown in the figures will be stuck inside the stationary part 10, and therefore the carrier body 2 will be removed together with the stationary part 10.

20 The carrier body 2 also comprises a cylindrical body, where the distal end of the cylindrical body has an increased diameter compared to the proximal end of the cylindrical body. The distal part of the cylindrical part of the carrier body has a surface against which the inserter spring 11 rests, also the outward arms 4 of the stationary part 10 rest against a surface of the carrier body 2. The carrier body 2 is provided with two longitudinal openings 7 on
25 opposite positions on the proximal part of the cylindrical body which openings functions as guiding means for protruding parts 6B of the needle hub 6. The longitudinal openings assure that the needle hub 6 can only travel a certain distance corresponding to the openings 7 inside the carrier body 2. The carrier body 2 also is provided with a closed proximal exit having an opening
30 which is just large enough to allow the penetrating member to pass through. Such a nearly closed end prevents access to the contaminated penetrating

member after use. The embodiment shown in the figures also has two openings 7A perpendicular to the openings 7 and extending from the proximal end of the cylindrical body of the carrier body 2. The protruding parts 15A of the protruding circular edge 15 of the stationary part 10 extend
5 into these openings 7A and are guided along the openings 7A when the carrier body 2 moves in relation to the stationary part 10. The proximal end surface of the carrier body 2 touches the patient's skin when the carrier body 2 is in a most forward position relative to the stationary part 10. When the carrier body 2 is in a most retracted position relative to the stationary part 10
10 - which is the state shown in fig. 1A, 1B and 1C -, inward protruding parts of the outward arms 4 of the stationary part 10 rest against a surface of the distal part of the cylindrical body of the carrier body 2.

The needle hub 6 is before use placed inside the distal part of the cylindrical
15 body of the carrier body 2. The distal end of the needle hub 6 is provided with two protruding parts 6B which are placed on opposite positions on the cylindrical body of the needle hub 6 (shown in fig. 1B) and as mentioned above the longitudinal openings 7 assure that the needle hub 6 can only travel a certain distance inside the carrier body 2 corresponding to the length
20 of the openings 7. The needle hub also comprises pivotally mounted arms 8 having hooks which in the retracted position are in contact with proximal turned surfaces 9 of the carrier body 2. This proximal turned surface 9 is the distal edge of the opening 7A.

25 Fig. 2A, 2B and 2C show the inserter device in a state where the inserter spring 11 is compressed and therefore biased but before the carrier body 2 and the needle hub 6 is brought forward.

As indicated with arrows in fig. 2A the outward arms 4 of the stationary part
30 10 is affected by an outward pressure which pressure results from the contact between the outward arms 4 and the proximal edge 13A of the

opening 13. When the inclined surface of the outward arms 4 slides against the distal edge 13A of the opening 13 in the house 1 the contact causes the arms 4 to be moved away from each other. When the outward arms 4 of the stationary part 10 is freed from contact with the distal edge 13A of the opening 13, then the compressed inserter spring 11 will exercise a downward force on the carrier body 2 and on the needle hub 6 which at this point is locked to the carrier body 2.

The downward movement of the combined carrier body and needle hub 6 brings the inserter device to the state illustrated in fig. 3A, 3B and 3C.

Fig. 3A, 3B and 3C shows the needle hub 6 in a position where the penetrating member 6A is fully inserted in the patients skin. The retraction spring 12 has been compressed and thereby energized as the spring constant k_2 of the retraction spring 12 which pushes upward on the protruding parts 6B of the needle hub 6 is smaller than the spring constant k_1 of the inserter spring 11 which pushes downward on the carrier body 2. Normally the spring constant k_1 of the inserter spring 11 is equal to or larger than 0.25 N/mm and the spring constant k_2 of the retraction spring 12 is equal to or larger than 0.1 N/mm. After the distal part of the cylindrical body of the carrier body 2 has passed between the outward arms 4 of the stationary part 10, the outward arms 4 return to their position and the distal part of the carrier body 2 is now between the arms 4 instead of above the arms 4 as shown in fig. 2. The carrier body 2, the stationary part 10 and the house 1 are at this position all at a level where they touch the patients skin. The pivotally mounted arms 8 of the needle hub 6 which have an inclined surface have in this position been forced inwards by the protruding parts 15A of the protruding circular edge 15. The inward movement is a result of the stationary protruding parts 15A touching the pivotally mounted arms 8 when the arms 8 move downwards.

Fig. 4A, 4B and 4C shows the inserter device in a state where the needle hub 6 is in a position where the penetrating member 6A is fully retracted from the patients skin. The retraction spring 12 has pushed the needle hub 6 as far upwards and away from the patient as possible, the needle hub 6 can only
5 move to the upper end of the proximal part of the carrier body 2 as the protruding parts 6B of the needle hub 6 at this position will come into contact with a surface of the distal part of the carrier body 2.

Fig. 5A, 5B and 5C shows the inserter device in a state where the needle hub
10 6, the carrier body 2 and the stationary part 10 are positioned as in fig. 4, but in fig. 5 the user has released the pressure on the house 1 and therefore the house has jumped back into the same position as in fig. 1 where the inserter spring 11 is relaxed.

15 When using the inserter device a medical device, which is not shown on the drawings, is placed on or in connection with the penetrating member 6A either inside the stationary part 10 if e.g. the medical device has a diameter smaller than the inner circumference of the stationary part 10 or it is placed partly inside and partly around the proximal end of the stationary part 10 if
20 the diameter of the medical device is larger than the inner circumference of the stationary part 10.

Fig. 6 shows a top view of a medical device which can be used in the inserter device shown in fig. 1-5. The medical device is of the port type and therefore
25 only provides an access to the patients blood e.g. with a syringe without having to penetrate the patients skin again and again. The medical device comprises a mounting pad 20 having an adhesive surface which is normally covered by a protective release layer. The only parts of the release layer which are being visible on fig. 6 are the handle parts 25, which are used to
30 remove the release layer just before use. Further the medical device comprises a body 21 provided with tracks 22 for mounting of the stationary

device 10, tracks 23 for allowing entrance of the carrier body 2 and a through-going opening 24 for the penetrating member 6A of the needle hub 6. The shown embodiment has three partly circular tracks 22 which correspond to protruding end parts on the stationary part 10. A close fitting
5 between the tracks 22 and the protruding parts of the stationary part 10 will normally be enough to hold the medical device in position on the stationary part before insertion. The body 21 of the medical device is also provided with a circular track 23 which is able to receive the proximal end of the carrier body 2. When the carrier body 2 is moved forward towards the patients skin
10 the carrier body 2 enters the tracks 23, the tracks 23 do not need to have a close fit to the proximal end of the carrier body 2, the tracks 23 merely has to provide a guidance in order for the penetrating member 6A to enter at exactly the right position i.e. the through-going opening 24.

15 If the medical device is provided with a cannula extending from the proximal side of the device, the medical device has to be fastened to the inserter device before insertion in order to have the cannula mounted subcutaneously and in this case the medical device will either be mounted in such a way that the penetrating member 6A of the needle hub 6 is placed inside a soft
20 cannula when the inserter device and the medical device are delivered to the user, or the if the medical device is provided with a hard self-penetrating cannula then the medical device can be delivered to the user connected to the needle hub 6 or the user can unpack the sterile medical device and connect it to the needle hub 6.

25

If the medical device is not provided with a cannula, then the medical device can be fastened to the patients skin before insertion. The cannula will then - irrespective of whether this is a hard self-penetrating or a soft cannula - be provided together with the needle hub 6 e.g. as a separate cannula part (1b)
30 as shown in PCT application no. PCT/DK2006/000737.

If the medical device is provided with a soft cannula, the medical device will be delivered to the patient as an integrated part of the inserter device. When the inserter device has been unpacked and is ready for use the release layer is removed from the mounting pad 20 and then the medical device joint to the inserter device is placed against the skin of the patient. The user then activates the insertion procedure by pushing the house 1 of the inserter device towards the patients skin. This one push causes the needle hub and the hereto joint medical device and penetrating member 6A to be inserted subcutaneously and afterwards the penetrating member 6A is automatically being retracted and placed inside the carrier body 2. The user can then remove the inserter device from the medical device leaving the medical device fully functional on the patients skin.

The inserter might be constructed having a first integrated part comprising a group of elements which can be reused. This first integrated part will normally comprise the house 1 which then can be made more durable and be provided with a more luxurious and expensive look and details. Normally this first integrated part will also comprise the first elastic element 11 as this element could then be constructed in a more expensive quality. The first integrated part would be combined with a group of elements in the form of a second integrated part which part cannot be reused. The second integrated part would e.g. comprise the insertion needle and parts combined with the insertion needle e.g. the second elastic element.

The inserter can be used for sub- or transcutaneously positioning of a unit for metering a substance e.g. the glucose content of the blood and/or for sub- or transcutaneously positioning of an infusion part of an infusion set for delivering of a drug e.g. insulin to the patient and/or sub- or transcutaneously positioning of a gateway for replacing multiple injections, such a gate way is e.g. known from the international patent application PCT/DK2006/050005 and this gateway is incorporated in the present application by reference. The

inserter can also be used for inserting a cannula device as known from PCT/DK2006/00737 e.g. figures 32-36, such a cannula device is hereby incorporated in the present application by reference.

List of references:	
House	1
Carrier body	2
Outward arms of stationary part	4
Inward arms of stationary part	5
Needle hub	6
Penetrating member	6A
Protruding parts of needle hub	6B
Longitudinal opening in carrier body	7
Openings perpendicular to the openings 7 in the carrier body 2	7A
Pivotally mounted arms of needle hub	8
Proximal turned surface of carrier body	9
Stationary part	10
Inserter spring F1	11
Retraction spring F2	12
Longitudinal opening in house	13
Distal edge of opening in house	13A
Proximal edge of opening in house	13B
Slots in house	13C
Pivotally arms of needle hub	14
Protruding circular edge of stationary part	15
Protruding parts of protruding circular edge	15A
Mounting pad	20
Body of medical device	21
Tracks for stationary part in medical device	22
Opening in medical device for receiving carrier body	23
Through-going opening for penetrating member	24
Handle parts of release layer	25

Claims:

1. An inserter for a medical device comprising two elastic elements (11, 12) where activation of the first elastic element (11) cause a penetrating member (6A) to be inserted sub- or transcutaneously into the skin of a patient, and the
5 second elastic element (12) cause the penetrating member (6A) to be retracted from the skin of the patient **characterized in** that the first elastic element (11) is in an unloaded state before activation and upon activation the first elastic element (11) energizes the second elastic element (12).
- 10 2. An inserter for a medical device according to claim 1, wherein the first elastic element is a spring (11) having a spring constant k_1 .
3. An inserter for a medical device according to claim 1 or 2, wherein the second elastic element is a spring (12) having a spring constant k_2 .
- 15 4. An inserter for a medical device according to claim 1, wherein the spring constant k_1 of the first elastic element is larger than the spring constant k_2 of the second elastic element.
- 20 5. An inserter for a medical device according to claim 4, wherein the spring constant $k_1 \geq 2k_2$.
6. An inserter for a medical device according to claim 4, wherein the spring constant $k_1 \geq 0.2$ and the spring constant $k_2 \geq 0.09$.
- 25 7. An inserter for a medical device according to claim 1, wherein the first elastic element and/or the second elastic element are/is a helical spring.
8. An inserter for a medical device according to claim 1, comprising
30 - a stationary part (10) being stationary in relation to the patient during insertion and resting against the patients skin,

- activation means (1),
 - a carrier body (2) which carrier body (2) has a forward and a retracted position relative to the stationary part (10) and
 - a needle hub (6) connected with a penetrating member (6A),
 - 5 - first locking means (4) locking the carrier body (2) in a retracted position,
 - first release means (13A) unlocking the carrier body (2) from a retracted position,
 - second locking means (8, 9) locking the needle hub (6) in a forward position relative to the carrier body (2),
 - 10 - second release means (15A) unlocking the needle hub (6) from the forward position,
- wherein the first elastic element (11) apply force to a surface of the house (1) and to a surface of the carrier body (2) and the second elastic element (12) apply force to a surface of the needle hub (6) and a surface of the stationary
- 15 part (10).

9. An inserter for a medical device according to claim 8, wherein the house (1) is the activation means (1) and inside the house (1) the carrier body (2) moves from a retracted to a forward position when the first elastic element

20 (11) is activated.

10. An inserter for a medical device according to claim 8, wherein the second release means (15A) automatically releases the needle hub (6) from the carrier body (2) when it passes a certain position.

25

11. An inserter for a medical device according to claim 10, wherein the release means (15A) are part of the stationary part (10).

12. An inserter for a medical device according to claim 8, wherein a first

30 integrated part (1, 11) comprising the first elastic element (11) can be

separated from a second integrated part (2, 6, 10, 12) comprising the second elastic element (12) and the penetrating needle.

13. An inserter for a medical device according to claim 12, wherein the first
5 integrated part (1, 11) is reusable and the second integrated part (2, 6, 10, 12) is disposable.

14. Use of an inserter according to claim 1-13 for sub- or transcutaneously
10 positioning of a unit for metering a substance e.g. the glucose content of the blood and/or sub- or transcutaneously positioning of an infusion part of an infusion set for delivering of a drug e.g. insulin to the patient and/or sub- or transcutaneously positioning of a gateway for replacing multiple injections.

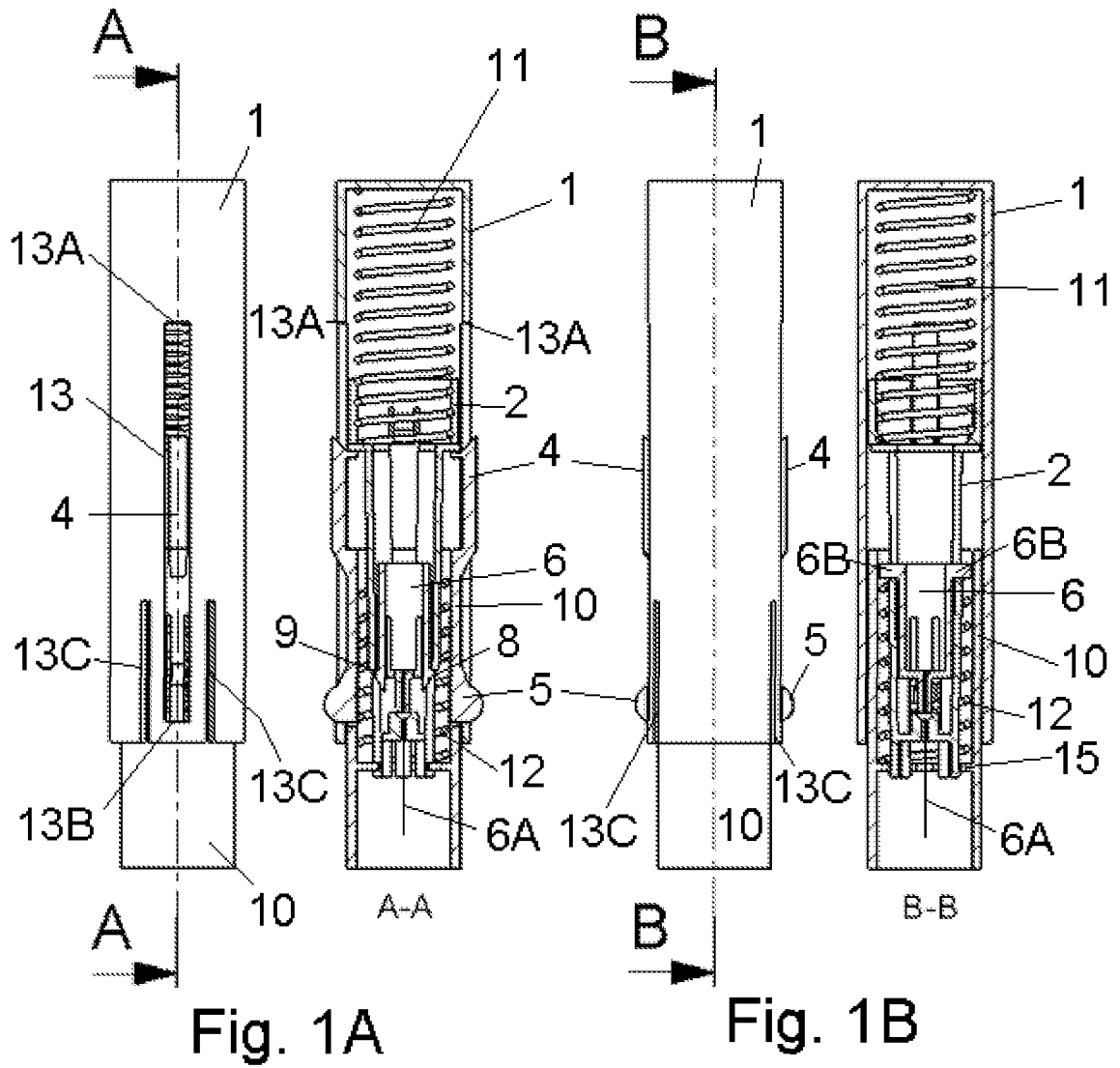

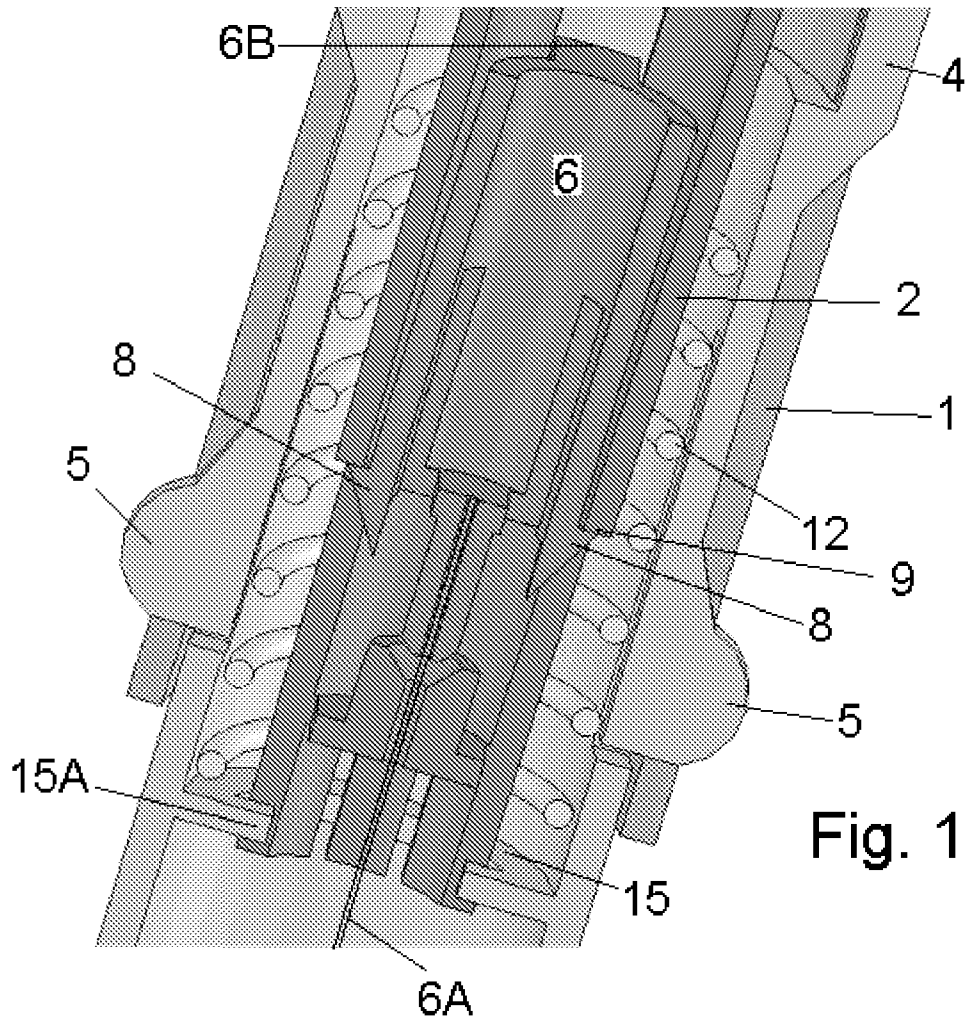

Fig. 1C

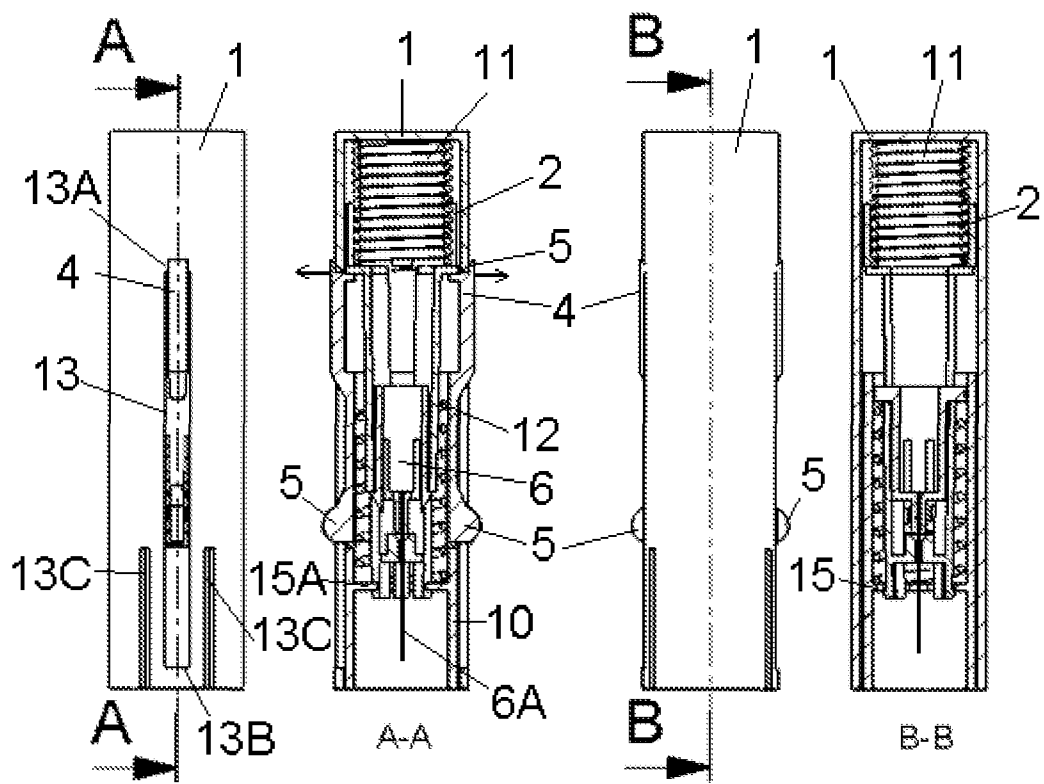

Fig. 2A

Fig. 2B

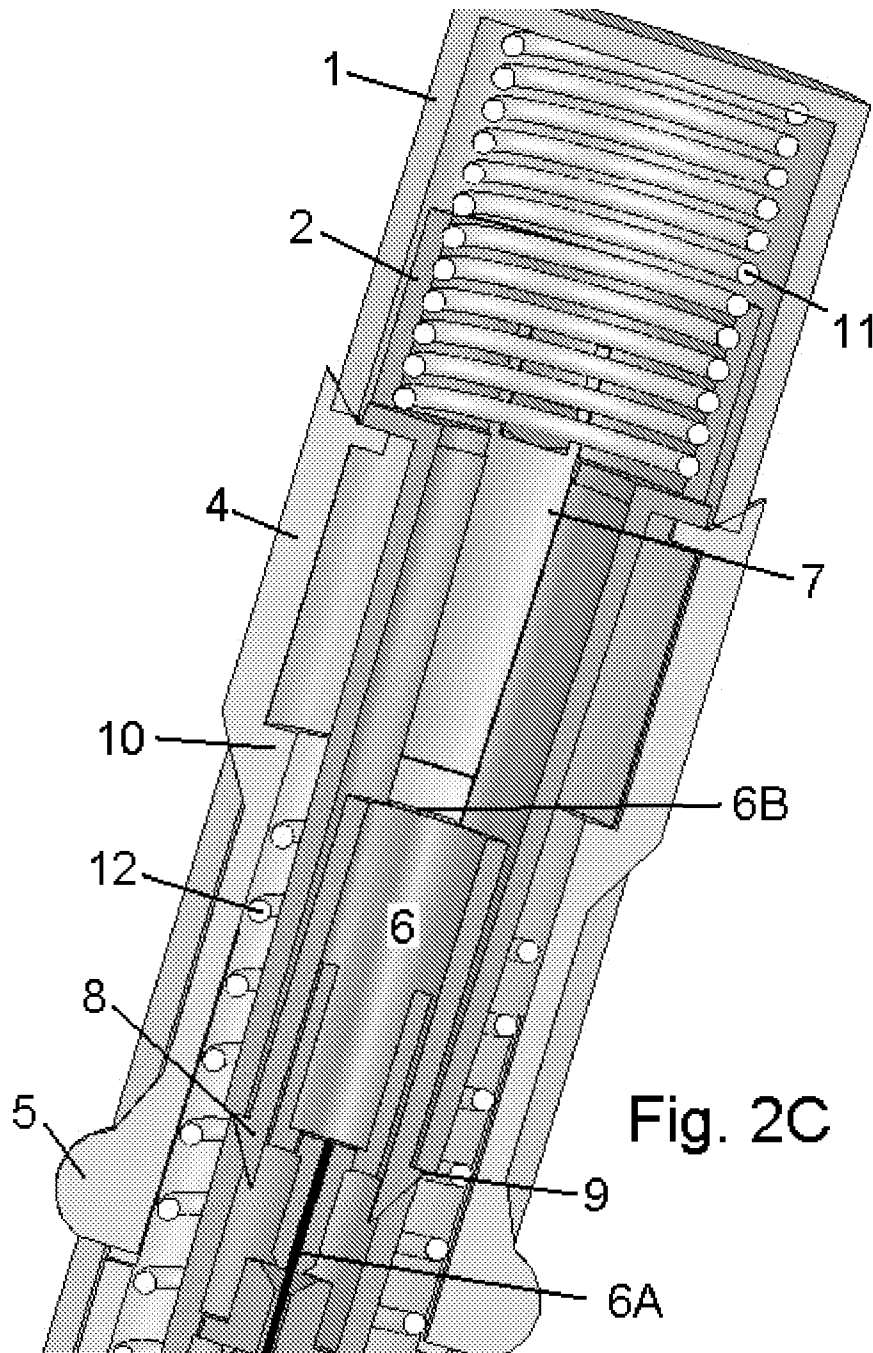

Fig. 2C

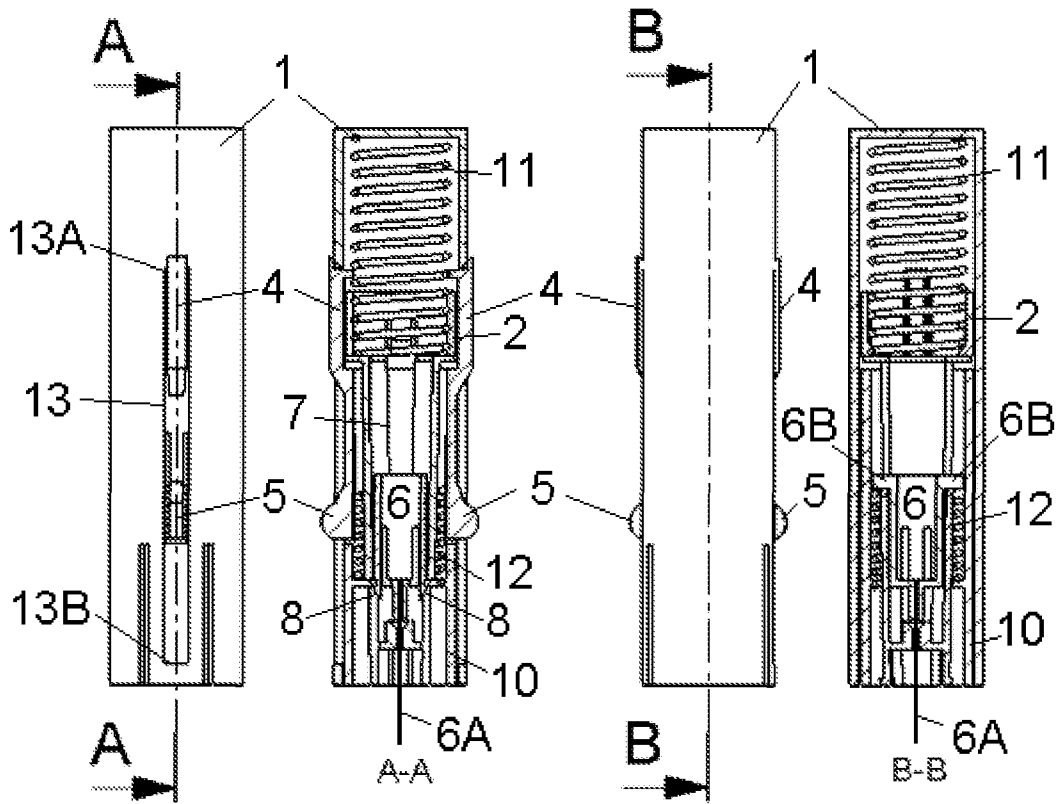

Fig. 3A

Fig. 3B

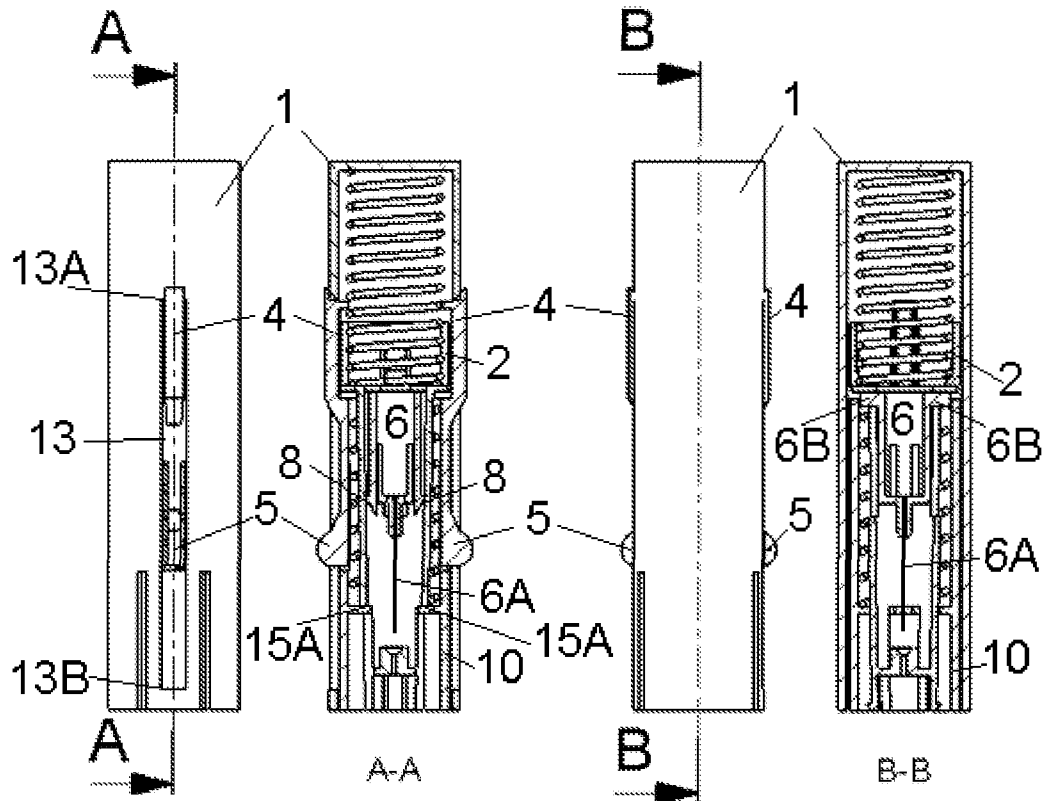

Fig. 4A

Fig. 4B

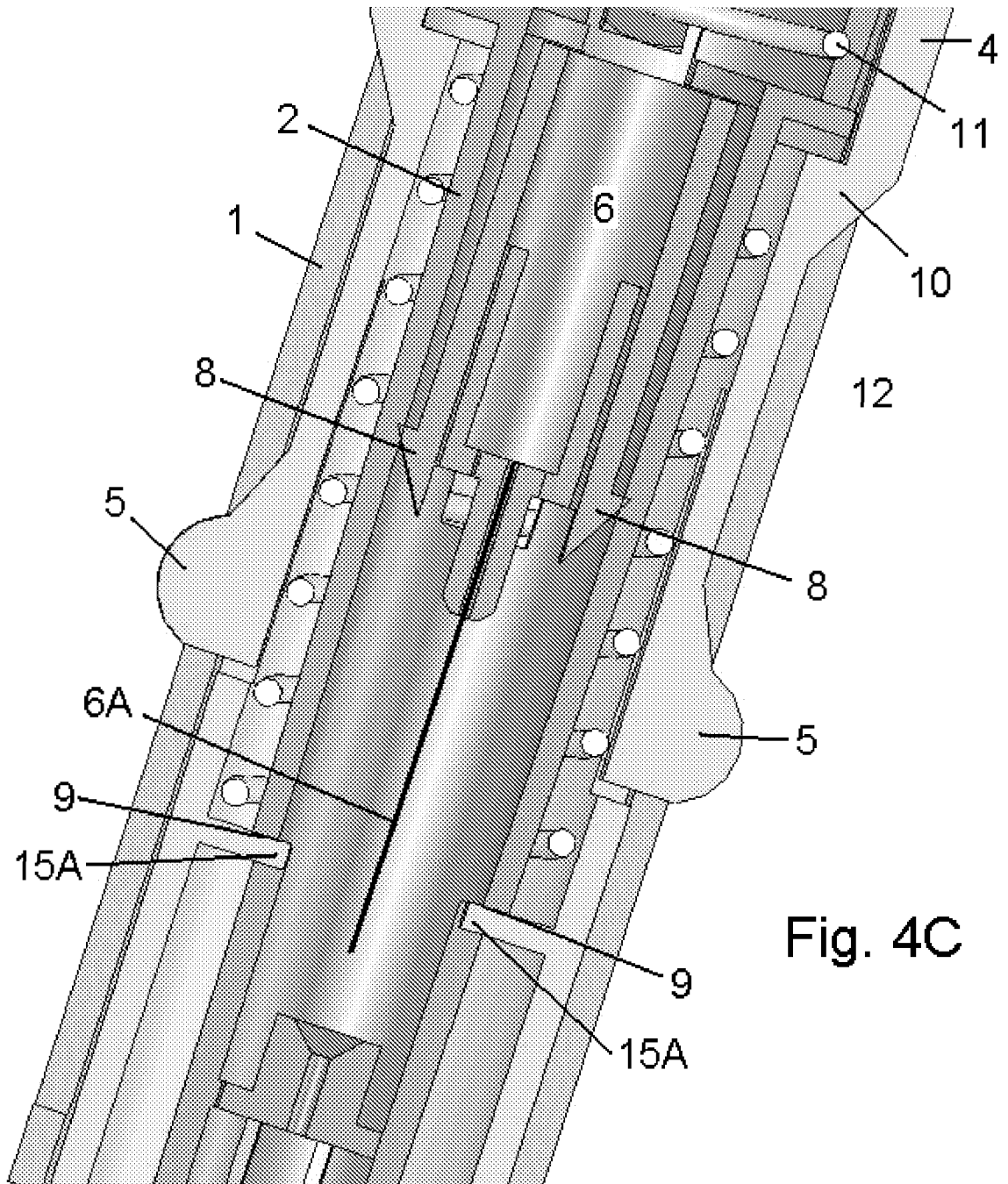

Fig. 4C

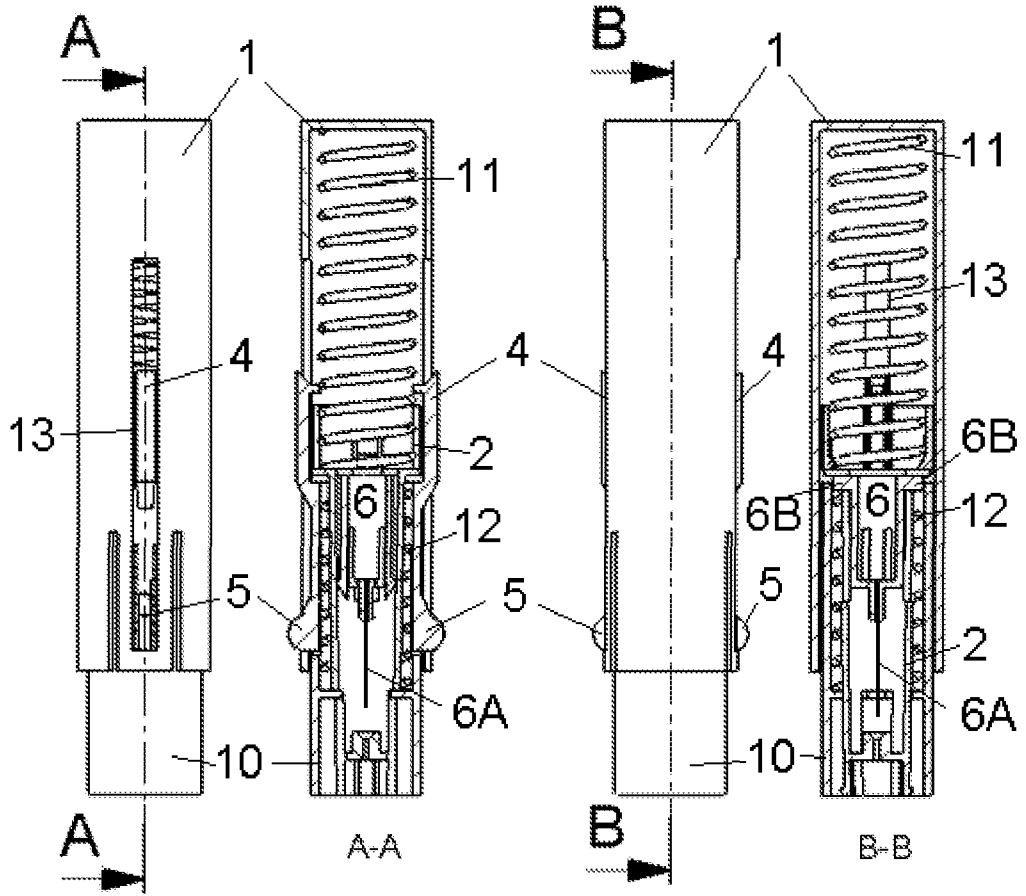

Fig. 5A

Fig. 5B

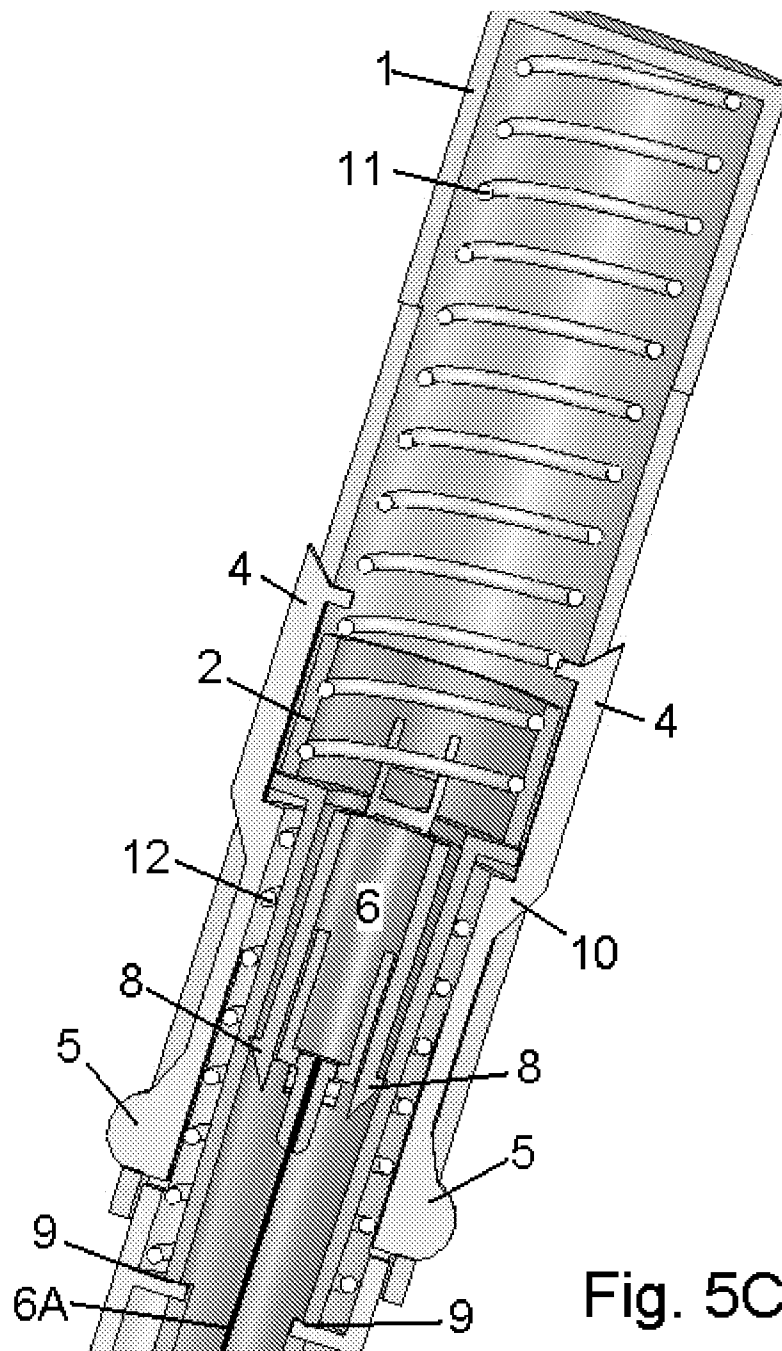

Fig. 5C

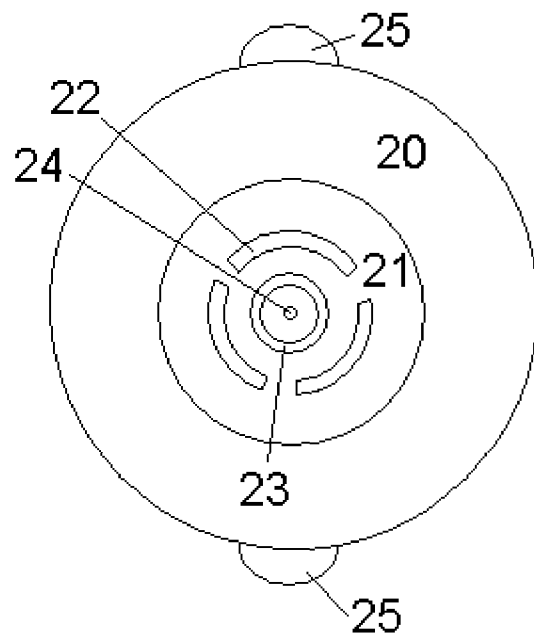
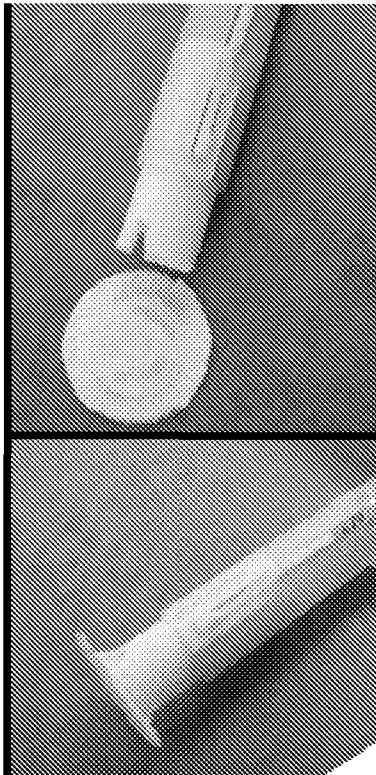

Fig. 6

INTERNATIONAL SEARCH REPORT

International application No
PCT/EP2008/058512

A. CLASSIFICATION OF SUBJECT MATTER INV. A61M5/158 A61M5/32 A61B5/15		
According to International Patent Classification (IPC) or to both national classification and IPC		
B. FIELDS SEARCHED		
Minimum documentation searched (classification system followed by classification symbols) A61M		
Documentation searched other than minimum documentation to the extent that such documents are included in the fields searched		
Electronic data base consulted during the international search (name of data base and, where practical, search terms used) EPO-Internal		
C. DOCUMENTS CONSIDERED TO BE RELEVANT		
Category*	Citation of document, with indication, where appropriate, of the relevant passages	Relevant to claim No.
X	US 5 176 643 A (KRAMER GEORGE C [US] ET AL) 5 January 1993 (1993-01-05) column 4, line 46 - line 61 column 5, line 9 - line 13 figures 1-5	1-4,7
Y	-----	8,10,11
Y	WO 2005/046780 A (SMITHS MEDICAL MD INC [US]; COTE STEVE [US]; MARRS JAMES [US]; FAUST M) 26 May 2005 (2005-05-26) cited in the application page 26, line 30 - page 27, line 18 page 27, line 4 - line 12 figure 102	8,10,11
----- -/--		
<input checked="" type="checkbox"/> Further documents are listed in the continuation of Box C. <input checked="" type="checkbox"/> See patent family annex.		
* Special categories of cited documents :		
A document defining the general state of the art which is not considered to be of particular relevance *E* earlier document but published on or after the international filing date *L* document which may throw doubts on priority claim(s) or which is cited to establish the publication date of another citation or other special reason (as specified) *O* document referring to an oral disclosure, use, exhibition or other means *P* document published prior to the international filing date but later than the priority date claimed	*T* later document published after the international filing date or priority date and not in conflict with the application but cited to understand the principle or theory underlying the invention *X* document of particular relevance; the claimed invention cannot be considered novel or cannot be considered to involve an inventive step when the document is taken alone *Y* document of particular relevance; the claimed invention cannot be considered to involve an inventive step when the document is combined with one or more other such documents, such combination being obvious to a person skilled in the art. *&* document member of the same patent family	
Date of the actual completion of the international search	Date of mailing of the international search report	
26 September 2008	06/10/2008	
Name and mailing address of the ISA/ European Patent Office, P.B. 5818 Patentlaan 2 NL - 2280 HV Rijswijk Tel. (+31-70) 340-2040, Tx. 31 651 epo nl, Fax: (+31-70) 340-3016	Authorized officer Sedy, Radim	

INTERNATIONAL SEARCH REPORT

International application No
PCT/EP2008/058512

C(Continuation). DOCUMENTS CONSIDERED TO BE RELEVANT		
Category*	Citation of document, with indication, where appropriate, of the relevant passages	Relevant to claim No.
A	WO 2004/054644 A (SAFE T LTD [GB]; JEFFREY PETER [GB]) 1 July 2004 (2004-07-01) page 9, line 23 - line 26 figures 3A,3B -----	1
A	US 5 271 744 A (KRAMER GEORGE C [US] ET AL) 21 December 1993 (1993-12-21) column 4, line 51 - line 66 figures 1-3 -----	9
A	WO 2007/020090 A (L & N PLAST VERTRIEBS GMBH [DE]; NEUHOLD ARNOLD [DE]) 22 February 2007 (2007-02-22) figure 3 -----	12,13

INTERNATIONAL SEARCH REPORT

International application No.
PCT/EP2008/058512

Box No. II Observations where certain claims were found unsearchable (Continuation of item 2 of first sheet)

This international search report has not been established in respect of certain claims under Article 17(2)(a) for the following reasons:

1. Claims Nos.: 14
because they relate to subject matter not required to be searched by this Authority, namely:
Rule 39.1(iv) PCT - Method for treatment of the human or animal body by surgery
2. Claims Nos.:
because they relate to parts of the international application that do not comply with the prescribed requirements to such an extent that no meaningful international search can be carried out, specifically:
3. Claims Nos.:
because they are dependent claims and are not drafted in accordance with the second and third sentences of Rule 6.4(a).

Box No. III Observations where unity of invention is lacking (Continuation of item 3 of first sheet)

This International Searching Authority found multiple inventions in this international application, as follows:

1. As all required additional search fees were timely paid by the applicant, this international search report covers allsearchable claims.
2. As all searchable claims could be searched without effort justifying an additional fees, this Authority did not invite payment of additional fees.
3. As only some of the required additional search fees were timely paid by the applicant, this international search report covers only those claims for which fees were paid, specifically claims Nos.:
4. No required additional search fees were timely paid by the applicant. Consequently, this international search report is restricted to the invention first mentioned in the claims; it is covered by claims Nos.:

Remark on Protest

- The additional search fees were accompanied by the applicant's protest and, where applicable, the payment of a protest fee.
- The additional search fees were accompanied by the applicant's protest but the applicable protest fee was not paid within the time limit specified in the invitation.
- No protest accompanied the payment of additional search fees.

INTERNATIONAL SEARCH REPORT

Information on patent family members

International application No

PCT/EP2008/058512

Patent document cited in search report	Publication date	Patent family member(s)	Publication date
US 5176643	A	05-01-1993	AU 659374 B2 11-05-1995
			AU 1912492 A 21-12-1992
			AU 2843095 A 12-10-1995
			CA 2109106 A1 12-11-1992
			EP 0582651 A1 16-02-1994
			JP 6508773 T 06-10-1994
			WO 9219296 A2 12-11-1992
WO 2005046780	A	26-05-2005	AU 2004289183 A1 26-05-2005
			CA 2544299 A1 26-05-2005
			CN 1878592 A 13-12-2006
			EP 1684840 A1 02-08-2006
			JP 2007510497 T 26-04-2007
			US 2005101932 A1 12-05-2005
WO 2004054644	A	01-07-2004	AU 2003292410 A1 09-07-2004
			CA 2508426 A1 01-07-2004
			EP 1581289 A1 05-10-2005
			JP 2006509568 T 23-03-2006
			US 2005288633 A1 29-12-2005
US 5271744	A	21-12-1993	US 5451210 A 19-09-1995
			US 5405362 A 11-04-1995
WO 2007020090	A	22-02-2007	DE 102005038933 A1 22-02-2007
			EP 1846067 A1 24-10-2007