

L. T. KUEHL.
 STEAM GENERATOR.
 APPLICATION FILED MAY 17, 1909.

950,293.

Patented Feb. 22, 1910.

FIG. 1.

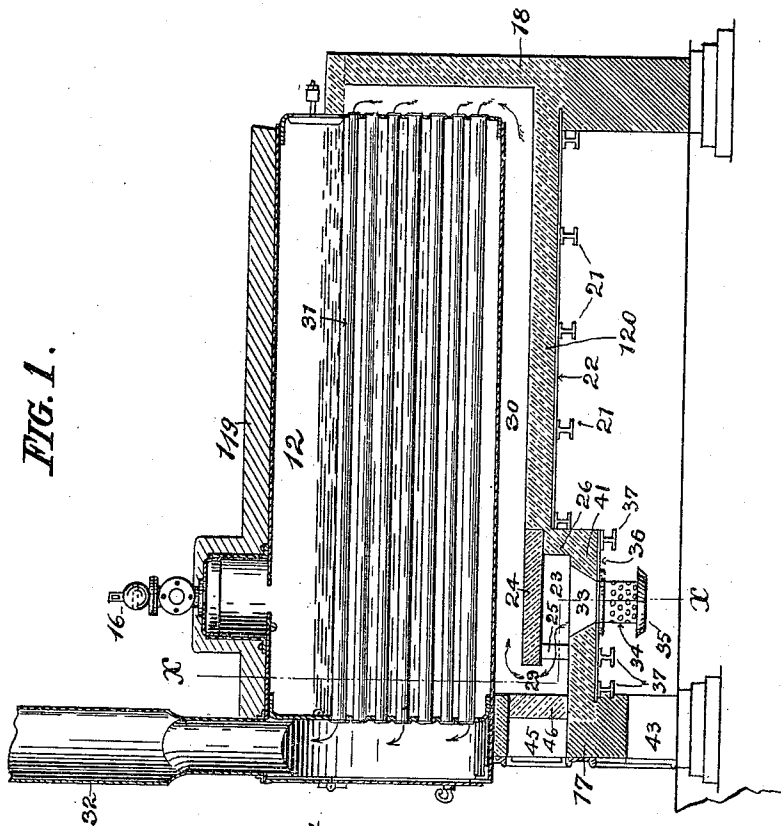
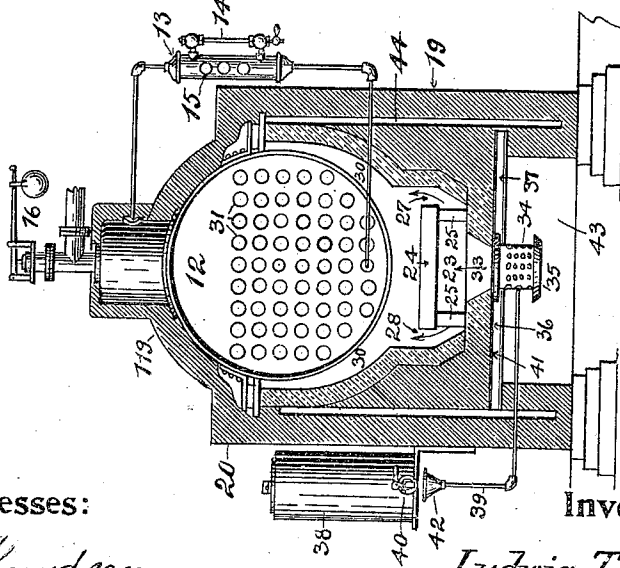

FIG. 2.



Witnesses:

C. B. Knudsen
E. Wabel

Inventor:

Ludwig T. Kuehl

BY

Michael J. Stack & Sons

Attorneys.

UNITED STATES PATENT OFFICE.

LUDWIG T. KUEHL, OF CHICAGO, ILLINOIS, ASSIGNOR TO GEORGE C. J. KUEHL, OF CHICAGO, ILLINOIS.

STEAM-GENERATOR.

950,293.

Specification of Letters Patent. Patented Feb. 22, 1910.

Application filed May 17, 1909. Serial No. 496,363.

To all whom it may concern:

Be it known that I, LUDWIG T. KUEHL, a citizen of the United States, and resident of Chicago, in the county of Cook and State of Illinois, have invented certain new and useful Improvements in Steam-Generators; and I do hereby declare that the following description of my said invention, taken in connection with the accompanying sheet of drawings, forms a full, clear, and exact specification, which will enable others skilled in the art to which it appertains to make and use the same.

This invention has general reference to steam generators; and it consists, essentially, in the novel and peculiar combination of parts and details of construction, as hereinafter first fully set forth and described, and then pointed out in the claims.

This invention has for its object the construction of a steam-generator in which liquid fuel, such as crude coal-oil, petroleum, and the heavier hydro-carbons are employed for the generation of steam.

In the drawings already mentioned, which serve to illustrate this invention more fully, Figure 1 is a longitudinal sectional elevation of this improved steam-generator. Fig. 2 is a transverse sectional elevation on line *x x* of Fig. 1.

Like parts are designated by corresponding characters of reference in both figures.

In these drawings the reference-numeral 12 designates a steam-generator which may be of any desired construction, my invention being applicable to all of the various types of steam-generators. This boiler 12 is provided with the required appurtenants, such as a water-column 13; gage-glass 14, gage-cocks 15, safety-valve 16; and it is erected in a brick setting or structure composing front wall 17, rear wall 18; side-walls 19 and 20, and it is, preferably, covered by a nonconductor of heat 119 on its upper surface.

120 is the lower wall of the boiler-setting. It is carried upon transverse beams or girders 21, there being a sheet metal plate 22, above the I beams 21, to sustain the brick-wall 120.

The space behind the front wall 17 and below the steam-generator 12 forms a combustion chamber 23, there being in said combustion chamber a horizontally disposed baffle-plate 24, which baffle-plate is preferably a

slab of refractory material which on one end is carried upon supports 25, and at its other end upon the bridge-wall 26. It is narrower than the width of the combustion chamber 23 and shorter than the space between the front-wall and the bridge-wall to afford side passages 27 and 28, and a forward passage 29, for the gases of combustion, which are carried backward underneath the boiler through the crescent-shaped passage 30 and returned through the boiler-flues 31 to escape into the stack 32.

In the lower wall 41 of the combustion chamber there is a vertical, outwardly-flaring, passage 33, which connects with, and forms a continuation of, a burner, which burner may be of any of the various types of oil-burners, but is, preferably, one which is fully described in the Letters Patent of the United States granted to me on the 6th day of April 1909, No. 917,460 and consisting of a perforated shell or tube 34, having a pan 35 underneath, said perforated tube 34 being suitably fastened to a sheet-metal plate 36, carried upon I-beams 37, and sustaining the lower wall 41 of the combustion chamber. This burner is supplied with liquid fuel from a tank 38, by a tube 39, which tube enters the perforated shell or tube 34 of the burner, and discharges the liquid fuel into the pan 35. And in order that the amount of the liquid fuel supplied to the burner may, at all times, be accurately gaged, the tank 38 is fitted with a regulating-valve 40, there being a funnel 42, at the upper end of the supply-pipe 39, into which the liquid fuel issuing from the regulating valve 40 discharges and which liquid fuel is, therefore, in sight so that the flow of liquid fuel may be easily seen and regulated.

In operation, liquid fuel is allowed to run into the pan 35 until nearly full, which fuel when ignited by a torch or other suitable instruments introduced through the opening 43 in the front wall 17, is sufficient to initially heat the burner, after which, the supply of fuel is more fully turned on. The gas generated from, and the atoms of liquid fuel not converted into, gas, rise in the perforated tube 34 and air, entering through the perforations in said tube 34 and combining with the carbon of the fuel produces an intensely hot flame which enters the combustion chamber and, by the baffle plate 24, is spread and passes through the passages

27, 28 and 29 underneath the boiler and thence backward through the crescent-shaped passage 30 and through the boiler-flues 31 into the smoke-stack 32.

5 The portion of all walls with which the gases of combustion are coming in contact, are preferably built up of fire-bricks, and these walls are separated from the outer walls of the structure by air-spaces 44, as
10 clearly illustrated in Fig. 2, to form non-conducting spaces and also to prevent the outer walls from cracking or opening of the joints of the brick-work caused by the unequal expansion and contraction of the inner
15 and outer wall-portions.

The baffle plate 24 is, as heretofore mentioned, preferably formed of a single slab of refractory material, such as fire-clay and since it becomes white-hot when the boiler
20 is being fired, and, therefore, sooner or later requires renewal, there is in the front-wall an opening 45 corresponding to the firing opening in coal-fired boilers, which opening is closed by a fire-brick wall 46, which wall
25 may be readily removed when access is to be had to the combustion chamber for the renewal of the baffle-plate 24, or for other necessary repairs, or inspection.

I have heretofore described, and in the
30 drawings I have illustrated a steam-generator fitted with but one burner adapted to consume liquid fuel, but it is evident that whenever necessary, two or more of these burners may be installed in order to supply the required
35 heat, the number of burners to be employed depending upon the size of the boiler proper and the amount of steam and the pressure thereof which it is necessary to produce.

40 Having thus fully described this invention, I claim as new and desire to secure to me by Letters Patent of the United States—

1. The combination, with a boiler, of a brick-setting for the same, and a burner adapted to burn hydrocarbon fuel, there be-

ing in said brick-setting a flaring passage 45 above said burner, a combustion-chamber co-acting with said flaring passage, a baffle-plate above said flaring passage and consisting of a slab of refractory material, supports for said baffle-plate, passages around three
50 of the four sides of said baffle-plate; a crescent-shaped passage around the boiler and a vertical passage in the rear of said boiler.

2. The combination, with a steam-gener- 55 ator proper, of means for generating the required heat, said means including a burner adapted to burn hydrocarbon fuel, and a brick-setting for the boiler proper, there being in said brick-setting a combustion cham- 60 ber; a flaring passage into said combustion chamber; a baffle plate above said flaring passage; front, and side passages leading from said combustion chamber around said baffle plate, a crescent-shaped passage under- 65 neath the boiler proper and a vertical passage on the back of said boiler.

3. A steam generator, comprising a boiler proper; a brick-setting for said boiler, and a burner adapted to burn hydrocarbon fuel; 70 there being in said brick-setting a flaring passage above said burner, a combustion-chamber in communication with said flaring passage, a baffle-plate above said flaring passage and consisting of refractory ma- 75 terial, supports for said baffle-plate, passages around three of the four sides of the said baffle-plate, a crescent-shaped passage around the lower, longitudinal, portion of said boiler, and a vertical passage in the rear of 80 said boiler.

In testimony that I claim the foregoing as my invention, I have hereunto set my hand in the presence of two subscribing witnesses.

L. T. KUEHL.

Witnesses:

GEORGE C. J. KUEHL,
MICHAEL J. STARK.