



(19) **United States**

(12) **Patent Application Publication**
Cobian

(10) **Pub. No.: US 2005/0217141 A1**

(43) **Pub. Date: Oct. 6, 2005**

(54) **SANDALS WITH DRAINAGE SYSTEM**

(52) **U.S. Cl. 36/3 B; 36/11.5**

(76) **Inventor: John Cobian, San Marcos, CA (US)**

(57) **ABSTRACT**

Correspondence Address:
Wolff & Samson PC
One Boland Drive
West Orange, NJ 07052 (US)

A sandal with a drainage system is provided. The sandal includes a footbed having an upper support surface, a bottom sole, and a central portion therebetween. A plurality of drainage apertures are provided on the upper support surface of the footbed. A vertical drainage channel extends from each drainage aperture into the central portion of the footbed. A plurality of horizontal drainage channels extend within the central portion of the footbed from the vertical drainage channels to exit apertures about a peripheral edge of the sandal.

(21) **Appl. No.: 10/815,466**

(22) **Filed: Apr. 1, 2004**

Publication Classification

(51) **Int. Cl.⁷ A43B 3/12**

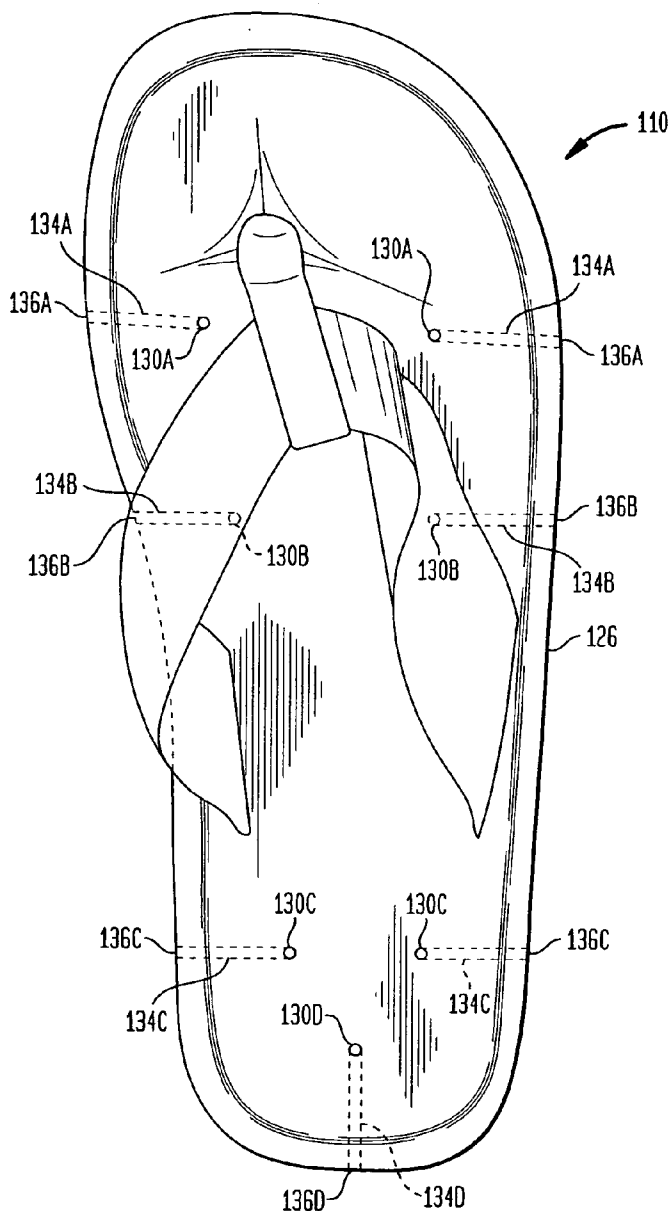

FIG. 1

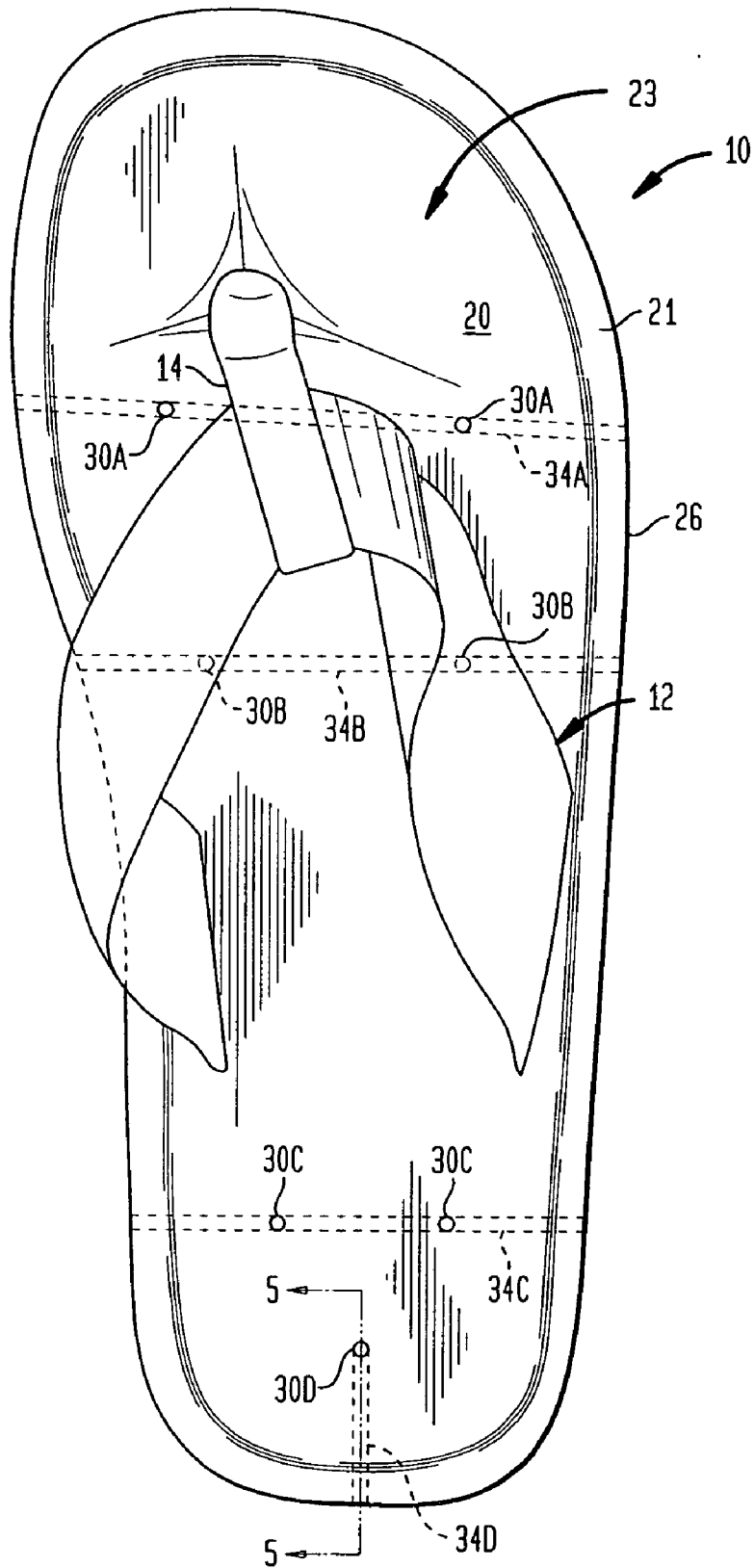

FIG. 2

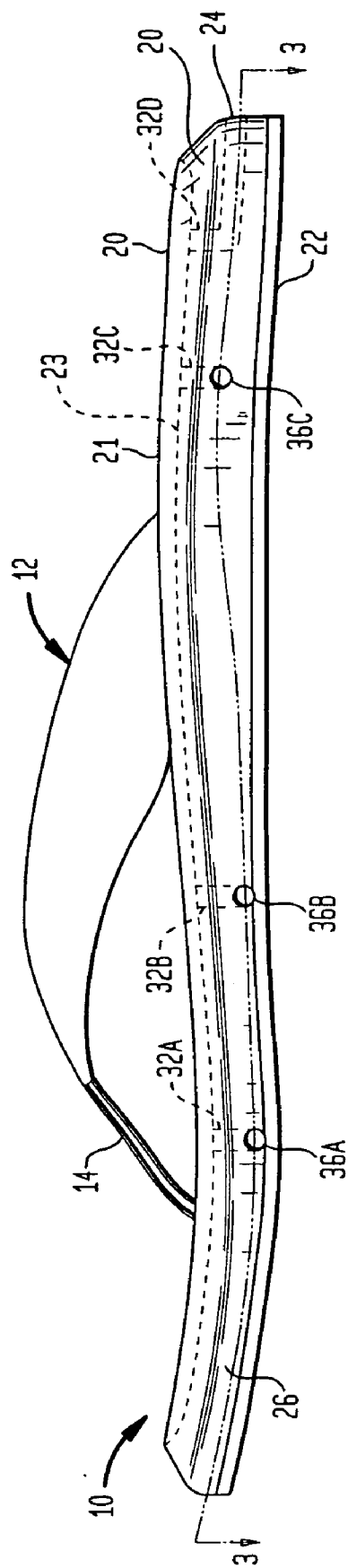

FIG. 3

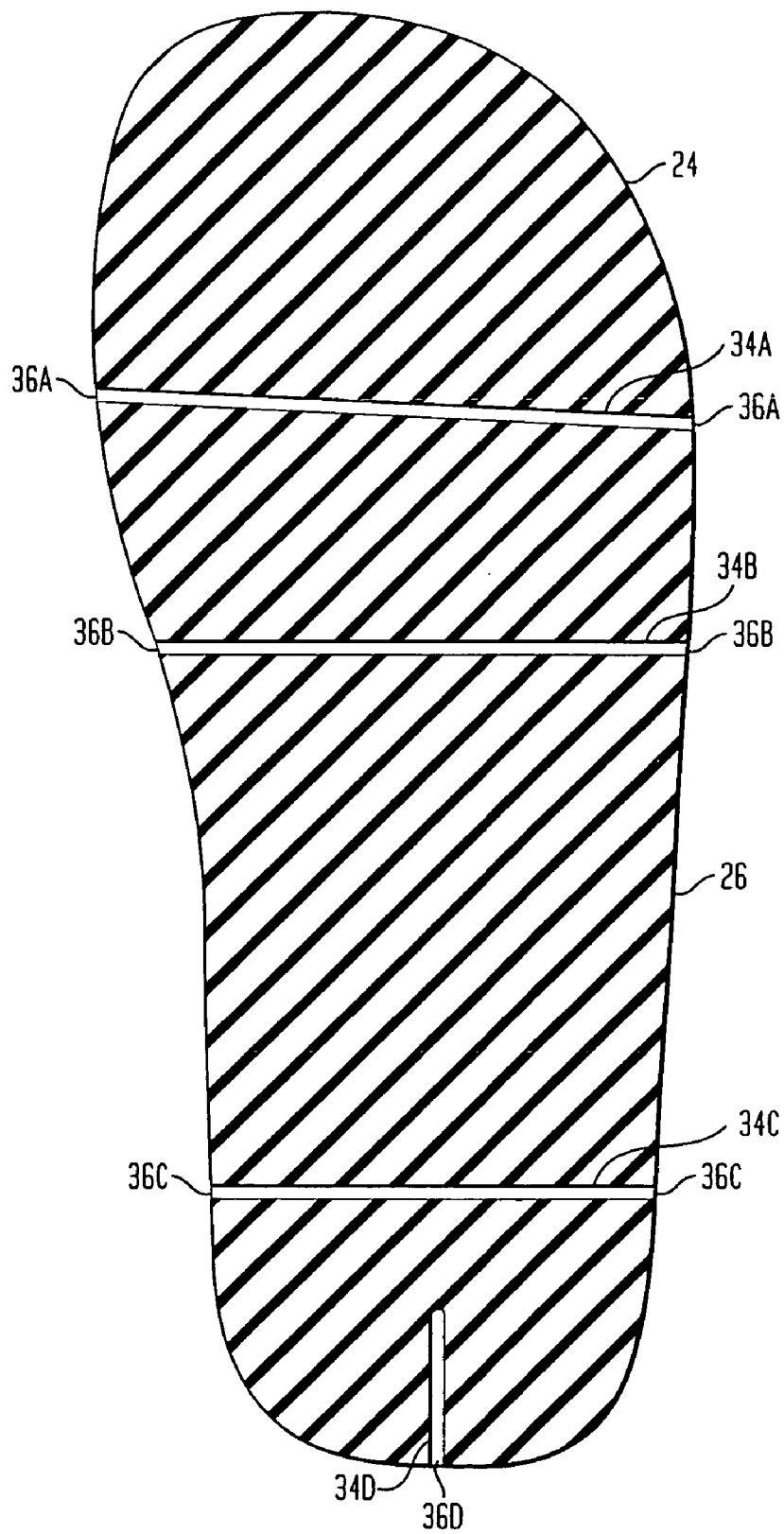

FIG. 4

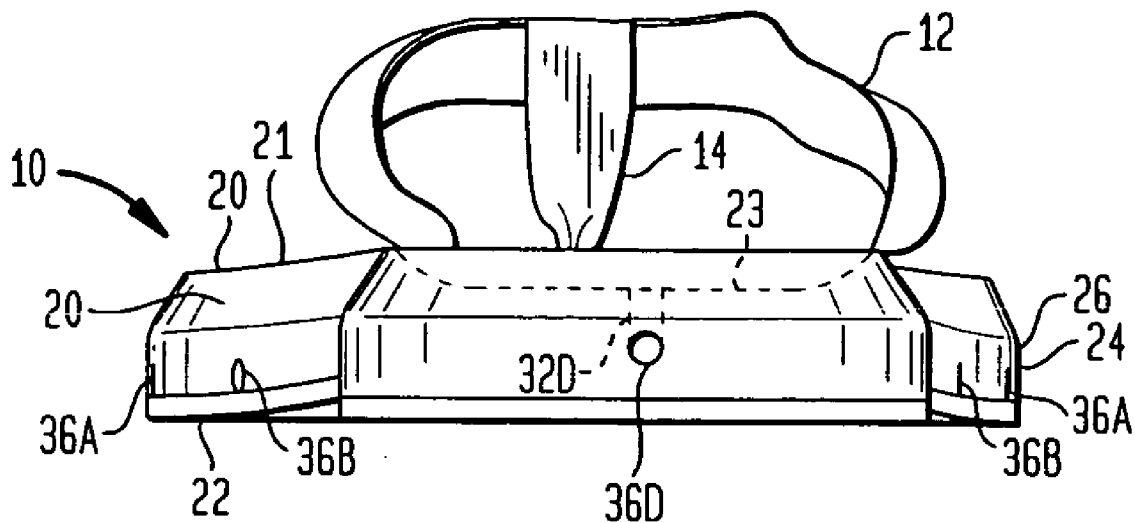

FIG. 5

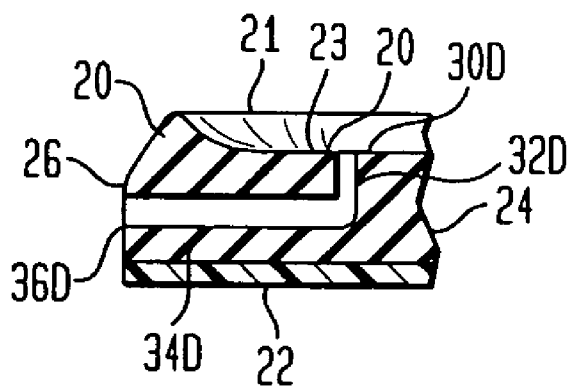

FIG. 6

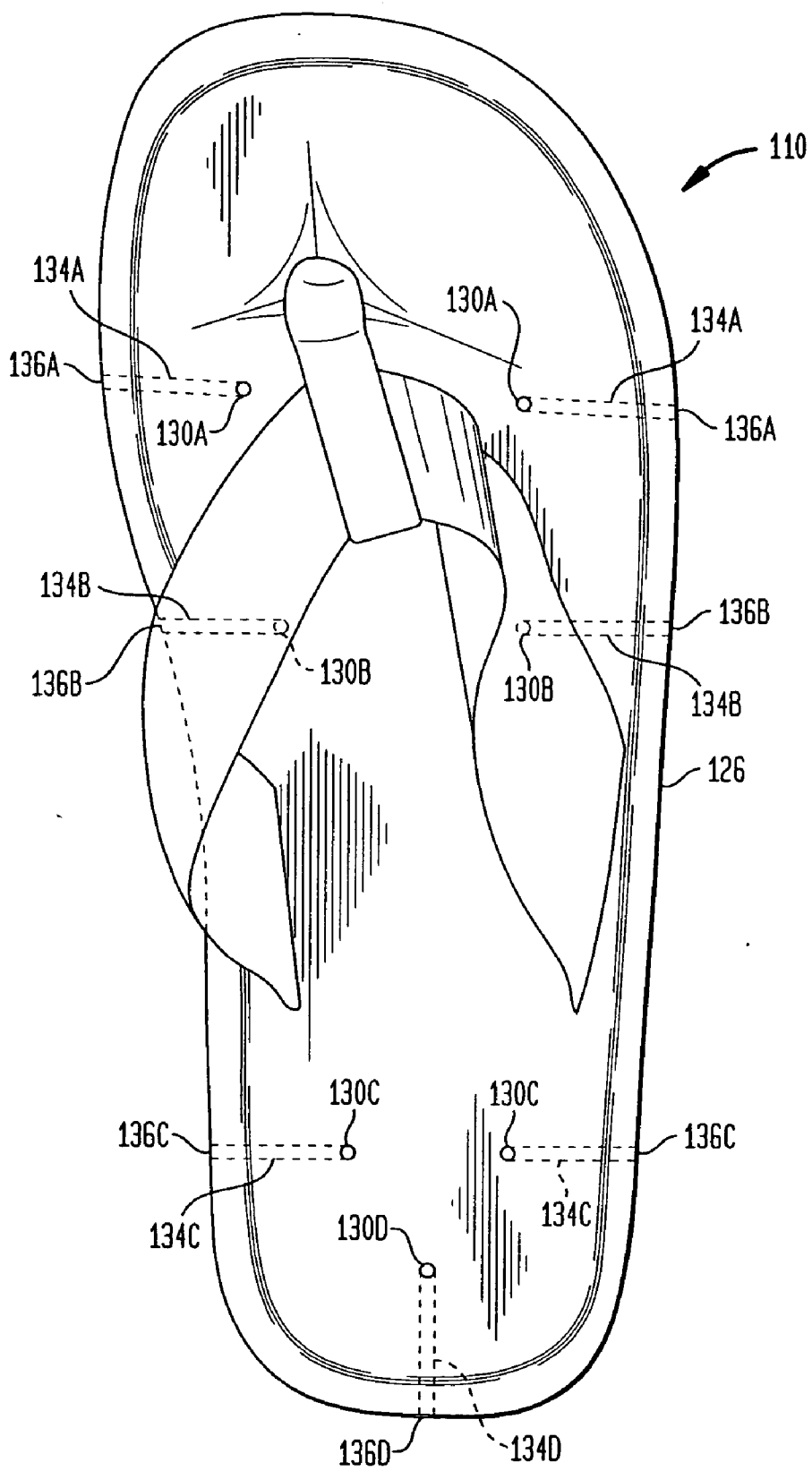
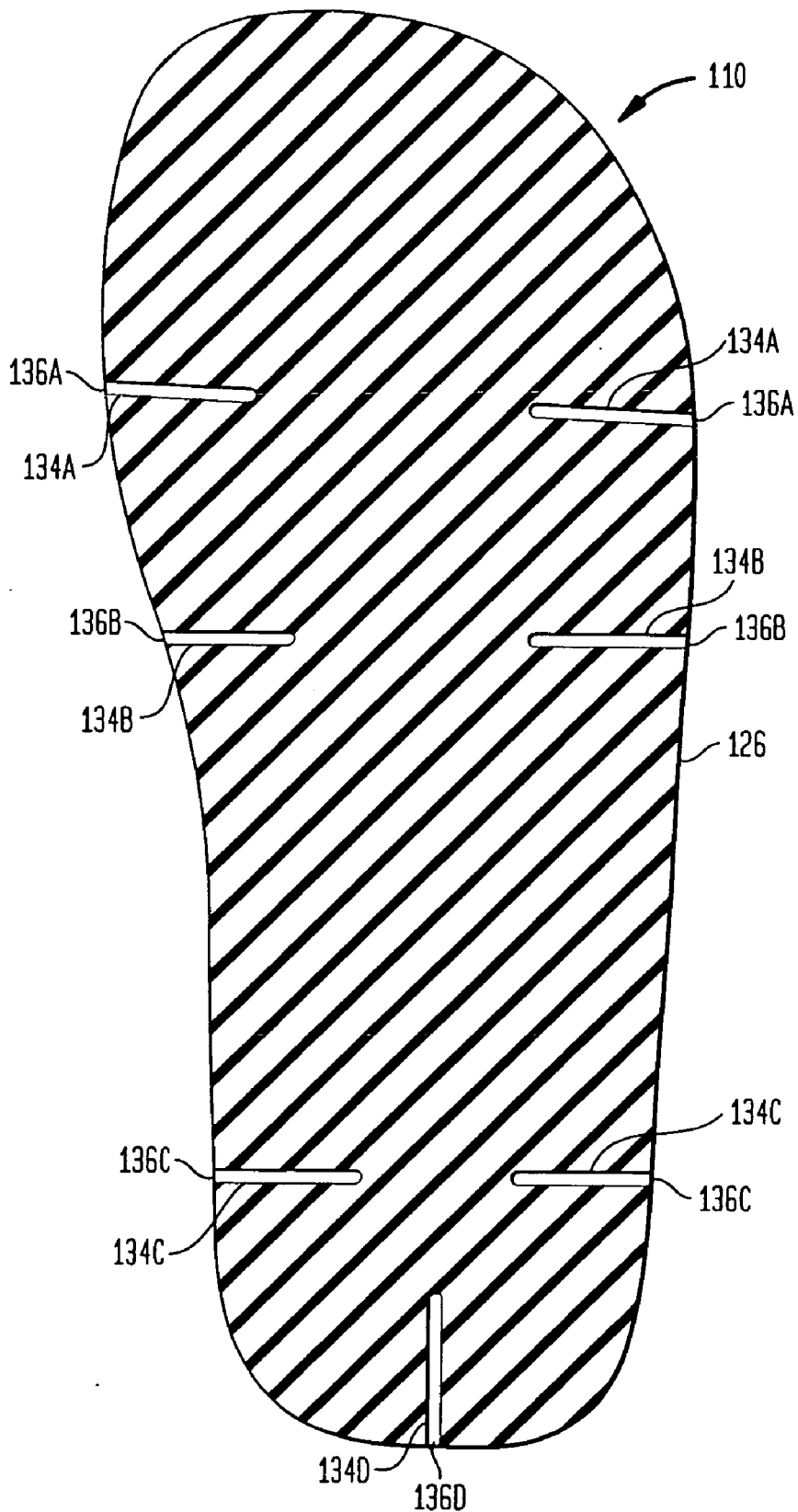

FIG. 7



SANDALS WITH DRAINAGE SYSTEM

BACKGROUND OF THE INVENTION

[0001] 1. Field of the Invention

[0002] The present invention relates to articles of footwear, such as sandals, which include a drainage system.

[0003] 2. Related Art

[0004] Sandals, such as “flip-flops,” “slides,” “thongs,” and other similar types of footwear, are often worn in environments where people participate in recreational water activities. Sandals are easy to put on and take off, and are often put onto wet feet when a person exits a water environment. As such, the upper surface of the sandal can become wet and slippery. Accordingly, it is desirable to drain water away from the surface of the sandal. It is also desirable to keep the water away from the underside of the sole of the sandal to minimize water under the sandal, thereby minimizing the chance of the bottom of the sandal slipping on wet ground.

[0005] Most prior sandal designs do not provide for any sort of drainage, and particularly, do not provide for any drainage from an upper surface of the sandal, through the footbed, and to the peripheral edge of the sandal. Accordingly, what is desired, and has not heretofore been provided, is a sandal with a drainage system to drain water from the upper surface of the sandal, through the footbed and out a drainage channel to exit apertures about the peripheral edge of the sandal.

SUMMARY OF THE INVENTION

[0006] The present invention provides a sandal with a drainage system. The sandal includes a footbed having an upper support surface, a bottom sole, and a central portion therebetween. A retaining strap is interconnected with the footbed for retaining the sandal on a foot. A plurality of drainage apertures are provided on the upper support surface of the footbed. A vertical drainage channel extends from each drainage aperture into the central portion of the footbed. A plurality of horizontal drainage channels extend within the central portion of the footbed from the vertical drainage channels to exit apertures about a peripheral edge of the sandal.

[0007] In one embodiment, the sandal of the present invention includes two forward drainage apertures on the upper support surface of the footbed with forward vertical drainage channels extending from each aperture into the central portion of a footbed. A forward horizontal drainage channel extends from a medial side to a lateral side of the peripheral edge of the sandal and interconnects with the forward vertical drainage channels. The sandal also includes two midsole drainage apertures in the upper support surface from which midsole vertical drainage channels extend into the central footbed. A midsole horizontal drainage channel extends from a medial side to a lateral side of the peripheral edge of the sandal and interconnects with the midsole vertical drainage channels. The sandal further includes two heel drainage apertures in the upper support surface from which extend heel vertical drainage channels that interconnect with a horizontal heel drainage channel, which extends from a medial side to a lateral side of the peripheral edge of the sandal. The sandal additionally includes a rear drainage aperture in the upper support surface from which extends a

rear vertical drainage channel that connects with a horizontal drainage channel, which extends rearward to a back portion of the peripheral edge of the sandal.

[0008] In another embodiment, the sandal of the present invention includes two forward drainage apertures on the upper support surface of the footbed with forward vertical drainage channels extending from each aperture into the central portion of a footbed. Forward horizontal drainage channels interconnect with each vertical drainage channel, and extend from each vertical drainage channel to the peripheral edge of the sandal. The sandal also includes two midsole drainage apertures in the upper support surface from which midsole vertical drainage channels extend into the central footbed. Midsole horizontal drainage channels interconnect with each midsole vertical drainage channel, and extend from each midsole vertical drainage channel to the peripheral edge of the sandal. The sandal further includes two heel drainage apertures in the upper support surface from which extend heel vertical drainage channels that interconnect with horizontal heel drainage channels, which extend from the heel vertical drainage channels to the peripheral edge of the sandal. The sandal additionally includes a rear drainage aperture in the upper support surface from which extends a rear vertical drainage channel that connects with a horizontal drainage channel, which extends rearward to a back portion of the peripheral edge of the sandal. In this embodiment, the number and location of drainage apertures can be varied, but each drainage aperture is associated with a dedicated drainage channel, including a vertical and a horizontal drainage channel.

BRIEF DESCRIPTION OF THE DRAWINGS

[0009] Other important objects and features of the invention will be apparent from the following Detailed Description of the Invention taken in connection with the accompanying drawings in which:

[0010] **FIG. 1** is a top view of a sandal with a drainage system of the present invention.

[0011] **FIG. 2** is a side view of the sandal shown in **FIG. 1**.

[0012] **FIG. 3** is a cross-sectional view of the sandal shown in **FIG. 2**, taken along the line 3-3.

[0013] **FIG. 4** is a rear view of the sandal shown in **FIG. 1**.

[0014] **FIG. 5** is a partial cross-sectional view of the sandal shown in **FIG. 1**, taken along the line 5-5.

[0015] **FIG. 6** is a top view of another embodiment of a sandal with the drainage system of the present invention.

[0016] **FIG. 7** is a cross-sectional view of the sandal shown in **FIG. 6**.

DETAILED DESCRIPTION OF THE INVENTION

[0017] The present invention provides a sandal with a drainage system. The sandal includes a footbed having an upper support surface, a bottom sole, and a central portion therebetween. A retaining strap is interconnected with the footbed for retaining the sandal on a foot. A plurality of drainage apertures are provided on the upper support surface

of the footbed. A vertical drainage channel extends from each drainage aperture into the central portion of the footbed. By the term "vertical" it is meant a direction generally perpendicular to the footbed. A plurality of horizontal drainage channels extend within the central portion of the footbed from the vertical drainage channels to exit apertures about a peripheral edge of the sandal. By the term "horizontal" it is meant a direction generally parallel to the bottom sole of the sandal. Of course, the horizontal channels could be pitched to aid drainage, if desired.

[0018] The sandal of the present invention is shown in FIGS. 1-7. FIG. 1 is a top view of the sandal, generally indicated at 10. The sandal 10 includes a foot strap 12 that can be configured and attached in accordance with what is known in the art. The foot strap 12 may include a strap retainer 14 which fits between the toes of a foot. However, such a strap retainer 14 is not required. Further, the foot strap 12 and retainer 14 could be substituted with an upper of any desired design, to create a flip-flop, thong, slide, or other desired style. The sandal 10 includes a footbed having an upper surface 20 and a peripheral edge 26. The size and shape of the footbed can be varied in accordance with what is known in the art. Additionally, the materials from which the footbed is constructed can be varied in accordance with what is known in the art.

[0019] The footbed of the present invention includes a three layer construction: an upper surface 20, a bottom sole (FIG. 2, reference numeral 22) and a central footbed portion (FIG. 2, reference numeral 24). The upper surface 20 could be a finished surface of the central footbed portion. However, the present invention could be implemented wherein the footbed has any desired number of layers. The upper surface 20 could include a ridge 21 that follows the peripheral edge 26 and is spaced inwardly therefrom. A depression 23 is surrounded by the ridge 21. The depression 23 receives a foot and aids drainage.

[0020] The upper surface of the footbed has a plurality of drainage apertures including forward drainage apertures 30A, midsole drainage apertures 30B, heel drainage apertures 30C, and rear drainage aperture 30D. The number of drainage apertures, as well as the location of the drainage apertures, can be varied as desired.

[0021] As can be seen in phantom in FIG. 1, a plurality of horizontal drainage channels, which are interconnected with vertical drainage channels extending from the drainage apertures, extend to the side wall 26 of the footbed of the sandal 10. As shown in FIG. 1, the sandal 10 includes a forward horizontal drainage channel 34A, a midsole horizontal drainage channel 34B, a heel horizontal drainage channel 34C, and a rear horizontal drainage channel 34D. The forward, midsole, and rear drainage channels extend from medial to lateral sides of the peripheral edge 20 of the footbed of sandal 10. The rear horizontal drainage channel 34D extends to a back portion of the peripheral edge 20 of the footbed of sandal 10. It should be noted that the orientation of the drainage channels need not be limited to a horizontal direction.

[0022] FIG. 2 is a side view of the sandal 10 shown in FIG. 1. As can be seen, the sandal 10 includes a foot strap 12 and a strap retainer 14. Again, the foot strap 12 can be varied in accordance with what is known in the art. For example, it could be a strap, a thong, or other sandal upper

configuration. The footbed includes an upper surface 20, a bottom sole 22, and a central footbed portion 24. Again, this construction can be varied. A plurality of exit apertures are shown along the peripheral edge 26 of the central footbed portion, including forward exit aperture 36A, midsole exit aperture 36B, and heel exit aperture 36C. As shown in phantom, a plurality of vertical drainage channels extend into the footbed from the drainage apertures in the upper surface of the footbed to the horizontal drainage channels, including forward vertical drainage channel 32A, midsole vertical drainage channel 32B, heel vertical drainage channel 32C, and rear vertical drainage channel 32D.

[0023] FIG. 3 is a cross-sectional view of the footbed of the sandal 10 shown in FIG. 2, taken along line 3-3. As can be seen, the central footbed portion 24 includes a plurality of horizontal drainage channels that lead to exit apertures along the peripheral edge 26, including forward drainage channel 34A leading to exit apertures 36A, midsole horizontal drainage channel 34B leading to midsole exit apertures 36B, heel horizontal drainage channels 34C leading to heel exit apertures 36C and rear horizontal drainage channel 34D leading to rear exit aperture 36D.

[0024] FIG. 4 is a rear view of the sandal 10 shown in FIG. 1. The foot strap 12 and retaining strap 14 are shown interconnected with the footbed. The footbed includes an upper surface 20, a central footbed portion 24 and a bottom sole 22. The footbed has a peripheral edge 26. Rear vertical drainage channel 32D is shown in phantom and it leads to rear horizontal drainage channel that extends to exit aperture 36D. Also, along the peripheral edges, forward exit apertures 36A and midsole exit apertures 36B can be seen.

[0025] FIG. 5 is a partial cross-sectional view of the sandal 10 shown in FIG. 1, taken along the line 5-5 to show the construction of the rear portion of the drainage system. As can be seen, the footbed includes upper surface 20, central footbed portion 24 and bottom sole 22. Rear vertical drainage aperture 32D is interconnected with rear horizontal drainage channel 34D, which extends to rear exit aperture 36D at a rear portion of the peripheral edge 26 of the sandal 10.

[0026] In use, water drains from the upper surface 20 of the sandal 10 through the drainage apertures 30A, B, C, D into the vertical drainage channels 32A, B, C, D, through the horizontal drainage channels 34A, B, C, D and out the exit apertures 36A, B, C, D of the peripheral edge 20 of the sandal 10. As such, if the sandal 10 is submersed in water, or exposed to water because a wet bather steps into a pair of the sandals, water will quickly drain off the upper surface 20, through the footbed, out the exit apertures, and away from the shoe to minimize the possibility of slipping, either by the foot slipping on the upper surface of the sandal or the sole of the surface slipping on wet ground. Additionally, because of this drainage feature, the sandal will be maintained in a condition that is comfortable to wear.

[0027] FIG. 6 is a top view of another embodiment of a sandal having the drainage system of the present invention, indicated generally at 110. The construction of the sandal 110 is similar to that shown in FIG. 1 and described earlier. However, in the embodiment shown in FIG. 6, each drainage aperture has its own dedicated drainage channel. As such, forward drainage apertures 130A are interconnected with front exit apertures 136A by front vertical drainage

channels and independent front horizontal drainage channels 134A. Midsole drainage apertures 130B are interconnected with midsole exit apertures 136B by midsole vertical drainage channels and independent midsole horizontal drainage channels 134B. Heel drainage apertures 130C are interconnected with heel exit apertures 136C by heel vertical drainage channels and independent heel horizontal drainage channels 134C. Rear drainage aperture 130D is interconnected with rear exit aperture 136D by a rear vertical drainage channel and a rear horizontal drainage channel 134D. The number of drainage apertures, as well as the location of the drainage apertures, can be varied as desired, and independent horizontal drainage channels interconnected therewith.

[0028] FIG. 7 is a cross-sectional view of the sandal shown in FIG. 6. Each of the drainage apertures 130A, B, C, D shown in FIG. 7 interconnect with independent horizontal drainage channels 134A, B, C, D via vertical drainage channels connected therebetween. The horizontal drainage channels 134A, B, C, D connect to exit apertures 136A, B, C, D on the peripheral edge 126 of the sandal 110. Each of the channels 134A, B, C, D could be pitched to aid drainage. Additionally, the channels 134A, B, C, D could be oriented at any desired angle within the footbed. Each of the channels 134A, B, C, D channels water from the apertures 130A, B, C, D to exit apertures 136A, B, C, D.

[0029] The apertures and drainage channels of the present invention can be formed in accordance with what is known in the art. The drainage system can be formed during the manufacture of the components of the sandal, i.e., during molding of the footbed, or the system can be created after the footbed is manufactured by removing material therefrom. In a preferred embodiment of the present invention, the footbed is molded ethyl vinyl acetate (EVA), but of course, other suitable materials could be used. For example, a rubber outsole could be used. After molding, the footbed is die cut and the upper is lasted to it. The footbed could be glued or otherwise attached to the midsole and/or a bottom sole. The sides can then be sand finished. The drainage system can be formed by drilling the apertures, vertical drainage channels, and horizontal drainage channels into the footbed. The footbed of the sandals of the present invention can be used with any desired style of upper. The upper can be cut from a desired material and sewn to the footbed, or injection molded and applied to the footbed.

[0030] Having thus described the invention in detail, it is to be understood that the foregoing description is not intended to limit the spirit and scope thereof. What is desired to be protected by Letters Patent is set forth in the appended claims.

What is claimed is:

1. A sandal comprising:

a footbed having an upper support surface, a bottom sole and a central portion therebetween;

an upper interconnected with the footbed for retaining the sandal on a foot;

a plurality of drainage apertures formed in the upper support surface of the footbed;

a plurality of vertical drainage channels extending from the drainage apertures into the central portion of the footbed; and

a plurality of horizontal drainage channels within the central portion of the footbed extending from the vertical drainage channels to exit apertures about a peripheral edge of the sandal.

2. The sandal of claim 1, further comprising two forward vertical drainage channels extending from two forward apertures in the upper support surface to a forward horizontal drainage channel extending from a medial side to a lateral side of the peripheral edge of the sandal.

3. The sandal of claim 2, further comprising two midsole vertical drainage channels extending from two midsole apertures in the upper support surface to a midsole horizontal drainage channel extending from a medial side to a lateral side of the peripheral edge of the sandal.

4. The sandal of claim 3, further comprising two heel vertical drainage channels extending from two heel apertures in the upper support surface to a heel horizontal drainage channel extending from a medial side to a lateral side of the peripheral edge of the sandal.

5. The sandal of claim 4, further comprising a rear vertical drainage channel extending from a rear aperture in the upper support surface to a rear horizontal drainage channel extending to the back portion of the peripheral edge of the sandal.

6. The sandal of claim 1, wherein each drainage aperture has a single vertical drainage channel connected to a dedicated horizontal drainage channel.

7. The sandal of claim 6, further comprising two forward vertical drainage channels extending from two forward apertures in the upper support surface to two forward horizontal drainage channels, each of the forward horizontal drainage channels extending from a forward vertical drainage channel to the peripheral edge of the sandal.

8. The sandal of claim 7, further comprising two midsole vertical drainage channels extending from two midsole apertures in the upper support surface to two midsole horizontal drainage channels, each of the midsole horizontal drainage channels extending from a midsole vertical drainage channel to the peripheral edge of the sandal.

9. The sandal of claim 8, further comprising two heel vertical drainage channels extending from two heel apertures in the upper support surface to two heel horizontal drainage channels, each of the heel horizontal drainage channels extending from a heel vertical drainage channel to the peripheral edge of the sandal.

10. The sandal of claim 9, further comprising a rear vertical drainage channel extending from a rear aperture in the upper support surface to a rear horizontal drainage channel extending to the back portion of the peripheral edge of the sandal.

11. The sandal of claim 1, wherein the upper comprises a strap.

12. The sandal of claim 11, further comprising a thong extending between the footbed and the strap.

* * * * *