



(86) Date de dépôt PCT/PCT Filing Date: 2003/11/24
(87) Date publication PCT/PCT Publication Date: 2004/06/10
(85) Entrée phase nationale/National Entry: 2005/05/18
(86) N° demande PCT/PCT Application No.: IB 2003/006330
(87) N° publication PCT/PCT Publication No.: 2004/047906
(30) Priorité/Priority: 2002/11/22 (60/428257) US

(51) Cl.Int.⁷/Int.Cl.⁷ G06K 19/077
(71) Demandeurs/Applicants:
BNC IP SWITZERLAND GMBH, CH;
CORTINA, FRANCISCO MARTINEZ DE VELASCO, MX
(72) Inventeur/Inventor:
CORTINA, FRANCISCO MARTINEZ DE VELASCO, MX
(74) Agent: KIRBY EADES GALE BAKER

(54) Titre : SYSTEME ET PROCEDE DESTINES A FOURNIR DES SOLUTIONS D'IDENTIFICATION SECURISEE AU MOYEN D'UN DISPOSITIF A RADIOFREQUENCES DANS UNE REGION NON METALLISEE CONNECTEE A UNE REGION METALLISEE

(54) Title: RADIO FREQUENCY IDENTIFICATION DEVICE FORMED IN A NON-METALLIZED REGION WITH AN ANTENNA CONNECTED TO AN OUTSIDE METALLIZED REGION, AND METHOD OF MANUFACTURING

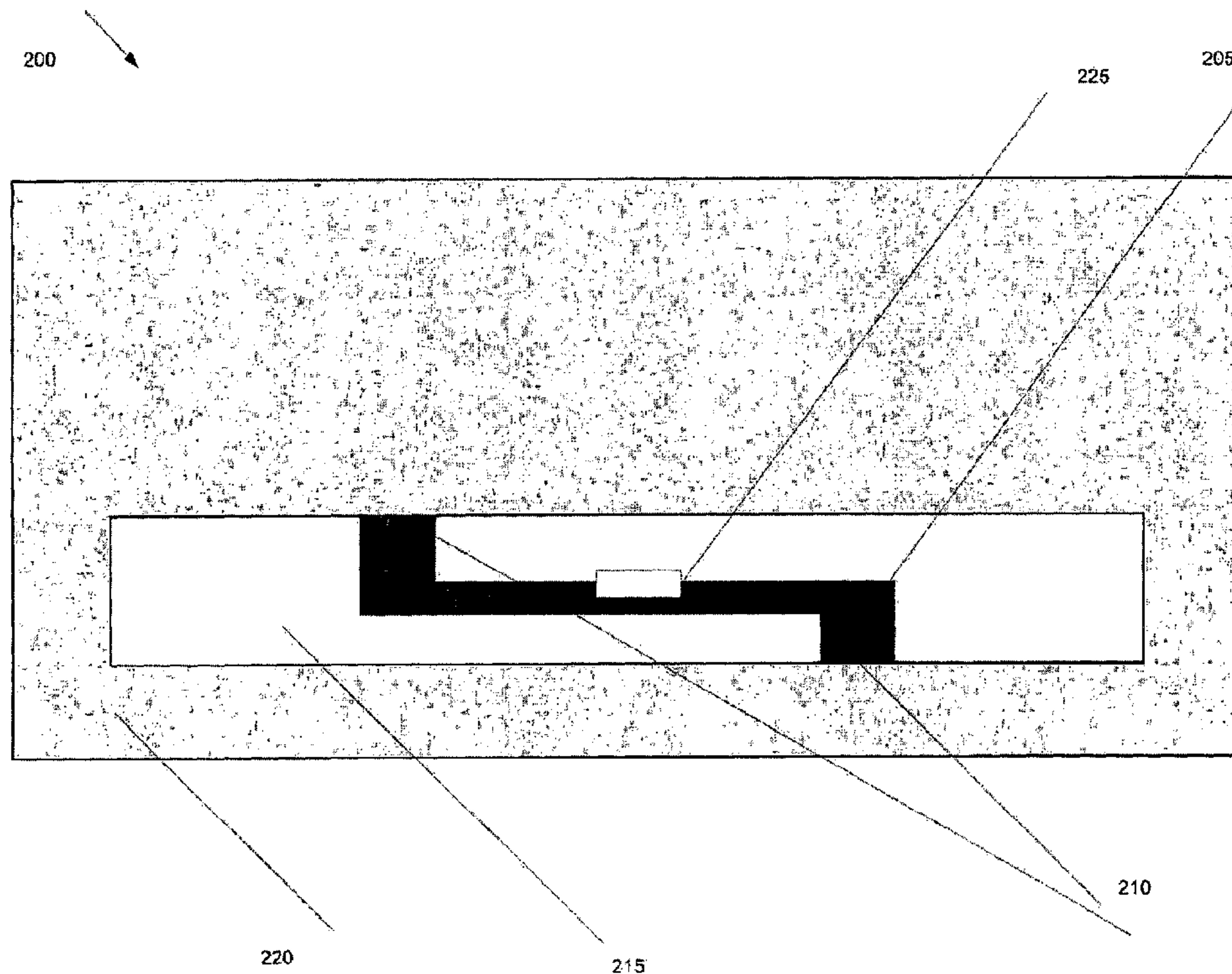

(57) Abrégé/Abstract:

The present invention provides systems and methods for transmitting and receiving information from a radio frequency (RF) transponder. A conductive adhesive (210) connects an antenna (205) in a non-metallized region (215) to a metallized region (220). This feature transforms the entire metallized region of the radio frequency device (i.e., the remainder of the metallized material outside the non-metallized region) into an antenna.

(12) INTERNATIONAL APPLICATION PUBLISHED UNDER THE PATENT COOPERATION TREATY (PCT)

(19) World Intellectual Property
Organization
International Bureau



(43) International Publication Date
10 June 2004 (10.06.2004)

PCT

(10) International Publication Number
WO 2004/047906 A3

(51) International Patent Classification⁷: **G06K 19/077**

(21) International Application Number:
PCT/IB2003/006330

(22) International Filing Date:
24 November 2003 (24.11.2003)

(25) Filing Language: English

(26) Publication Language: English

(30) Priority Data:
60/428257 22 November 2002 (22.11.2002) US

(71) Applicant: **BNC IP Switzerland GmbH** [CH/CH];
Saegestrasse 5, CH-9230 Flawil (CH).

(71) Applicant and

(72) Inventor: **CORTINA, Francisco, Martinez de Velasco**
[MX/MX]; Sierra Amatapec #213, Lomas de Chapultepec,
D.F.11000 (MX).

(74) Agent: **Midgley, Jonathan, Lee**; Marks & Clerk, 57-60
Lincoln's Inn Fields, London WC2A 3LS (GB).

(81) Designated States (*national*): AE, AG, AL, AM, AT, AU,
AZ, BA, BB, BG, BR, BW, BY, BZ, CA, CH, CN, CO, CR,

CU, CZ, DE, DK, DM, DZ, EC, EE, EG, ES, FI, GB, GD,
GE, GH, GM, HR, HU, ID, IL, IN, IS, JP, KE, KG, KP, KR,
KZ, LC, LK, LR, LS, LT, LU, LV, MA, MD, MG, MK, MN,
MW, MX, MZ, NI, NO, NZ, OM, PG, PH, PL, PT, RO, RU,
SC, SD, SE, SG, SK, SL, SY, TJ, TM, TN, TR, TT, TZ, UA,
UG, UZ, VC, VN, YU, ZA, ZM, ZW.

(84) Designated States (*regional*): ARIPO patent (BW, GH,
GM, KE, LS, MW, MZ, SD, SL, SZ, TZ, UG, ZM, ZW),
Eurasian patent (AM, AZ, BY, KG, KZ, MD, RU, TJ, TM),
European patent (AT, BE, BG, CH, CY, CZ, DE, DK, EE,
ES, FI, FR, GB, GR, HU, IE, IT, LU, MC, NL, PT, RO, SE,
SI, SK, TR), OAPI patent (BF, BJ, CF, CG, CI, CM, GA,
GN, GQ, GW, ML, MR, NE, SN, TD, TG).

Published:

- with international search report
- before the expiration of the time limit for amending the claims and to be republished in the event of receipt of amendments

(88) Date of publication of the international search report:
29 July 2004

For two-letter codes and other abbreviations, refer to the "Guidance Notes on Codes and Abbreviations" appearing at the beginning of each regular issue of the PCT Gazette.

(54) Title: RADIO FREQUENCY IDENTIFICATION DEVICE FORMED IN A NON-METALLIZED REGION WITH AN ANTENNA CONNECTED TO AN OUTSIDE METALLIZED REGION, AND METHOD OF MANUFACTURING

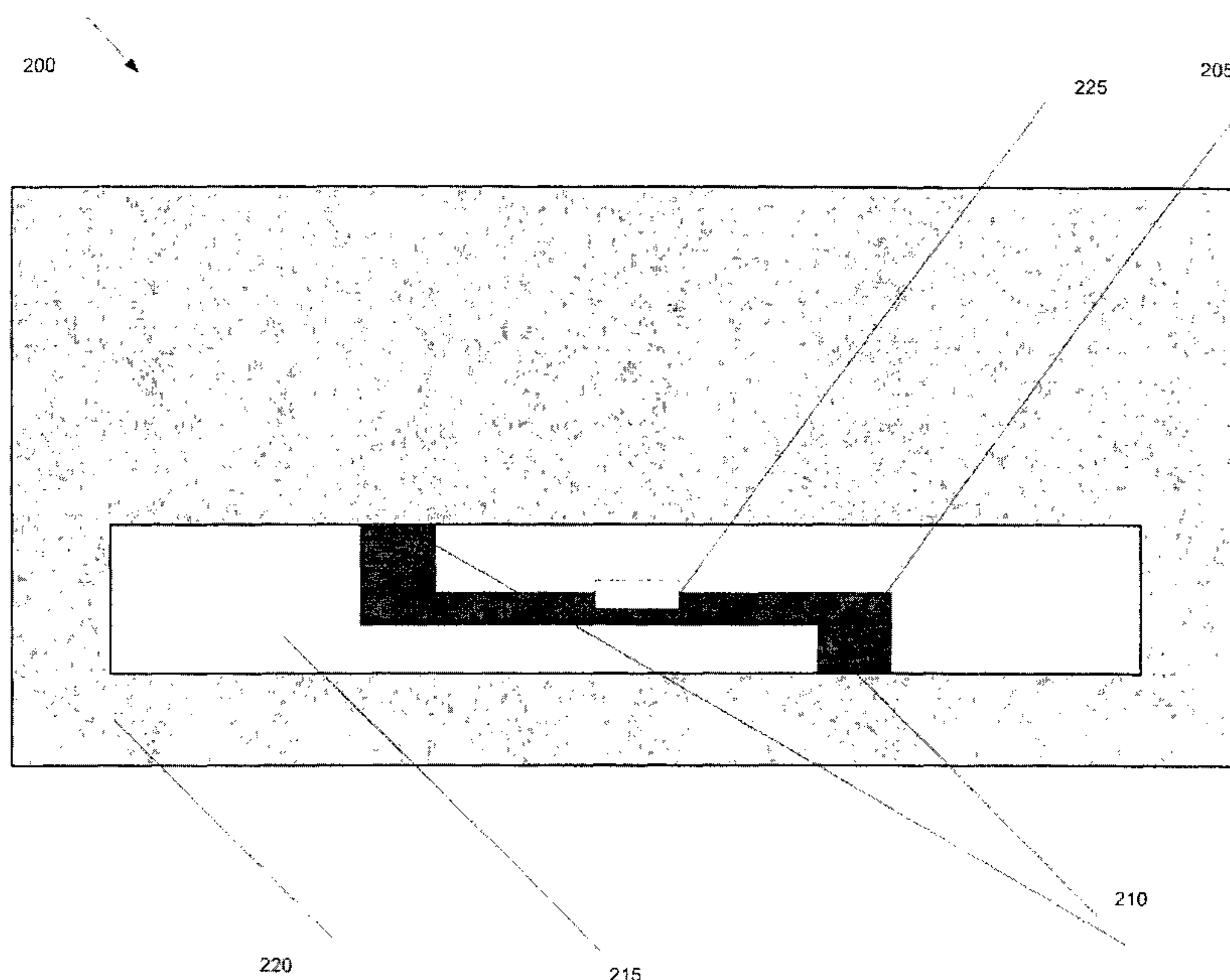

(57) Abstract: The present invention provides systems and methods for transmitting and receiving information from a radio frequency (RF) transponder. A conductive adhesive (210) connects an antenna (205) in a non-metallized region (215) to a metallized region (220). This feature transforms the entire metallized region of the radio frequency device (*i.e.*, the remainder of the metallized material outside the non-metallized region) into an antenna.

WO 2004/047906 A3

TITLE OF THE INVENTION**SYSTEM AND METHOD FOR PROVIDING SECURE IDENTIFICATION SOLUTIONS UTILIZING A RADIO FREQUENCY DEVICE IN A NON-METALLIZED REGION CONNECTED TO A METALLIZED REGION**

5 This application claims priority to U.S. Provisional Patent Application Serial No. 60/428,257 filed November 22, 2002. The entirety of that provisional application is incorporated herein by reference.

 The application incorporates by reference: U.S. Patent Application Serial No. 10/636,732, filed August 8, 2003; U.S. Patent Application Serial No. 10
10 10/615,026, filed July 9, 2003; U.S. Patent Application Serial No. 10/118,092, filed April 9, 2002; PCT Patent Application PCT/IB02/01439, filed April 30, 2002; German Patent Application No. 10121126.0, filed April 30, 2001; Mexican Patent Applications No. 010967, filed October 26, 2001, No. 010968, filed October 26, 2001, No. 010969, filed October 26, 2001, No. 010971, filed October 26, 2001,
15 No. 003141, filed March 25, 2002, and No. 003202, filed March 26, 2002.

Field of the Invention

 The present invention relates generally to a system and method for providing secure identification solutions, and specifically to a system and method for providing secure identification solutions utilizing devices with radio frequency
20 (RF) transponders.

BRIEF DESCRIPTION OF THE FIGURES

 Figures 1 and 2 illustrate RF devices 100 and 200, according to two embodiments of the present invention.

 Figure 3 illustrates a method of making 300, according to one embodiment
25 of the present invention.

 Figure 4 illustrates a method of use 400 of use of the RF device described above, according to one embodiment of the present invention.

DESCRIPTION OF THE INVENTION

The present invention provides systems and methods for transmitting and receiving information from a radio frequency (RF) device (e.g., an RF transponder). A conductive adhesive connects an antenna in a non-metallized region to a metallized region. This feature transforms the entire metallized region of the RF device (*i.e.*, the remainder of the metallized material outside the non-metallized region) into an antenna. This enables greater reading distance and greater data capacity.

In one embodiment, the non-metallized region is a formerly metallized region that has been demetallized. A metal foil substrate which remains following the demetallization process is converted into an antennal surface. This antennal surface captures power as a parabolic or increased area, rather than allowing the metal foil substrate to interfere.

Connection of the antenna to the metallized region can take place in a variety of areas. The following description sets forth two possible attachment configurations (e.g., connections on the sides, connections on the top and bottom), but those experienced in the art will see that multiple other attachment configurations are possible.

The present invention utilizes the following features: passive transponder systems; and retro-reflective, holographic, and other metallic materials.

Passive Transponder Systems. Passive transponder systems are used worldwide for many identification purposes. A passive transponder system is powered by an electromagnetic field of a reader. (No power supply is within the transponder.) A transponder is a transceiver (*e.g.*, a transmitter/receiver that both transmits and receives signals) in a communication satellite that receives a signal from an earth station and retransmits it on a different frequency to one or more other earth stations. An internal antenna of the transponder is used for both data transmission and energy transmission between the reader and the transponder, using, for example, the same frequency for the data and energy transmissions.

Retro-Reflective, Holographic, and Other Metallic Materials. Retro-

reflective materials can reflect and re-emit incident light in a direction that is parallel to that of the source of the incident light. In other words, retro-reflective materials reflect light directly back toward the source of the light. Such materials and devices are widely used in the areas of nighttime transportation and safety. For example, retro-reflective materials are used to illuminate highway lanes and road signs using the light emitted from vehicle headlights. Retro-reflective materials are also used for the production of plates and decals for vehicles and for truck containers, tractors and other applications. Retro-reflective materials have a bright effect under direct light without disturbing human sight.

10 Holographic materials have also been used for identification purposes. Since holograms are difficult to counterfeit, they are increasingly used for identification purposes (*e.g.*, driver's licenses, credit cards, bus passes, etc.) to increase security.

15 Both retro-reflective and holographic materials typically contain a very high level of metal such as aluminum. Holograms, for example, are typically stamped from metal foils. It is known that metal blocks the transmission and reception of RF signals because the RF signal is absorbed or distorted by the metal content in the material. As a result, the signal cannot be received by an antenna blocked by metal. Such a blocked signal cannot be used, for example, to activate a connected device. This same blocking effect can occur whether the device is positioned on top of or underneath the metallic material because the distortion and absorption of the RF signal will be affected in either case.

The RF Device

25 In one embodiment of the invention, as described further, for example, in U.S. Provisional Patent Application Serial No. 60/394,241, filed July 9, 2002, and the corresponding utility U.S. Patent Application Serial No. 10/615,026, filed July 9, 2003, a system for delivering security solutions is provided that includes one or more of the following: a radio frequency (RF) device; and an identification mechanism (*e.g.*, a card, sticker, device). According to another embodiment of the present invention, as described further in these applications, the RF device includes

30

retro-reflective, holographic, or other material containing metal, and an antenna for receiving radio frequency (RF) signals.

As explained above, in one embodiment of the present invention, an entire metallized region of an RF device is transformed into an antenna by connecting an antenna in a non-metallized region to a metallized region, allowing for greater reading distance and greater data accuracy. Connecting the antenna in the non-metallized region to the metallized region also aids in overcoming transmission problems created by metallic materials.

Figure 1 illustrates an RF device 100, according to one embodiment of the present invention. The RF device 100 comprises: a metallized region 110 (e.g., a retro-reflective, holographic, or other metal material), a non-metallized region 115 (e.g., a demetallized region), an antenna 120, a chip 125, and a connection 130 (e.g., a conductive adhesive). An optional holographic image is included in the non-metallized region. An optional liner 105 is used as a base layer to carry the adhesive into the label.

The metallized region 110 comprises, for example, the following materials: Retro-Reflective, Holographic, and metallized covers. The non-metallized region 115 comprises, for example, the following materials: PET, PVC, Polypropylene, vinyl. The antenna 120 comprises, for example, the following materials: conductive inks, aluminum, etc. The chip 125 (e.g., Picorypt made by Inside Technologies, Sahara made by BNC US Holding, San Diego, California, or any RF chip) comprises control logic for controlling the RF signal and for Analog to Digital or Digital to Analog conversion. The connection 130 comprises, for example, the following materials: gold and/or silver bumps. The holographic image comprises, for example, the following materials: Aluminum. The base layer comprises, for example, the following materials: PET, PVC, Polypropylene, vinyl. The connection 130 connects *the sides of the antenna* 120 in the non-metallized region 115 to the metallized region 110. The antenna 120 is thus in electrical communication (*i.e.*, electronically coupled) with the chip 125. In one embodiment

of the present invention, the non-metallized region 115 has been selectively demetallized such that the chip 125 can transmit and receive information.

Figure 2 illustrates an RF device 200, according to one embodiment of the present invention. The RF device 200 comprises: a metallized region 220 (*e.g.*, a retro-reflective, holographic, or other metallic material), a non-metallized region 215, an antenna 205, a chip 225, and a connection 210 (*e.g.*, a conductive adhesive). The components of device 200, in one embodiment, are made of material similar to that described above with reference to Figure 1. The connection 210 connects *a portion of the top and bottom of the antenna 205* in the non-metallized region 215 to the metallized region 210. The antenna 220 is in electrical communication with the chip 225.

Method of Making the RF Device

Figure 3 illustrates an overview of a method of making 300, according to one embodiment of the present invention. A method of making an RF device comprising a base layer and at least one metal region disposed thereon is illustrated. In step 305, a first metal region of the device is selectively demetallized to create a non-metallized region. The process of demetalization comprises covering the parts that are not wanted for demetalization with a protective layer of indelible inks, afterwards, the material is placed in a solution of ferric chloride and hydrochloric acid, which will remove the whole metallic material that has not been protected. Then, the material is washed to eliminate the residual acid and the protective inks. The conductivity of the material is measured for quality control, and to assure that the metallized material will be suitable for use as an antenna for the Radio Frequency device. In step 310, a holographic image is formed on the non-metallized region. To make a holographic image, a beam of laser light is optically separated into two beams. One, the reference beam, is directed toward a piece of holographic film and expanded (its diameter increased) so that the light covers the film evenly and completely. The second (object) beam is directed at the subject of the composition and similarly expanded to illuminate it.

When the object beam reflects off the subject, it carries with it information about the location, size, shape and texture of the subject. Some of this reflected object beam then meets the reference beam at the holographic film, producing an interference pattern which is recorded in the light sensitive emulsion.

5 Embossed holograms are holograms with a mirror backing. Embossing is the most frequently used method of mass-production in holography. The holographic information is transferred from light sensitive glass plates to nickel embossing shims. The holographic images are "printed" by stamping the interference pattern onto plastic and then backing the images with a light reflecting
10 foil. The resulting hologram can be duplicated millions of times. In step 315, an antenna is formed on the base layer. In step 320, an RF chip is mounted on the base layer in electrical communication with the antenna to form an RF transponder.

In step 325, the antenna in the non-metallized region is connected to the metallized region with a connector (*e.g.*, a conductive adhesive).

15 **Example Use of the RF Device**

Figure 4 illustrates a method of use 400 of RF device 100 and/or 200, according to one embodiment of the present invention. In this case, the RF device is a window sticker 405 displayed on a vehicle 410. As the vehicle passes an RF reader 415 (*e.g.*, a U519 reader manufactured by BNC US holding, San Diego,
20 California) the information from the RF device is read. In one embodiment, an RF reader/writer is used, and information is read and written to and from the RF device. As will be apparent to those skilled in the relevant art(s) after reading the description herein, the window sticker is merely one illustration of the multiple uses of an RF device, and that the present invention is not limited to this
25 embodiment. Other example uses of the RF device are: a passport, a driver's license, a license plate or other vehicle identification mechanism, a sticker, and a cell phone.

Conclusion

The present invention is described in terms of the above embodiments.
30 This is for convenience only and is not intended to limit the application of the

present invention. In fact, after reading the description of the present invention or upon learning by practice of the invention, additional advantages, features, and embodiments of the invention will be apparent to one skilled in the relevant arts.

5 In addition, it should be understood that the Figures described above, which highlight the functionality and advantages of the present invention, are presented for example purposes only. The architecture of the present invention is sufficiently flexible and configurable, such that it may be utilized in ways other than that shown in the Figures.

WHAT IS CLAIMED IS:

1. A radio frequency device comprising:
at least one metallized region;
at least one non-metallized region;
5 at least one antenna on the at least one non-metallized region;
at least one radio frequency chip in communication with the at least one
antenna; and
at least one connector connecting the at least one antenna to the at least one
metallized region.
- 10 2. The radio frequency device of Claim 1, further comprising:
at least one base layer.
3. The radio frequency device of Claim 2, wherein the at least one
metallized region is disposed on the at least one base layer.
4. The radio frequency device of Claim 1, wherein the at least one non-
15 metallized region is created by demetallizing a portion of the at least one metallized
region.
5. The radio frequency device of Claim 1, further comprising at least one
holographic image.
6. The radio frequency device of Claim 5, wherein the at least one
20 holographic image is in the at least one non-metallized region.
7. A radio frequency device comprising:
at least one base layer;
at least one metallized region disposed on the at least one base layer;
at least one non-metallized region;
25 at least one antenna on the at least one non-metallized region;
at least one radio frequency chip on the at least one base layer in
communication with the at least one antenna; and
at least one connector connecting the at least one antenna to the at least one
metallized region.

8. The radio frequency device of Claim 7, further comprising at least one holographic image.

9. The radio frequency device of Claim 7, wherein the at least one holographic image is in the at least one non-metallized region.

5 10. The radio frequency device of Claim 7, wherein the at least one non-metallized region is created by demetallizing a portion of the at least one metallized region.

11. A radio frequency device comprising:

at least one base layer;

10 at least one metallized region disposed on the at least one base layer;

at least one non-metallized region;

at least one holographic image;

at least one antenna on the at least one non-metallized region;

at least one radio frequency chip in the at least one base layer in

15 communication with the at least one antenna; and

at least one connector connecting the at least one antenna to the at least one metallized region.

12. The radio frequency device of Claim 11, wherein the at least one holographic image is in the at least one non-metallized region.

20 13. The radio frequency device of Claim 11, wherein the at least one non-metallized region is created by demetallizing a portion of the at least one metallized region.

14. A radio frequency device comprising:

at least one base layer;

25 at least one metallized region disposed on the at least one base layer;

at least one non-metallized region;

at least one holographic image on the at least one non-metallized region;

at least one antenna on the at least one non-metallized region;

at least one radio frequency chip in the at least one base layer in

30 communication with the at least one antenna; and

at least one connector connecting the at least one antenna to the at least one metallized region.

15 15. The radio frequency device of Claim 14, wherein the at least one non-metallized region is created by demetallizing a portion of the at least one metallized region.

16. A radio frequency device comprising:
at least one base layer;
at least one metallized region disposed on the at least one base layer;
at least one non-metallized region;
10 at least one holographic image in the at least one non-metallized region;
at least one antenna on the at least one non-metallized region;
at least one radio frequency chip on the at least one base layer in communication with the at least one antenna; and
at least one connector connecting the at least one antenna to the at least one
15 metallized region; and
whereby the at least one non-metallized region is created by demetallizing a portion of the at least one metallized region.

17. A method of making a radio frequency device, comprising:
forming at least one metallized region;
20 forming at least one non-metallized region;
forming at least one antenna on the at least one non-metallized region;
mounting at least one radio frequency chip in communication with the antenna; and
connecting the antenna in the non-metallized region to the metallized region
25 with a connector.

18. The method of Claim 17, further comprising forming at least one base layer.

19. The method of Claim 17, further comprising forming at least one holographic image.

20. The method of Claim 19, wherein the holographic image is formed on the at least one non-metallized region.

21. The method of Claim 17, wherein the non-metallized region is created by demetallizing a portion of the at least one metallized region.

5 22. A method of making a radio frequency device, comprising:
forming at least one base layer;
forming at least one metallized region disposed on the at least one base
layer;
forming a non-metallized region;
10 forming an antenna on the non-metallized region;
mounting a radio frequency chip in electrical communication with the
antenna; and
 connecting the antenna in the non-metallized region to the metallized region
with a connector.

15 23. The method of Claim 22, further comprising forming a holographic
image in the non-metallized region.

24. The method of Claim 22, wherein the non-metallized region is created
by demetallizing a portion of the at least one metallized region.

20 25. A method of making a radio frequency device, comprising:
forming at least one base layer;
forming at least one metallized region disposed on the at least one base
layer;
forming a non-metallized region;
forming a holographic image in the non-metallized region;
25 forming an antenna in the non-metallized region;
mounting a radio frequency chip in electrical communication with the
antenna; and
 connecting the antenna in the non-metallized region to the metallized region
with a connector.

26. The method of Claim 25, wherein the non-metallized region is created by demetallizing a portion of the at least one metallized region.

27. A method of making a radio frequency device, comprising:

forming at least one base layer;

5 forming at least one metallized region disposed on the at least one base layer;

forming at least one non-metallized region;

forming at least one holographic image in the at least one non-metallized region;

10 forming at least one antenna in the at least one non-metallized region;

mounting at least one radio frequency chip in communication with the at least one antenna; and

connecting the at least one antenna in the at least one non-metallized region to the at least one metallized region with a connector;

15 whereby the at least one non-metallized region is created by demetallizing a portion of the at least one metallized region.

FIGURE 1

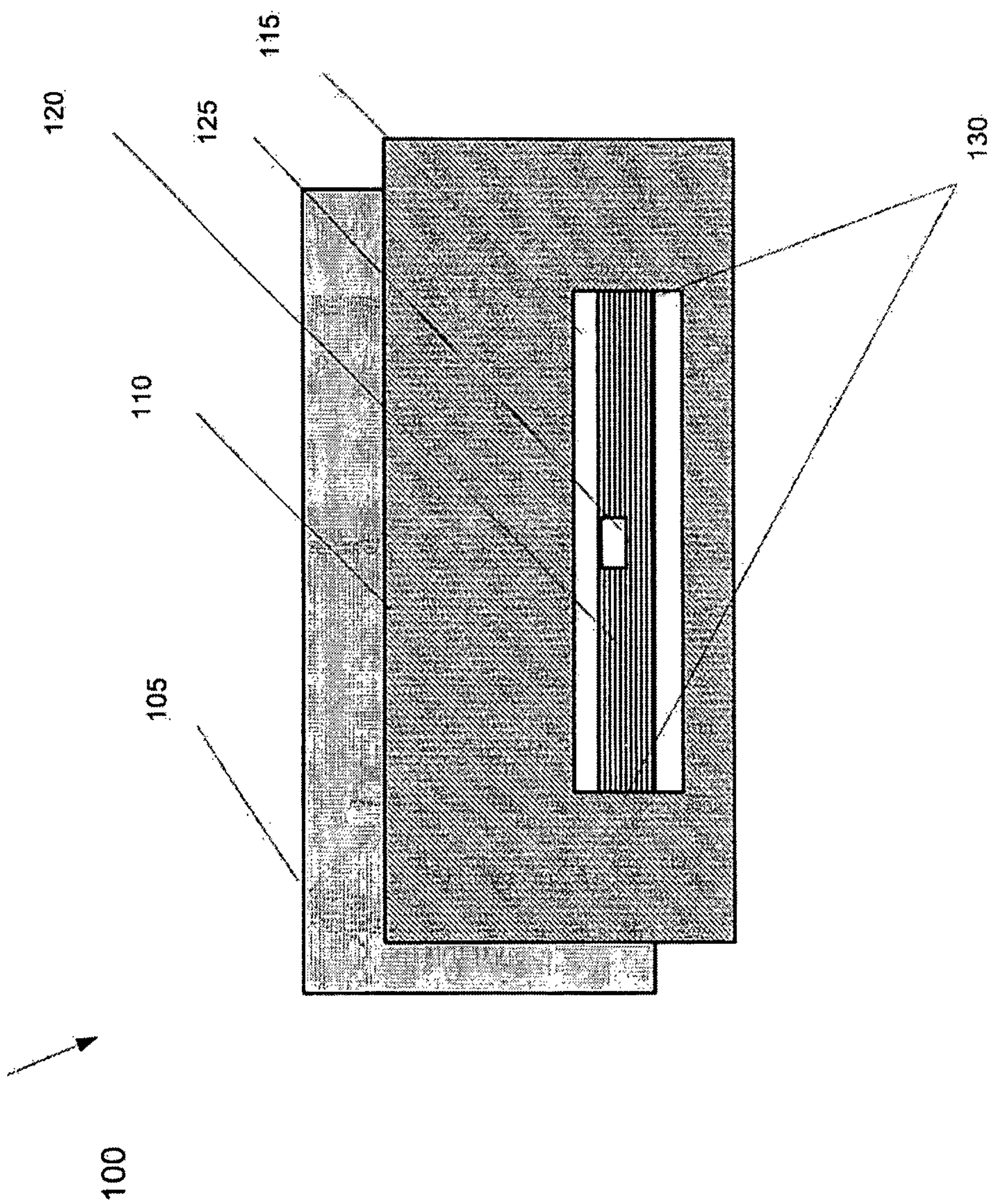

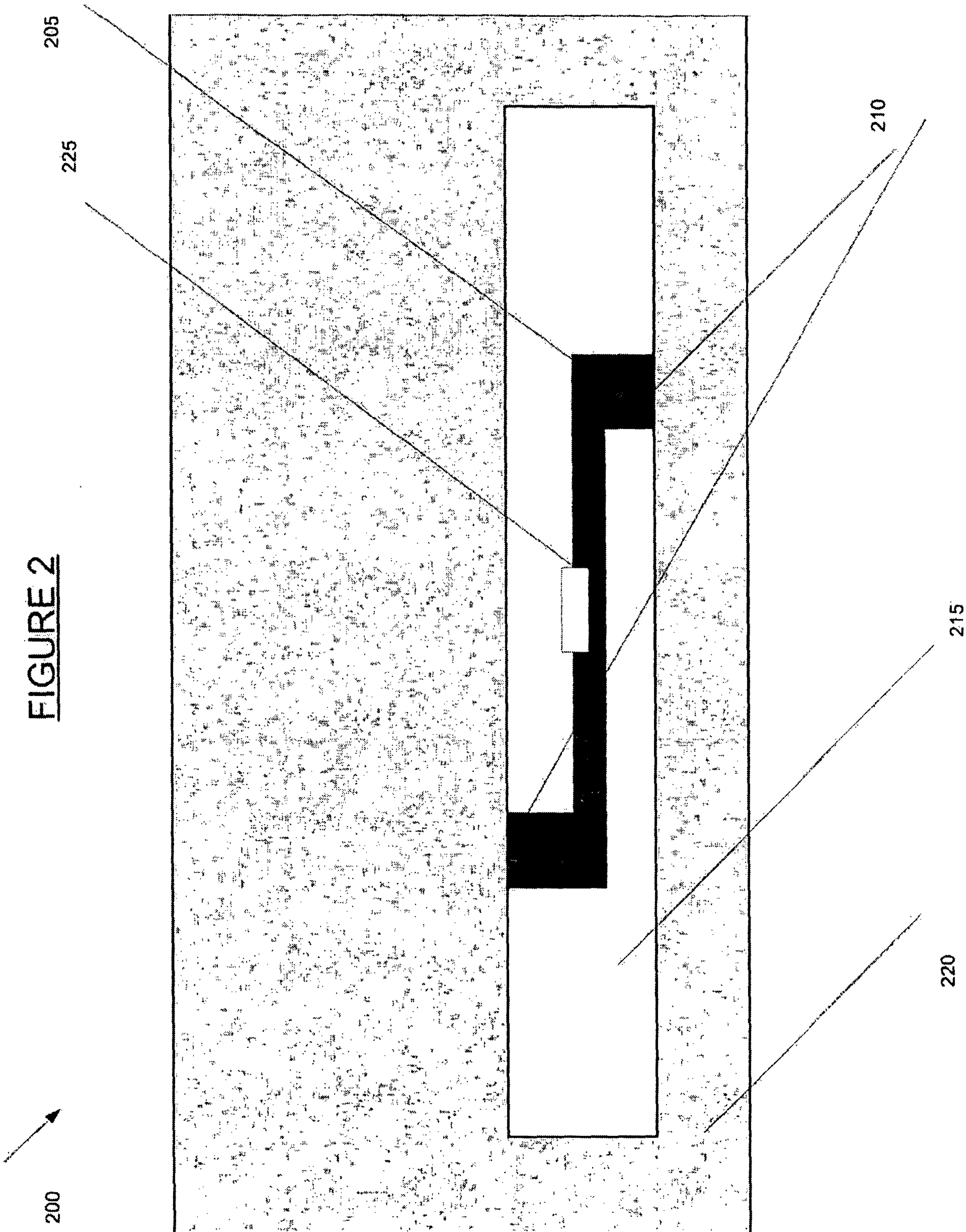

FIGURE 2

FIGURE 3

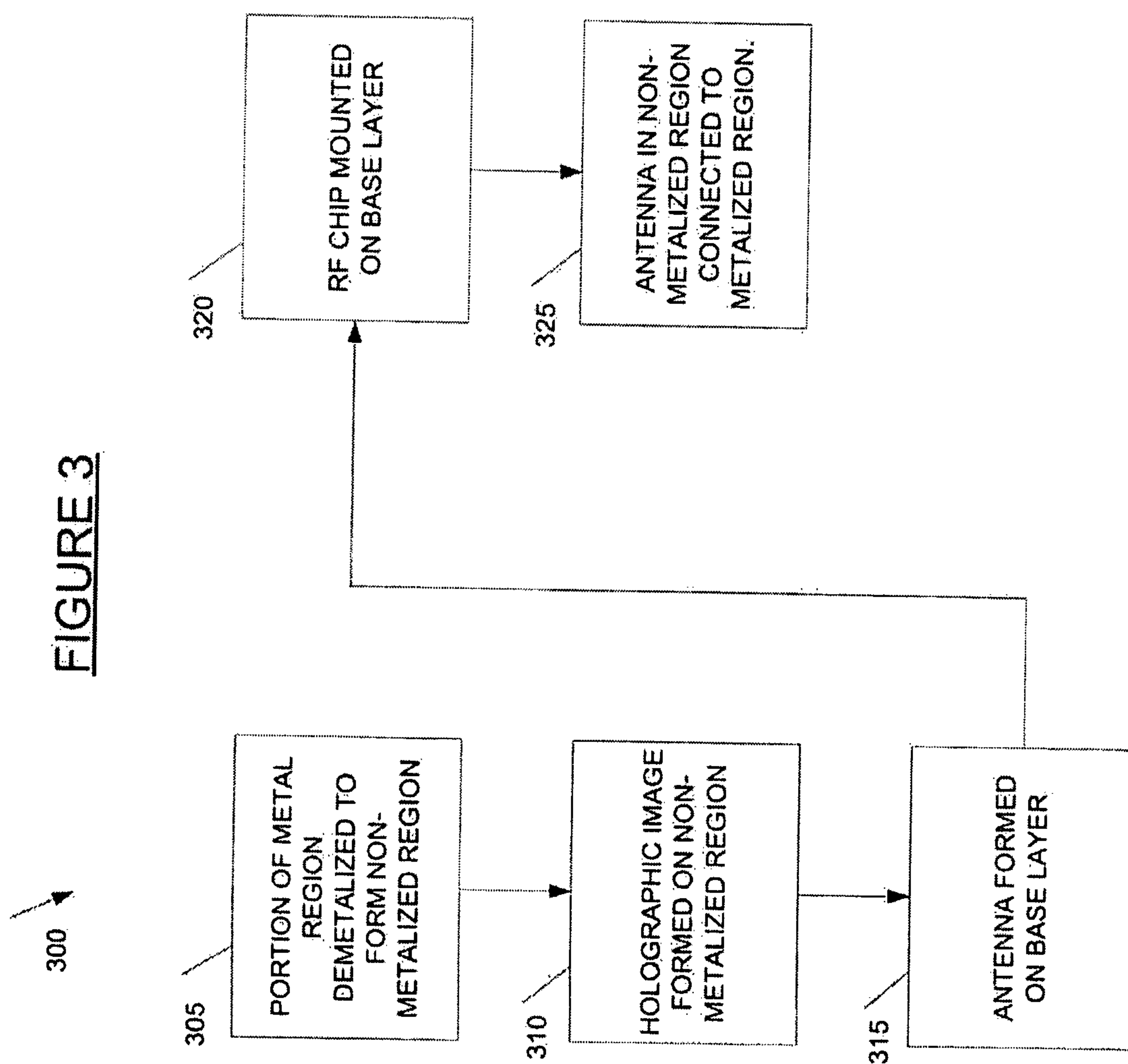
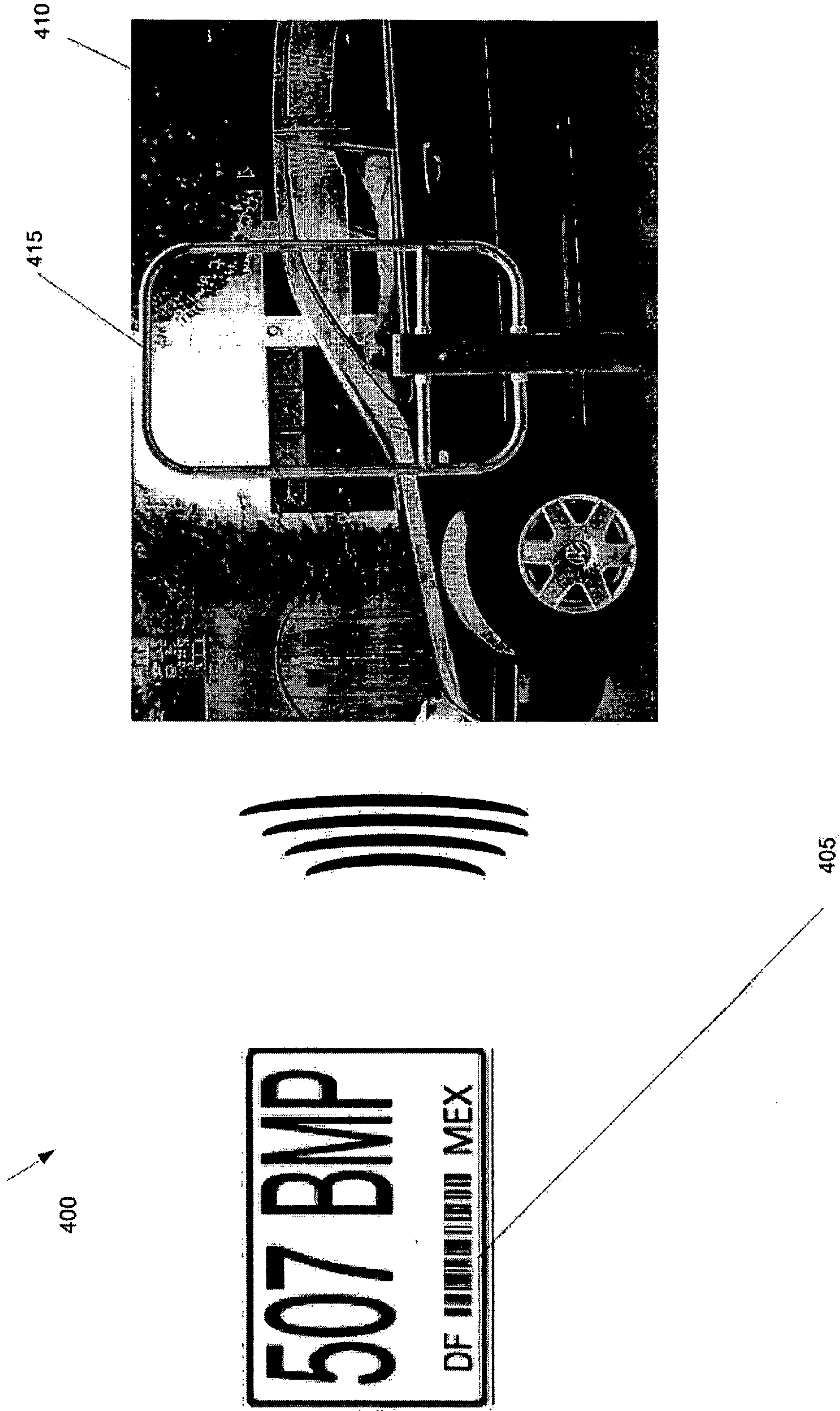

FIGURE 4



200



225

205

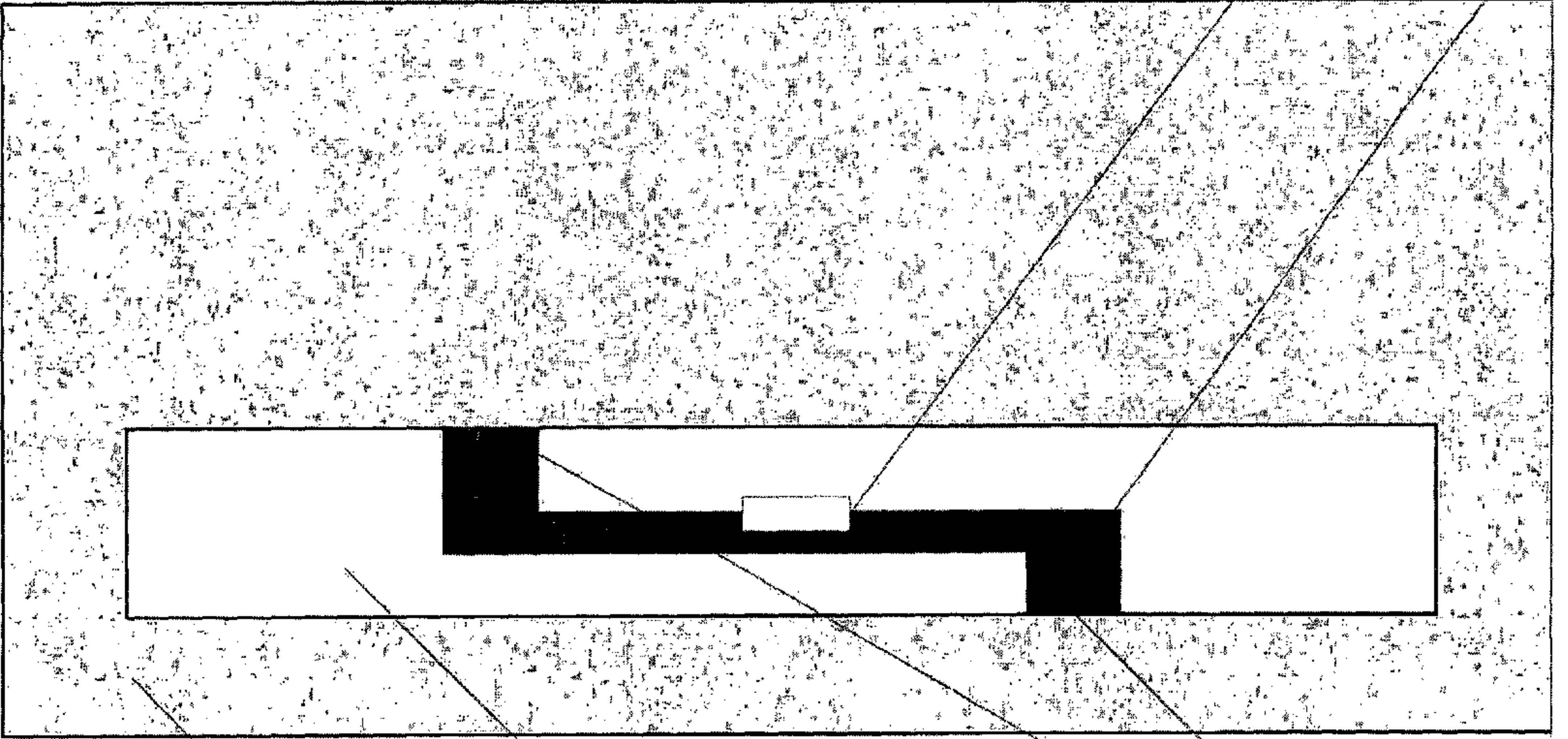

210

220

215