

A. TROVATON.
BOLSTER SPRING.

(Application filed June 27, 1901.)

(No Model.)

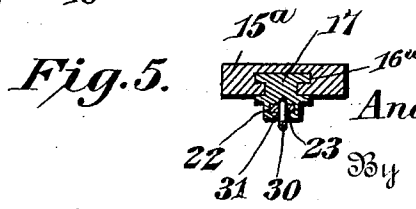
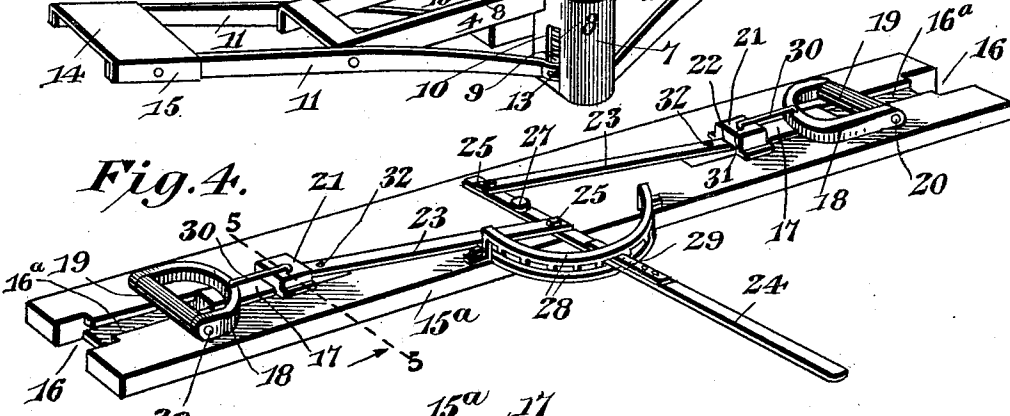
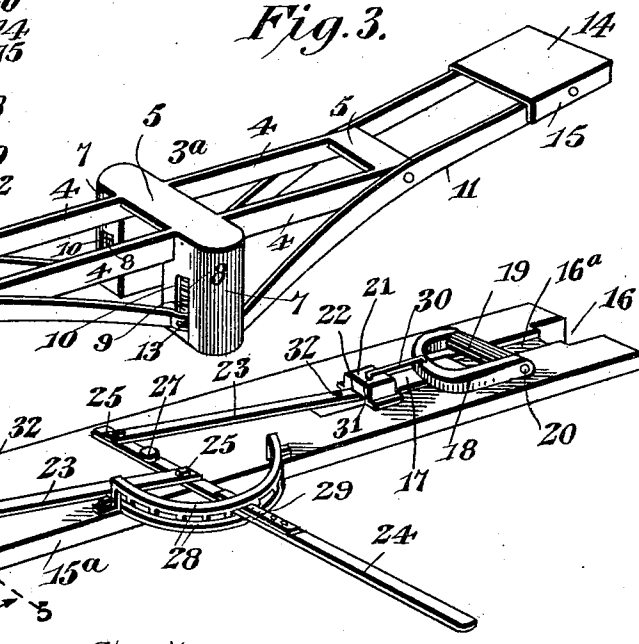
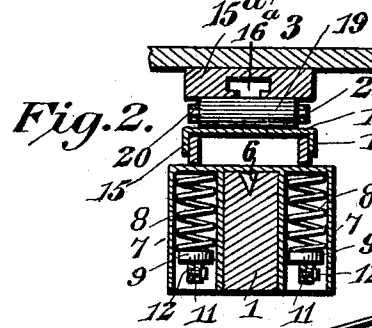
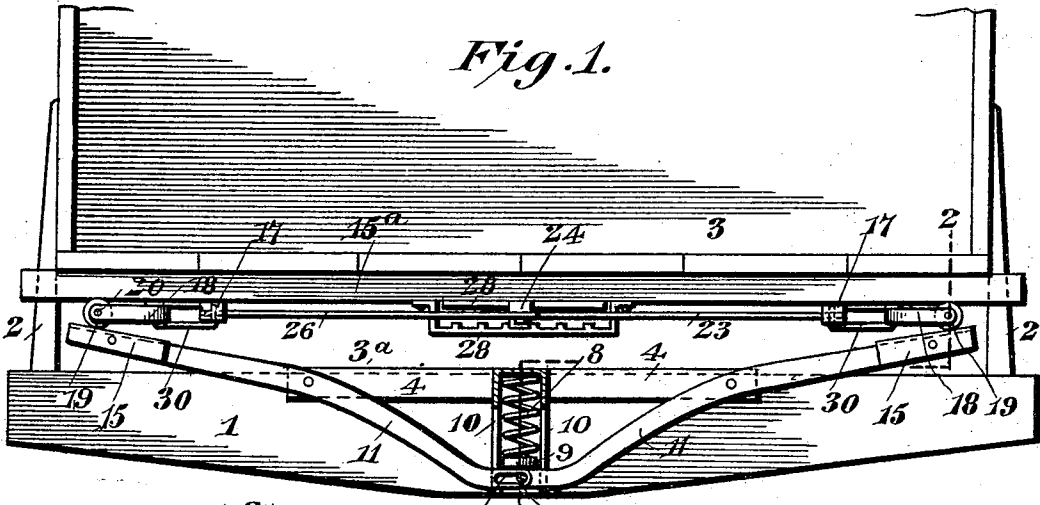

Andrew Trovaton, Inventor.

Witnesses:
Jas. K. McLaughlin
R. H. Elliott.

E. J. Siggers
Attorney.

UNITED STATES PATENT OFFICE.

ANDREW TROVATON, OF MCINTOSH, MINNESOTA.

BOLSTER-SPRING.

SPECIFICATION forming part of Letters Patent No. 682,002, dated September 3, 1901.

Application filed June 27, 1901. Serial No. 66,283. (No model.)

To all whom it may concern:

Be it known that I, ANDREW TROVATON, a citizen of the United States, residing at McIntosh, in the county of Polk and State of Minnesota, have invented a new and useful Bolster-Spring for Vehicles, of which the following is a specification.

This invention relates generally to vehicle-springs, and more particularly to that class known as "bolster-springs," which are associated with the bolster of the vehicle and present a spring-support for the body or bed of the vehicle.

The present invention is designed as an improvement upon a spring-support for vehicles constituting the subject-matter of an application for United States patent filed by me September 8, 1900, Serial No. 29,457, and more particularly to the means for varying the leverage of the supporting-levers for the vehicle body or bed, according to the load within the wagon.

In the application referred to the means for varying the leverage of the supporting-levers comprises swinging bails carrying rollers constituting rests, the bails having an adjustable connection with the supporting-levers, the change of leverage being effected by swinging the rollers to or from the extremities of said arms or by disengaging the bails from one set of openings in the arms and engaging them with another set of openings. While this arrangement is highly effective in operation and by reason of its simplicity of construction and efficiency and durability has been found practical and satisfactory in use, yet owing to the fact that to effect a change in the leverage of the supporting-arms a wagon-body had to be raised it has been found objectionable under some conditions of use.

The object of the invention is to produce a simple and thoroughly efficient means by which the leverage of the supporting-levers may be quickly varied under all conditions of use without necessitating the lifting of the wagon-body and in which such adjustment may be accomplished equally well with a loaded or unloaded wagon.

A further object is to simplify the construction of and, without adding material

thereto, to increase the strength of the supporting-levers.

A further object is to provide a wider range of adjustment of the roller-rests than that presented by the arrangement of mechanism shown in the application referred to whereby to vary the leverage of the supporting-levers to suit any load carried by the wagon.

With these and other salient objects in view, as will appear in the further presentation of the case, the invention consists in the novel construction and combination of parts of a spring-support for vehicles, as will be hereinafter fully described and claimed.

In the accompanying drawings, forming a part of this specification, and in which like numerals of reference indicate corresponding parts, I have illustrated a form of embodiment of my invention exhibiting one manner in which the salient ideas thereof may be carried into effect, it being understood that the construction and arrangement of the parts herein shown may be changed or altered as to shape and disposition with relation to each other without departing from the spirit of the invention.

In the drawings, Figure 1 is a view in elevation, partly in section, of a spring-support for vehicles embodying the essential features of the present invention, having associated therewith the bolster of a vehicle and the body or bed of a wagon. Fig. 2 is a view in transverse section, taken on the line 2 2 of Fig. 1. Fig. 3 is a detail perspective view of the spring-support or bolster-spring, the rest-bar being omitted. Fig. 4 is a view in perspective of the rest-bar, showing the mechanism carried thereby. Fig. 5 is a transverse sectional view taken on the line 5 5 of Fig. 4.

The device of the present invention is adaptable for use in connection with any form of vehicle employing the usual bolster, and in the present instance is shown as applied to an ordinary box-bodied vehicle, in which designates the ordinary bolster carrying at each end the usual standard 2, between which is arranged the wagon body or bed 3, the same being adapted for vertical movement between the said standards.

The spring-support comprises in part a bolster-saddle 3^a, which is adapted to strad-

5 dle the upper edge of the bolster and to have
 a firm support thereon and to be readily de-
 detachable therefrom. The form of saddle
 herein shown is one that will generally be
 10 employed; but it is to be distinctly under-
 stood that the precise form herein illustrated
 may be changed or altered in many respects
 and still be within the scope of the present
 invention. The bolster-saddle comprises, in
 15 part, a skeleton casting, composed of parallel
 side arms or flanges 4, adapted in use to bear
 against the opposite sides of the bolster, the
 arms being connected by cross-plates or webs
 5, of which three are shown in this instance,
 20 it being understood that this number may be
 increased without departing from the spirit
 of the invention, the cross-plates by prefer-
 ence to be formed integral with the side arm;
 but, if preferred, they may be made separate
 25 therefrom and be suitably associated there-
 with. By arranging the cross-plates in the
 manner illustrated the saddle is open at its
 lower side, so as to fit over the bolster, as
 clearly shown in Fig. 1, and as a means for
 30 preventing the saddle from shifting on the
 bolster any suitable fastening means may be
 employed, as bolts, screws, or the like, these
 to pass through the end cross-plates and into
 the bolster, or instead of the employment of
 35 screws or bolts these end plates may be pro-
 vided each with one or more prongs or spurs 6
 to be driven into the upper side of the bol-
 ster, these to hold the saddle in place thereon.

Carried by and preferably formed integral
 35 with the central cross-plate and on diametric-
 ally opposite sides of the saddle are two pend-
 ent tubular casings 7, these casings to be of
 a length practically equal to the height of the
 bolster, so that when the saddle is placed on
 40 the bolster these casings will serve to cause a
 firmer union between the saddle and the bol-
 ster. Each casing is closed at its top by the
 center cross-plate and each houses a coiled
 spring 8, the upper end of which bears against
 45 the said cross-plate and the lower end of each
 spring against a head or plate 9, which is of
 a size to work easily in the bore of the casing.
 Each casing has on each side and in longitu-
 dinal alinement a slot 10, into which project
 50 the inner slidable interlocked ends of sup-
 porting-levers 11, arranged on opposite sides
 of and pivotally connected with the side arms
 4 of the bolster-saddle. These levers are by
 preference arranged in parallel relation to
 55 each other and are of segmental or arcuate
 shape, thus to curve upward and outward
 from a point beneath the upper face of the
 saddle to a point sufficiently elevated above
 the plane of such face as to present the req-
 60 uisite space for the proper vertical move-
 ment of the wagon-body under the varying
 conditions of its load. The ends of the le-
 vers which project through the slots 10 are,
 as stated, interlocked, and the means of con-
 65 nection between the parts in this instance
 consists of a pin 12, carried by the end of
 one of the arms and engaging a slot 13 in the

end of the other arm, and by this simple ar-
 rangement the inner ends of the levers will
 be free to have the requisite vertical move- 70
 ment to permit the outer ends of the levers
 to swing through the required arc occasioned
 by the weight of the load in the wagon-body.
 The outer portion or end of each pair of le- 75
 vers is connected by a plate 14, which, as
 shown in Fig. 3, may have side flanges 15 to
 be secured to the ends of the levers or, if
 preferred, this plate may be cast integral
 with the levers, and from the standpoint of
 simplicity of construction and cheapness of 80
 production the plate generally will be cast
 integral with the levers. With the excep-
 tion of the plate at the end of the support-
 ing-levers just described all of the parts of
 the device are in all essential respects con- 85
 structed in the same manner as that shown
 and described in the application referred to.

Arranged above the supporting-levers is a
 rest-bar 15^a, the same being provided at its
 ends with notches 16 to straddle the stand- 90
 ards 2, and thereby to be guided in vertical
 movement thereon. The rest-bar is provided
 near each outer end on its under side with a
 T-shaped groove 16^a, to be engaged by two
 similarly-shaped guides 17, each guide carry- 95
 ing a yoke 18, between the arms of which is
 pivotally mounted a roller 19 to bear upon
 the upper side of the plate 14. Each yoke 18
 is to be associated with its corresponding
 guide 17 in any preferred manner, and from 100
 a standpoint of simplicity of construction and
 efficiency in operation it is preferred to cast
 the yoke integral with the guide, the roller
 19 being held associated with the arms of the
 yoke by a pin or shaft 20. The inner end of 105
 each guide is provided with a head 21, hav-
 ing extending therethrough a slot or recess 22
 to be engaged by one end of an arm 23, the
 other end of which is pivotally connected with
 a lever 24 by a pin or pivot 25, a second arm 110
 23 being connected with the outer end of the
 lever and engaging the slot 22 in the head of
 the guide on the opposite end of the rest-bar.
 The fulcrum 27 for associating the lever 24
 with the rest-bar is intermediate of the point 115
 of connection of the two arms with the lever,
 and by this arrangement movement of the le-
 ver in one direction will effect projection of
 the yokes outward toward the extremities of
 the rest-bar and movement in the opposite 120
 direction will effect the retraction of the yokes
 toward the center of the rest-bar. To guide
 and hold the lever at any desired point of ad-
 justment, two curved bars 28 are employed,
 these being secured to the rest-bar and being 125
 suitably spaced apart to present a slot in
 which the lever 24 will work, one of the bars
 being provided with teeth to constitute a
 rack-bar to be engaged by a spring-arm 29,
 carried by the lever, and by coaction between 130
 this spring-arm and the rack-plate the lever
 may be held at any desired adjustment.

It is to be understood that in carrying my
 invention into practice I do not confine my-

self to the precise manner of construction of the yoke, the manner of associating the rest-rollers 19 therewith, nor the precise construction and manner of assemblage of the lever and the arms 23.

In order to diminish the leverage of the supporting-levers—that is to say, to bring the rest-rollers nearer to the center of the rest-bar—I provide means to adjust the yokes with relation to the arms 23 independently of the lever 24, so that without increasing the throw of the lever the rollers may, as stated, be drawn closely to the center of the rest-bar. The means for effecting this result consists of a spring pin or arm 30, having a toe projecting through an opening 31 in the head 21 and into engagement with one of a plurality of openings 32, formed in that end of the arm engaging the slots 22. Of these openings 31 there may be any desired number, three being shown in the present instance, and to effect moving of the yoke to or from the center of the rest-bar without shifting the lever the spring-arm of each yoke is moved out of engagement with the opening in the end of the arm and the yoke then moved in or out, as the case may be, and the arm is then brought into engagement with the appropriate opening in the arm.

When the rest-bar and its attached mechanism is associated with the bolster-saddle and the supporting-levers 11, the rest-rollers 19 bear upon the upper side of the plates 14, and as the rest-bar is depressed through the medium of the weight of the wagon-body and its contained load the rest-bar will be depressed and the rollers 19 travel upon the top of the plates 14. In assembling the device with a wagon or other vehicle the lever 24 is disposed under the body of the wagon, thus to be out of the way, and when it is desired to vary the leverage of the supporting-levers to resist greater strain or compression the lever is moved toward the left, thereby bringing the rest-rollers inward as near to the inner ends of the plates 14 as possible. Now should it be desired to move the rest-levers outward, thereby to render the supporting-levers more responsive to pressure, the lever is moved to the right, thereby moving the rest-rollers as near to the outer ends of the plates 14 as possible, or should it be desired to slightly vary the leverage of the supporting-levers the lever 24 is moved only a slight distance to the right or left, as the case may be.

It is to be of course understood that two sets of this mechanism are employed on each vehicle—one for the front and one for the rear portion of the body—and it will be apparent from the foregoing description that to effect varying of the leverage of the supporting-levers of both sets it will be only necessary to shift the lever 24 in the manner described.

From the foregoing it is thought that the construction, operation, and many advantages of the herein-described invention will

be apparent to those skilled in the art without further description, and it will be understood that various changes in the size, shape, proportion, and minor details of construction may be resorted to without departing from the spirit or sacrificing any of the advantages of the invention.

What I claim is—

1. A spring-support for vehicles comprising a bolster-saddle carrying spring-pressed supporting-levers, and a rest-bar carrying means for varying the leverage of the supporting-levers.

2. A spring-support for vehicles comprising a bolster-saddle carrying spring-pressed supporting-levers, and a rest-bar provided with adjustable rests for engaging the supporting-levers.

3. A spring-support for vehicles comprising a bolster-saddle carrying spring-pressed supporting-levers provided at their outer extremities with bearing-surfaces, a rest-bar having roller-rests engaging the said surfaces, and means for adjusting the roller-rests with relation to the bearing-surfaces, whereby to increase or diminish the leverage of the supporting-levers.

4. The combination with a bolster-saddle carrying spring-pressed supporting-levers, of a rest-bar carrying roller-rests engaging the supporting-levers, and means carried by the rest-bar to adjust the roller-rests with relation to the supporting-levers.

5. The combination with a bolster-saddle carrying spring-pressed supporting-levers, of a rest-bar, guides carried by the rest-bar, roller-rests carried by the guides, and means for shifting the guides.

6. The combination with a bolster-saddle carrying spring-pressed supporting means, of a rest-bar, yoke-bearing guides mounted for longitudinal movement on the rest-bar, roller-rests carried by the yokes, and adjusting means connected with the guides.

7. The combination with a bolster-saddle carrying spring-pressed supporting-levers, of a rest-bar, yoke-bearing guides mounted for longitudinal movement in ways formed in the bar, roller-rests carried by the yokes, a locking-lever, and arms connecting the locking-lever and the guides.

8. The combination with a bolster-saddle carrying spring-pressed supporting-levers, of a rest-bar, yoke-bearing guides mounted for longitudinal movement in the bar, roller-rests carried by the yokes; arms adjustably connected with the guides, and a locking-lever connected with the arms.

9. The combination with a bolster-saddle carrying spring-pressed supporting-levers, of a rest-bar, yoke-bearing guides mounted for movement in the bar, said guides being provided with orificed heads, arms engaging the orifices of the heads and having a plurality of openings, locking means for engaging the openings in the arms, and a locking-lever connected with the arms.

10. The combination with a bolster provided at each end with a standard, a bolster-saddle mounted on the bolster and carrying spring-pressed supporting-levers, a rest-
5 bar having recesses engaging the standards, roller-rests carried by the rest-bar and engaging the supporting-levers, and means for shifting the roller-rests with relation to the supporting-levers.
- 10 11. A spring-support for vehicles comprising a bolster-saddle, spring-pressed supporting-levers mounted on the saddle and having their extremities connected by bearing-plates, and shiftable roller-rests supported on the
15 plates and sliding thereover.
12. In a spring-support for vehicles, a rest-bar carrying roller-rests, and means for adjusting the rests with relation to the rest-bar.
13. In a spring-support for vehicles, a rest-
20 bar carrying roller-rests, means for adjusting the rests with relation to the rest-bar, and means for locking the roller-rests in their adjusted positions.
14. A support of the class described comprising spring-pressed oppositely-disposed
25 supporting-levers, and manually-operated means for varying the leverage of all the levers simultaneously.
15. A support of the class described comprising spring-pressed supporting-levers, 30 roller-rests, and means for shifting the said rests on the levers to vary the leverage thereof.

In testimony that I claim the foregoing as my own I have hereto affixed my signature in the presence of two witnesses.

ANDREW TROVATON.

Witnesses:

E. M. NILES,
HALVER O. TROVATON.