



(51) International Patent Classification:
H05K 7/18 (2006.01)

(21) International Application Number:
PCT/US2014/070553

(22) International Filing Date:
16 December 2014 (16.12.2014)

(25) Filing Language: English

(26) Publication Language: English

(71) Applicant: HEWLETT PACKARD ENTERPRISE DEVELOPMENT LP [US/US]; 11445 Compaq Center Drive West, Houston, TX 77070 (US).

(72) Inventors: POTTER, Andrew; Hewlett-Packard Company, 11445 Compaq Center Drive West, Houston, TX 77070 (US). DELLA FIORA, Troy, A.; Hewlett-Packard Company, 11445 Compaq Center Drive West, Houston, TX 77070 (US). BUNKER, Michael, S.; Hewlett-Packard Company, 11445 Compaq Center Drive West, Houston, TX 77070 (US).

(74) Agents: WEBB, Steven, L. et al.; Hewlett Packard Enterprise, 3404 E. Harmony Road, Mail Stop 79, Fort Collins, CO 80528 (US).

(81) Designated States (unless otherwise indicated, for every kind of national protection available): AE, AG, AL, AM,

AO, AT, AU, AZ, BA, BB, BG, BH, BN, BR, BW, BY, BZ, CA, CH, CL, CN, CO, CR, CU, CZ, DE, DK, DM, DO, DZ, EC, EE, EG, ES, FI, GB, GD, GE, GH, GM, GT, HN, HR, HU, ID, IL, IN, IR, IS, JP, KE, KG, KN, KP, KR, KZ, LA, LC, LK, LR, LS, LU, LY, MA, MD, ME, MG, MK, MN, MW, MX, MY, MZ, NA, NG, NI, NO, NZ, OM, PA, PE, PG, PH, PL, PT, QA, RO, RS, RU, RW, SA, SC, SD, SE, SG, SK, SL, SM, ST, SV, SY, TH, TJ, TM, TN, TR, TT, TZ, UA, UG, US, UZ, VC, VN, ZA, ZM, ZW.

(84) Designated States (unless otherwise indicated, for every kind of regional protection available): ARIPO (BW, GH, GM, KE, LR, LS, MW, MZ, NA, RW, SD, SL, ST, SZ, TZ, UG, ZM, ZW), Eurasian (AM, AZ, BY, KG, KZ, RU, TJ, TM), European (AL, AT, BE, BG, CH, CY, CZ, DE, DK, EE, ES, FI, FR, GB, GR, HR, HU, IE, IS, IT, LT, LU, LV, MC, MK, MT, NL, NO, PL, PT, RO, RS, SE, SI, SK, SM, TR), OAPI (BF, BJ, CF, CG, CI, CM, GA, GN, GQ, GW, KM, ML, MR, NE, SN, TD, TG).

Declarations under Rule 4.17:

- as to the identity of the inventor (Rule 4.17(i))
- as to applicant's entitlement to apply for and be granted a patent (Rule 4.17(ii))

Published:

- with international search report (Art. 21(3))



(54) Title: LATCHING SYSTEM

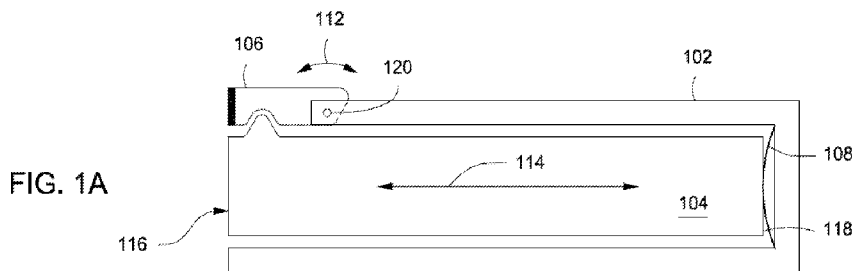

(57) Abstract: In one example a latching system is disclosed. The latching system has a handle that moves along an axis of motion between three positions: a latched position, an unlatched position and an engaged position. The handle moves a retention clip from a locked position into an unlocked position when the handle moves from the unlatched position into the engaged position.

Latching system

BACKGROUND

[0001] Computer servers typically have a plurality of different devices installed into mounts in a rack. The devices may be hard drives, memory cards, solid state memory, processor blades, Input/Output (I/O) cards, network cards or the like. Many of the devices can be added or replaced after the rack has been installed into a data center. Most of the devices use a latching system to hold the device into the mounts in the rack. The latching system typically will physically lock the device into the mount and may provide the correct amount of force to ensure that any electrical connectors on the device are properly inserted into the mating connectors in the mount. The latching system may also provide enough force to disengage the device from the mount when the device is removed.

BRIEF DESCRIPTION OF THE DRAWINGS

- [0002] FIG. 1A is a sectional side view of an example latching system.
- [0003] FIG. 1B is a sectional side view of the example latching system of figure 1 with the handle in the unlatched position.
- [0004] FIG. 2 is a sectional top view of the example latching system of figure 1.
- [0005] FIG. 3 is an isometric top view of an example handle and retention clip.
- [0006] FIG. 4A is an isometric back view (view AA) from figure 3.
- [0007] FIG. 4B is an isometric back view (view AA) from figure 3 with the example engagement features fully engaged.
- [0008] FIG. 5 is a top view of the example handle and retention clip from figure 3.
- [0009] FIG. 6A is a partial view of an example engagement feature.
- [0010] FIG. 6B is a partial view of another example engagement feature.

[0011] FIG. 7 is an isometric front view of an example device.

DETAILED DESCRIPTION

[0012] As the size of devices that are mounted into servers becomes smaller, the space available for the latching systems used to hold them in place is also getting smaller. In addition many of the latching systems used a rotational or camming motion to latch and unlatch the device. Typically the rotational or camming motion required part of the latching system to extend beyond the front face of the device being held in place or to be attached to the front face of the device being held in place.

[0013] In one example, a latching system will use a linear motion of a handle to latch and unlatch the device. The handle will be recessed or flush with the front face of the device when the handle is in the fully latched position. The latching system will mount to the side of the device.

[0014] Figure 1A is a sectional side view of an example latching system. The latching system comprises a frame 102, a handle 104, a handle latch 106, a retention clip 230 (see figure 2) and a leaf spring 108. The handle 104 is slidably mounted to the frame 102 and can move along an axis of motion (as shown by arrow 114). The handle can move between three positions along the axis of motion. The three positions, in order, are a latched position, an unlatched position and an engaged position. The handle is shown in the latched position in figure 1A.

[0015] When the handle 104 is in the latched position, the leaf spring 108 is compressed between the back end 118 of the handle 104 and the frame 102. In some examples, the front face 116 of the handle 104 is flush with the front face of the frame 102 when the handle 104 is in the latched position. In other examples the front face 116 of the handle 104 may be recessed into the frame 102 or extend slightly beyond the front face of the frame 102 when the handle 104 is in the latched position.

[0016] The handle latch 106 is mounted to the frame 102 and can rotate about axis 120 (as shown by arrows 112). The handle latch 106 can rotate between a first position and a second position. When the handle latch 106 is in the first position and the handle

104 is in the latched position, the handle latch 106 holds the handle 104 in the latched position (as shown in fig 1A). When the handle 104 is in the latched position and the handle latch is rotated into the second position, the handle 104 is released and the leaf spring 108 forces the handle 104 into the unlatched position. In this example a leaf spring is used, but other types of springs could be used, for example a compression spring.

[0017] Figure 1B is a sectional side view of the example latching system of figure 1 with the handle in the unlatched position. The handle latch 106 has been rotated into the second position, thereby releasing the handle 104. In some examples the handle latch 106 may be biased towards the first position, for example by a spring. The leaf spring 108 has forced the handle 104 along the axis of motion 114 into the unlatched position. In the unlatched position the front face 116 of the handle 104 extends beyond the front edge of the frame 102 by distance d1. In some examples distance d1 is between $\frac{1}{4}$ of an inch and 1 inch, for example $\frac{1}{2}$ an inch.

[0018] Once the handle 104 is in the unlatched position, a user can grab the front of the handle 104 and pull it out to the engaged position. As the handle is moved from the unlatched position to the engaged position, an engagement feature (see figure 2A) on the handle 104 pulls the retention clip 230 into a recess in the handle 104.

[0019] Figure 2 is a sectional top view of the example latching system of figure 1. In this view the retention clip 230 is located between the frame 102 and the handle 104. The back end 242 of the retention clip 230 is attached to the inside of the frame 102. In other examples the retention clip 230 and the leaf spring 108 may be combined into one part and may be attached to the frame in a different location. A locking tab 234 is formed on the front end of the retention clip 230. The locking tab 234 extends through an opening 232 in the frame 102.

[0020] When the latching system is installed into a mount inside a rack, the locking tab will extend through an opening in the mount and will lock the latching system into the mount. When the handle is in the latched position, the retention clip is free to bend or deflect towards the handle. This allows the latching system to be pushed into a mount in a rack.

[0021] The handle 104 is shown in the latched position. An engagement feature 238 on the handle 104 will contact a matching engagement feature 236 on the retention clip 230 when the handle is moved from the unlatched position into the engaged position (see figure 3). When the handle 104 is in the engaged position the retention clip 230 will be bent towards the handle 104 with the locking tab 234 positioned in a recess or open area 235 in the handle 104. Figure 3 is an isometric top view of an example handle and retention clip. The handle 304 has an engagement feature 338 extending out from the side of the handle 304 towards the retention clip 330. The retention clip 330 has a mating engagement feature 336 extending towards the handle 304.

[0022] In this view the handle 304 is shown in the unlatched position relative to the retention clip 330. In one example, when the handle 304 is in the unlatched position, the engagement feature 338 on the handle 304 has not engaged with the mating engagement feature 336 on the retention clip 330. Therefore the locking tab 334 will still be in an un-bent position. When the latching system is installed into a mount inside a rack, the locking tab will extend through an opening in the mount and will lock the latching system into the mount when the retention clip is in the un-bent condition. In other examples, when the handle 304 is in the unlatched position, the engagement feature 338 on the handle 304 may be partially engaged with the mating engagement feature 336 on the retention clip 330.

[0023] As the handle 304 is moved along the axis of motion in the direction shown by arrow 344, the engagement feature 338 on the handle 304 will mate with the engagement feature 336 on the retention clip 330 and will pull/bend the end of the retention clip towards the handle 304. The end of the retention clip will be pulled/bent in a direction generally perpendicular to the handle axis of motion. In this example, the engagement features on the handle 304 and the retention clip 330 are matching ramps or inclined planes. As the retention clip is bent towards the handle 304 it will be pulled against a support ramp 346 on the handle 304.

[0024] Figure 4A is an isometric back view (view AA) from figure 3. In this view the engagement feature 338 on the handle 304 is partially engaged with the mating engagement feature 336 on the retention clip 330. As the handle continues to move in the

direction shown by arrow 344, the engagement feature 338 on the handle 304 will more fully engage with the mating engagement feature 336 on the retention clip 330. As the engagement features become more fully engaged, the retention clip will be pulled/bent closer to the handle 304. Figure 4B is an isometric back view (view AA) from figure 3 with the engagement features fully engaged. When the engagement features are fully engaged the retention clip 330 will be against the support ramp 346 on the handle 304.

[0025] Figure 5 is a top view of the example handle and retention clip from figure 3 inside a frame. This view shows the handle 304 in the engaged position. Therefore the retention clip 230 is in the unlocked position. When the handle 304 is in the engaged position, the engagement feature 338 on the handle 304 is fully engaged with the mating engagement feature 336 on the retention clip 330 (as shown in figure 4B). The retention clip 330 is also held against the supporting ramp 346 on the side of the handle 304 and the locking tab 334 is pulled into the recess or opening 235 in the handle 104 (see figure 2 for location of recess or opening 235 in handle).

[0026] The top surface of the locking tab 334 is at position 556 with respect to the outside surface 560 of the frame 502. When the handle is in the unlocked position the top surface of the locking tab 334 would be at position 558 with respect to the outside surface 560 of the frame. The distance between position 556 and position 558 is distance d_2 . In one example distance d_2 is between 3.0 mm and 4.0 mm, for example 3.5 mm.

[0027] When the handle 304 is in the engaged position (as shown), the top surface of the locking tab 334 is distance d_4 below the outside surface 560 of the frame 502. In one example distance d_4 is between 0 and 0.5 mm. When distance d_4 is zero, the top surface of the locking tab 334 is flush with the outside surface 560 of the frame 502. When the handle 304 is disengaged (i.e. in the unlocked position), the top surface of the locking tab 334 extends beyond the outside surface 560 of the frame 502 by distance d_3 . In one example distance d_3 is between 3.0 and 4.0 mm.

[0028] The handle 304 has a stop 552 that mates with the tip 554 of the engagement feature 336 on the retention clip 330. Once the stop 552 in the handle reaches the tip 554 of the engagement feature 336 on the retention clip 330, further movement of the handle 304 in the direction of arrow 344 will move the full latching

system in that direction. Because the locking tab 334 is held in the handle recess 235 against the side of the handle 304 when the handle is in the engaged position, the latching system would be disengaged from any mount it was installed in. This allows the latching system, and any device it is attached to, to be pulled out of a mount by continuing to pull the handle in the direction of arrow 344.

[0029] In the examples above, the engagement features on the handle and the retention clip are mating ramps or inclined planes. In other examples, other types of engagement features may be used. Figure 6A is a partial view of an example engagement feature. The example engagement feature comprises an inclined plane 660 that would be attached to a retention clip (not shown) and a roller 662 attached to a mount 668 that would be coupled to the handle. As the handle is moved in the direction of arrow 644, the roller will contact the inclined plane 660 and pull the retention clips towards the handle.

[0030] Figure 6B is a partial view of another example engagement feature. This example engagement feature comprises a first gear rack 670 that would be attached to a retention clips (not shown) a gear 672 that would be mounted to the frame, and a second gear rack 674 that would be attached to a handle. As the handle is moved in the direction of arrow 644, the second gear rack would cause the gear to rotate. As the gear rotated, the first gear rack would move downward, perpendicular to the motion of the handle. As the first gear rack is moved downward (in this view), the retention clip would be pulled towards the handle. Other types of engagement features could also be used.

[0031] Figure 7 is an isometric front view of an example device. The device 770 has an example latching system 772 attached to only one side of the device 770. The latching system may be the example latching system shown in figure 1. The handle is shown in the latched position. The device 770 with the latching system 772 attached may meet the dimensional requirements of the small form factor (SFF) hard drive mounting system used in many server racks. In this example the dimensions for the device 770 with the latching system attached are 114.5 mm deep, 15 mm high and 76.5 mm wide. In other examples the dimensions may be bigger or smaller. The device can be any type of

device that is mounted into a rack of a server, for example a hard drive, memory card, solid state memory, processor blade, Input/Output (I/O) card, network card or the like.

CLAIMS

What is claimed is:

1. A latching system, comprising:

a frame;

a handle, the handle mounted in the frame and movable along an axis of motion running between a front end and a back end of the handle, the handle movable between a latched position, an unlatched position and an engaged position, in order, along the axis of motion;

a handle latch attached to the frame and rotatable between a first position and a second position, when in the first position the handle latch holds the handle in the latched position, when in the second position the handle latch is disengaged from the handle;

a spring attached to the frame, the spring compressed between the frame and the back end of the handle when the handle is in the latched position, the handle forced to move to the unlatched position by the spring when the handle is in the latched position and the handle latch is rotated from the first position into the second position;

a retention clip attached to the frame, the retention clip movable between a locked position and an unlocked position;

the handle having an engagement feature, the engagement feature moving the retention clip from the locked position into the unlocked position as the handle moves from the unlatched position into the engaged position.

2. The latching system of claim 1, where one end of the retention clip moves generally perpendicular to the axis of motion when the retention clip is moved from the locked position into the unlocked position.

3. The latching system of claim 1, where the engagement feature is an inclined plane that mates with a matching inclined plane on the retention clip.

4. The latching system of claim 1, wherein when the handle is in the latched position the front of the handle is flush with a front of the frame; and

when the handle is in the unlatched position, the front of the handle extends beyond the front of the frame by between $\frac{1}{4}$ of an inch and 1 inch.

5. The latching system of claim 1, where the spring is a leaf spring and the leaf spring and the retention clip are integrated as one part.
6. The latching system of claim 1, wherein the latching system attaches to a side of a device to be mounted in a rack, and only one latching system is used to hold the device in the rack.
7. The latching system of claim 1, further comprising:
 - a locking tab at one end of the retention clip, where the locking tab is moved into a recess in the handle when the retention clip is moved from the locked position into the unlocked position.
8. The latching system of claim 7, wherein a top surface of the locking tab is flush with, or below, an outside surface of the frame when the retention clip is in the unlocked position.
9. The latching system of claim 7, wherein a top surface of the locking tab extends beyond an outside surface of the frame when the retention clip is in the locked position.
10. The latching system of claim 1, wherein the latching system is attached to a device selected from the following list of devices: a hard drive, a memory card, a solid state memory, a processor blade, and an Input/Output (I/O) card.
11. A device, comprising:
 - a main frame having two sides;
 - a latching system, the latching system attached to only one of the two sides of the main frame;
 - the latching system comprising

a frame;

a handle, the handle mounted in the frame and movable along an axis of motion running between a front end and a back end of the handle, the handle movable between a latched position, an unlatched position and an engaged position, in order, along the axis of motion;

a handle latch attached to the frame and rotatable between a first position and a second position, when in the first position the handle latch holds the handle in the latched position, when in the second position the handle latch is disengaged from the handle;

a spring attached to the frame, the spring compressed between the frame and the back end of the handle when the handle is in the latched position, the handle forced to move to the unlatched position by the spring when the handle is in the latched position and the handle latch is rotated from the first position into the second position;

a retention clip attached to the frame, the retention clip movable between a locked position and an unlocked position;

the handle having an engagement feature, the engagement feature moving the retention clip from the locked position into the unlocked position as the handle moves from the unlatched position into the engaged position.

12. The device of claim 11, wherein the device fits in a small form factor (SFF) mount in a server.

13. The device of claim 11, where one end of the retention clip moves generally perpendicular to the axis of motion when the handle is moved from the latched position into the unlatched position.

14. The device of claim 11, wherein when the handle is in the latched position the front of the handle is flush with a front of the device; and

when the handle is in the unlatched position, the front of the handle extends beyond the front of the device by between $\frac{1}{4}$ of an inch and 1 inch.

15. A method of manufacturing a latching system, comprising:
providing a frame;

mounting a handle in the frame, the handle movable along an axis of motion running between a front end and a back end of the handle, the handle movable between a latched position, an unlatched position and an engaged position, in order, along the axis of motion;

mounting a handle latch to the frame, the handle latch rotatable between a first position and a second position, when in the first position the handle latch holds the handle in the latched position, when in the second position the handle latch is disengaged from the handle;

attaching a spring to the frame, the spring compressed between the frame and the back end of the handle when the handle is in the latched position, the handle forced to move to the unlatched position by the spring when the handle is in the latched position and the handle latch is rotated from the first position into the second position;

attaching a retention clip to the frame, the retention clip movable between a locked position and an unlocked position;

the handle having an engagement feature, the engagement feature moving the retention clip from the locked position into the unlocked position as the handle moves from the unlatched position into the engaged position.

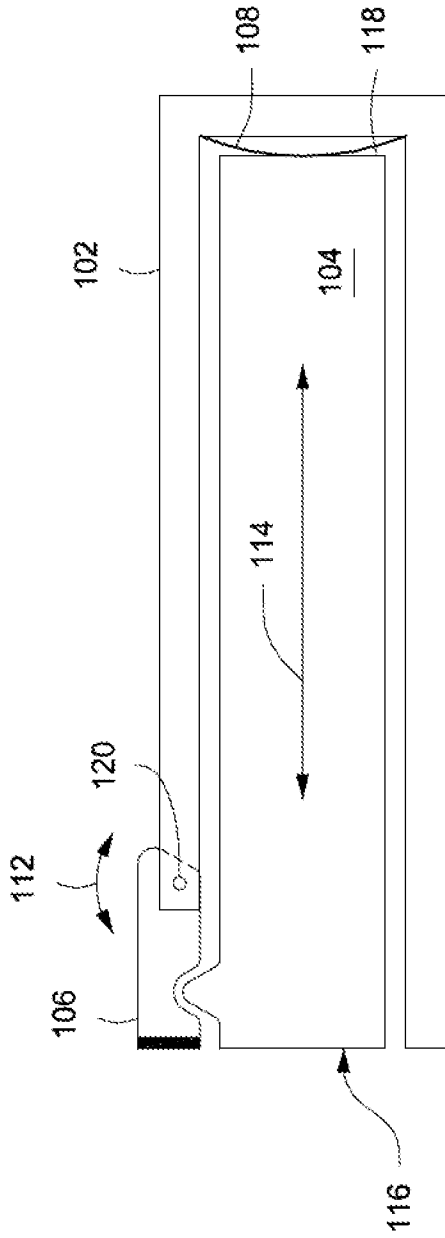

FIG. 1A

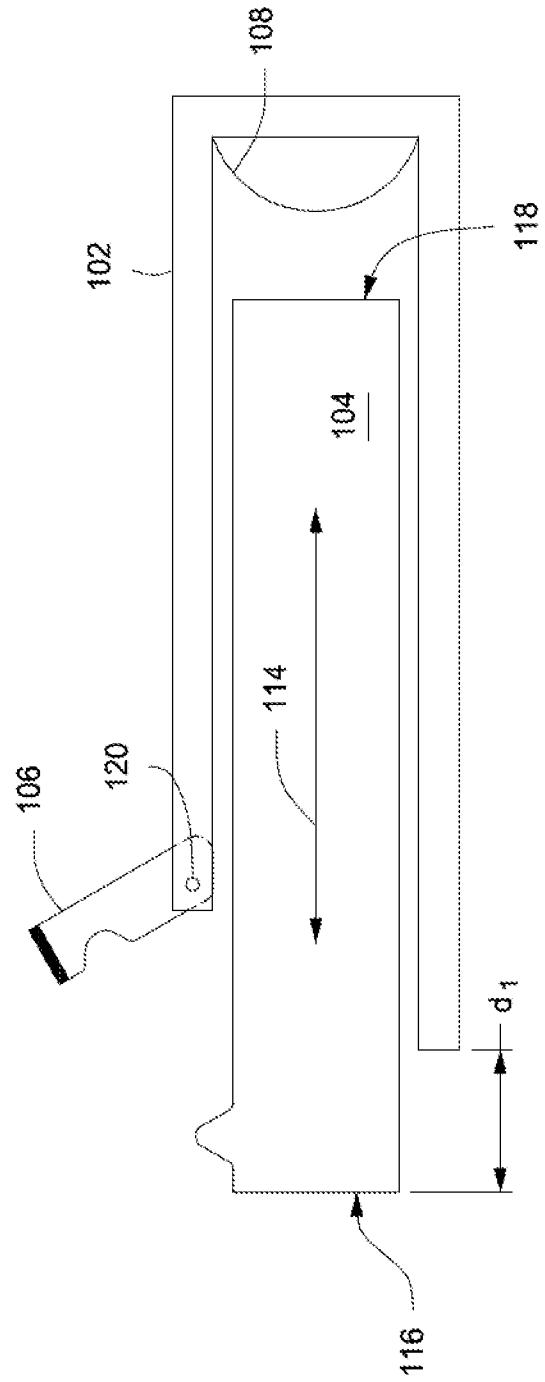

FIG. 1B

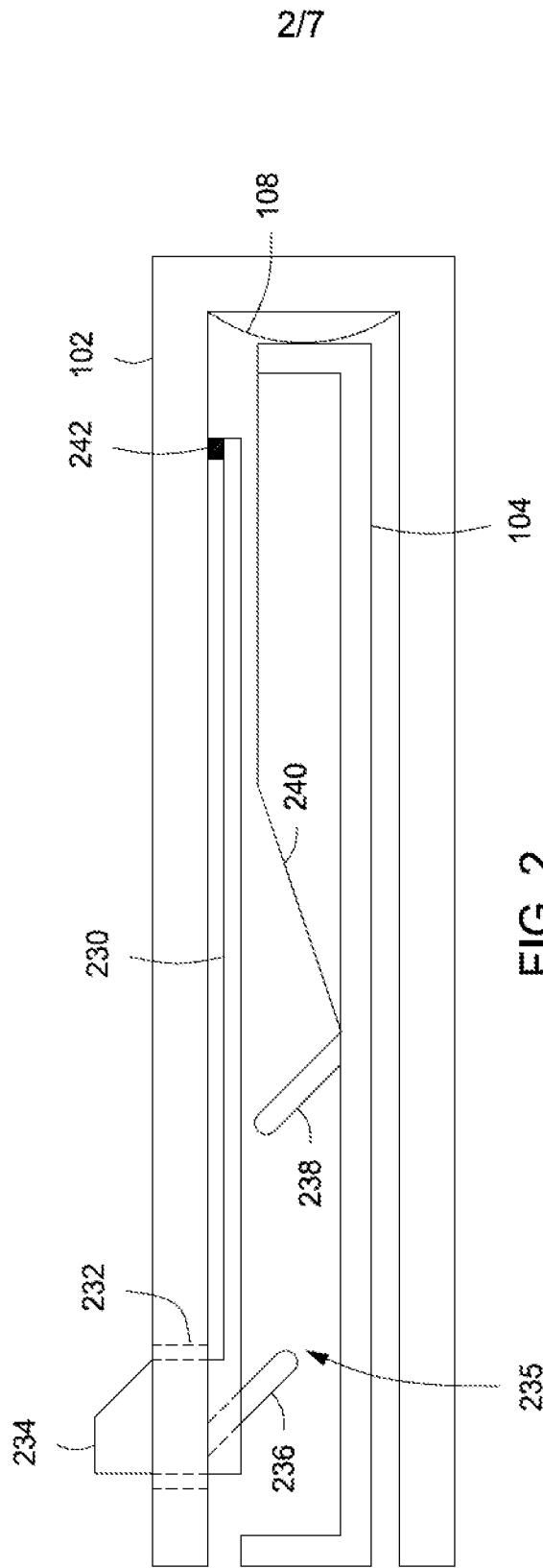

FIG. 2

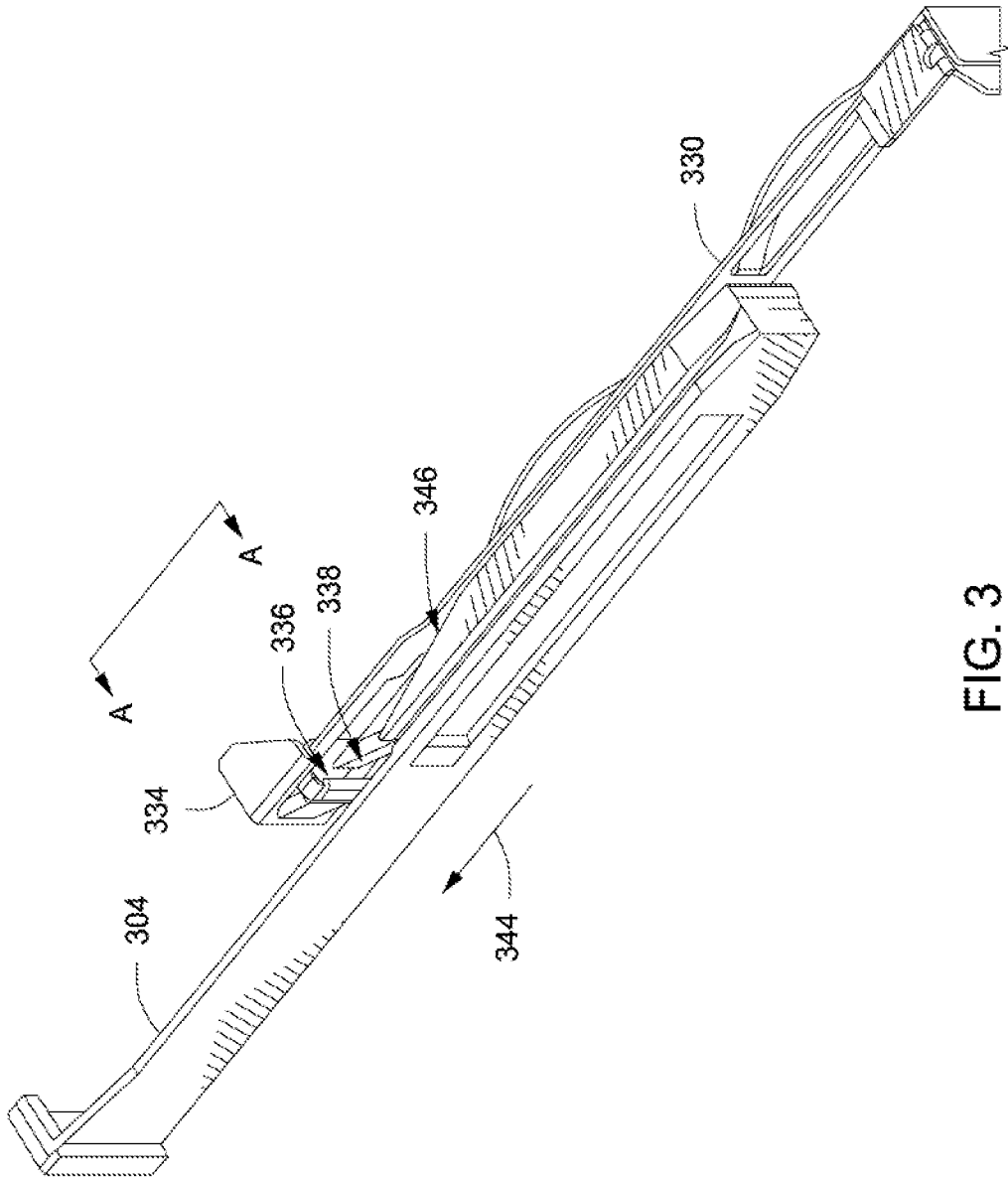

FIG. 3



4/7

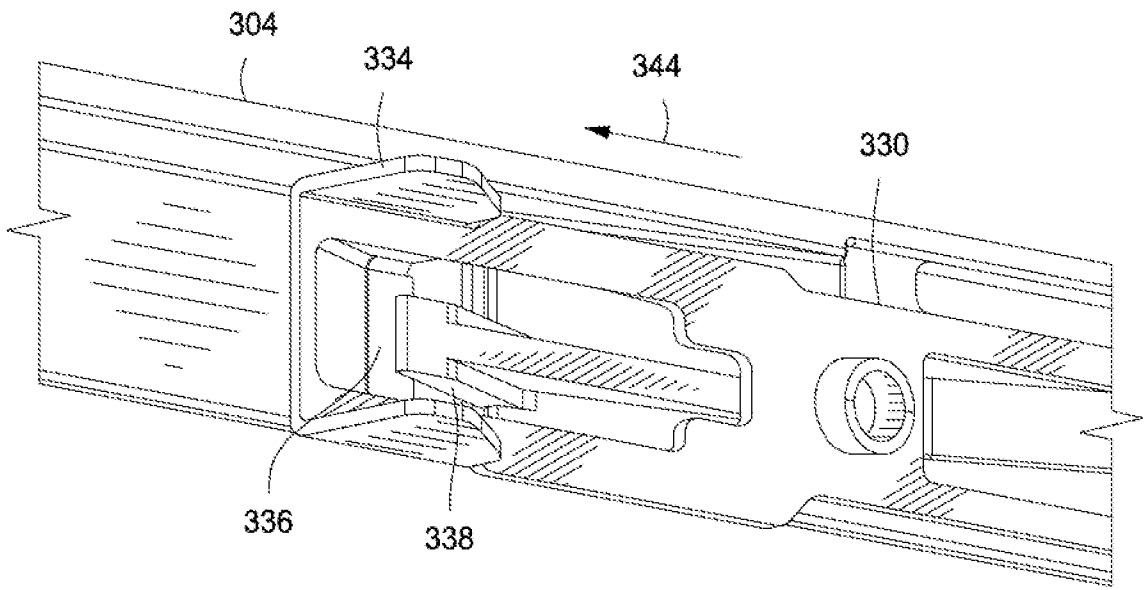

FIG. 4A

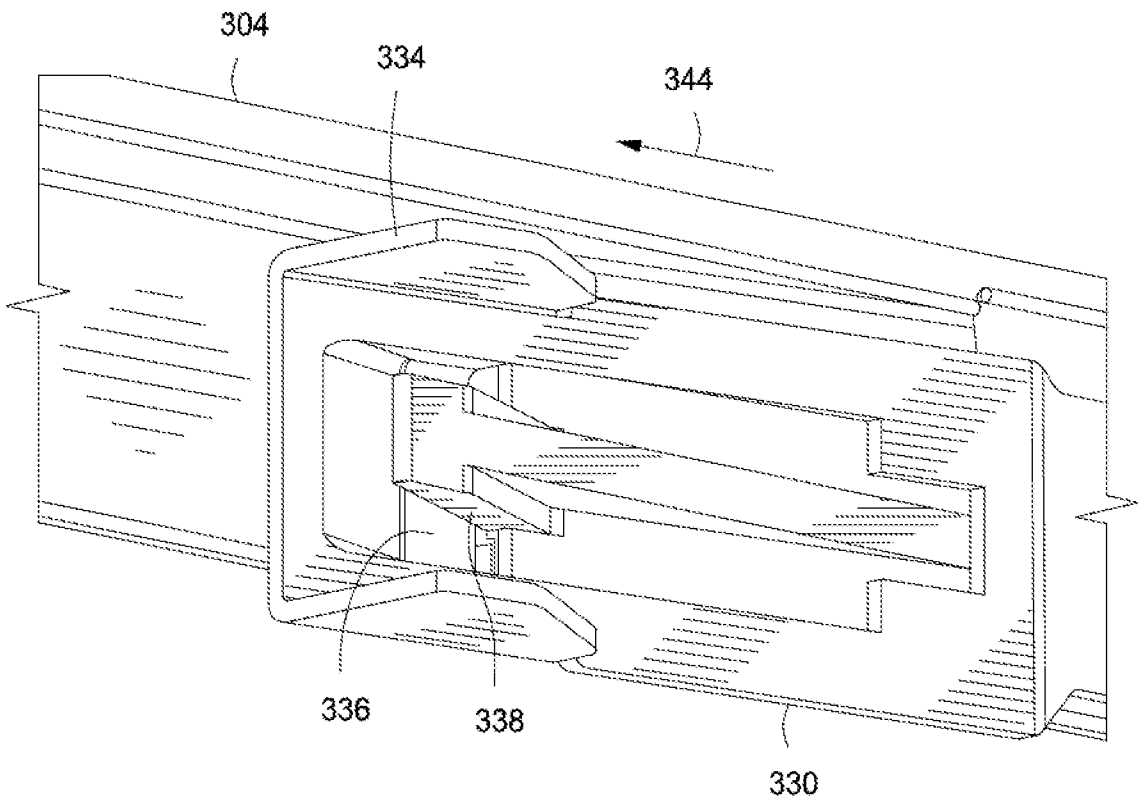

FIG. 4B



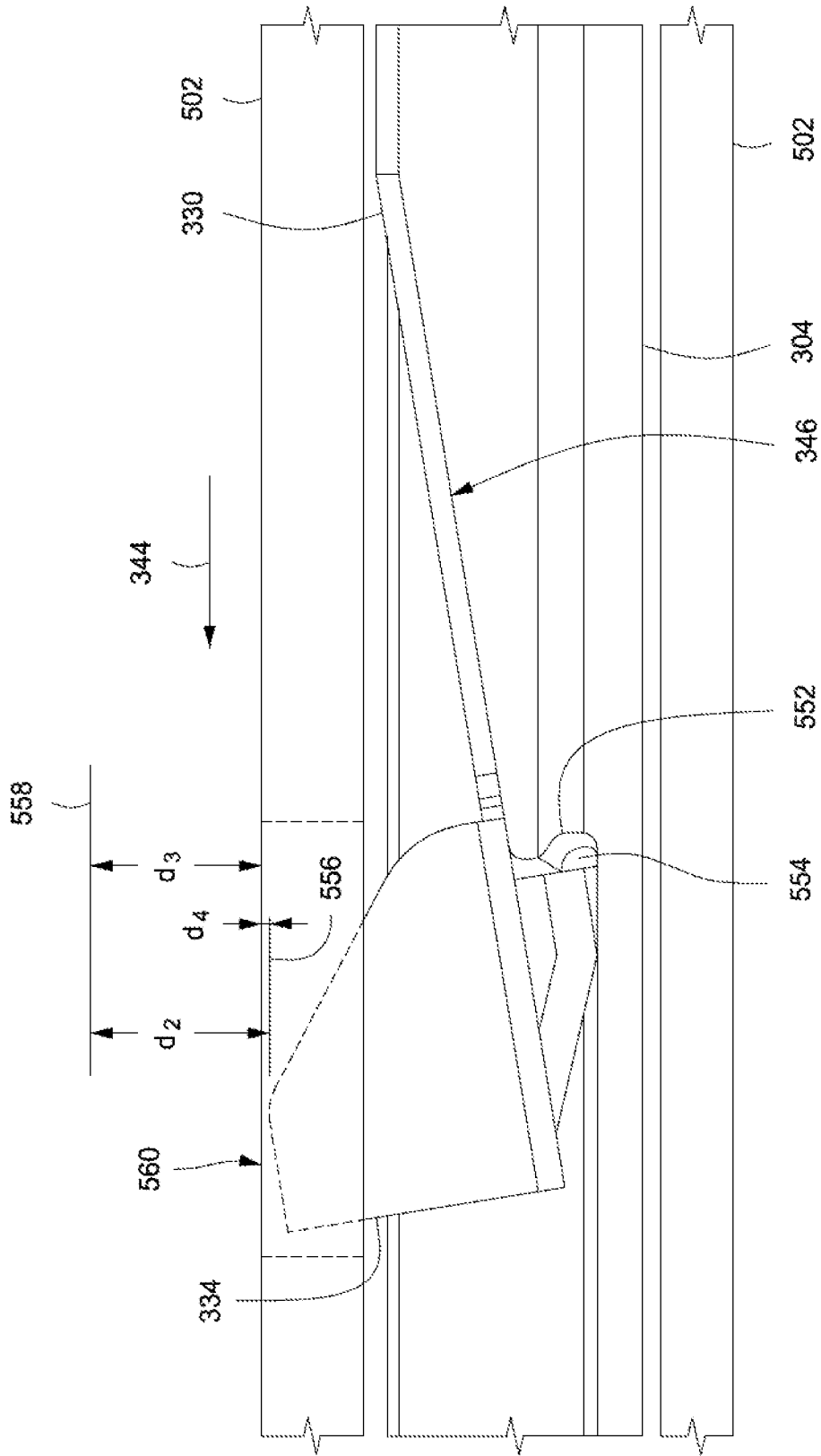

FIG. 5

6/7

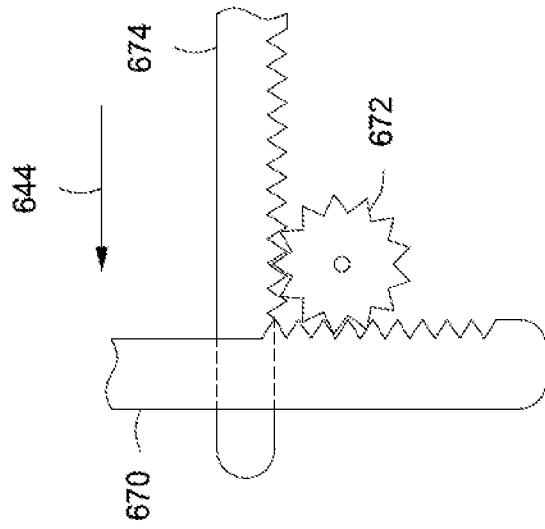

FIG. 6B

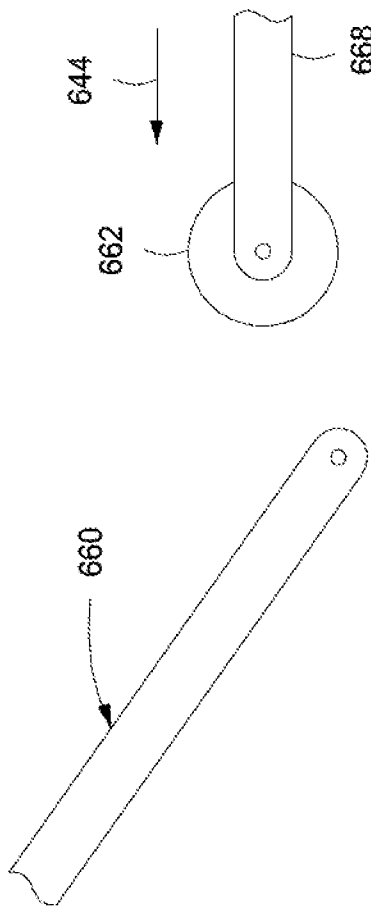

FIG. 6A

┌

717

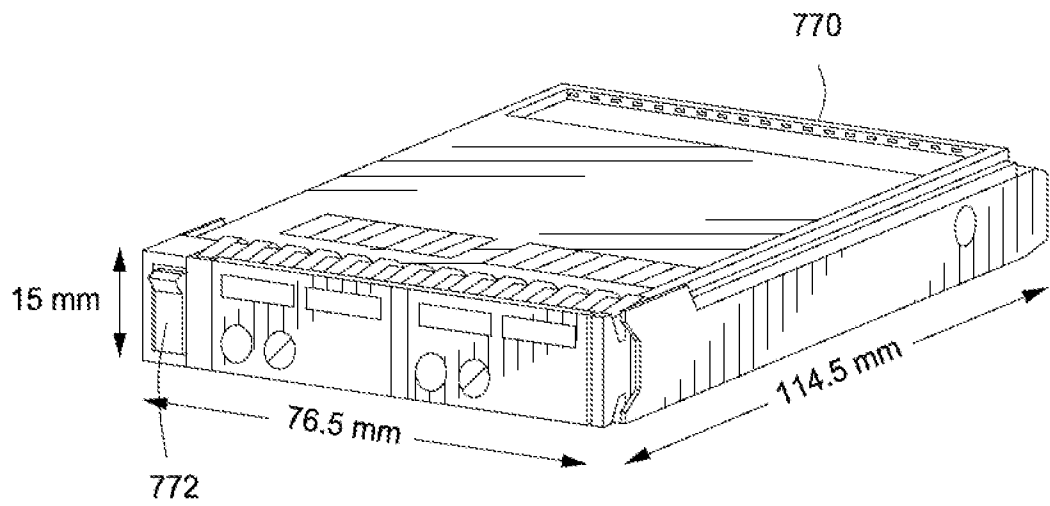

FIG. 7

└

A. CLASSIFICATION OF SUBJECT MATTER**H05K 7/18(2006.01)i**

According to International Patent Classification (IPC) or to both national classification and IPC

B. FIELDS SEARCHEDMinimum documentation searched (classification system followed by classification symbols)
H05K 7/18; F16H 21/44; H05K 7/00; H01R 13/62; H05K 7/12; G06F 1/16Documentation searched other than minimum documentation to the extent that such documents are included in the fields searched
Korean utility models and applications for utility models
Japanese utility models and applications for utility modelsElectronic data base consulted during the international search (name of data base and, where practicable, search terms used)
eKOMPASS(KIPO internal) & Keywords: handle latch, spring, retention clip, engagement feature, rack**C. DOCUMENTS CONSIDERED TO BE RELEVANT**

Category*	Citation of document, with indication, where appropriate, of the relevant passages	Relevant to claim No.
Y	US 7573726 B1 (GERALD J. COTE et al.) 11 August 2009 See abstract, column 3, line 48 - column 5, line 62, claims 3-4, and figures 1-5B.	1-15
Y	US 2002-0104396 A1 (GEORGE D. MEGASON et al.) 08 August 2002 See paragraphs [0021]-[0029], claim 1, and figures 1-6.	1-15
A	US 6229708 B1 (JOHN SAUNDERS CORBIN, JR. et al.) 08 May 2001 See column 2, line 12 - column 6, line 12, claim 1, and figures 1, 3-5.	1-15
A	US 6490153 B1 (MATTHEW P. CASEBOLT et al.) 03 December 2002 See column 3, line 66 - column 5, line 67, claim 1, and figures 1-3, 5A-5C.	1-15
A	US 7264490 B1 (NAUM REZNIKOV) 04 September 2007 See column 3, line 65 - column 8, line 39, claim 1, and figures 1-3, 9-12.	1-15

 Further documents are listed in the continuation of Box C. See patent family annex.

* Special categories of cited documents:

"A" document defining the general state of the art which is not considered to be of particular relevance

"E" earlier application or patent but published on or after the international filing date

"L" document which may throw doubts on priority claim(s) or which is cited to establish the publication date of another citation or other special reason (as specified)

"O" document referring to an oral disclosure, use, exhibition or other means

"P" document published prior to the international filing date but later than the priority date claimed

"T" later document published after the international filing date or priority date and not in conflict with the application but cited to understand the principle or theory underlying the invention

"X" document of particular relevance; the claimed invention cannot be considered novel or cannot be considered to involve an inventive step when the document is taken alone

"Y" document of particular relevance; the claimed invention cannot be considered to involve an inventive step when the document is combined with one or more other such documents, such combination being obvious to a person skilled in the art

"&" document member of the same patent family

Date of the actual completion of the international search

31 August 2015 (31.08.2015)

Date of mailing of the international search report

31 August 2015 (31.08.2015)

Name and mailing address of the ISA/KR

International Application Division
Korean Intellectual Property Office
189 Cheongsu-ro, Seo-gu, Daejeon Metropolitan City, 302-701,
Republic of Korea

Facsimile No. +82-42-472-7140

Authorized officer

KIM, Sung Gon

Telephone No. +82-42-481-8746

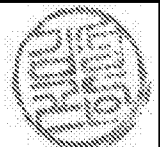

INTERNATIONAL SEARCH REPORT

Information on patent family members

International application No.

PCT/US2014/070553

Patent document cited in search report	Publication date	Patent family member(s)	Publication date
US 7573726 B1	11/08/2009	None	
US 2002-0104396 A1	08/08/2002	US 6354164 B1 US 6912124 B2	12/03/2002 28/06/2005
US 6229708 B1	08/05/2001	None	
US 6490153 B1	03/12/2002	AU 2000-64987 A1 TW 476023 A WO 01-11454 A2 WO 01-11454 A3	05/03/2001 11/02/2002 15/02/2001 14/02/2002
US 7264490 B1	04/09/2007	None	