

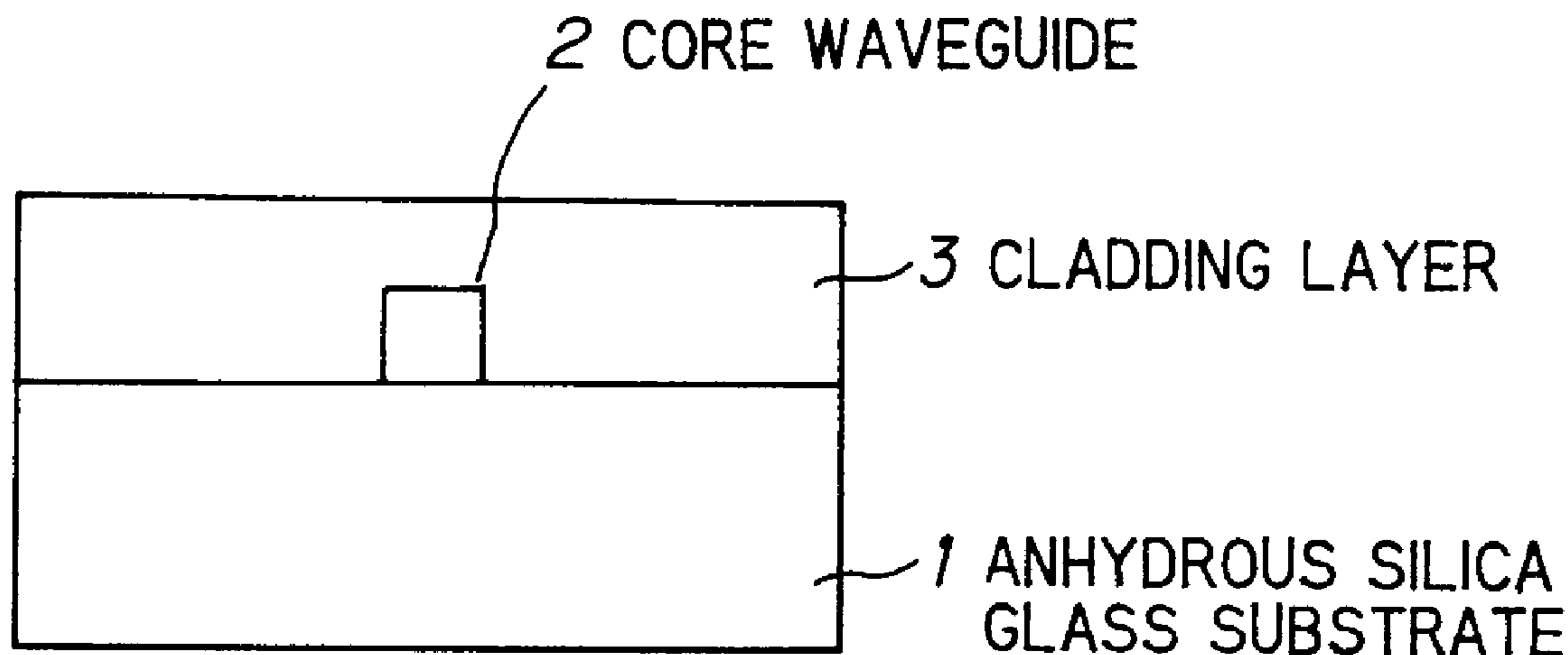

(22) Date de dépôt/Filing Date: 1996/08/29
 (41) Mise à la disp. pub./Open to Public Insp.: 1997/08/28
 (45) Date de délivrance/Issue Date: 2001/07/17
 (30) Priorité/Priority: 1996/02/27 (8-39366) JP

(51) Cl.Int.⁶/Int.Cl.⁶ G02B 6/122, G02B 6/12
 (72) Inventeurs/Inventors:
 Kamoshida, Toshikazu, JP;
 Mutoh, Yasuharu, JP;
 Okano, Hiroaki, JP
 (73) Propriétaire/Owner:
 Hitachi Cable, Ltd., JP
 (74) Agent: G. RONALD BELL & ASSOCIATES

(54) Titre : GUIDE DE LUMIERE ET MODULE ET SYSTEME OPTIQUES UTILISANT CE GUIDE
 (54) Title: OPTICAL WAVEGUIDE, OPTICAL MODULE AND OPTICAL SYSTEM USING THE SAME



(57) Abrégé/Abstract:

An optical waveguide comprises an anhydrous synthetic silica glass substrate which contains less than a predetermined concentration of hydroxyl group, a core waveguide having a rectangular cross-section being formed on the substrate, and a cladding layer having a lower refractive index than the core waveguide and which covers the core waveguide. The concentration of hydroxyl group contained in the synthetic silica glass substrate of the optical waveguide or the optical device is essentially less than 300 ppm, preferably less than 100 ppm, more preferably less than 50 ppm.

ABSTRACT

An optical waveguide comprises an anhydrous synthetic silica glass substrate which contains less than a predetermined concentration of hydroxyl group, a core waveguide having a rectangular cross-section being formed on the substrate, and a cladding layer having a lower refractive index than the core waveguide and which covers the core waveguide. The concentration of hydroxyl group contained in the synthetic silica glass substrate of the optical waveguide or the optical device is essentially less than 300 ppm, preferably less than 100 ppm, more preferably less than 50 ppm.

OPTICAL WAVEGUIDE, OPTICAL MODULE AND
OPTICAL SYSTEM USING THE SAME

5 This invention relates to an optical waveguide, an optical module and an optical
system using the same, and more particularly to an optical waveguide, an optical module
and an optical system using the same which are suitable for optical circuit devices, such
as optical star couplers, optical multiplexers/demultiplexers, optical switches, optical
modulators, wavelength-independent optical couplers, etc., and optical transmission
10 systems.

 Many optical systems, such as an optical subscriber's system, optical CATV,
optical submarine cable transmission systems and optical information processing systems,
have been developed actively. For the configuration of such optical systems, optical circuit
components, such as optical star couplers, optical multiplexers/demultiplexers, optical
15 switches, optical modulators, wavelength-independent optical couplers, and optical
transmission modules, in which optical circuit devices such as a semiconductor laser
and/or photodiodes, etc. are incorporated, are essential. Optical fiber-type devices and
optical waveguide-type devices are known to be used for such optical circuit devices. An
optical waveguide device is expected to achieve a small size, low-cost and be a productive
20 device because it also has the functions of an optical fiber-type device.

 An optical waveguide using a semiconductor substrate like silicon and an
optical waveguide using a silica glass substrate are already known. However, the optical
waveguide using the silica glass substrate is more advantageous because it can be
connected to an optical fiber by fusing techniques and less polarization-dependent loss is
25 obtained.

 A conventional optical waveguide comprises a silica group glass substrate, at
least one core waveguide formed thereon, and a cladding layer covering the core
waveguide, wherein a certain amount of at least one dopant is added into both the core
waveguide and the cladding layer so that the refractive index of the core waveguide is
30 higher than that of the cladding layer. For fabricating the conventional optical waveguide,
a silica glass substrate wafer is prepared, and a doped SiO₂ glass layer is deposited by
electron-beam deposition, which eventually forms the core waveguide. Next, a metal mask
is formed on the doped SiO₂ glass layer by sputtering, and a photoresist layer is formed
on the metal mask by a photolithography technique. After that, a core waveguide is

patterned on the substrate by reactive-ion etching. At this step, the substrate is treated at high temperature of greater than 1200 °C in order to stabilize the refractive index of the core waveguide. Next, a SiO₂ group porous glass layer as a cladding layer is formed by flame deposition by hydrolyzing source gases, then heated and consolidated at more than
5 1200 °C, and the cladding layer of transparent glass is obtained. Finally, the wafer is diced into each optical waveguide by a blade.

In the conventional optical waveguide and the conventional optical device using the same, however, there are disadvantages in that its connecting loss is likely to be extremely high, therefore the yield of fabrication thereof is low. Because deformation of
10 the substrate occurs through the high temperature treatment in the fabrication process, which results in a difference between the axes of the core waveguide and an optical fiber. Such deformations vary not only along the optical waveguide but also on the plane of the silica glass wafer where the optical waveguides are formed, and wafer by wafer.

Another disadvantage is that the expected optical characteristics of optical
15 devices, such as optical multiplexers/demultiplexers and wavelength-independent optical couplers are not obtained, because they depend on the lengths of the core waveguides. Furthermore, there is a disadvantage in that an absorption loss at the wavelength of 1.39 μ m exists, which seems to be caused by the existence of hydroxyl.

Accordingly, it is an object of the invention to provide an optical waveguide, an
20 optical module and an optical system using the same to which an optical fiber can be connected precisely, so that the alignment of axes between the core waveguide and the optical fiber is realized.

It is a further object of the invention to provide an optical waveguide, an optical
25 module and an optical system using the same by which expected optical characteristics are obtained without special treatment, and in which absorption loss at the wavelength of 1.39 μ m can be reduced.

It is a still further object of the invention to provide an optical waveguide, an
optical module and an optical system using the same which can be fabricated with high yield and low cost.

30 According to the first feature of the invention, an optical waveguide comprises a substrate and at least one core waveguide formed on the substrate for transmitting light therein, wherein the substrate is a pure SiO₂ synthetic silica glass substrate containing less than a predetermined concentration of hydroxyl group.

According to the second feature of the invention, an optical module comprises a substrate at least one core waveguide formed on the substrate for transmitting light therein, at least one optical device for emitting light into the at least one core waveguide or receiving light from the at least one core waveguide, the at least one optical device being
5 connected to one end of the at least one core waveguide, and at least one optical fiber connected to an opposite end of the one core waveguide, wherein the substrate is a pure SiO₂ synthetic silica glass substrate containing less than a predetermined concentration of hydroxyl group.

According to the third feature of the invention, an optical system comprises an
10 optical emitting module comprising a substrate, at least one core waveguide formed on the substrate for transmitting light therein, at least one optical device for emitting light into the at least one core waveguide, the at least one optical device being connected to one end of the at least one core waveguide, wherein the substrate is a pure SiO₂ synthetic silica glass substrate containing less than a predetermined concentration of hydroxyl group, an
15 optical receiving module comprising a substrate, at least one core waveguide formed on the substrate for transmitting light therein, at least one optical device for emitting light into the at least one core waveguide or receiving light from the at least one core waveguide, the at least one optical device being connected to one end of the at least one core waveguide, wherein the substrate is a pure SiO₂ synthetic silica glass substrate containing
20 less than a predetermined concentration of hydroxyl group, an optical transmitter in which the optical emitting module is incorporated, an optical receiver in which the optical receiving module is incorporated, and an optical fiber for connecting the optical transmitter to the optical receiver.

25 BRIEF DESCRIPTION OF THE DRAWINGS

The invention will be explained in more detail in conjunction with the appended drawings, wherein:

Figure 1 is a cross-sectional view showing a conventional optical waveguide,

Figure 2 is an explanatory view showing a method for manufacturing a
30 conventional optical waveguide,

Figure 3 is a cross-sectional view showing an optical waveguide in a first preferred embodiment according to the invention,

Figure 4 is a graph showing characteristics of deformation temperature to the concentration of hydroxyl group for various silica glasses,

Figures 5A and 5B are graphs showing characteristics of absorption loss to wavelength for a conventional optical waveguide using a hydroxyl-containing synthetic silica glass substrate, and an optical waveguide using anhydrous synthetic silica glass substrate according to the invention, respectively,

5 Figure 6 is a plan view showing a Mach-Zehnder interferometer according to the invention,

Figure 7 is a plan view showing a WDM filter according to the invention.

10 Before describing an optical waveguide and optical device using the same according to the first preferred embodiment, the aforementioned conventional connecting structures will be described with reference to Figures 1 and 2.

15 Figure 1 shows a conventional optical waveguide, which comprises a silica glass substrate 41, at least one core waveguide 42 (two core waveguides in Figure 1) formed on the silica glass substrate 41, and a cladding layer 43 covering the core waveguide 42, wherein a certain amount of at least one dopant are added into both the core waveguide 42 and the cladding layer 43 so that the refractive index of the core waveguide 42 is higher than that of the cladding layer 43.

20 Figure 2 shows a conventional method for fabricating the optical waveguide shown in Figure 1. First, a silica glass substrate wafer 51 is prepared, and a doped SiO₂ glass layer 54 is deposited by electron-beam deposition, which eventually forms the core waveguide (STEP A). Next, a metal mask 55 is formed on the doped SiO₂ glass layer 54 by sputtering (STEP B), and a photoresist layer 56 is formed on the metal mask 55 by a photolithography technique (STEP C). After that, a core waveguide 52 is patterned on the substrate 51 by reactive-ion etching (STEP D). At this step, the substrate 51 is treated at high temperatures of more than 1200°C in order to stabilize the refractive index of the core waveguide 52. Next, a SiO₂ group porous glass layer 53 as a cladding layer is formed by flame deposition by hydrolyzing source gases (STEP E), then heated and consolidated at more than 1200°C, and the cladding layer 53 of transparent glass is obtained (STEP F). Finally, the wafer 51 is diced into each optical waveguide 58 by a blade 59 (STEP G).

30 A conventional 2-input x 16-output waveguide-type optical star coupler (not shown) was fabricated by the method shown in Figure 2. Optical fiber arrays (not shown), one end of which is positioned in the V-shaped groove (not shown) formed on the surface of a block (not shown), is connected to the output ports of the optical star coupler. However, a number of output ports had extremely high connecting losses, and the yield of fabrication thereof was low. A cause thereof was investigated by the inventors, and it was

then found that a deformation of the substrate occurs by the high temperature treatment in the fabrication process, which results in a difference between the axes of the core waveguide and an optical fiber. For example, such deformation includes the contraction of the pitches between each core waveguide, and large warping of the substrates such that it was almost impossible to mount the device on a package. Because these deformations vary depending on not only the optical waveguide itself but also with the plane of the silica glass wafer where the optical waveguides are formed and with each wafer, it was difficult to solve these disadvantages by designing an optimum configuration of the waveguide which included such contraction and warping which would occur.

The deformations discussed above also prevented obtaining the expected optical characteristics of optical devices, in optical circuits such as optical multiplexers/demultiplexers and wavelength-independent optical couplers, because the optical characteristics of such circuits depend on the lengths of the core waveguides.

Furthermore, an absorption loss at the wavelength of $1.39 \mu\text{m}$ existed in the conventional optical waveguide and the conventional optical device using the same. This absorption loss seems to be caused by the existence of hydroxyl. The inventors considered that it was caused by waveguide layer forming process, and studied the various conditions. However, the absorption losses could not be eliminated.

Next, referring to Figure 3, a principle of an optical waveguide according to the invention will be described. The optical waveguide comprises an anhydrous silica glass substrate 1, at least one core waveguide 2 in which light travels and a cladding layer 3 covering the core waveguide 2. The inventors have found that the lower the concentration of the hydroxyl group is, the higher the heat-resistant temperature is in a pure SiO_2 synthetic silica glass substrate. If such pure SiO_2 synthetic silica glass substrate which contains less than a predetermined concentration of hydroxyl group is used, the contraction and warping of the waveguide is reduced. Therefore, optical fibers can be precisely connected to the core waveguides of the optical waveguide, and expected optical characteristics may be obtained. Furthermore, the inventors found that the optical absorption at $1.39 \mu\text{m}$ wavelength was caused by the existence of hydroxyl in the core waveguide which was diffused from the silica glass substrate. Therefore, if the silica glass substrate is substantially free from hydroxyl, the optical absorption can be reduced.

In the invention, the concentration of hydroxyl group contained in a synthetic silica glass substrate of an optical waveguide or an optical device is essentially less than 300 ppm, preferably less than 100 ppm, more preferably less than 50 ppm.

For fabricating synthetic silica glasses, it is known that silicon tetrachloride is decomposed in an oxyhydrogen flame or plasma flame to deposit silica glass. Also, for reducing the hydroxyl from synthetic silica glasses, dehydration by chlorine is known. However, in both processes about 10 ppm ~ 1000 ppm of chlorine remains in silica glasses. This residual chloride may make the heat-resistant characteristics of the glass, i.e. the softening temperature of the glass, lower. Therefore, it is also important for the invention that a synthetic silica glass substrate is substantially free of chloride.

Furthermore, the synthetic silica glass substrate should have a deformation temperature (which is defined below) of 1000°C, preferably greater than 1050°C. The deformation temperature is defined as a temperature where the coefficient of viscosity is $10^{14.5}$ P (poise), which is determined by setting and heating a wafer having a 6 inch diameter and 0.8 mm thickness in a furnace, putting weight of 500 g (gram) on the wafer, and measuring the extension of the wafer at each temperature. The lower the concentration of hydroxyl is, the higher the deformation temperature becomes, and less deformation of a substrate occurs at a given temperature.

In the invention, a pure SiO₂ synthetic glass substrate means a SiO₂ synthetic glass substrate which contains less than 10 ppm of metal impurities of heavy metals like Fe, Cu, alkaline metals like Na, Ca, K etc. and alkali earth metals. These metal impurities may make the deformation temperature or the softening temperature lower, and may affect the refractive index of the core waveguide by diffusion. Therefore, the concentration of the metal impurities must be less than 10 ppm, preferably 1 ppm.

An optical waveguide of a preferred embodiment according to the invention will now be described with reference to Figure 3. The optical waveguide comprises an anhydrous synthetic silica glass substrate 1, which contains less than a predetermined concentration of hydroxyl group, a core waveguide 2 having a rectangular cross-section being formed on the substrate 1, and a cladding layer 3 having a lower refractive index than the core waveguide 2 being covered by the cladding layer 3. For example, the core waveguide is 8 μm wide and 8 μm high, and made of TiO₂-SiO₂ group glass, etc. The material of the cladding layer may be B₂O₃-P₂O₅-SiO₂ group glass, for example, and the composition thereof is determined such that the refractive index difference coefficient between the core waveguide and the cladding layer is approximately 0.3%.

The conventional hydroxyl-containing synthetic silica glass wafers, deformations of which occur by high temperature treatment in their fabrication process, were prepared and their concentrations of hydroxyl were measured. It was found that each

wafer had a concentration of approximately 1000 ppm, the minimum values thereof in part of each wafer surface were more than 400 ppm.

The inventors considered that the concentration of hydroxyl in the wafer (substrate) was associated with the heat-resistant characteristics, and experimented on wafers having lower concentrations of hydroxyl. As a result, it has found that the lower the concentration of hydroxyl is, the lower the deformation of the wafer, i.e. the contraction and warping of the substrate that occurs by high temperature treatment in the fabrication process. Because the substrate resists softening at higher temperatures, an improved heat-resistance through decreased hydroxyl is achieved.

Actual experiments were carried out as follows. Ten (10) wafers of both hydroxyl-containing synthetic silica glass wafers and anhydrous synthetic silica glass wafers were prepared and seven (7) devices of 2-input 16-output waveguide-type optical star couplers were produced from each wafer. In this case, the total width of the 16-output port was 5 mm. The devices made from the hydroxyl-containing synthetic silica wafers had a mean contraction value of more than $4.5 \mu\text{m}$ of the pitch among the core waveguides from the designed value, and varied depending on each wafer and the location within each wafer. In contrast, the devices made from the anhydrous synthetic silica wafers had a mean contraction value of less than $2 \mu\text{m}$, even when the concentration of hydroxyl group was between 200 ppm and less than 300 ppm. The contraction values were suppressed to less than $1 \mu\text{m}$ with a concentration of hydroxyl of 100 ppm, and $0.5 \mu\text{m}$ with hydroxyl concentrations of 50 ppm. Regarding warping of the wafers, the devices made from the hydroxyl-containing synthetic silica glass wafers had not only a mean value of $1 \mu\text{m}$, but also ten percent of these devices had warping of more than $2 \mu\text{m}$. Devices having such large warping are considered to be inappropriate for being mounted on a package. In contrast, the devices made from the anhydrous synthetic silica glass wafers had a mean warp of less than $0.8 \mu\text{m}$, even when the concentration of hydroxyl group was between 200 ppm and less than 300 ppm. The warping was suppressed to less than $0.5 \mu\text{m}$ with a concentration of hydroxyl group of 100 ppm, and to $0.2 \mu\text{m}$ with a concentration of 50 ppm. As indicated above, in order to suppress the deformation of an optical waveguide or an optical device, the concentration of hydroxyl in the synthetic silica glass substrate of the optical waveguide or the optical device should essentially be less than 300 ppm, preferably less than 100 ppm, more preferably less than 50 ppm.

Next, a Mach-Zehnder interferometer shown in Figure 6, and a Wavelength division Multiplexer/demultiplexer (WDM) filter, shown in Figure 7, according to the invention will now be described.

Figure 6 shows the Mach-Zehnder interferometer 60, which comprises a first core waveguide 61 and a second core waveguide 62, which are partially adjacent to each other at two positions to form couplers 63, 64, wherein the lengths of the first core waveguide and the second core waveguide between two couplers are designed to be different. The Mach-Zehnder interferometer is used in a long distance optical transmission system and in an optical amplifier for a fiber sensing system, etc. In operation, for example, when it is used for an optical amplifier, a superposed input light 66, which includes an excitation light of $0.98 \mu\text{m}$ and a signal light of $1.55 \mu\text{m}$ output from an amplifying medium, is input into an input end of the first core waveguide 61, and the signal light of $1.55 \mu\text{m}$, and the excitation light of $0.98 \mu\text{m}$ are divided and output from output ends of the first core waveguide and the second core waveguide as output lights 67.

Figure 7 shows the WDM filter, which comprises an input waveguide 71, a plurality of output waveguides 72 (8 output waveguides in Figure 7) and arrayed waveguides 75 having different lengths from each other, both ends of which are connected to the output end of the input waveguide 71 and the input end of the output waveguide 72 by slab waveguide 73, 74, respectively. The WDM filter 70 may be used as a part of a light source section of an optical transmitter or a detecting section of a receiver in a wavelength-division multiplexing optical transmission system. In operation, input signal lights of $\lambda 1 \sim \lambda 8$, which are input from the input waveguide 71, are divided into respective signal lights and output from each output waveguide 72. Alternatively, signal lights of $\lambda 1 \sim \lambda 8$, which are input from each output waveguide 72, respectively, are multiplexed and output from the input waveguide 71.

Experiments were carried out with the Mach-Zehnder interferometers shown in FIG. 6 and the WDM filters shown in Figure 7, which were made from both hydroxyl-containing synthetic silica glass wafers (substrates) and anhydrous synthetic silica wafers (substrates). Devices made from hydroxyl-containing synthetic silica glass wafers (substrates) contracted in circuit size, and less than 30% of samples met expected optical performance characteristics. In contrast, devices made from anhydrous synthetic silica glass wafers (substrates) did not contract so much, and 85% of samples having a hydroxyl concentration of less than 300 ppm met the expected optical characteristics. More than 95% of samples having less than 100 ppm hydroxyl group, and almost 100% having less

than 50 ppm did. Therefore, in order to improve the optical characteristics of an optical device, as mentioned before, the concentration of hydroxyl group contained in a synthetic silica glass substrate of an optical device should be essentially less than 300 ppm, preferably less than 100 ppm, more preferably less than 50 ppm.

5 For fabricating a synthetic silica glass substrate, if silicon tetrachloride is used as a source gas, or if dehydration is processed in a chlorine-containing gas atmosphere, a certain amount of chlorine remains in the substrate or is absorbed into the substrate, and such residual chlorine may cause the decrease in softening temperature, i.e. deformation temperature of the substrate. In the embodiment according to the invention, source gasses
10 that do not contain chlorine, like methoxysilane, etc., are used for the deposition of synthetic silica glass, and the dehydration process is carried out in a vacuum or inert gas atmosphere excluding chlorine, so that the substrate does not substantially contain chlorine.

Moreover, as described above, a pure SiO₂ synthetic glass substrate means
15 a SiO₂ synthetic glass substrate which contains less than 10 ppm of metal impurities of heavy metals such as Fe, Cu, alkaline metals like Na, Ca, K etc. and alkali earth metals. These metal impurities may cause the deformation temperature or the softening temperature to decrease, and may affect the refractive index of the core waveguide by diffusion. Therefore, in order to avoid such problems, high-purity source gas, having metal
20 impurities of less than 10 ppm, preferably 1 ppm, are used for the invention.

Figure 4 shows characteristics of deformation temperature to hydroxyl group concentration. As described above, the deformation temperature is defined as a temperature where the coefficient of viscosity is 10^{14.5} P (poise) which is determined by heating a wafer having a 6 inch diameter and 0.8 mm thickness in a furnace, and putting
25 weight of 500 g (gram) on the wafer, and measuring the extension of the wafer at each temperature. The graph indicates that the conventional substrate of hydroxyl-containing synthetic silica, which contains a hydroxyl concentration of more than 400 ppm, has a deformation temperature of less than 1000°C, while, the substrate of anhydrous synthetic silica, which contains a hydroxyl concentration of less than 100 ppm, has a deformation
30 temperature of more than 1050°C. This result shows that the concentration of hydroxyl group affects the deformation temperature, i.e. heat-resisting characteristics. Therefore, in order to reduce deformation of the substrate due to high temperature treatment during the fabrication process, the deformation temperature should be more than 1000°C, preferably 1050°C, more preferably 1100°C (with respect to a concentration of hydroxyl

of less than 10 ppm). A substrate of natural silica (flame-fused) glass substrate has higher deformation temperatures than that of anhydrous synthetic silica glass substrate. However, it contains metal impurities of more than several ten ppm, which may affect the optical characteristics of the optical device negatively. For example, such impurities diffuse
5 into a core waveguide formed on the substrate and vary the refractive index thereof. Therefore, such a substrate is rather inappropriate for a silica glass substrate of the invention.

Next, in order to investigate the influence of hydroxyl on an optical absorption at $1.39 \mu\text{m}$ wavelength in a core waveguide, some experiments were carried out by the
10 inventors. Substrates of both hydroxyl-containing synthetic silica glass and anhydrous synthetic silica glass were prepared, and optical waveguides having $8 \mu\text{m} \times 8 \mu\text{m}$ rectangular, 6 cm long straight core waveguides were fabricated and the characteristics of loss to wavelength were measured. In this case, the hydroxyl group-containing synthetic silica glass substrate contained hydroxyl group concentrations of 420 ppm, while the
15 anhydrous synthetic silica glass substrate was 50 ppm. The results are shown in Figures 5A and 5B. Although in the hydroxyl group-containing synthetic silica glass substrate, as shown in Figure 5A, a peak absorption loss of more than 1 dB is observed at $1.39 \mu\text{m}$ wavelength, there is no peak in the anhydrous synthetic silica glass substrate, as shown in Figure 5B. Therefore, in order to reduce the absorption loss at $1.39 \mu\text{m}$ in the core
20 waveguide, it is necessary to decrease the concentration of hydroxyl in the substrate as well as to take the conditions of fabrication process of the core waveguide into consideration.

In the invention, each value of the concentration of hydroxyl group was measured by an infrared spectroscopic analyzer (made by Nippon Bunko Sha).

25 In the invention, an optical module, which comprises an optical waveguide made from anhydrous synthetic silica glass substrate as described above, an optical element such as a light emitting element, a light detector connected to one end of a core waveguide, and an optical fiber connected to another end thereof, may be constructed. In this case, no defect in the connection of the core waveguide to such elements due to
30 deformation of the optical waveguide occurs, so that improved productivity and low cost of the optical module are realized. Furthermore, optical systems such as optical transmitters and optical receivers with high reliability may be realized by using such an optical module.

Moreover, as explained above, an optical system, comprising an optical fiber, an optical circuit device such as an optical star coupler, an optical multiplexer/demultiplexer, an optical switch, an optical modulator, a wavelength-independent optical coupler, etc., and connected to the optical circuit device, the optical fiber being connected to both an input port and an output port of the optical circuit device, may be constructed. Because the optical circuit device has such improved optical characteristics, and because optical fibers may be connected to the optical circuit device so precisely, an optical system with high reliability may be realized.

In summary, the invention provides the advantages set out below.

(1) An optical waveguide having little deformation of a substrate through its fabrication process. Therefore, the optical waveguide can be connected to an optical fiber without differences of axes, and expected optical performance characteristics can be realized.

(2) Much less hydroxyl group diffuses from the substrate into a core waveguide, so that optical absorption at $1.39 \mu\text{m}$ wavelength can be reduced.

(3) Improved productivity and low cost of an optical module are realized. Therefore, optical systems such as optical transmitters and optical receivers with high reliability may be realized by using such an optical module.

(4) An optical circuit device having improved optical characteristics, and to which optical fibers may be connected to the optical circuit device precisely, such that an optical system with high reliability may be realized.

Although the invention has been described with respect to specific embodiment for complete and clear disclosure, the appended claims are not to be thus limited but are to be construed as embodying all modification and alternative constructions that maybe occur to one skilled in the art which fairly fall within the basic teaching here is set forth.

THE EMBODIMENTS OF THE INVENTION IN WHICH AN EXCLUSIVE PROPERTY OR PRIVILEGE IS CLAIMED ARE DEFINED AS FOLLOWS:

1. An optical waveguide comprising:

a substrate; and

at least one core waveguide formed on said substrate for transmitting light therein; wherein said substrate is a pure SiO₂ synthetic silica glass substrate containing less than a predetermined concentration of hydroxyl group.

2. An optical waveguide according to claim 1, wherein:

the concentration of said hydroxyl group is less than 300 ppm.

3. An optical waveguide according to claim 1, wherein:

said pure SiO₂ synthetic silica glass substrate does not substantially contain any chlorine.

4. An optical waveguide according to claim 1, wherein:

a deformation temperature at which the viscosity of said substrate is 10^{14.5} poise is more than 1000°C.

5. An optical waveguide according to claim 1, wherein:

the concentration of said hydroxyl group is less than 100 ppm.

6. An optical waveguide according to claim 5, wherein:

said pure SiO₂ synthetic silica glass substrate does not substantially contain any chlorine.

7. An optical waveguide according to claim 5, wherein:

a deformation temperature at which the viscosity of said substrate is said pure $10^{14.5}$ poise is more than 1000°C .
8. An optical waveguide according to claim 1, wherein:

the concentration of said hydroxyl group is less than 50 ppm.
9. An optical waveguide according to claim 8, wherein:

said pure SiO_2 synthetic silica glass substrate does not substantially contain any chlorine.
10. An optical waveguide according to claim 8, wherein:

a deformation temperature at which the viscosity of said substrate is $10^{14.5}$ poise is more than 1000°C .
11. An optical waveguide according to claim 1, wherein:

said optical waveguide has a function as an optical device including an optical star coupler, an optical multiplexers/demultiplexer, an optical switch, an optical modulator, a wavelength-independent optical coupler, and an optical transmission module.
12. An optical module comprising:

a substrate;

at least one core waveguide formed on said substrate for transmitting light therein; at least one optical device for emitting light into said at least one core waveguide or receiving light from said at least one core waveguide, said at least one optical device being connected to one end of said at least one core waveguide; and at least one optical fiber connected to an opposite end of said one core waveguide; wherein said substrate is a pure SiO_2 synthetic silica glass substrate containing less than a predetermined concentration of hydroxyl group.

13. An optical system comprising:

an optical emitting module comprising: a substrate; at least one core waveguide formed on said substrate for transmitting light therein; at least one optical device for emitting light into said at least one core waveguide, said at least one optical device being connected to one end of said at least one core waveguide; wherein said substrate is a pure SiO₂ synthetic silica glass substrate containing less than a predetermined concentration of hydroxyl group; an optical receiving module comprising: a substrate; at least one core waveguide formed on said substrate for transmitting light therein; at least one optical device for emitting light into said at least one core waveguide or receiving light from said at least one core waveguide, said at least one optical device being connected to one end of said at least one core waveguide; wherein said substrate is a pure SiO₂ synthetic silica glass substrate containing less than a predetermined concentration of hydroxyl group; an optical transmitter in which said optical emitting module is incorporated;

an optical receiver in which said optical receiving module is incorporated; and an optical fiber for connecting said optical transmitter to said optical receiver.

14. An optical system according to claim 13, wherein:

each said pure SiO₂ synthetic silica glass substrate does not substantially contain any chlorine.

15. An optical system according to claim 13, wherein:

each deformation temperature at which each viscosity of said substrates is 10^{14.5} poise is more than 1000°C.

16. The optical waveguide according to any one of claims 1 to 11, wherein said substrate comprises a flat planar surface, and said at least one core waveguide is formed on a portion of said flat planar surface.

17. An optical module according to claim 12, wherein said substrate comprises a flat planar surface, and said at least one core waveguide is formed on a portion of said flat planar surface.

18. An optical system according to any one of claims 13 to 15, wherein said substrate comprises a flat planar surface, and said at least one core waveguide is formed on a portion of said flat planar surface.

FIG. 1
PRIOR ART

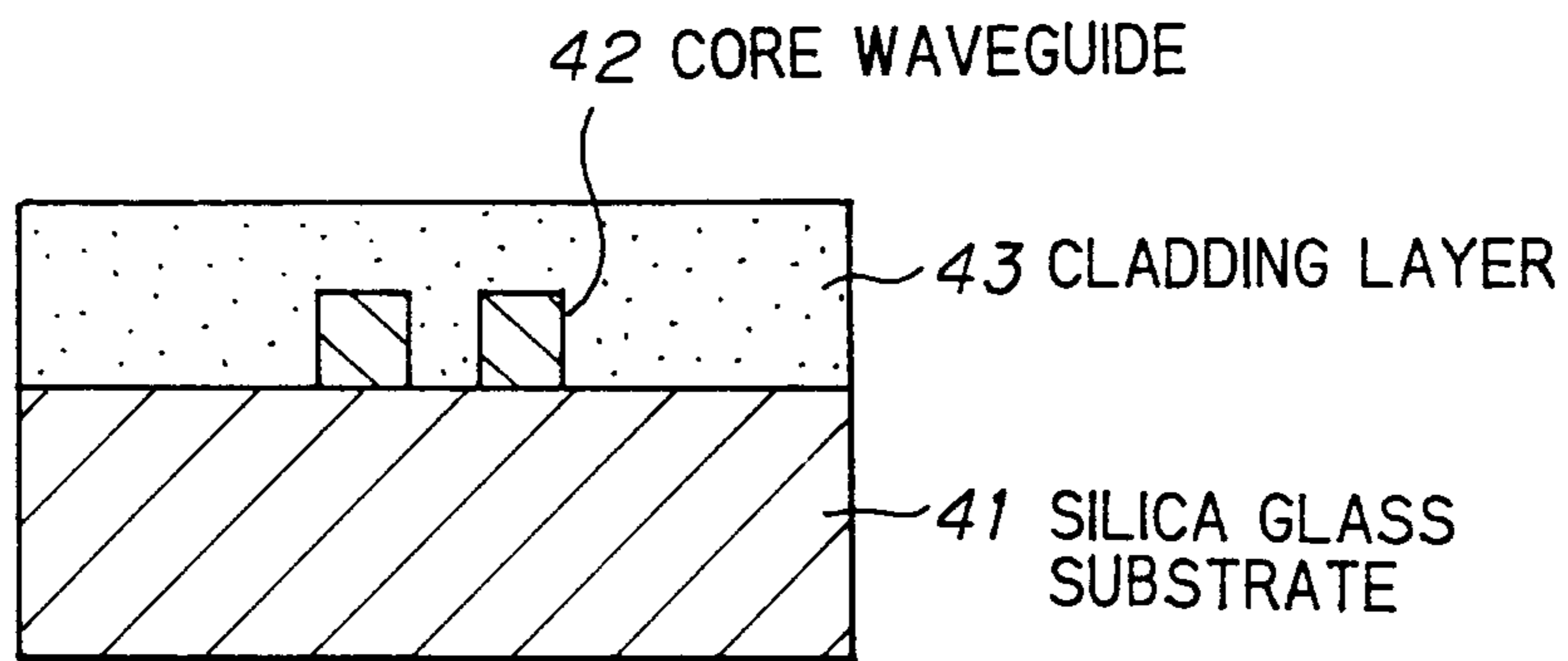

FIG. 2 PRIOR ART

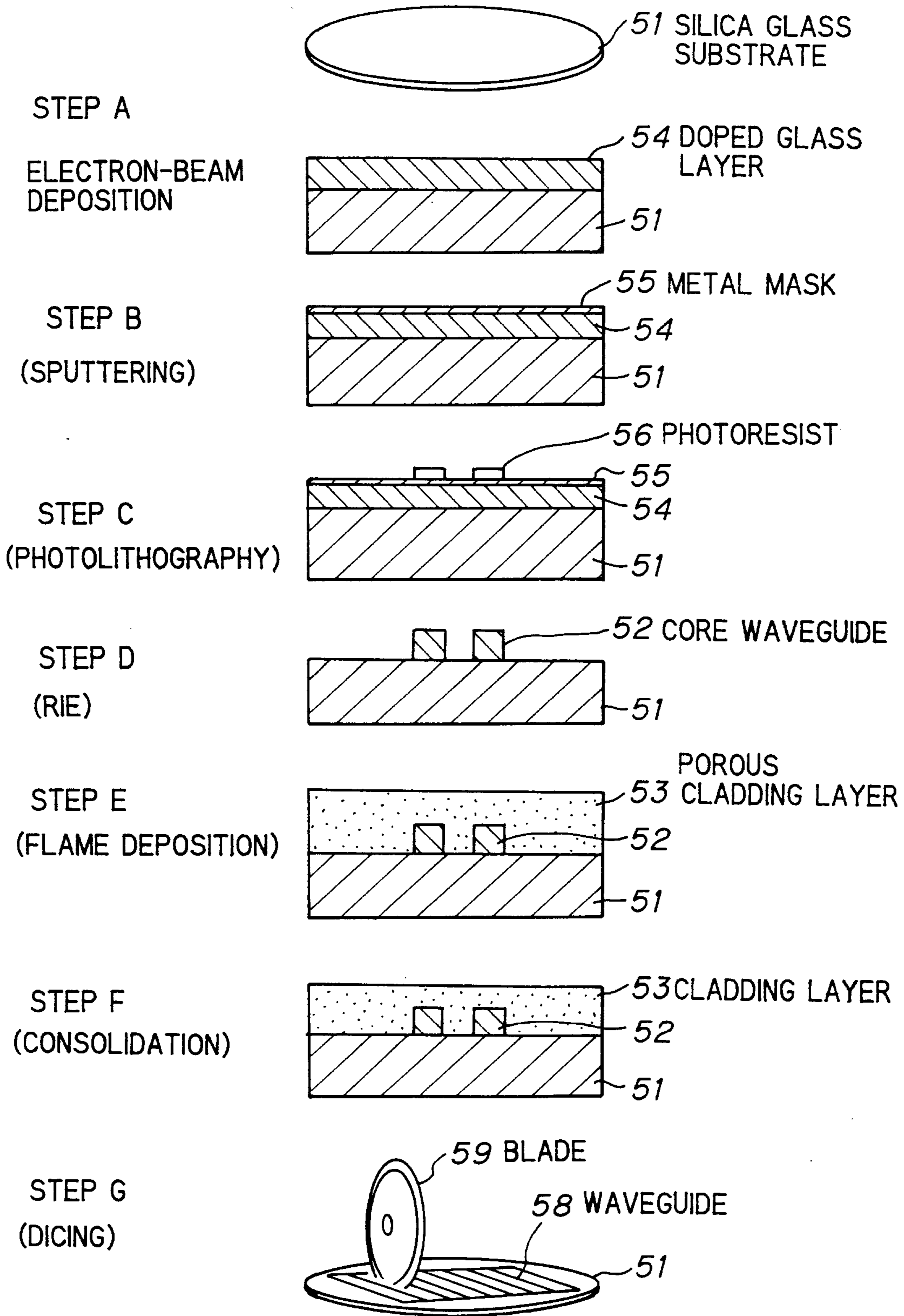

FIG. 3

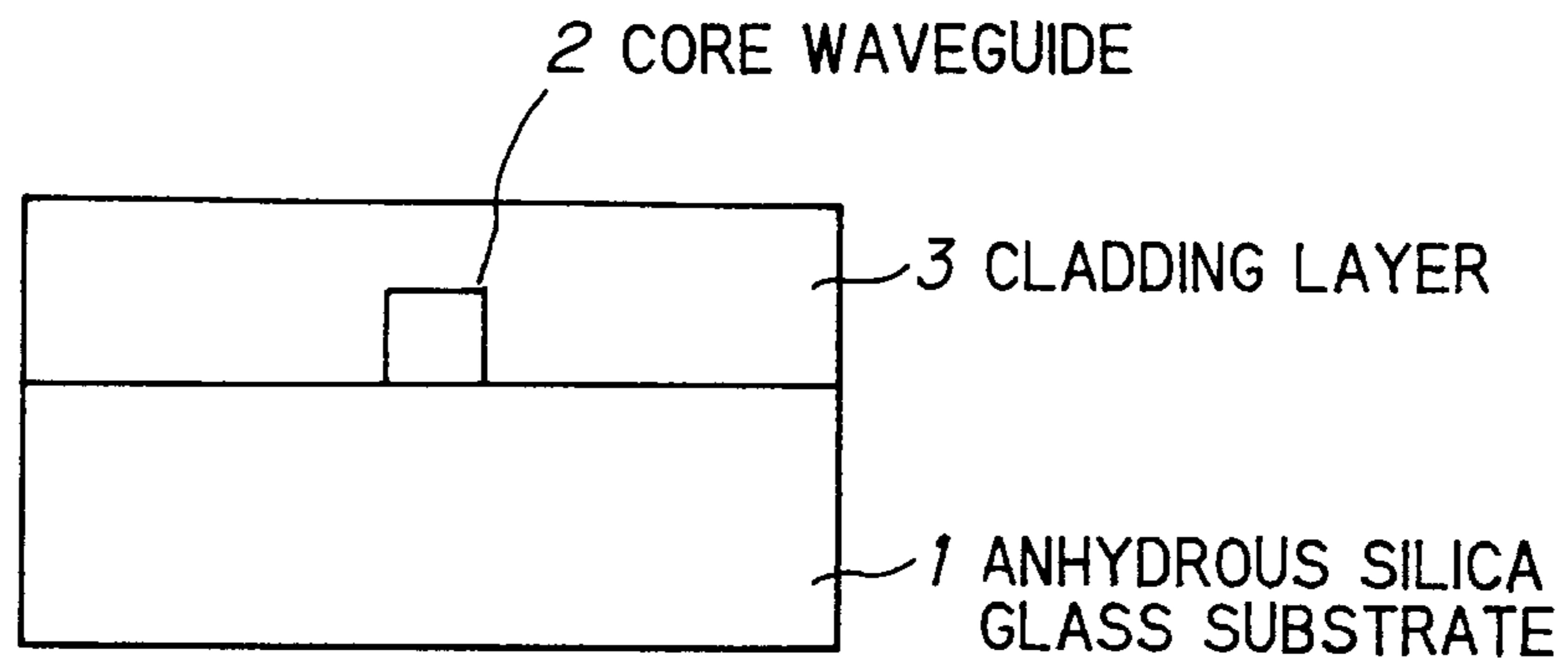

FIG. 4

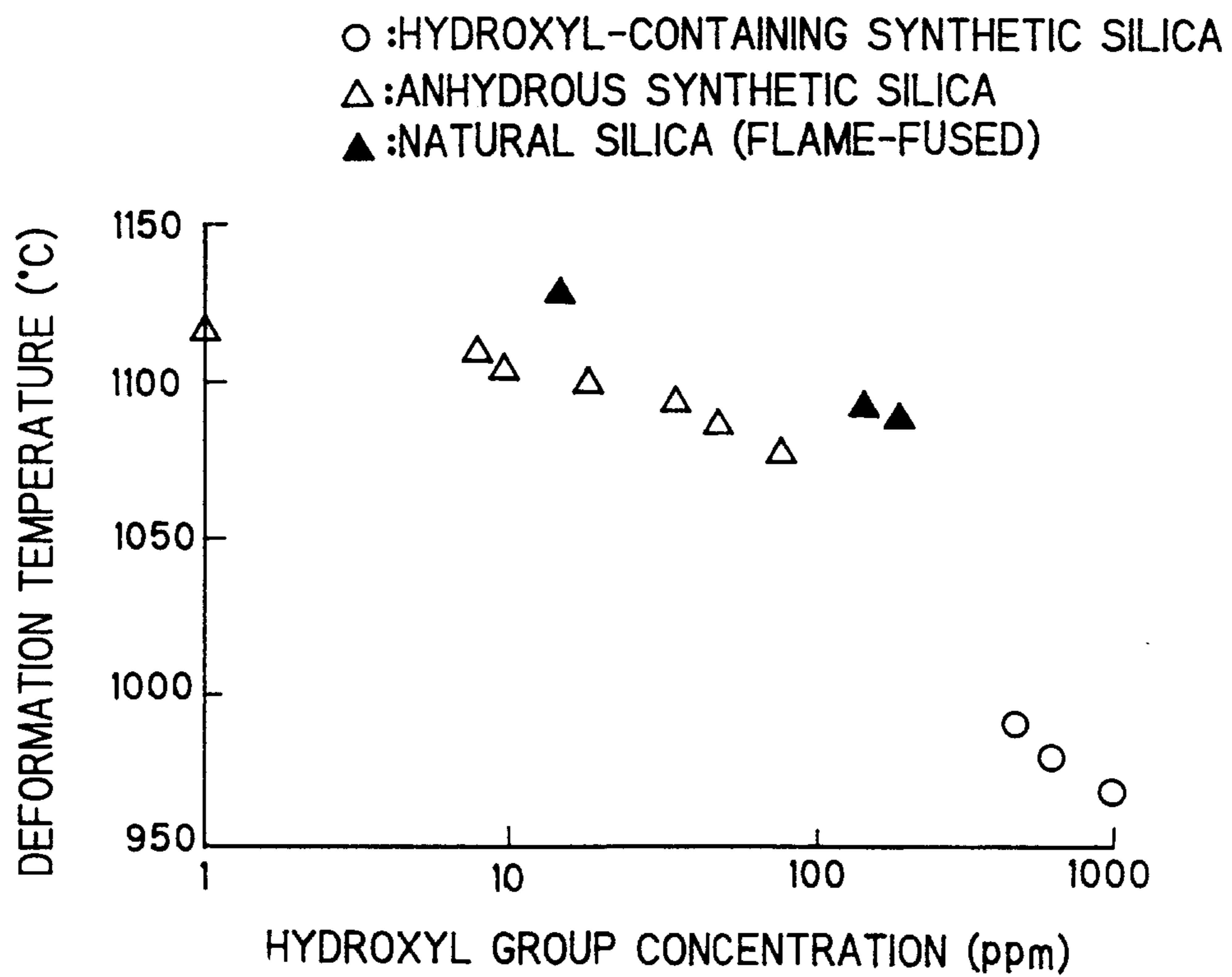
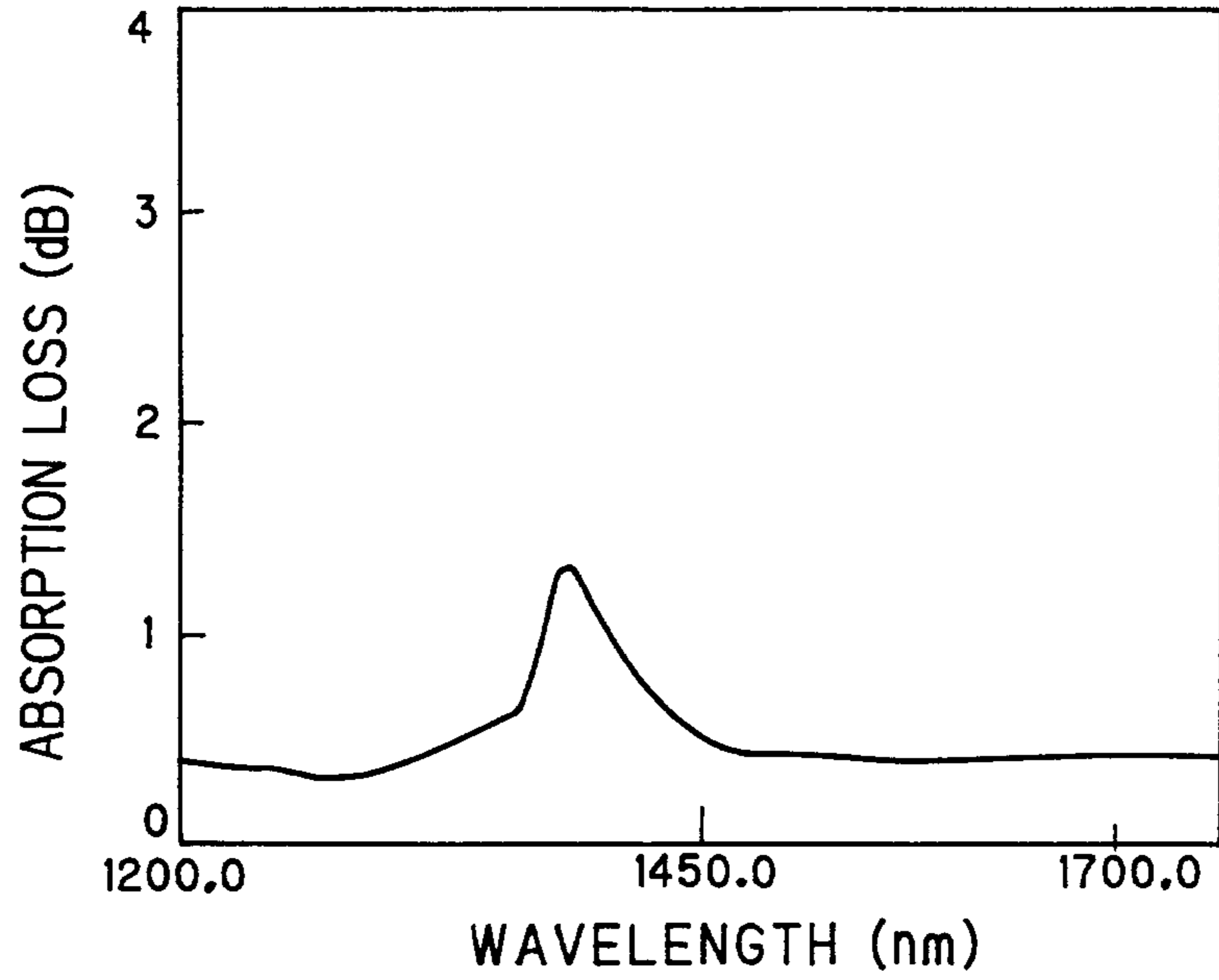
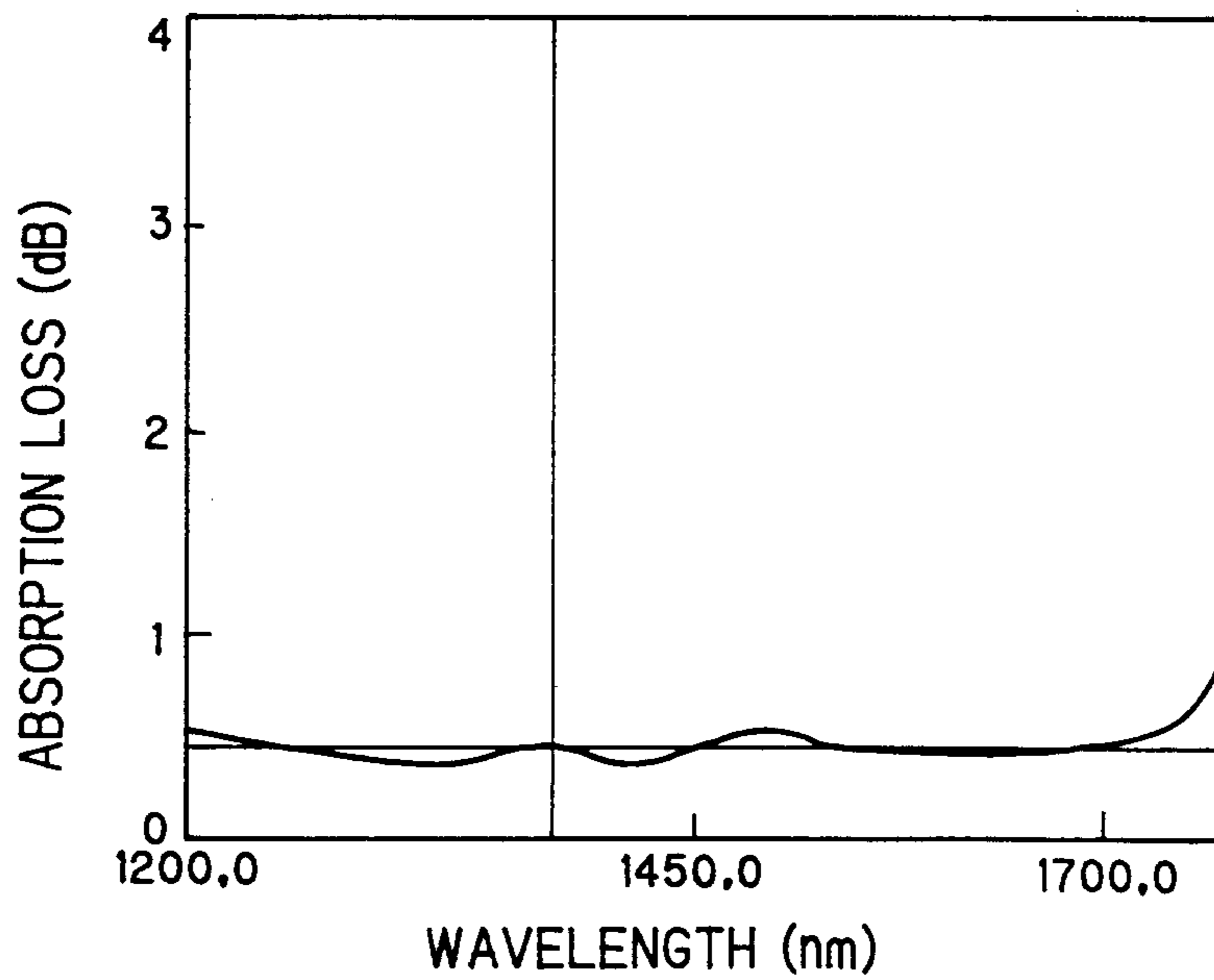

FIG.5A



SPN	50nm/	LS. 5dB/	RES 10nm	AVR	1	2
WMKR						
LMKR						

FIG.5B



SPN	50nm/	LS. 5dB/	RES 5nm	AVR	1	2
KMKR 1378.41nm						
LMKR 0.42dB						

FIG. 6

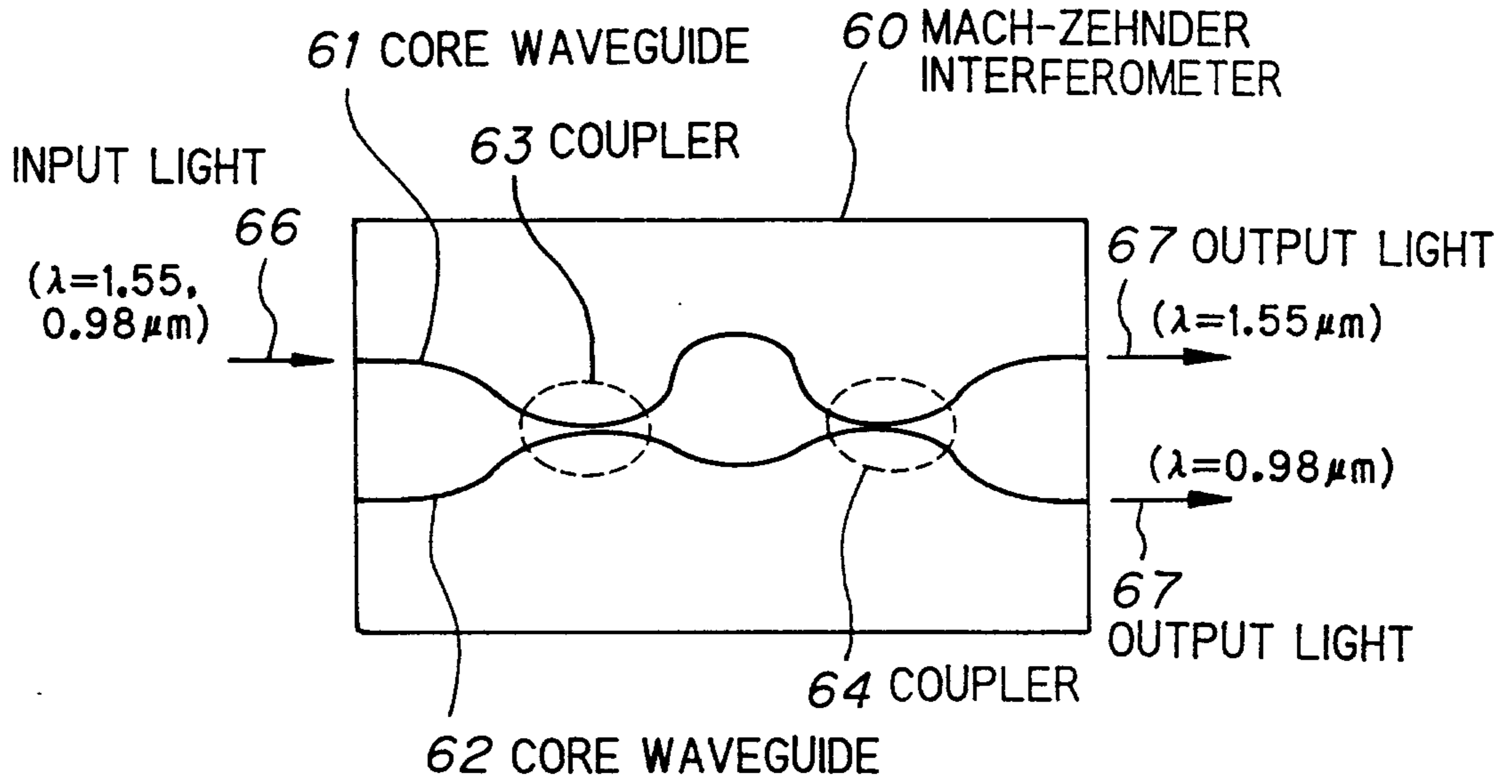
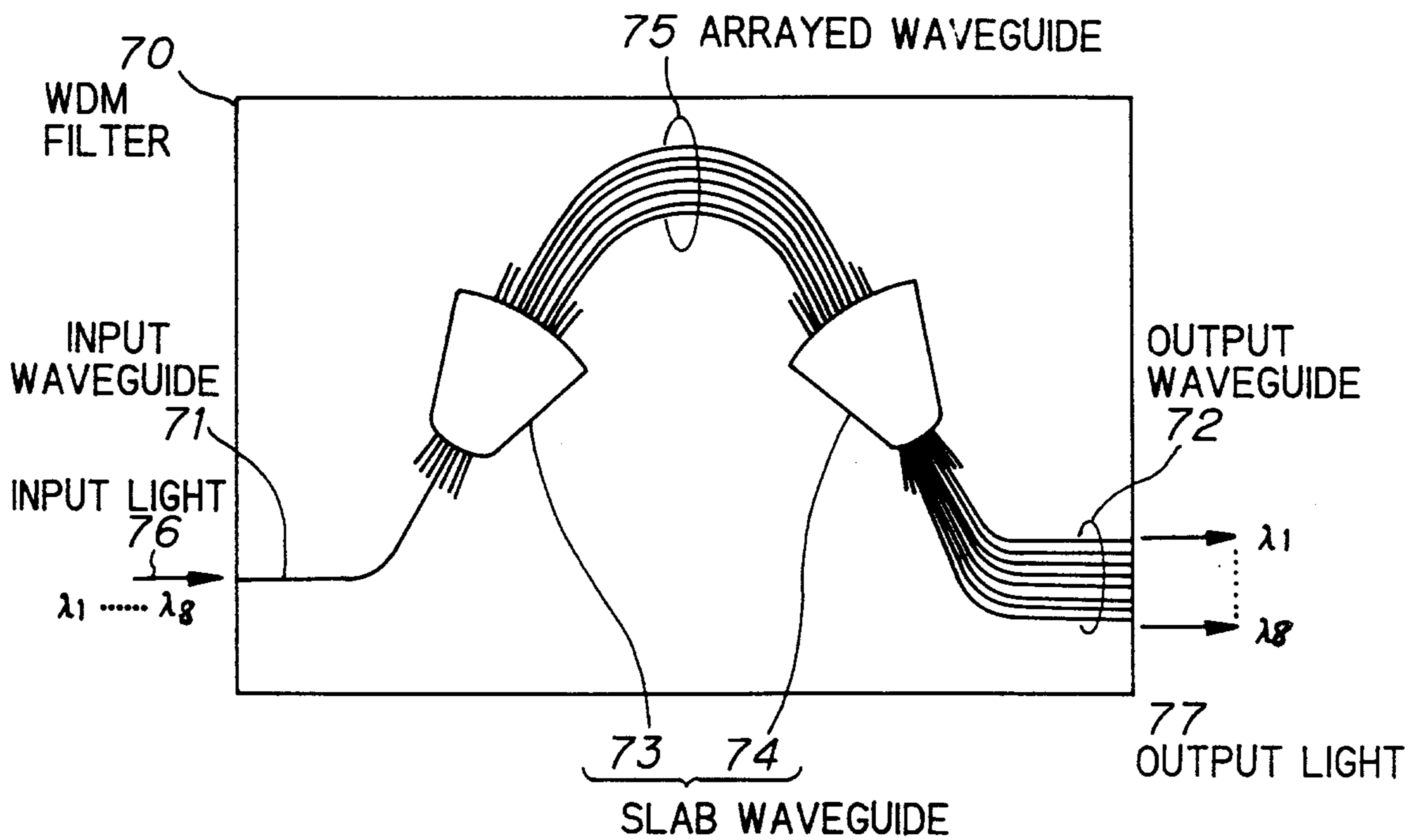

FIG. 7



2 CORE WAVEGUIDE

3 CLADDING LAYER

1 ANHYDROUS SILICA
GLASS SUBSTRATE

