

March 1, 1938.

O. L. STARR

2,109,785

FUEL PUMP

Filed May 1, 1934

FIG. 1.

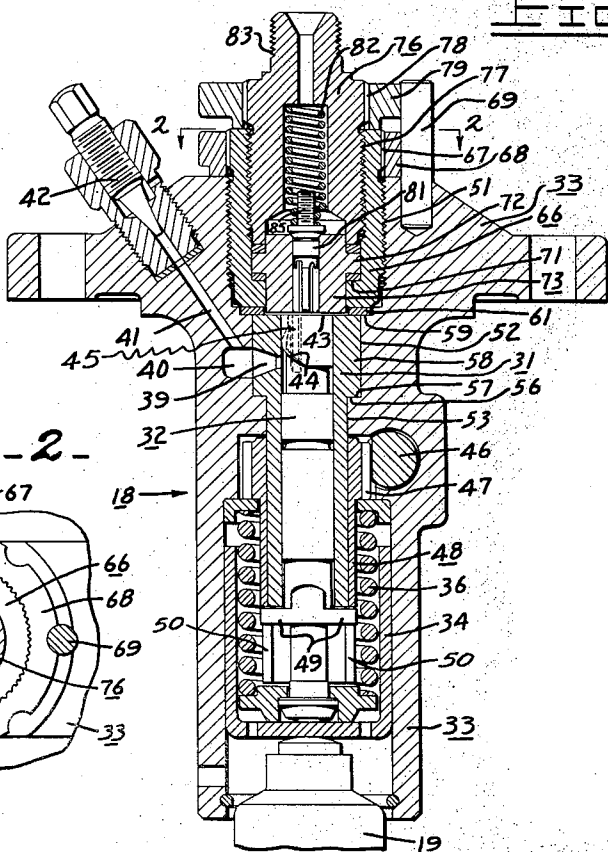

FIG. 2.

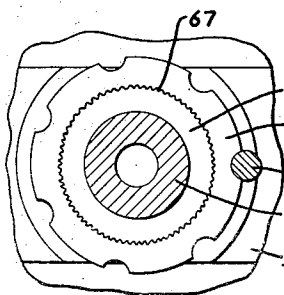

FIG. 3.

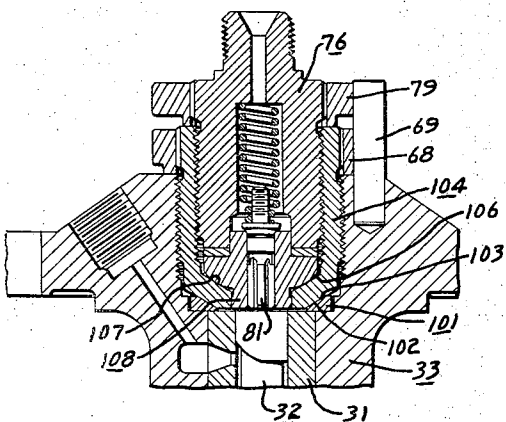
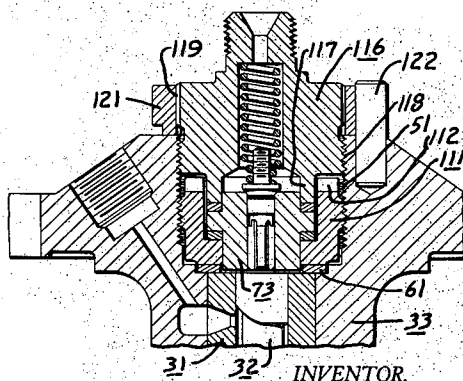

FIG. 4.



INVENTOR
Oscar L. Starr
BY *Charles M. Fryer*
ATTORNEY.

UNITED STATES PATENT OFFICE

2,109,785

FUEL PUMP

Oscar L. Starr, Mission San Jose, Calif., assignor
to Caterpillar Tractor Co., San Leandro, Calif.,
a corporation of California

Application May 1, 1934, Serial No. 723,289

4 Claims. (Cl. 103—154)

The present invention relates to compression ignition and the like engines, and more particularly to an improved fuel injection pump construction therefor.

5 It is an object of the invention to provide an improved fuel injection pump construction which promotes ease of assembly and disassembly of parts.

Another object of the invention is to provide 10 an improved fuel injection pump construction of the type having a cylinder insert for the pump body to form the pump-cylinder or barrel, in which the cylinder is first assembled with respect to the body and then secured therein, after 15 which other parts can be assembled or disassembled without disturbing the cylinder.

Another object of the invention is to provide an improved mounting for a fuel injection pump cylinder or barrel which provides for preadjustment of the forces thereon, irrespective of connection or disconnection of the fuel conduits to the pump.

Another object of the invention is to provide 25 an improved fuel injection pump construction, in which the necessary assembly or disassembly of parts for servicing in the field will not disturb the adjustment of certain preadjusted parts thereof.

An additional object of the invention is the 30 provision of improved mounting means for the discharge valve fitting of a fuel injection pump, which is of such character as to minimize the transmission of fastening stresses to the discharge valve.

35 A further object of the invention is the provision of improved means for holding the pump cylinder or barrel in position, independently of the means for holding the discharge valve fitting which is mounted adjacent the discharge end of the pump cylinder.

40 Other objects will appear as the description progresses.

Description of figures

45 Fig. 1 is a vertical transverse section of a fuel injection pump constructed according to the instant invention, the section being taken through the axis of the pump cylinder.

Fig. 2 is a horizontal sectional view taken in a 50 plane indicated by the line 2—2 in Fig. 1.

Fig. 3 is a fragmentary sectional view similar to Fig. 1 illustrating a second form of the invention.

55 Fig. 4 is a fragmentary sectional view similar to Fig. 1 illustrating a third form of the invention.

Description of mechanism

The present invention is particularly adapted for use in compression ignition and the like engines employing a fuel system of the solid injection type. In a fuel system of this type, fuel, unmixed with air, is injected into a combustion space in an atomized state by the fuel injection nozzle.

A fuel injection pump 18 is utilized to inject 10 the fuel. Parts of the pump proper comprise a cylinder insert in the form of sleeve or barrel 31 (Fig. 1) and a plunger or piston 32 closely fitted to reciprocate and rotate within sleeve 31. Barrel 31 is mounted in pump body 33 in a 15 manner later described. To provide for reciprocation of plunger 32, the lower end thereof projects without sleeve 31 into guide cup 34, slidably mounted within body 33 and having its lower end engaged by the upper part of tappet 20 mechanism 19. Spring 36 serves to impart the suction stroke to plunger 32; while tappet mechanism 19 provides the plunger discharge stroke.

During reciprocation of plunger 32, the angularly adjusted or rotated position thereof 25 determines the quantity of fuel metered by the pump. For this purpose, plunger 32 is provided at its head with valve means to control the opening and closing of a fuel inlet and by-pass port to regulate the quantity of fuel injected. Sleeve 31 has port 39 communicating with fuel inlet 30 passage 40 in body 33, to which passage fuel is supplied under low pressure from a suitable source (not shown). Passage 41 leads from passage 40 to air vent valve 42 of any suitable construction. Plunger 32 has leading or top edge 35 43, and scroll or by-pass edge 44 spaced therefrom and connected by a slot 45 with leading edge 43, to control opening and closing of port 39. The angularly adjusted or rotated position of plunger 32, therefore, serves to determine 40 the part of scroll edge 44 which becomes active with respect to port 39, and thereby controls the quantity of fuel injected by plunger 32 before by-passing occurs. Angular adjustment or rotation of plunger 32 while it reciprocates, is 45 accomplished by slidably mounted, governor controlled rack 46 engaged with gear portion 47 on sleeve 48 which is journaled about plunger barrel 31. Sleeve 48 is slidably and non-rotatably engaged with plunger 32 by means of oppositely 50 extending plunger ears or lugs 49 extending into diametrically opposite elongated slots 50 formed in sleeve 48.

The previously described construction is well 55

known and is, hence, referred to generally. For a more complete description, reference is made to assignee's co-pending application by Carl G. A. Rosen, Serial No. 691,640, filed September 30, 1933.

From the preceding description, it will be apparent that the fit of plunger 32 within sleeve 31 is of great importance for accurate metering of fuel. In actual practice, these parts are lap fitted so that any clearance which exists is in the magnitude of from 2 to 3 one hundred thousandths (.00002-.00003) of an inch. Because of this close fit, care should be taken to prevent distortion of the inner surface of the plunger barrel 31, so as to provide for free and unimpeded operation of the plunger. It is, therefore, important that sleeve 31 be mounted in body 33 in a manner which will preclude any possible distortion thereof which would interfere with operation of pump plunger 32. It is also important that a true cylindrical contour of the inner surface of the cylinder be maintained so that no space can exist between sleeve 31 and plunger 32 to receive any fine particles of foreign abrasive material which might be in the fuel.

To obtain the desirable conditions noted in the preceding paragraph and to, thereby, insure proper operation of the pump, sleeve 31 is mounted in body 33, by fastening means which precludes transmission of distorting stresses to the inner surface of the sleeve and which, after once fastened, allows for assembly or disassembly of other parts without interfering with the secured position of the sleeve. Such means will now be described. Sleeve or barrel 31 (Fig. 1) is insertable through the top of pump body 33 which is provided with a central passage having portions 51, 52 and 53 of differing diameters to receive sleeve 31 and the securing means therefor. Sleeve 31 has a comparatively thick top wall part and a thinner lower wall part forming shoulder 56 therebetween, which seats against shoulder 57 formed between portions 52 and 53 in body 33. Relatively thick top sleeve portion 58 above sleeve shoulder 56 provides a spacing and supporting head for the sleeve. Head portion 58 of the sleeve fits snugly within passage portion 52 and extends only an extremely slight distance above shoulder 59 formed between passage portions 51 and 52 of body 33. Metallic gasket 61 overlaps shoulder 59 and the outer peripheral portion of head 58, and is engaged by the bottom end of the sleeve-fastening nut member 66 which is externally threaded to screw into threads formed in passage portion 51.

It will be noted that annular gasket 61 is positioned directly over sleeve shoulder 56; and since gasket 61 overlaps only the outer peripheral part of the top edge of sleeve head 58, nut 66, when screwed to a suitable preadjusted position, clamps sleeve 31 in body 33 in a manner to transmit clamping stresses away from the inner surface of the sleeve to thereby preclude distortion of the cylindrical sleeve surface which cooperates with plunger 32. Furthermore, since the gasket 61 overlaps both the shoulder 59 and the outer peripheral portion of the head 58, an efficacious arrangement obtains for precluding leakage of fuel upwardly between the head 58 of the plunger sleeve and the body 33. Above body 33 (Figs. 1 and 2), nut member 66 is provided with peripheral serrations or splines 67 engaged by internally serrated or splined lock nut 68. Nut 68 is secured against rotation with respect to body 33 by dowel pin 69 which is removably seated in

body 33, and engages a suitably peripheral recessed portion of nut 68. Thus, after the proper degree of clamping pressure has been applied by nut 66 to hold sleeve 31 in position, nut 66 can be fixedly held by slipping nut 68 in engagement therewith in a proper selected position, and then by holding the entire assembly against rotation by dowel pin 69.

Nut 66, which serves alone to hold sleeve 31 in place, is hollow to provide also a mounting for a discharge valve communicating with the pump cylinder, whereby the valve mounting can be assembled and disassembled independently of the mounting of sleeve 31. With reference to Fig. 1, it will be observed that a shoulder 71, extending inwardly from the lower edge of nut 66 is overlapped by annular flange 72 formed between the ends of removably secured valve cage 73; a suitable gasket being interposed between shoulder 71 and flange 72. Flange 72 serves as a seat for fuel discharge valve fitting or cage 73, which is held in position by hollow retainer nut or bonnet 76, screwed into nut 66 and having its lower edge abutting a suitable gasket resting on the top of flange 72. Bonnet 76 is peripherally serrated or splined at 78 for engagement with interiorly splined lock nut 79, which is similar to nut 68 and is similarly held against rotation by pin 69. A central passage formed within valve cage 73 is normally closed by valve 81 under the pressure of spring 82 seated within a central passage in bonnet 76. At its upper end, bonnet 76 is threaded at 83 to receive the fastening means for a fuel discharge conduit.

From the foregoing description, it is seen that sleeve 31 forming the pump cylinder is mounted in preadjusted condition with respect to the pump body 33, so that it is securely held in place without being subjected to any stresses which would cause distortion thereof. It is further seen that the valve means 73, 81, bonnet 76 and conduit 17 can be assembled or disassembled from pump body 33 without disturbing the adjusted condition of sleeve 31. Also, because less pressure is necessary to hold valve cage 73 in place than is required to hold sleeve 31, and because bonnet or nut 76 serves to clamp cage 73 in place at the peripheral flange 72, no distorting stresses are transmitted to valve 81, thereby avoiding binding of the valve. A threaded stem 85 is formed on the top of valve 81 to permit engagement thereof with a suitable threaded instrument for enabling removal of valve 81 alone when this is desired.

Fig. 3 illustrates a modified construction which is generally similar in principle to that disclosed in Fig. 1, and will be described only insofar as it differs therefrom; like numbers being used to refer to like parts.

Sleeve 31 is held in body 33 by metallic gasket 101 having upper frusto-conical seat 102 engaged by corresponding frusto-conical seat 103 or nut member 104. Spaced from and in parallel relation to conical seat 103, nut member 104 has inner frusto-conical seat 106 which is engaged by rounded annular seat or surface 107 on valve cage 108. Valve cage 108 and nut member 104 are otherwise similar to valve cage 73 and nut member 66. Bonnet 76 serves to secure valve cage 108 in position.

Fig. 4 illustrates a third form of the invention which is generally similar to those described above. Sleeve 31 is secured, with respect to body 33, by gasket 61 and nut member 111 which has threaded engagement with threaded passage

51 of body 33. At its top, nut member 111 has spaced serrations 112 which can be engaged by a suitable tool to provide for assembly and disassembly thereof in body 33. Valve cage 73 is secured within nut member 111 by bonnet 116 having central cylindrical extension 117 engaging cage 73 and spaced from nut member 111. Bonnet 116 is externally threaded at 118 to engage threaded passage 51 of body 33. Without casing 33, bonnet 116 is serrated at 119 to engage internally serrated lock nut 121, which is secured against rotation with respect to body 33 by dowel pin 122.

I, therefore, claim as my invention:

1. In a fuel injection pump, a pump body having a passage with portions of differing diameters, an end portion being threaded, shoulders on said body between said passage portions, a barrel insert in said body having a head forming a shoulder, said head shoulder engaging one of said body shoulders with said head terminating adjacent another of said body shoulders, a gasket overlapping said head and said another shoulder, a hollow nut member externally threaded to engage said threaded passage portion and having an end engaging said gasket, a seat formed within said nut member, a valve fitting member removably mounted in said nut member and having a seat supported by said nut member seat, a valve mounted on said valve fitting member, and a retainer nut having an end thrusting against said valve fitting member for applying clamping pressure to said valve fitting member.

2. In a fuel injection pump, a pump body having a passage with portions of differing diameters, an end portion being threaded, shoulders on said body between said passage portions, a barrel insert in said body having a head forming a shoulder, said head shoulder engaging one of said body shoulders with said head terminating adjacent and projecting slightly beyond another of said body shoulders, a gasket overlapping said head and said another shoulder, a hollow nut member externally threaded to engage said threaded passage portion and having an end engaging said gasket, internal threads on said nut member, a seat formed within said nut member, a valve fitting member removably mounted in said nut member and having a seat supported

by said nut member seat, a valve mounted on said valve fitting member, and a retainer nut having an end thrusting against said valve fitting member for applying clamping pressure to said valve fitting member and having threads engaging said nut member threads.

3. In a fuel injection pump, a pump body having a central passage with portions of differing diameters, an end portion being threaded, shoulders on said body between said passage portions, a barrel insert in said body having a head forming a shoulder, said head shoulder engaging one of said body shoulders with said head terminating adjacent and projecting slightly beyond another of said body shoulders, a gasket overlapping said head and said another shoulder, a nut member externally threaded to engage said threaded bore portion and having an end engaging said gasket, a seat formed within said nut member, a valve fitting member removably mounted in said nut member and having a seat supported by said nut member seat, a valve mounted on said valve fitting member, and a retainer nut for said valve fitting member and having external threads engaging said threaded bore portion.

4. In a fuel injection pump, a pump body having a central passage with portions of differing diameters, an end portion being threaded, shoulders on said body between said passage portions, a barrel insert in said body having a head forming a shoulder, said head shoulder engaging one of said body shoulders with said head terminating adjacent and projecting slightly beyond another of said body shoulders, a gasket overlapping said head and said another shoulder, a nut member externally threaded to engage said threaded bore portion and having an end engaging said gasket to hold said barrel in a suitable preadjusted position, a seat formed within said nut member, a valve fitting member removably mounted in said nut member and having a seat supported by said nut member seat, a valve mounted on said valve fitting member, and a retainer nut for said valve fitting member, said valve fitting member and said valve being removable from within said nut member without disturbing said preadjusted position of said barrel.

OSCAR L. STARR.