



(12) **DEMANDE DE BREVET CANADIEN
CANADIAN PATENT APPLICATION**

(13) **A1**

(86) Date de dépôt PCT/PCT Filing Date: 2018/11/21
 (87) Date publication PCT/PCT Publication Date: 2019/11/28
 (85) Entrée phase nationale/National Entry: 2020/05/19
 (86) N° demande PCT/PCT Application No.: US 2018/062353
 (87) N° publication PCT/PCT Publication No.: 2019/226194
 (30) Priorité/Priority: 2017/11/22 (US62/590,153)

(51) Cl.Int./Int.Cl. *G01S 13/90* (2006.01)
 (71) Demandeur/Applicant:
URTHECAST CORP., CA
 (72) Inventeurs/Inventors:
FOX, PETER ALLEN, CA;
CHISHOLM, TODD THOMAS, CA;
NUTINI, JULIE, CA;
DE VOS, JAKLYN MICHELE, CA
 (74) Agent: NORTON ROSE FULBRIGHT CANADA
LLP/S.E.N.C.R.L., S.R.L.

(54) Titre : APPAREIL FORMANT RADAR A OUVERTURE SYNTHETIQUE ET PROCEDES ASSOCIES
 (54) Title: SYNTHETIC APERTURE RADAR APPARATUS AND METHODS

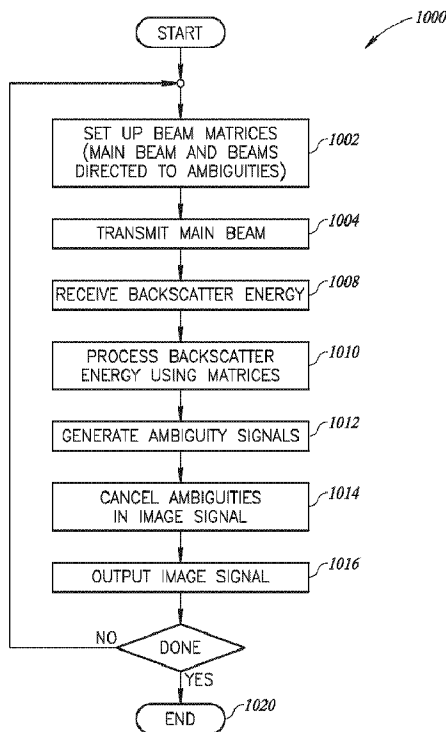

FIG. 10

(57) **Abrégé/Abstract:**

A synthetic aperture radar (SAR) system generates an image of a first swath. The SAR includes at least one SAR antenna, at least one SAR processor and at least one SAR transceiver. In operation the SAR defines a first beam to illuminate the first swath and

(57) **Abrégé(suite)/Abstract(continued):**

one or more second beams to illuminate area(s) of ambiguity associated with the first beam. The SAR transmits a pulse via the first beam and receives backscatter energy. The SAR generates a first signal associated with the first beam and one or more second signals associated with the second beam(s). The second signal(s) are combined with determined complex vector(s), generating ambiguity signal(s) and the ambiguity signals are combined with the first signal to generate an image associated with the first swath.

(12) INTERNATIONAL APPLICATION PUBLISHED UNDER THE PATENT COOPERATION TREATY (PCT)

(19) World Intellectual Property Organization
International Bureau



(10) International Publication Number
WO 2019/226194 A3

(43) International Publication Date
28 November 2019 (28.11.2019)

- (51) International Patent Classification:
G01S 13/90 (2006.01)
- (21) International Application Number:
PCT/US2018/062353
- (22) International Filing Date:
21 November 2018 (21.11.2018)
- (25) Filing Language: English
- (26) Publication Language: English
- (30) Priority Data:
62/590,153 22 November 2017 (22.11.2017) US
- (71) Applicant: **URTHECAST CORP.** [CA/CA]; 1055 Canada Place, Suite 33, Vancouver, British Columbia V6C 0C3 (CA).
- (72) Inventors: **FOX, Peter, Allen**; 3756 Edinburgh Street, Burnaby, British Columbia V5C 1R5 (CA). **CHISHOLM, Todd, Thomas**; 2761 Eton Street, Vancouver, British Columbia V5K 1K2 (CA). **NUTINI, Julie**; #602-2323 West 2nd Avenue, Vancouver, British Columbia V6K 1J4 (CA). **DE VOS, Jaklyn, Michele**; #602-2323 West 2nd Avenue, Vancouver, British Columbia V6K 1J4 (CA).

(74) Agent: **BOLLER, Timothy, L.** et al.; Seed Intellectual Property Law Group LLP, Suite 5400, 701 Fifth Avenue, Seattle, WA 98104-7064 (US).

(81) Designated States (unless otherwise indicated, for every kind of national protection available): AE, AG, AL, AM, AO, AT, AU, AZ, BA, BB, BG, BH, BN, BR, BW, BY, BZ, CA, CH, CL, CN, CO, CR, CU, CZ, DE, DJ, DK, DM, DO, DZ, EC, EE, EG, ES, FI, GB, GD, GE, GH, GM, GT, HN, HR, HU, ID, IL, IN, IR, IS, JO, JP, KE, KG, KH, KN, KP, KR, KW, KZ, LA, LC, LK, LR, LS, LU, LY, MA, MD, ME, MG, MK, MN, MW, MX, MY, MZ, NA, NG, NI, NO, NZ, OM, PA, PE, PG, PH, PL, PT, QA, RO, RS, RU, RW, SA, SC, SD, SE, SG, SK, SL, SM, ST, SV, SY, TH, TJ, TM, TN, TR, TT, TZ, UA, UG, US, UZ, VC, VN, ZA, ZM, ZW.

(84) Designated States (unless otherwise indicated, for every kind of regional protection available): ARIPO (BW, GH, GM, KE, LR, LS, MW, MZ, NA, RW, SD, SL, ST, SZ, TZ, UG, ZM, ZW), Eurasian (AM, AZ, BY, KG, KZ, RU, TJ, TM), European (AL, AT, BE, BG, CH, CY, CZ, DE, DK, EE, ES, FI, FR, GB, GR, HR, HU, IE, IS, IT, LT, LU, LV, MC, MK, MT, NL, NO, PL, PT, RO, RS, SE, SI, SK, SM, TR), OAPI (BF, BJ, CF, CG, CI, CM, GA, GN, GQ, GW, KM, ML, MR, NE, SN, TD, TG).



WO 2019/226194 A3

(54) Title: SYNTHETIC APERTURE RADAR APPARATUS AND METHODS

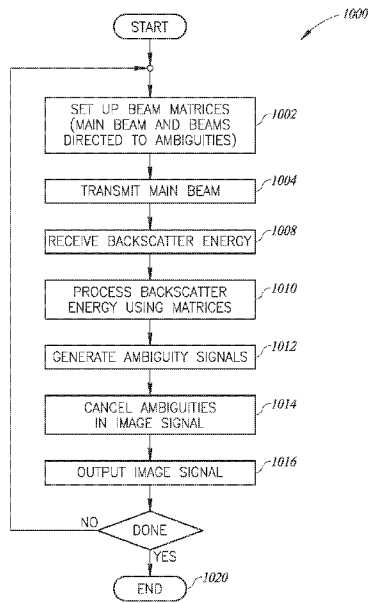

FIG. 10

(57) Abstract: A synthetic aperture radar (SAR) system generates an image of a first swath. The SAR includes at least one SAR antenna, at least one SAR processor and at least one SAR transceiver. In operation the SAR defines a first beam to illuminate the first swath and one or more second beams to illuminate area(s) of ambiguity associated with the first beam. The SAR transmits a pulse via the first beam and receives backscatter energy. The SAR generates a first signal associated with the first beam and one or more second signals associated with the second beam(s). The second signal(s) are combined with determined complex vector(s), generating ambiguity signal(s) and the ambiguity signals are combined with the first signal to generate an image associated with the first swath.

WO 2019/226194 A3 

Declarations under Rule 4.17:

- *as to the applicant's entitlement to claim the priority of the earlier application (Rule 4.17(iii))*

Published:

- *with international search report (Art. 21(3))*
- *before the expiration of the time limit for amending the claims and to be republished in the event of receipt of amendments (Rule 48.2(h))*

(88) Date of publication of the international search report:

30 January 2020 (30.01.2020)

SYNTHETIC APERTURE RADAR APPARATUS AND METHODS

TECHNICAL FIELD

[0001] The present application relates generally to a synthetic aperture radar
5 (SAR) and, more particularly, to a SAR providing Quad Polarization (Quad Pol)
functionality.

BACKGROUND

Description of the Related Art

[0002] A synthetic aperture radar (SAR) is an imaging radar. The SAR exploits
10 the relative motion of the radar and a target of interest to obtain high azimuthal
resolution. The SAR is typically flown on an aircraft, a spacecraft, unmanned
aerial vehicle (UAV) such as a drone, or another suitable platform. The target
of interest is typically on the ground (e.g. on land, water, ice or snow), and can
be a point target or a distributed target. The SAR can be a component of a SAR
15 imaging system, the system also including at least one of data processing and
data distribution components.

[0003] In conventional operation of a SAR imaging system, the system is tasked
to obtain images of a target or a swath. Data is collected on-board the platform.
In the case of a spaceborne SAR, the data is collected on-board the spacecraft,
20 and either processed on-board the spacecraft and downlinked to the ground, or
downlinked and processed on the ground to generate the images. The images
are distributed to the user, typically via a network. In some implementations, the
main elements of a space-borne SAR platform can include:

- Satellite Platform: includes the following subsystems and
25 units: Structure, Power, On-board Data Handling, a Payload
Data Handling Unit, Telemetry and Telecommands;

- Communications (TT&C), X-Band High-rate Downlink, Attitude and Orbit Control subsystem, Thermal Control, and Propulsion;
- SAR Instrument; and/or
- 5 • A SAR Processing Unit: performs onboard SAR data processing.

[0004] A single frequency SAR generates images of the terrain by transmitting radar pulses in a frequency band centered on a single frequency. For example, in the case of the RADARSAT-2 SAR, the center frequency was 5.405GHz.

10 [0005] Having SAR images acquired at the same time at different frequency bands can be beneficial for remote sensing of the terrain. For example, longer wavelengths (such as L-band) propagate better through vegetation and can provide backscatter from stems or branches, or from the ground below. Shorter wavelengths (such as X-band) tend to provide more backscatter from the canopy. Simultaneous acquisition of SAR images at more than one frequency of illumination (for example, at L-band and X-band) can provide a more complete understanding of the terrain than acquisition of images at a single band.

15 [0006] It can also be desirable for the SAR to be capable of imaging at different polarizations (for example, single polarization and quad polarization), and in different operational modes such as ScanSAR and spotlight SAR.

BRIEF SUMMARY

20 [0007] Some embodiments of SAR systems can incorporate the following advanced SAR features into a single SAR instrument:

- 25 • a shared aperture;
- multi-aperture (e.g., in one implementation, six apertures for a SAR operating at X-band, three apertures for a SAR operating at L-band);
- digital beam-forming (with multiple beams in elevation and azimuth);

30

- quad-polarization and compact polarization; and/or
- modular multi-aperture technology with digital interfaces of SAR Data.

[0008] In the case of a dual-band SAR, the SAR can have simultaneous dual-
5 frequency capability (*e.g.*, L-band and X-band).

[0009] SAR systems can include multiple digital and RF components. In some implementations, a SAR system includes a SAR antenna, sensor electronics, and Transmit Receive Modules (TRMs) mounted on an antenna panel.

[0010] A SAR Processing Unit (SPU) can be part of an On-Board Data
10 Handling subsystem. The SPU may house processing boards, power boards, cabling, and an associated backplane. Each processing board in the SPU can include multiple ultra-high performance FPGA boards, for example, that can perform real-time processing tasks. The processing functions performed by the SPU can include the following:

- 15
- on-board SAR Data Processing;
 - target detection; and/or
 - compression/packetization/encryption/forward error correction encoding for communications links.

[0011] In an embodiment, a method of operation of a synthetic aperture radar
20 (SAR) system comprising at least one SAR antenna, at least one SAR processor and at least one SAR transceiver, includes: defining a first beam to illuminate a first swath using the at least one SAR antenna; defining a second beam to illuminate a first area of ambiguity associated with the first beam; transmitting a pulse via the first beam and receiving backscatter energy; generating, by the at
25 least one SAR processor based on the received backscatter energy, a first signal associated with the first beam and a second signal associated with the second beam; combining the second signal with a first determined complex vector, generating a first ambiguity signal; and combining the first signal with the first ambiguity signal, generating an image signal associated with the first swath. In
30 an embodiment, the method includes defining a third beam to illuminate a second area of ambiguity associated with the first beam; generating, by the at

least one SAR processor based on the received backscatter energy, a third signal associated with the third beam; combining the third signal with a second determined complex vector, generating a second ambiguity signal; and combining the first signal with the first ambiguity signal and the second ambiguity signal, generating the image signal associated with the first swath.

[0012] In an embodiment, a method of operation of a synthetic aperture radar (SAR) system comprising at least one SAR antenna, at least one SAR processor and at least one SAR transceiver, includes: defining a first beam to illuminate a first swath using the at least one SAR antenna; defining a plurality of second beams to illuminate respective areas of ambiguity associated with the first beam; transmitting a pulse via the first beam and receiving backscatter energy; generating, by the at least one SAR processor and based on the backscatter energy, a first signal associated with the first beam and a plurality of second signals associated with respective beams of the plurality of second beams; combining the signals of the plurality of second signals with respective determined complex vectors, generating a plurality of ambiguity signals; and combining the first signal with the plurality of ambiguity signals, generating an image signal associated with the first swath. In an embodiment, a determined complex vector represents a ratio of a complex sensitive of the first beam to a complex sensitivity of a beam illuminating an area of ambiguity associated with the first beam. In an embodiment, the beams are multiple simultaneous elevation beams. In an embodiment, the beams are formed from an aperture. In an embodiment, the method includes operating the SAR in a Quad-Pol mode. In an embodiment, defining a beam to illuminate an area of ambiguity associated with the first beam comprises directing the beam based on one or more of: a beam center offset; or beam pattern shaping. In an embodiment, the method includes directing beams at non-sequential areas of ambiguity associated with the first beam. In an embodiment, the combining the first signal with an ambiguity signal at least partially cancels ambiguous energy present in the first signal. In an embodiment, the combining the first signal with an ambiguity signal comprises applying linear algebra. In an embodiment, the combining the

first signal with an ambiguity signal comprises subtracting the ambiguity signal from the first signal. In an embodiment, the SAR comprises multiple overlapping or non-overlapping azimuth apertures and the method comprises using azimuth modulation. In an embodiment, the method includes using
5 alternating up/down chirp modulation. In an embodiment, the method includes using a multi-polarization mode with 5 beams receiving backscatter energy at each polarization. In an embodiment, the SAR operates in an L-band. In an embodiment, the method includes estimating a calibration error associated with a ratio of complex sensitive and compensating for the calibration error. In an
10 embodiment, the ambiguity is a range ambiguity located on a main lobe of the first beam. In an embodiment, the range ambiguities are measured on backscatter of the pulse transmitted on the first beam.

[0013] In an embodiment, a synthetic aperture radar (SAR) system includes at least one SAR antenna, at least one SAR processor and at least one SAR
15 transceiver, and the SAR system is operable to perform any of the methods disclosed herein. In an embodiment, the at least one SAR antenna, the at least one SAR processor and the at least one SAR transceiver are co-located on a spaceborne or airborne SAR platform. In an embodiment, the spaceborne SAR platform is a free-flying spacecraft.

20 BRIEF DESCRIPTION OF THE SEVERAL VIEWS OF THE DRAWINGS

[0014] In the drawings, identical reference numbers identify similar elements or acts unless the context indicates otherwise. The sizes and relative positions of elements in the drawings are not necessarily drawn to scale. For example, the shapes of various elements and angles are not necessarily drawn to scale, and
25 some of these elements may be arbitrarily enlarged and positioned to improve drawing legibility. Further, the particular shapes of the elements as drawn, are not necessarily intended to convey any information regarding the actual shape of the particular elements, and may have been solely selected for ease of recognition in the drawings.

[0015] FIG. 1 is a graph illustrating example range ambiguity positions and levels.

[0016] FIGS. 2A-2D illustrate a simulation result of alternating up/down chirps.

[0017] FIG. 3 shows an example modulation signal applied in the simulation of
5 FIG. 2.

[0018] FIG. 4 is a graph illustrating example range ambiguity positions and levels.

[0019] FIGS. 5A and 5B are black and white and color graphs illustrating
example two-way beam patterns and ambiguous two-way beam patterns of an
10 embodiment.

[0020] FIGS. 6A, 6B, 7A and 7B are black and white and color graphs
illustrating an embodiment of using independent digitally beam-formed beams
to reduce range ambiguities.

[0021] FIG. 8 is a block diagram of a SAR system, in accordance with the
15 systems and methods of the present application.

[0022] Fig. 9 shows an example efficient planar phased array antenna assembly,
in accordance with the systems and methods described in the present application.

[0023] FIG. 10 is a flow chart illustrating a method of operation of a SAR (such
as the SAR of FIG. 8) in accordance with the systems and methods described in the
20 present application.

DETAILED DESCRIPTION

[0024] Unless the context requires otherwise, throughout the specification and
claims which follow, the word "comprise" and variations thereof, such as,
"comprises" and "comprising" are to be construed in an open, inclusive sense,
25 that is as "including, but not limited to."

[0025] Reference throughout this specification to "one implementation" or "an
implementation" or "one embodiment" or "an embodiment" means that a
particular feature, structure or characteristic described in connection with the
implementation or embodiment is included in at least one implementation or at
30 least one embodiment. Thus, the appearances of the phrases "one

implementation” or “an implementation” or “in one embodiment” or “in an embodiment” in various places throughout this specification are not necessarily all referring to the same implementation or the same embodiment. Furthermore, the particular features, structures, or characteristics may be combined in any
5 suitable manner in one or more implementations or one or more embodiments.

[0026] As used in this specification and the appended claims, the singular forms “a,” “an,” and “the” include plural referents unless the content clearly dictates otherwise. It should also be noted that the term “or” is generally employed in its
10 broadest sense, that is as meaning “and/or” unless the content clearly dictates otherwise.

[0027] The Abstract of the Disclosure provided herein is for convenience only and does not interpret the scope or meaning of the embodiments.

[0028] As used herein, and in the claims, cueing means the scheduling and commanding of an activity such as the pointing of a remote sensing instrument
15 (such as a SAR) and/or acquisition of data using the remote sensing instrument.

[0029] As used herein, and in the claims, self-cueing means the cueing of a remote sensing instrument in response to information derived from data previously acquired by the same remote sensing instrument.

[0030] As used herein, and in the claims, pre-steered beam means a steered
20 beam of an antenna for which the value of the steering angle depends at least in part on fixed or permanent elements introduced during manufacture of the antenna that cause the beam to be steered to a selected angle.

[0031] Synthetic aperture radars suffer from the problem of range ambiguities. High range ambiguities are an issue in all radars and may be solved by delaying
25 transmission of a second pulse until all returns from the first pulse have died out. However, this solution may be impractical, for example, in a space-based SAR.

[0032] In space-based SAR the ambiguity problem is complicated by the long range to the ground. The SAR is be sampled in azimuth at a rate somewhat
30 larger than the azimuth Doppler bandwidth. Azimuth Doppler bandwidth can be reduced by increasing the azimuth dimension (along track) of the physical

antenna aperture. Decreasing the azimuth sampling rate, that is, the pulse repetition frequency (PRF), increases the spacing between the range ambiguities, and the range ambiguity level is decreased as the ambiguities move further away from the peak of the antenna. Unfortunately, the reduction in azimuth Doppler bandwidth results in poor azimuth resolution. Similarly, the reduction in PRF has the potential to increase azimuth ambiguities.

5 [0033] In FIG. 1, we see the range ambiguity positions and levels for a PRF of 3500Hz (L-Band 6m x 1.8m array). The shaded portions of the curves represent ambiguous signals, with the exception of the shaded portion on the peak of the main beam, which is the part of the beam pattern that is used for imaging. As illustrated, the peak ambiguity levels are well above -20dB.

10 [0034] Increasing the PRF results in increased range ambiguities, since the ambiguities move closer to the main lobe of the antenna (in elevation). Note in FIG. 1 that the +1 and -1 ambiguities (immediately to the right and left, respectively, of the main beam) are *on* the main beam itself. This is typical behavior when the PRF has been forced to a higher frequency due to quad-pol and a broad elevation beam. It is difficult to reduce these ambiguities by manipulating the beam pattern because the main beam elevation roll-off rate is determined by the height of the real aperture. If the physical aperture of the antenna in elevation can be increased, then the main lobe would become narrower and these ambiguities would remain in the same angular position but would be reduced in strength. However, the physical size of the antenna is a powerful cost driver of the entire SAR system, and thus, a larger antenna may not always be a feasible solution.

15 [0035] The problem of range ambiguities may be greatly exacerbated by lower frequency SARs. For example, an L-band SAR has a beam pattern that is 8 times wider than an X-band SAR of the same physical dimensions. Note that SAR is of unparalleled utility in global biomass and biosphere studies, and the quality of the scientific data is greatly enhanced by using lower frequencies and using quad-pol. Thus, the problem of high range ambiguities is of significant importance in such studies.

[0036] The classic method for controlling range (and azimuth) ambiguities is to use a large antenna (large area) or a multi-aperture antenna. An embodiment provides algorithms and technologies to facilitate reducing range ambiguities and enabling smaller satellites platforms to deliver high quality products providing polarization functionality.

[0037] Most spaceborne SAR antennas are very large, with a range from 9 to 15m being typical for the antenna length (along track dimension). For example, RADARSAT-2 has an antenna that is 15m long; ALOS-2 has an antenna of 9.9m; and Tandem-L has a proposed 15m diameter SAR antenna.

[0038] Spaceborne SARs are thus some of the largest structures flown in space. Spaceborne SARs employ complex deployment mechanisms, and even when the antenna is stowed for launch, the mass of the large antenna needs to be tied down and supported by a large bus. The result is that the launch requires a large launch vehicle.

[0039] It is possible to make smaller SARs with acceptable performance. Example compromises of doing so are discussed in A. Freeman et al., *The "Myth" of the Minimum SAR Antenna Area Constraint*, Geosci. and Remote Sensing, 38 (2000), in which it is shown that smaller SAR antennas are practicable and offer the SAR system designer a greater degree of freedom in system design. The ability to use smaller SAR systems rests on three insights into spaceborne SAR design that have each been implemented successful.

[0040] The three insights are:

- selection of a pulse repetition frequency (PRF) smaller than the nominal Doppler bandwidth;
- adoption of a smaller processing bandwidth;
- limiting the appearance of range ambiguities by the selection of a data-window size in a range that is less than the illuminated swath.

[0041] However, when quad-pol functionality (and performance) is desired, then the first of these insights is violated, and the PRF has to be doubled. As a

consequence of this, range ambiguities become a problem once again, which conventionally is addressed by employing larger antennas or multiple apertures.

[0042] Conventional quad-pol SARs, (see, e.g., Werninghaus et al., *The TerraSAR-X Mission*, Proceedings of EUSAR 2004 (May 2004), Lombardo et al., *Monitoring and surveillance potentialities obtained by splitting the antenna of the COSMO-SkyMed SAR into multiple sub-aperture*, IEEE Proceedings on Radar, Sonar and Navigation, 153 (2) (2006)) operate with interleaved transmission of alternate H- and V-polarized pulses, receiving both H- and V-polarizations to build up a measurement of the full scattering matrix for each pixel on the ground.

[0043] In quad-pol mode, the SAR designer typically adopts an overall PRF that is twice as high as for conventional non-quad-pol modes of operation, interleaving H and V transmit pulses, and receiving both H and V-polarized returns for each. One limitation to such systems has been the presence of strong like-polarized (HH or VV) range ambiguities arriving at the same time as cross-polarized (HV or VH) returns from the desired imaged swath. These ambiguities tend to severely restrict the range of incidence angles and swaths for quad-pol systems.

[0044] Consider the following equation (Eq. 1) for the total measured scattering matrix M of the imaged swath,

$$\begin{pmatrix} M_{HH} & M_{HV} \\ M_{VH} & M_{VV} \end{pmatrix} \cong \begin{pmatrix} S_{HH} & S_{HV} \\ S_{VH} & S_{VV} \end{pmatrix} + \sum_{i=odd} RAR_i \begin{pmatrix} \hat{S}_{HV_i} & \hat{S}_{HH_i} \\ \hat{S}_{VV_i} & \hat{S}_{VH_i} \end{pmatrix} \\ + \sum_{i=even} RAR_i \begin{pmatrix} \hat{S}_{HH_i} & \hat{S}_{HV_i} \\ \hat{S}_{VH_i} & \hat{S}_{VV_i} \end{pmatrix}$$

(Eq. 1)

where the subscript notation $X_{P_1 P_2}$ is used with P_1 denoting the receive (RX) polarization and P_2 denoting the transmit (TX) polarization. Note that Eq. 1 is derived from Raney et al., *Improved Range Ambiguity Performance in Quad-Pol SAR*, IEEE Trans. Geosci. And Remote Sensing, 50 (2) (2102), (mutatus mutandis). In the above notation, the first column of the M matrix is captured

with a horizontally polarized transmit pulse and the second column is captured with a vertically polarized transmit pulse.

[0045] The first term on the right-hand side represents the actual scattering matrix of the desired swath. The remaining two terms in Eq. 1 represent range ambiguities, where we use the ‘ $\hat{\cdot}$ ’ to denote range ambiguous returns. The odd values of i are due to the orthogonal transmit polarization, and the even values of i are due to the same polarization on transmit. Note that the columns of the scattering matrix in the odd-valued range ambiguities are swapped because they arise from alternately transmitted pulses of the opposite polarization.

10 [0046] The main consequence of the second term in Eq. 1 is that because of the higher PRF introduced by interleaving transmit pulses, HV and VH returns of the S matrix are dominated by co-pol ambiguities from the \hat{S} odd ambiguity matrix. These co-pol ambiguities may be 4-10 dB higher than the cross-pol terms in the S matrix. Thus, the very parameter that we are trying to measure, that is, the cross-pol terms of the S matrix, are the worst affected.

[0047] The co-pol terms of the S matrix are less affected, as they are higher than the ambiguous signal from the cross-pol terms.

20 [0048] In general, notwithstanding the effect of incidence angle, the first ambiguities are the strongest and thus, by the above discussion, are the worst contaminants of co-pol ambiguous energy into the desired cross-pol measurement.

[0049] In order to reduce range ambiguities, the ALOS-2 PALSAR-2 system has an ability to send alternating up/down chirp signals. One of the new techniques of ALOS-2 is the chirp modulation, which is used to decrease the influence of point target range ambiguities. ALOS-2 uses up/down chirp signals alternately transmitted with phase modulation (0 or π radians), while PALSAR only uses a down linear chirp.

25 [0050] Consider the following explanation of pulse-to-pulse phase modulation (from A. Doerry, *SAR Ambiguous Range Suppression*, Sandia National Laboratories Report, SAND2006-5332 (2006)):

30

Doppler radar systems such as SAR allow a degree of freedom to separate the desired echo from an undesired ambiguous range echo. A pulse-to-pulse phase modulation can be employed to shift echoes from an undesired range to regions of the Doppler spectrum that facilitate their attenuation by conventional digital filtering techniques. Since the desired range is known, as is its pulse phase modulation, these can be accommodated in a manner so as to have no negative effect for the desired range echo.

Consequently, the desired range is separated in Doppler space from the undesired ambiguous range. This allows the undesired ambiguous range to be suppressed without affecting the desired range echo.

[0051] However, this technique pushes the ambiguous energy into specific areas of the Doppler spectrum with the result that the azimuth Doppler spectrum can no longer be used to achieve maximum azimuth resolution.

[0052] The Japanese Aerospace Exploration Agency (JAXA) has experimentally confirmed that the range ambiguity improved about 10 dB compared to results without any chirp or phase modulation. See Y. Kankaku et al., *The overview of the L-band SAR onboard ALOS-2*, Progress In Electromagnetics Research Symposium Proceedings (Aug. 2009). FIG. 2 shows the simulation result of alternating up/down chirps. FIG. 3 shows the modulation signal applied in Fig. 2. FIG. 2(a) illustrates the main signal and FIG. 2(b) illustrates the ambiguity signal. The simulation area is TOMAKOMAI and the data is Pi-SAR data, which is the airborne L-band SAR. FIG. 2(c) illustrates where the signals of FIG. 2(a) and FIG. 2(b) were matched, when the main signal level is equal to the ambiguity. Using modulation, the ambiguity that exists in FIG. 2(c) has disappeared in FIG. 2(d). In a simulation study using Pi-SAR-L2, JAXA indicates that ALOS-2 will achieve an improvement of ambiguity ratios in range and azimuth by adopting alternate up-down chirping with periodic π -shift in the transmission code.

[0053] An embodiment exploits the ability of a digital beamformer to form multiple simultaneous beams from a same radar dataset (sampled amplitudes and phases) derived from the receive channels of the SAR. The digital beamformer has the ability to form a plurality of beams that may be specifically pointed at the sources of the dominant ambiguities. In this manner, the ambiguity signals can be measured directly with the highest possible signal to noise ratio. After correcting for deterministic amplitude and phase variations within and between the antenna beams, the measured ambiguities may be digitally removed from the main imaging beam signal.

5 [0054] Electromagnetic waves and the signal derived from the waves are spatially and temporally varying complex vectors. When the signals are added at the feed of an antenna, or within the beamformer of a phased array, the signals are treated as vectors, whether the beamformer is a passive summing device with phase shifters, or a post ADC weighted complex matrix summation with complex weights. When these signals propagate to the antenna from a plurality of scattering areas (point or distributed), the signals add as complex amplitude vectors at the antenna.

15 [0055] The inventors have recognized that the signals received by the beams pointed substantially away (in the case of the imaging beam), or substantially towards (as in the case of a deliberately introduced digitally beamformed beam designed for the purpose of interrogating the ambiguity) the sources of the ambiguities are the same except for an amplitude and phase term. These amplitude and phase terms may be introduced by the fact that the antenna is forming a multiplicity of beams or by amplitude and phase errors in the receive paths.

25 [0056] There is no need to deliberately introduce a phase offset from pulse-to-pulse. The pulse envelope and phase are determined by the antenna, as are the errors associated with them. However, there is thermal noise. This noise gives rise to noise equivalent sigma zero (NESZ) values, which are statistically independent between the digitally formed beams when they are steered relative to each other such that the beams are orthogonal, for example, when the nulls of

one beam angularly correspond to the peaks of the other beam. Some statistical correlation occurs when the beams are steered very close to each other, as discussed in more detail below.

5 [0057] In a small radar, small apertures require higher PRFs and range ambiguities may become too large, even at intermediate incidence angles. In certain extreme cases the range ambiguities may rise up on the antenna main lobe, as shown in FIG. 4.

10 [0058] An embodiment uses multiple receive beams in elevation. A plurality of beams may be formed from the digital data collected from the phased array elements in elevation. One beam (e.g., the main beam) is used for imaging the swath of interest. The other beams are directed at the dominant range ambiguities (in FIGS. 6A, 6B, 7A and 7B, discussed in more detail below, these are the +1 and -1 ambiguities).

15 [0059] The main beam produces a signal that is the sum of the swath of interest and the range ambiguous returns. Having measured the range ambiguous returns directly using the other digitally formed beams, the majority of the ambiguous signal may be removed from the main beam.

20 [0060] FIGS. 5A and 5B illustrate an embodiment of two-way beam patterns and the ambiguous two-way beam patterns (transmit and receive). The +1 elevation beam is steered specifically to measure the +1 range ambiguity. Similarly, the -1 elevation beam is steered specifically to measure the -1 range ambiguity.

25 [0061] As illustrated in FIGS. 5A and 5B, the worst case range ambiguity on the main imaging beam is approximately at -10dB. This corresponds to the first range sample. The +1 elevation beam is pointed substantially towards the +1 ambiguity and thus, measures a larger “ambiguous signal.”

[0062] The signal in the main beam and the signal in the +1 elevation beam are the same in all respects other than the amplitude and phases that are deterministically introduced by the beamforming system.

30 [0063] To remove the first ambiguity from the main beam, for each range sample, the determined ratio of the complex sensitivity of the main beam to the

complex sensitivity to the +1 elevation beam is employed. Inverting that complex determined ratio provides a factor that, when multiplied by the ambiguous signal (as measured in the +1 elevation beam), produces a signal that closely represents the ambiguous signal as measured in the main beam. In this manner, one of the ambiguous components present in the main beam signal may be estimated.

5 [0064] Continuing with this example (limited to just the main beam and the +1 elevation beam), a complex vector of the same length as the number of range samples is formed. The elements of this complex vector are the determined ratio of the complex sensitivity of the main beam to the complex sensitivity to the +1 elevation beam. Inverting this, element by element, produces a complex vector that, when multiplied by the range sampled +1 ambiguity produces a signal that closely represents the entire range sampled +1 ambiguity present in the main beam.

10 [0065] This complex vector that is used to estimate the ambiguous signal in the main beam is of a deterministic shape governed by the transmit and receive patterns of the main beam in the area of the ambiguous scatterer, and the transmit and receive patterns of the +1 ambiguity interrogation beam in the area of the same ambiguous scatterer. If the antenna patterns are perfectly calibrated, then the +1 ambiguity scaled by this complex vector provides us with the components of the main beam range samples that result from that +1 ambiguity.

15 [0066] The same process may be applied to the -1 ambiguity in the example depicted in FIGS. 5A and 5B. This reasoning may be extrapolated to any number of ambiguities.

20 [0067] In the event that any pattern has a calibration error, the technique will result in a similar error in the estimation and removal of the ambiguous signal component within the main beam. Thus, this would result in a sub-optimal cancelation of the ambiguity from the main beam signal.

25 [0068] Correlation techniques may be applied to estimate any potential calibration error. The estimated calibration error may be employed to optimize the removal of the ambiguous signal in the presence of such calibration errors.

It is typical that the largest ambiguities are located on the sides of the main lobe as discussed earlier. This is the easiest part of the beam to calibrate accurately.

[0069] In the process of measuring the +1 ambiguity with the +1 beam, an ambiguity from the main beam scatterer position is also acquired. This, say “-1 ambiguity” (as it falls immediately to the left of the interrogation beam peak) may be reduced in a two-fold process. Firstly, this “-1 ambiguity” is not on the peak of the +1 interrogation beam and is thus, a number of dBs down. Secondly, this “-1 ambiguity” may be reduced during the scaling using the deterministic vector derived from the ratio of beam patterns. The net result is that this ambiguity is significantly reduced.

[0070] This process may be extended to multiple ambiguities and multiple beams.

[0071] In terms of noise, the noise floor in the +1 beam is also added to the main beam, but has little impact since it is reduced by the same scaling vector. For example, if the worst-case ambiguity was at -6dB on the main lobe of the main beam and at 0dB on the +1 interrogation beam, then the entire signal (including noise) may be reduced by 6dB prior to correction. The net result is adding to an existing noise floor an additional noise component, which in this worst-case scenario, is 6dB lower. There are two extreme cases to be dealt with. In the one case, when the ambiguities are very close to the boresight of the main beam, these two noise components will be somewhat correlated and add linearly,

$$10 \log_{10}(\sqrt{1} + \sqrt{0.25})^2 = 3.5 \text{ dB}$$

[0072] In the other extreme, the interrogation beam of the +1 ambiguity may be far enough away that there is very little correlation between these two noise components and they are added as powers,

$$10 \log_{10}(1 + 0.25) = 1 \text{ dB}$$

[0073] If the NESZ on the main beam signal is α dB, then the NESZ resulting from the proposed method is at worst $\alpha + 3.5$ dB.

[0074] At a single range sample, the signal received from the main beam directed at the desired target is

$$\begin{aligned}
S_0 = & \frac{\sigma_0(\beta_0)D_{TX}(\theta_0 + \varepsilon_0)D_{RX_0}(\theta_0 + \varepsilon_0)}{R_0^3 \sin(\beta_0)} \\
& + \frac{\sigma_0(\beta_1)D_{TX}(\theta_1 + \varepsilon_0)D_{RX_0}(\theta_1 + \varepsilon_0)}{R_1^3 \sin(\beta_1)} \\
& + \frac{\sigma_0(\beta_{-1})D_{TX}(\theta_{-1} + \varepsilon_0)D_{RX_0}(\theta_{-1} + \varepsilon_0)}{R_{-1}^3 \sin(\beta_{-1})} \\
& + \frac{\sigma_0(\beta_2)D_{TX}(\theta_2 + \varepsilon_0)D_{RX_0}(\theta_2 + \varepsilon_0)}{R_2^3 \sin(\beta_2)} \\
& + \frac{\sigma_0(\beta_{-2})D_{TX}(\theta_{-2} + \varepsilon_0)D_{RX_0}(\theta_{-2} + \varepsilon_0)}{R_{-2}^3 \sin(\beta_{-2})} + \dots
\end{aligned}$$

(Eq. 1)

[0075] The first term in Eq. 2 represents the main beam response of the unambiguous signal, and the remaining terms represent the ambiguous signals from the +1 and -1 ambiguities and the +2 and -2 ambiguities. Equation 2 is extended to include the higher order ambiguities. R_0 is the slant range to the unambiguous target. R_1 and R_{-1} are the ranges to the ambiguous targets are defined as

$$R_1 = R_0 + \frac{c}{2f_p}$$

(Eq. 3)

10 and

$$R_{-1} = R_0 - \frac{c}{2f_p}$$

(Eq. 4)

where β_i is the incidence angle of the i^{th} range ambiguity, ε_n is the error in the n^{th} receive beam pointing, and θ_i is the angle off boresight.

15 [0076] Similarly, for the same range sample, the received signal from the receive beam directed at the +1 ambiguity is given by

$$\begin{aligned}
S_1 = & \frac{\sigma_0(\beta_1)D_{TX}(\theta_1 + \varepsilon_0)D_{RX_1}(\theta_1 + \varepsilon_1)}{R_1^3 \sin(\beta_1)} \\
& + \frac{\sigma_0(\beta_2)D_{TX}(\theta_2 + \varepsilon_0)D_{RX_1}(\theta_2 + \varepsilon_1)}{R_2^3 \sin(\beta_2)} \\
& + \frac{\sigma_0(\beta_0)D_{TX}(\theta_0 + \varepsilon_0)D_{RX_1}(\theta_0 + \varepsilon_1)}{R_0^3 \sin(\beta_0)}
\end{aligned}$$

$$\begin{aligned}
& + \frac{\sigma_0(\beta_{-1})D_{TX}(\theta_{-1} + \varepsilon_0)D_{RX_1}(\theta_{-1} + \varepsilon_1)}{R_{-1}^3 \sin(\beta_{-1})} \\
& + \frac{\sigma_0(\beta_{-2})D_{TX}(\theta_{-2} + \varepsilon_0)D_{RX_1}(\theta_{-2} + \varepsilon_1)}{R_{-2}^3 \sin(\beta_{-2})} + \dots
\end{aligned}$$

(Eq. 2)

[0077] After scaling and addition, the first term in S_1 approximately cancels the +1 ambiguity in the image, the second term adds a smaller ambiguity, and the third term adds a radiometric error of order:

5

$$\frac{D_{RX_0}(\theta_0 + \varepsilon_0)}{D_{RX_1}(\theta_0 + \varepsilon_0)}$$

[0078] It follows that for the same range sample, the signal received from the beam directed at the -1 ambiguity is

$$\begin{aligned}
S_{-1} = & \frac{\sigma_0(\beta_{-1})D_{TX}(\theta_{-1} + \varepsilon_0)D_{RX_{-1}}(\theta_{-1} + \varepsilon_{-1})}{R_{-1}^3 \sin(\beta_{-1})} \\
& + \frac{\sigma_0(\beta_{-2})D_{TX}(\theta_{-2} + \varepsilon_0)D_{RX_{-1}}(\theta_{-2} + \varepsilon_{-1})}{R_{-2}^3 \sin(\beta_{-2})} \\
& + \frac{\sigma_0(\beta_0)D_{TX}(\theta_0 + \varepsilon_0)D_{RX_{-1}}(\theta_0 + \varepsilon_{-1})}{R_0^3 \sin(\beta_0)} \\
& + \frac{\sigma_0(\beta_1)D_{TX}(\theta_1 + \varepsilon_0)D_{RX_{-1}}(\theta_1 + \varepsilon_{-1})}{R_1^3 \sin(\beta_1)} \\
& + \frac{\sigma_0(\beta_2)D_{TX}(\theta_2 + \varepsilon_0)D_{RX_{-1}}(\theta_2 + \varepsilon_{-1})}{R_2^3 \sin(\beta_2)} + \dots
\end{aligned}$$

10

(Eq. 3)

[0079] The corrected signal is then

$$\begin{aligned}
S_{0_{corr}} & = S_0 - \frac{D_{RX_0}(\theta_1 + \varepsilon_0)}{D_{RX_1}(\theta_1 + \varepsilon_1)} S_1 - \frac{D_{RX_0}(\theta_{-1} + \varepsilon_0)}{D_{RX_{-1}}(\theta_{-1} + \varepsilon_{-1})} S_{-1} \\
& + (\text{higher order ambiguities from } D_{TX}D_{RX_n} \text{ and } D_{TX}D_{RX_0}) \\
& + (\text{radiometric errors arising from 3rd term of } S_1 \text{ and } S_2)
\end{aligned}$$

(Eq. 4)

[0080] In this formulation D_{TX} is the transmit beam pattern and is the same for all beams, and D_{RX_n} is the receive beam pattern, which has a peak at θ_n for a given beam n .

15

[0081] Equations 5, 6, and 7 can also be cast into a linear system of the form

$$\vec{S} = \mathbf{M} \cdot \vec{S}^c + \vec{Res}$$

(Eq. 5)

where:

- 5 • \vec{S}^c is the vector of $[S_0, S_{-1}, S_1, \dots]^T$ (with the number of elements equal to the number of beams received)
- \vec{S} is the vector of the desired ambiguity free signals $[S_0^c, S_{-1}^c, S_1^c, \dots]^T$ etc.
- \mathbf{M} is the square matrix formed from the proper ratios of the beam patterns at the contributing angles, as found in equations 2, 5, and 6
- 10 • \vec{Res} are the residual contributions from equations 2, 5, and 6 not accounted for by $\mathbf{M} \cdot \vec{S}^c$

[0082] Assuming $\vec{Res} = 0$, then solving this system for \vec{S}^c will provide an estimate of the signals without the interrogated ambiguities, of which S_0^c is the desired solution. This approach allows for removing the effect on the non-ambiguous signal in the interrogation beams, further increasing the effectiveness of this approach. FIGS. 6A and 6B show the effect of this approach in reducing ambiguities at a look angle of 40 degrees. The worst uncorrected range ambiguity to signal ratio is nearly -5dB. After correction, shown as Cor RASR, the range ambiguity to signal ratio drops to -17db in the worst case with most of the range being substantially better. FIGS. 7A and 7B show the detail of the effect of this approach. Note that this approach is also insensitive to practical spacecraft roll errors, since the matrix is formed from beam ratios.

[0083] Note that the formulation above is on a range sample by range sample basis, and the determined vector that is used in the formulation of the matrix \mathbf{M} may be stored on board. Thus, an embodiment of this matrix inversion technique may be carried out in real-time on board before or after range pulse compression. Therefore, only a single downlink data stream may be employed if on-board processing is selected.

30 [0084] FIG. 8 is a block diagram of a SAR system 800, in accordance with the systems and methods of the present application. SAR system 800 can be a

multi-band SAR system, for example a dual-band XL SAR system. SAR system 800 can be on-board a SAR platform such as an aircraft, unmanned aircraft, drone, satellite, space station, or spacecraft. SAR system 800 comprises a SAR antenna 802, a SAR transceiver 804, a SAR controller 806, a SAR processor 808, and a communications antenna 810. Other SAR systems may be employed, such as a single band SAR.

[0085] SAR antenna 802 can be a shared aperture antenna. SAR antenna 802 can be a planar phased array such as described in International Patent Application Publication WO 2017/044168 entitled “EFFICIENT PLANAR PHASED ARRAY ANTENNA ASSEMBLY”, for example. SAR antenna 802 is communicatively coupled to transceiver 804. SAR transceiver 804 can transmit and receive pulses at one or more frequency bands, for example at X-band and L-band. SAR transceiver 804 can transmit and receive pulses for two or more frequency bands at the same time. For example, SAR transceiver 804 can transmit and receive L-band pulses for wide-swath SAR imaging and X-band pulses for high-resolution imaging at the same time (*e.g.*, in the same acquisition window). The pulses can be synchronized with each other. The SAR antenna can transmit and receive pulses for one or more imaging modes such as ScanSAR mode and strip-map mode. SAR transceiver 804 can transmit and receive pulses in one or more beams, and in one or more sub-beams. In some implementations, SAR transceiver 804 includes one or more transmit/receive modules (also referred to in the present application as TR modules). In some implementations, SAR transceiver 804 includes a transmitter and a separate receiver. In some embodiments, the SAR transceiver 804, in operation, digitally creates a plurality of beams simultaneously. The beams are used to interrogate a desired swath, as well as areas of dominant ambiguous signals.

[0086] SAR controller 806 can comprise one or more processors. SAR controller 806 can include at least one of a Field-Programmable Gate Array (FPGA), an Application Specific Integrated Circuit (ASIC), a microcontroller,

and a microprocessor, and one or more programs or firmware stored on one or more nontransitory computer- or processor-readable media.

[0087] SAR processor 808 can process SAR data acquired by SAR antenna 802 and SAR transceiver 804. SAR processor 808 can process data in near-real-time. SAR processor 808 can perform range compression, azimuth compression, target detection and identification, chip extraction, velocity estimation, and/or image classification. SAR processor 808 can process data for one or more imaging modes of SAR system 800. In one implementation, SAR processor 808 can process wide-swath ScanSAR mode and high-resolution strip-map mode data. In one implementation, SAR processor 808 can process strip-map mode data and Spotlight mode data. In one implementation, SAR processor 808 can process at least two of wide-swath ScanSAR mode, strip-map mode, high-resolution strip-map mode, and Spotlight mode data.

[0088] Communications antenna 810 can transmit and receive data, for example communications antenna 810 can transmit acquired SAR data, processed SAR targets, target detections, identifications, and image classifications from SAR system 800 to a ground terminal. Communications antenna 810 can receive commands and/or ancillary data from a ground terminal. The ground terminal (not shown in FIG. 8) can include a communications antenna and a transceiver.

[0089] Embodiments of an SAR system may include fewer components than illustrated, may include more components that illustrated, may combine illustrated components, may separate illustrated components into separate components, and various combinations thereof. For example, the SAR controller 806 and the SAR processor 808 may be combined into a single processor in some embodiments.

[0090] SAR antenna 802 of FIG. 8 can be, for example, a planar phased array antenna. FIG. 9 shows an example efficient planar phased array antenna assembly 900. The size of antenna assembly 900 can be tailored to meet the gain and bandwidth requirements of a particular application. An example application is a dual-band, dual-polarization SAR antenna. In an example implementation of a dual-band, dual-polarization SAR antenna, assembly 900 is

approximately 2.15m wide, 1.55m long and 50mm deep, and weighs approximately 30kg. In another implementation, SAR antenna 902 comprises a single panel of dimensions 6 m by 2 m. In yet another implementation, SAR antenna 902 comprises six panels, each panel of dimensions 1 m by 2 m.

5 [0091] Example antenna assembly 900 of FIG. 9 is a dual-band (X-band and L-band), dual-polarization (H and V polarizations at L-band) SAR antenna assembly. While embodiments described in this document relate to dual X-band and L-band SAR antennas, and the technology is particularly suitable for space-based SAR antennas for reasons described elsewhere in this document, a similar
10 approach can also be adopted for other frequencies, polarizations, configurations, and applications including, but not limited to, single-band and multi-band SAR antennas at different frequencies, and microwave and mm-wave communication antennas.

[0092] Antenna assembly 900 comprises a first face sheet 902 on a top surface
15 of antenna assembly 900, containing slots for the L-band and X-band radiating elements. Antenna assembly 900 comprises microwave structure 904 below first face sheet 902. Microwave structure 904 comprises one or more subarrays such as subarray 904-1, each subarray comprising L-band and X-band radiating elements.

20 [0093] Microwave structure 904 can be a metal structure that is self-supporting without a separate structural subassembly. Microwave structure 904 can be machined or fabricated from one or more metal blocks, such as aluminium blocks or blocks of another suitable conductive material. The choice of material for microwave structure 904 determines, at least in part, the losses and therefore
25 the efficiency of the antenna.

[0094] Antenna assembly 902 comprises second face sheet 906 below
microwave structure 904, second face sheet 906 closing one or more L-band cavities at the back. Second face sheet 906 comprises one or more sub-array face sheets such as 906-1.

30 [0095] Antenna assembly 900 comprises third face sheet 908 below second face sheet 906, third face sheet 908 comprising waveguide terminations. Third face

sheet 908 also provides at least partial structural support for antenna assembly 900.

[0096] In some implementations, antenna assembly 900 comprises a multi-layer printed circuit board (PCB) (not shown in FIG. 9) below third face sheet 908, the PCB housing a corporate feed network for the X-band and L-band radiating elements. Other antenna assemblies may be employed, such as other SAR assemblies, multi-aperture SAR assemblies, TOPSAR, ScanSAR, multi-beam ScanSAR, staggered PRF, SCORE, and used in various operational modes in various embodiments.

10 [0097] FIG. 10 is a flow chart illustrating one example process 1000 of generating an image using an SAR system. The process 1000 may be performed, for example, by the SAR system 800 of FIG. 8.

[0098] At 1002, the process 1000 generates or sets up matrices used to create beams of the SAR system, including a main or first beam of the SAR system to illuminate a swath for which an image is desired, and one or more beams to illuminate range ambiguities. Conventionally, matrices are generated so as to avoid range ambiguities. Locating range ambiguities and generating matrices to direct a beam at a desired location are known, and may be done based, for example, on backscatter signals received from the ground. As opposed to conventional beam forming to direct beams away from range ambiguities, matrices are generated which direct the beams at range ambiguities, including ambiguities which may be on the main lobe of the backscatter energy. The process 1000 proceeds from 1002 to 1004.

25 [0099] At 1004, the process 1000 transmits a pulse via the first beam. The process 1000 proceeds from 1004 to 1008.

[00100] At 1008, the process 1000 receives backscatter energy simultaneously from the main beam. The process 1000 proceeds from 1008 to 1010.

[00101] At 1010, the process 1000 processes the backscatter energy using the matrices set up at 1002, generating a first signal associated with the first beam directed at the swath, and one or more second signals associated respective

30

beams of the one or more beams directed to the range ambiguities. The process 1000 proceeds from 1010 to 1012.

[00102] At 1012, the process 1000 generates ambiguity signals. This may be done by, for example, combining the second signals with respective determined complex vectors, which are based on ratios of the complex sensitivity of the first beam to the complex sensitivity of the respective second beam, generating one or more ambiguity signals. The process 1000 proceeds from 1012 to 1014.

[00103] At 1014, the process generates an image signal associated with the swath. This may be done, for example, by combining the first signal with one or more of the ambiguity signals, at least partially cancelling ambiguities in the first signal. The process 1000 proceeds from 1014 to 1016.

[00104] At 1016, the process 1000 outputs the image signal. The process proceeds from 1016 to 1018.

[00105] At 1018, the process 1000 determines whether to image another swath, for example, based on control signals received via a communication antenna. When it is determined at 1018 to image another swath, the process 1000 proceeds from 1018 to 1002. When it is not determined at 1018 to image another swath, the process proceeds from 1018 to 1020, where the process 1000 may terminate or perform other processing on the image or image data.

[00106] Embodiments of the process 1000 of FIG. 10 may include more acts than illustrated, may include fewer acts than illustrated, may separate illustrated acts into multiple acts, may combine illustrated acts into fewer acts, and may perform illustrated acts in various orders, which may include performing illustrated acts in parallel or using an iterative process. For example, in an embodiment of the process 1000, compensation for an estimated calibration error may be applied. In another example, data may be transmitted after act 1010 to a remote (e.g., ground-based) server for performing acts 1012, 1014 and 1016 at the remote server.

[00107] One or more embodiments may provide one or more of the following advantages as compared to conventional approaches: range ambiguities may be efficiently suppressed in SmallSat digital beamforming SARS operating in a

single imaging beam mode, in which range ambiguities are usually on the main lobe of the main beam; directing interrogation beams at the range ambiguities facilitates generating highly accurate estimates of the dominant range ambiguities; measuring range ambiguities using the same pulse employed to
5 image the swath facilitates the range ambiguity signal and the main beam signal being very similar, which facilitates simplifying the processing and thus facilitates using on-board real-time processing of the image data; the beams may be closer together, which may facilitate reducing the effects from range cell migration, topography, curved Earth and non-separable beam patterns; and
10 range ambiguities being located on the main lobe of the beam may simplify weighting vector calculations and provide more stability in the presence of thermoelastic distortion.

[00108] The various embodiments described above can be combined to provide further embodiments. Aspects of the embodiments can be modified, if
15 necessary, to employ systems, circuits and concepts of the various patents, applications and publications to provide yet further embodiments. The teachings of U.S. provisional patent application Serial No. 62/590,153 are incorporated herein by reference in their entirety.

[00109] The foregoing detailed description has set forth various embodiments of
20 the devices and/or processes via the use of block diagrams, schematics, and examples. Insofar as such block diagrams, schematics, and examples contain one or more functions and/or operations, it will be understood by those skilled in the art that each function and/or operation within such block diagrams, flowcharts, or examples can be implemented, individually and/or collectively,
25 by a wide range of hardware, software, firmware, or virtually any combination thereof. In one embodiment, the present subject matter may be implemented via Application Specific Integrated Circuits (ASICs). However, those skilled in the art will recognize that the embodiments disclosed herein, in whole or in part, can be equivalently implemented in standard integrated circuits, as one or more
30 computer programs running on one or more computers (*e.g.*, as one or more programs running on one or more computer systems), as one or more programs

running on one or more controllers (*e.g.*, microcontrollers) as one or more programs running on one or more processors (*e.g.*, microprocessors), as firmware, or as virtually any combination thereof, and that designing the circuitry and/or writing the code for the software and or firmware would be well
5 within the skill of one of ordinary skill in the art in light of this disclosure.

[00110] While particular elements, embodiments and applications of the present technology have been shown and described, it will be understood, that the technology is not limited thereto since modifications can be made by those skilled in the art without departing from the scope of the present disclosure,
10 particularly in light of the foregoing teachings.

[00111] In general, in the following claims, the terms used should not be construed to limit the claims to the specific embodiments disclosed in the specification and the claims, but should be construed to include all possible embodiments along with the full scope of equivalents to which such claims are
15 entitled. Accordingly, the claims are not limited by the disclosure.

CLAIMS

What is claimed is:

1. A method of operation of a synthetic aperture radar (SAR) system comprising at least one SAR antenna, at least one SAR processor and at least one SAR transceiver, the method comprising:
 - defining a first beam to illuminate a first swath using the at least one SAR antenna;
 - defining a second beam to illuminate a first area of ambiguity associated with the first beam;
 - transmitting a pulse via the first beam and receiving backscatter energy;
 - generating, by the at least one SAR processor based on the received backscatter energy, a first signal associated with the first beam and a second signal associated with the second beam;
 - combining the second signal with a first determined complex vector, generating a first ambiguity signal; and
 - combining the first signal with the first ambiguity signal, generating an image signal associated with the first swath.

2. The method of claim 1, comprising
 - defining a third beam to illuminate a second area of ambiguity associated with the first beam;
 - generating, by the at least one SAR processor based on the received backscatter energy, a third signal associated with the third beam;
 - combining the third signal with a second determined complex vector, generating a second ambiguity signal;
 - combining the first signal with the first ambiguity signal and the second ambiguity signal, generating the image signal associated with the first swath.

3. A method of operation of a synthetic aperture radar (SAR) system comprising at least one SAR antenna, at least one SAR processor and at least one SAR transceiver, the method comprising:
 - defining a first beam to illuminate a first swath using the at least one SAR antenna;
 - defining a plurality of second beams to illuminate respective areas of ambiguity associated with the first beam;
 - transmitting a pulse via the first beam and receiving backscatter energy;
 - generating, by the at least one SAR processor and based on the backscatter energy, a first signal associated with the first beam and a plurality of second signals associated with respective beams of the plurality of second beams;
 - combining the signals of the plurality of second signals with respective determined complex vectors, generating a plurality of ambiguity signals; and
 - combining the first signal with the plurality of ambiguity signals, generating an image signal associated with the first swath.
4. The method of any of the preceding claims wherein a determined complex vector represents a ratio of a complex sensitivity of the first beam to a complex sensitivity of a beam illuminating an area of ambiguity associated with the first beam.
5. The method of any of the preceding claims wherein the beams are multiple simultaneous elevation beams.
6. The method of any of the preceding claims wherein the beams are formed from an aperture.
7. The method of any of the preceding claims, comprising:
 - operating the SAR in a Quad-Pol, single imaging beam mode.

8. The method of any of the preceding claims wherein directing a beam to illuminate an area of ambiguity associated with the first beam comprises directing the beam based on one or more of:
 - a beam center offset; or
 - beam pattern shaping.
9. The method of any of the preceding claims, comprising directing beams at non-sequential areas of ambiguity associated with the first beam.
10. The method of any of the preceding claims wherein the combining the first signal with an ambiguity signal at least partially cancels ambiguous energy present in the first signal.
11. The method of any of the preceding claims wherein the combining the first signal with an ambiguity signal comprises applying linear algebra.
12. The method of any of the preceding claims wherein the combining the first signal with an ambiguity signal comprises subtracting the ambiguity signal from the first signal.
13. The method of any of the preceding claims wherein the SAR comprises multiple overlapping or non-overlapping azimuth apertures and the method comprises using azimuth modulation.
14. The method of any of the preceding claims, comprising using alternating up/down chirp modulation.
15. The method of any of the preceding claims, comprising using a multi-polarization mode with 5 beams receiving backscatter energy at each polarization.

16. The method of any of the preceding claims wherein the SAR operates in an L-band.

17. The method of any of the preceding claims, comprising estimating a calibration error associated with a ratio of complex sensitive and compensating for the calibration error.

18. The method of any of the preceding claims wherein the ambiguity is a range ambiguity located on a main lobe of the first beam.

19. The method of any of the preceding claims wherein the range ambiguities are measured on backscatter of the pulse transmitted on the first beam.

20. A synthetic aperture radar (SAR) system comprising at least one SAR antenna, at least one SAR processor and at least one SAR transceiver, the SAR system operable to perform the method of any of claims 1 to 19.

21. The SAR system of claim 20 wherein the at least one SAR antenna, the at least one SAR processor and the at least one SAR transceiver are co-located on a spaceborne or airborne SAR platform.

22. The SAR system of claim 21 wherein the spaceborne SAR platform is a free-flying spacecraft.

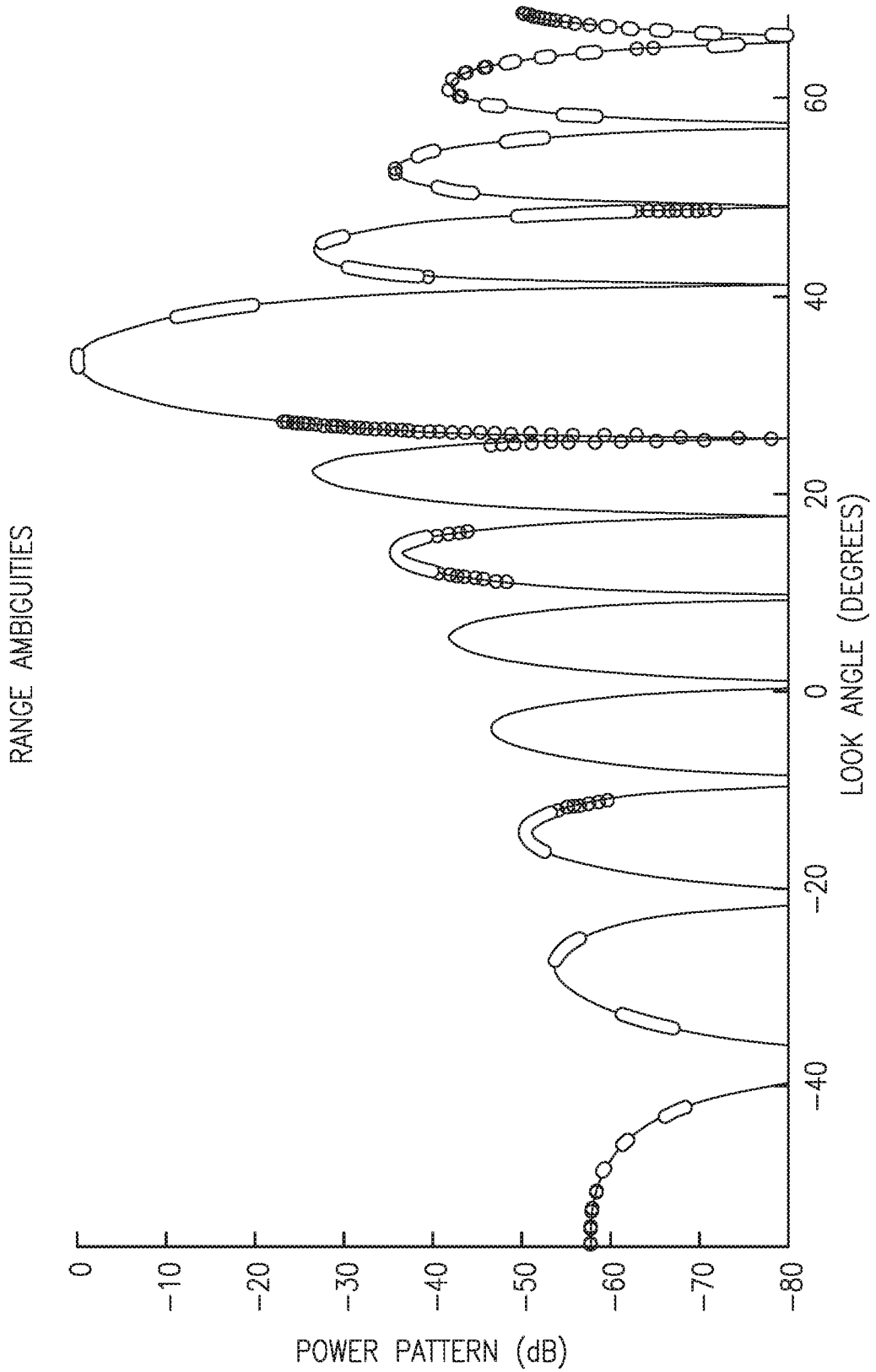

FIG. 1

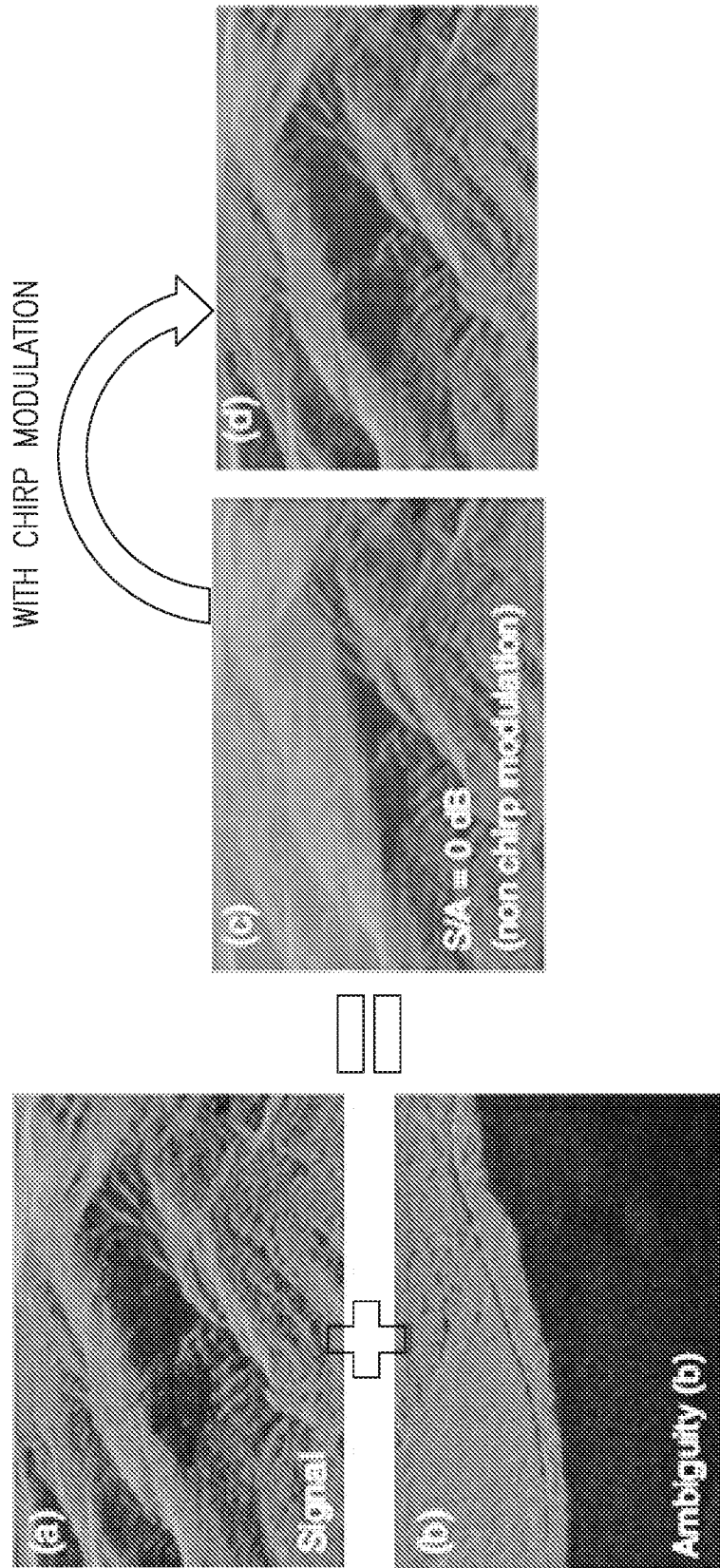

FIG. 2A-2D

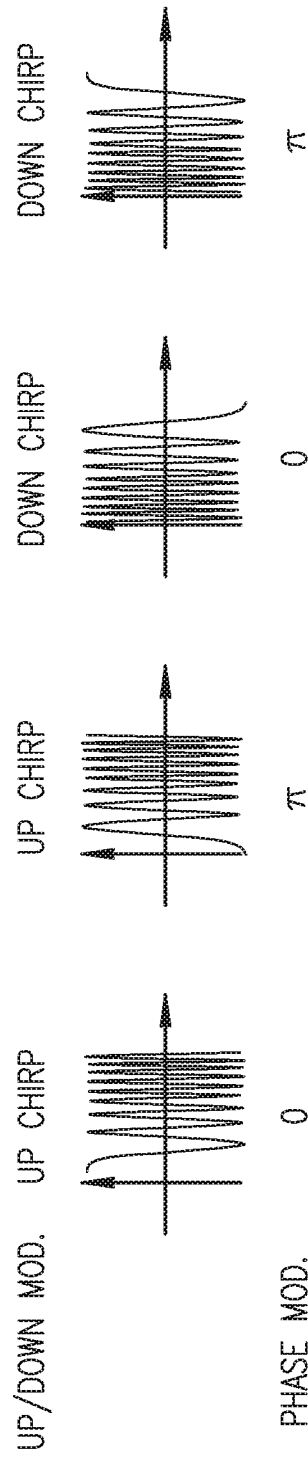

FIG. 3

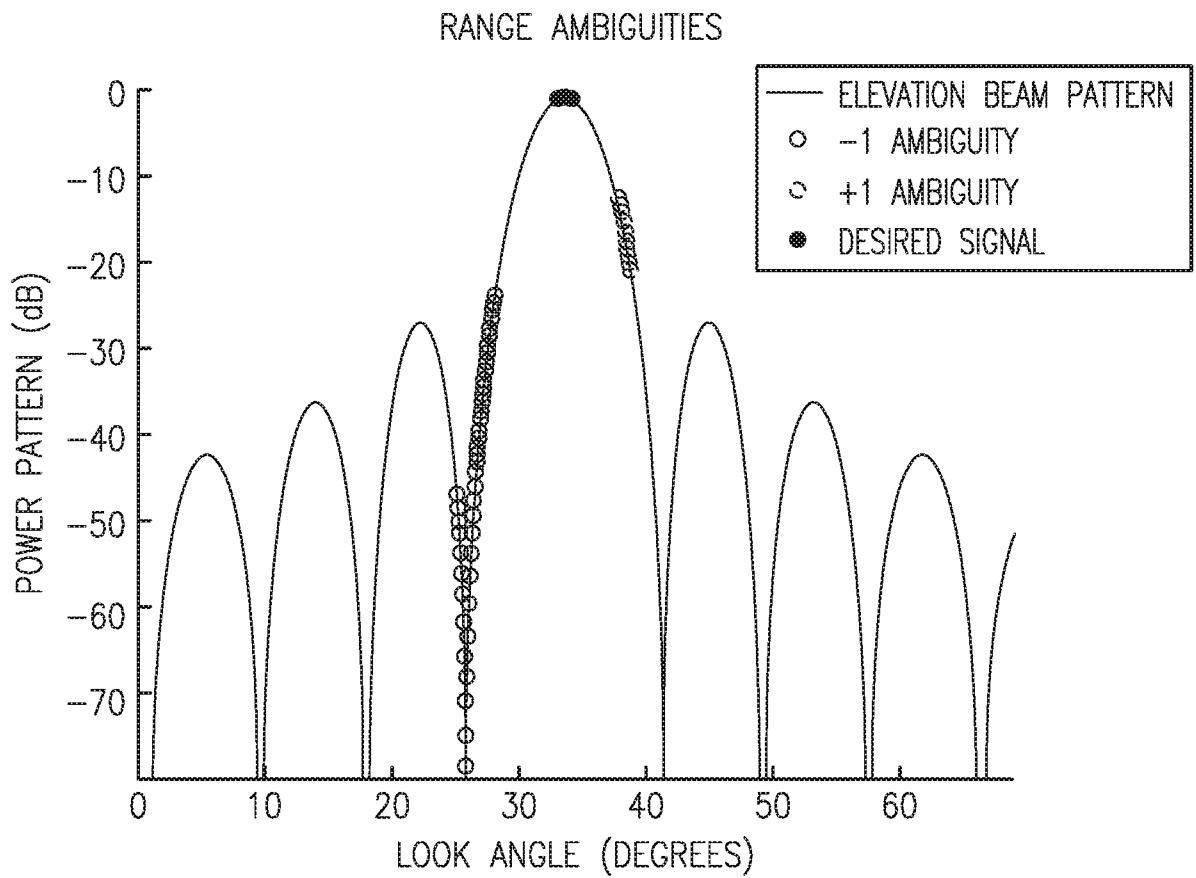

FIG. 4

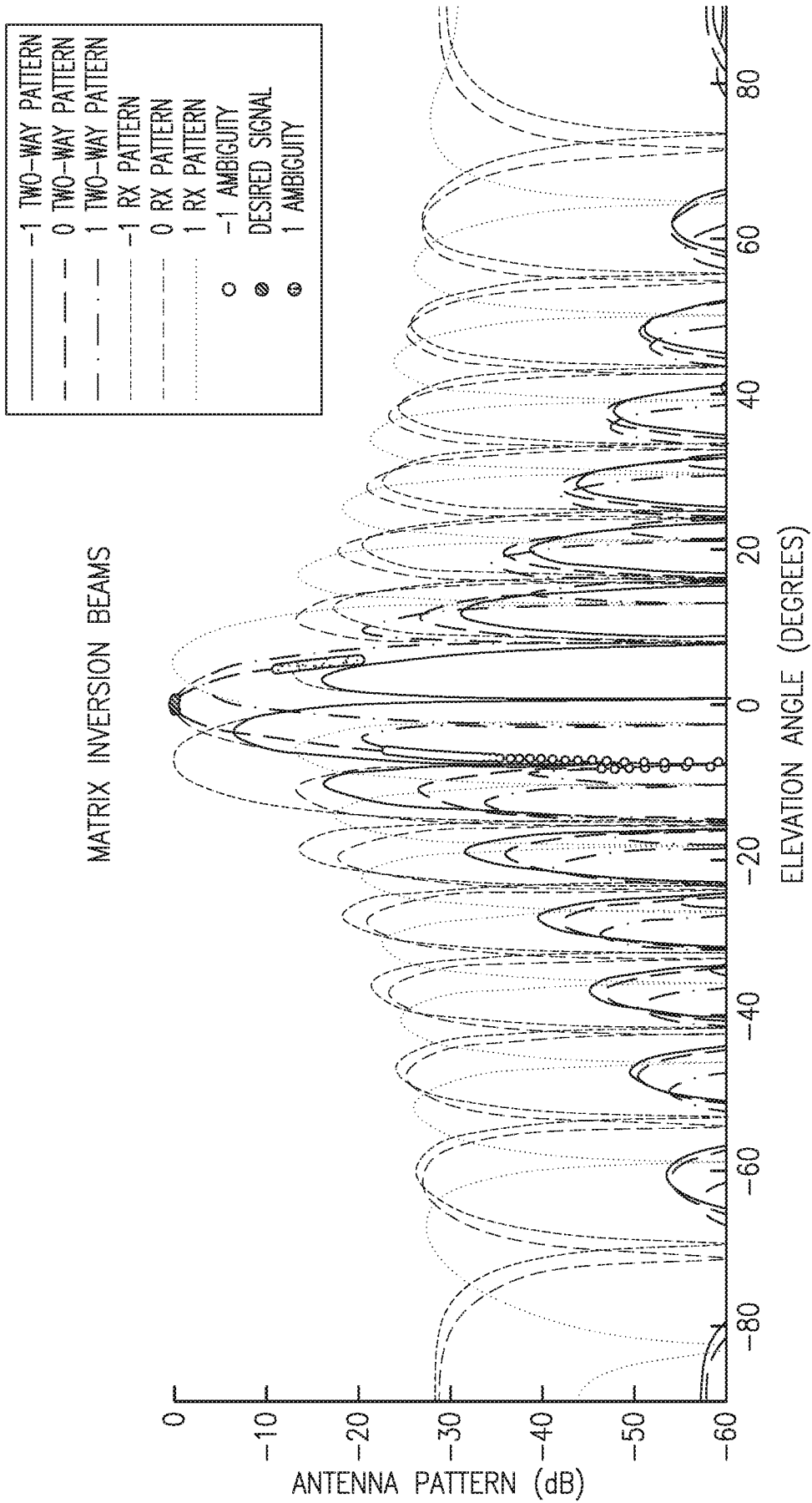

FIG. 5A

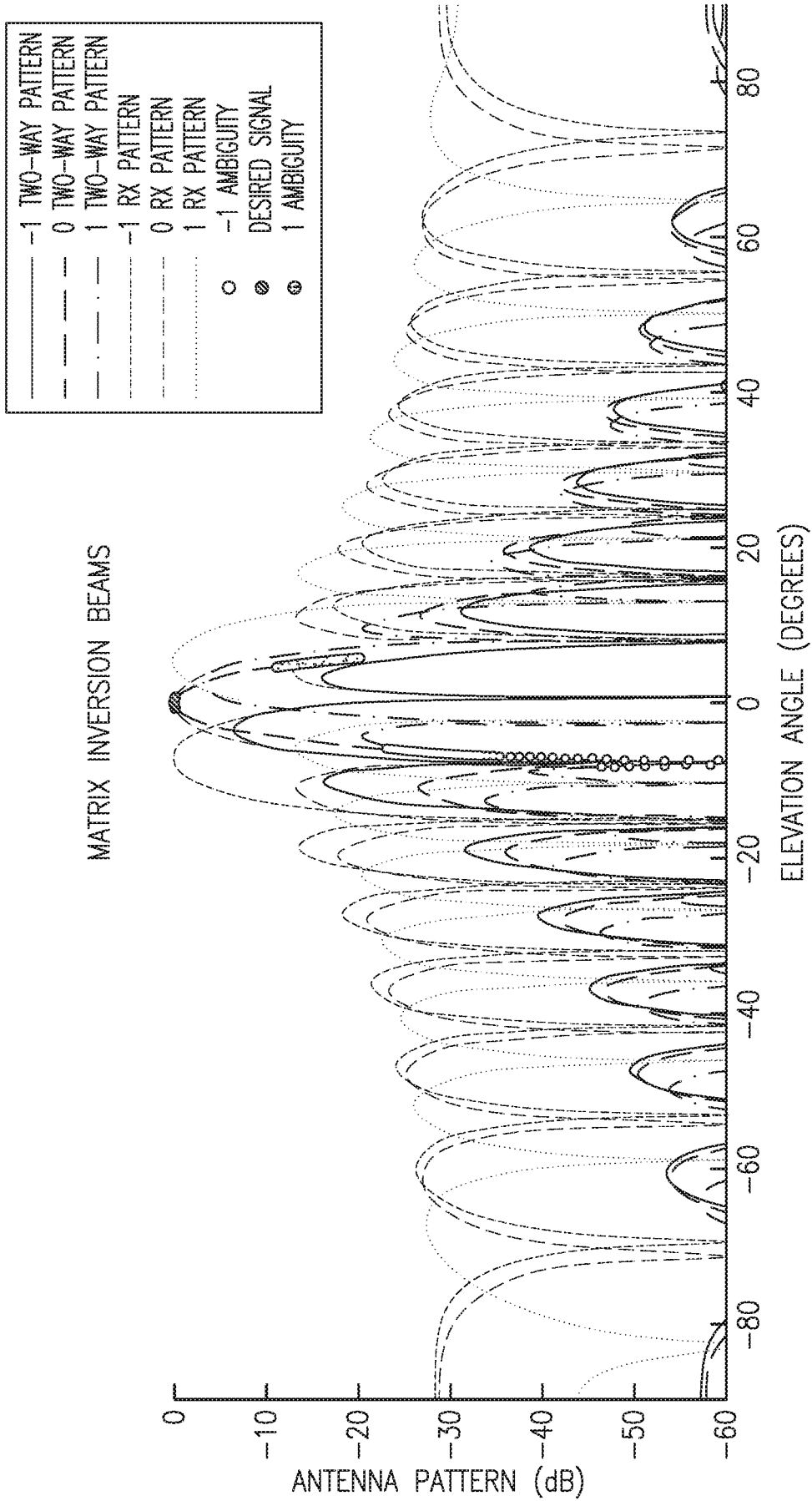

FIG. 5B

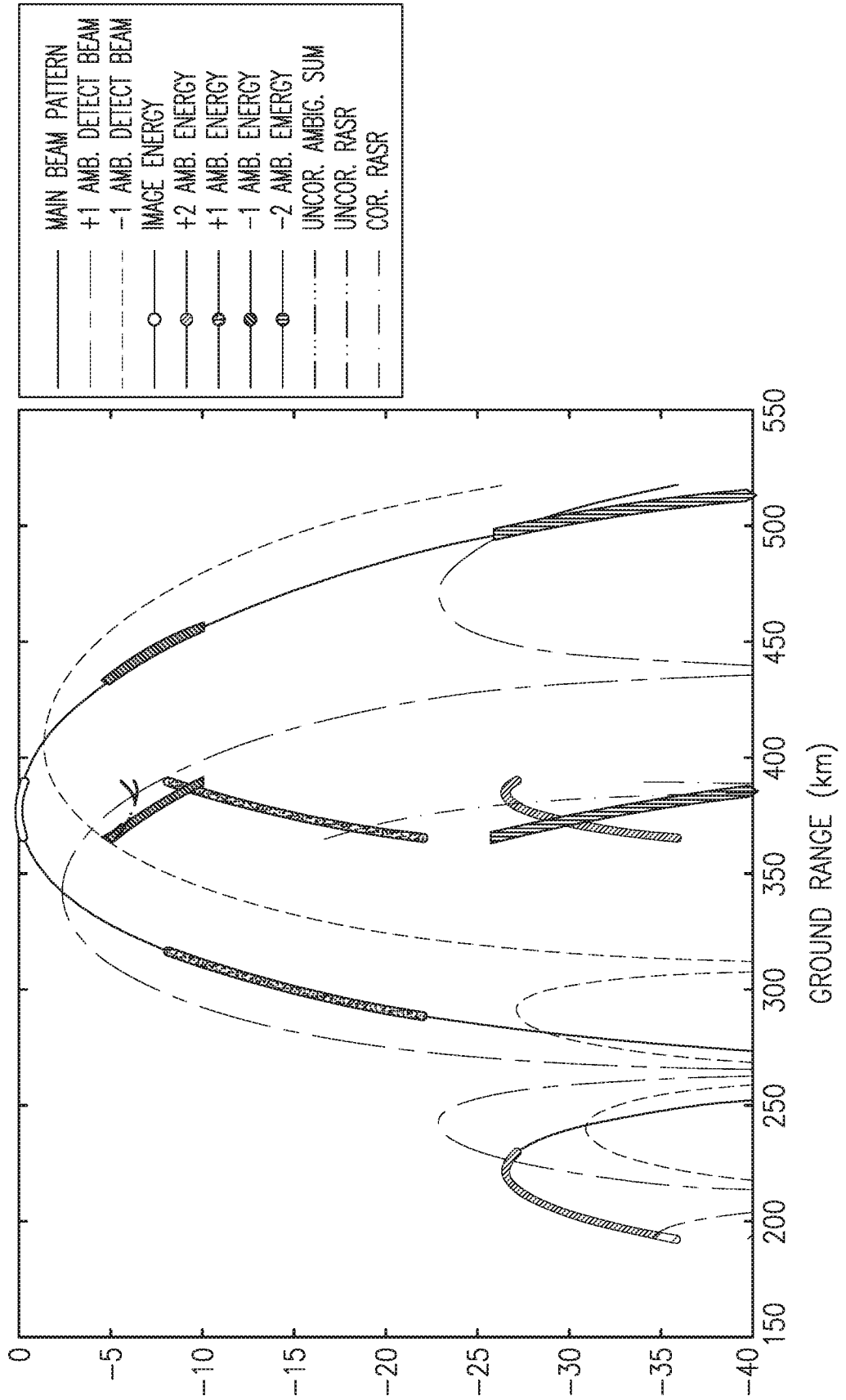

FIG. 6A

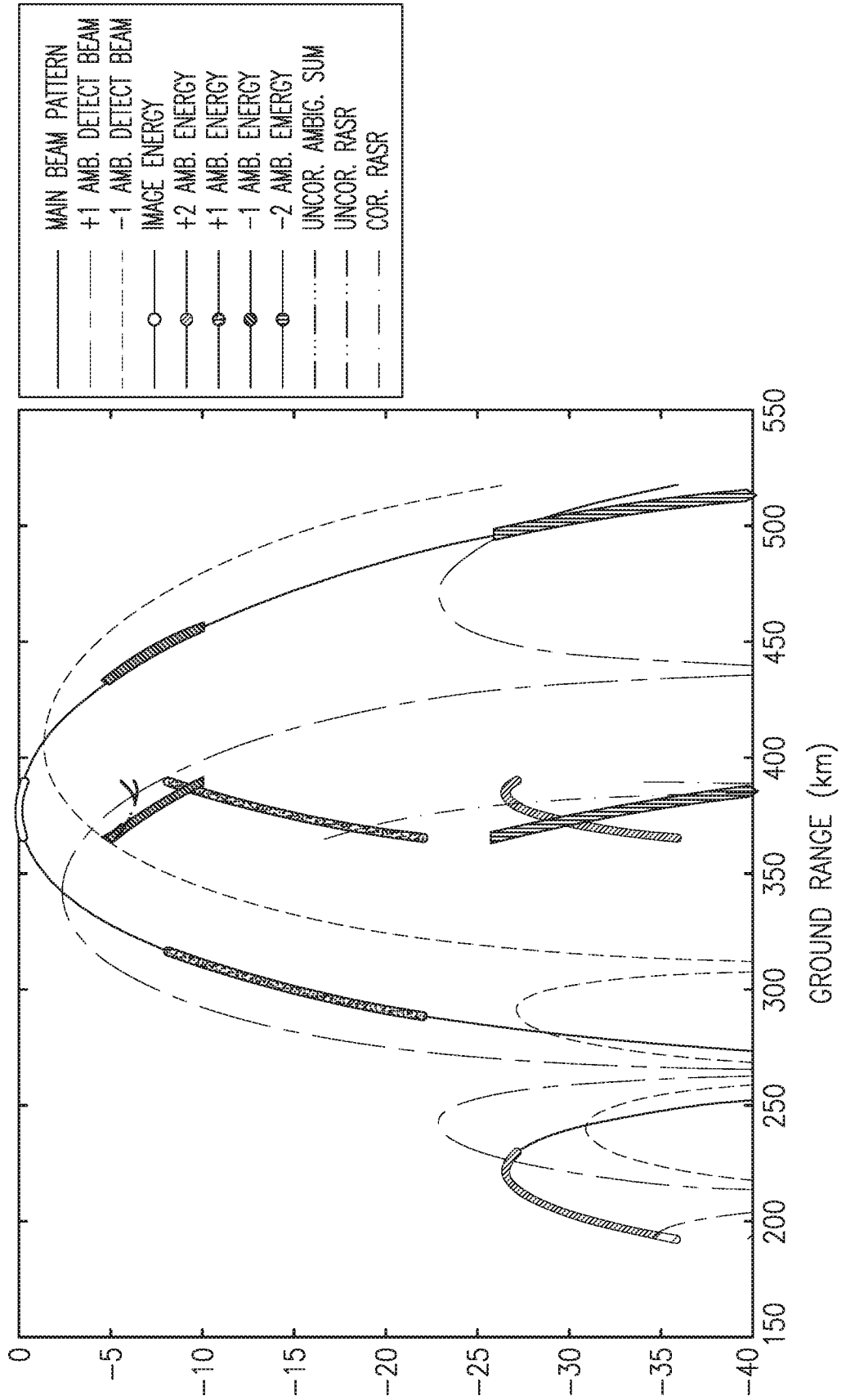

FIG. 6B

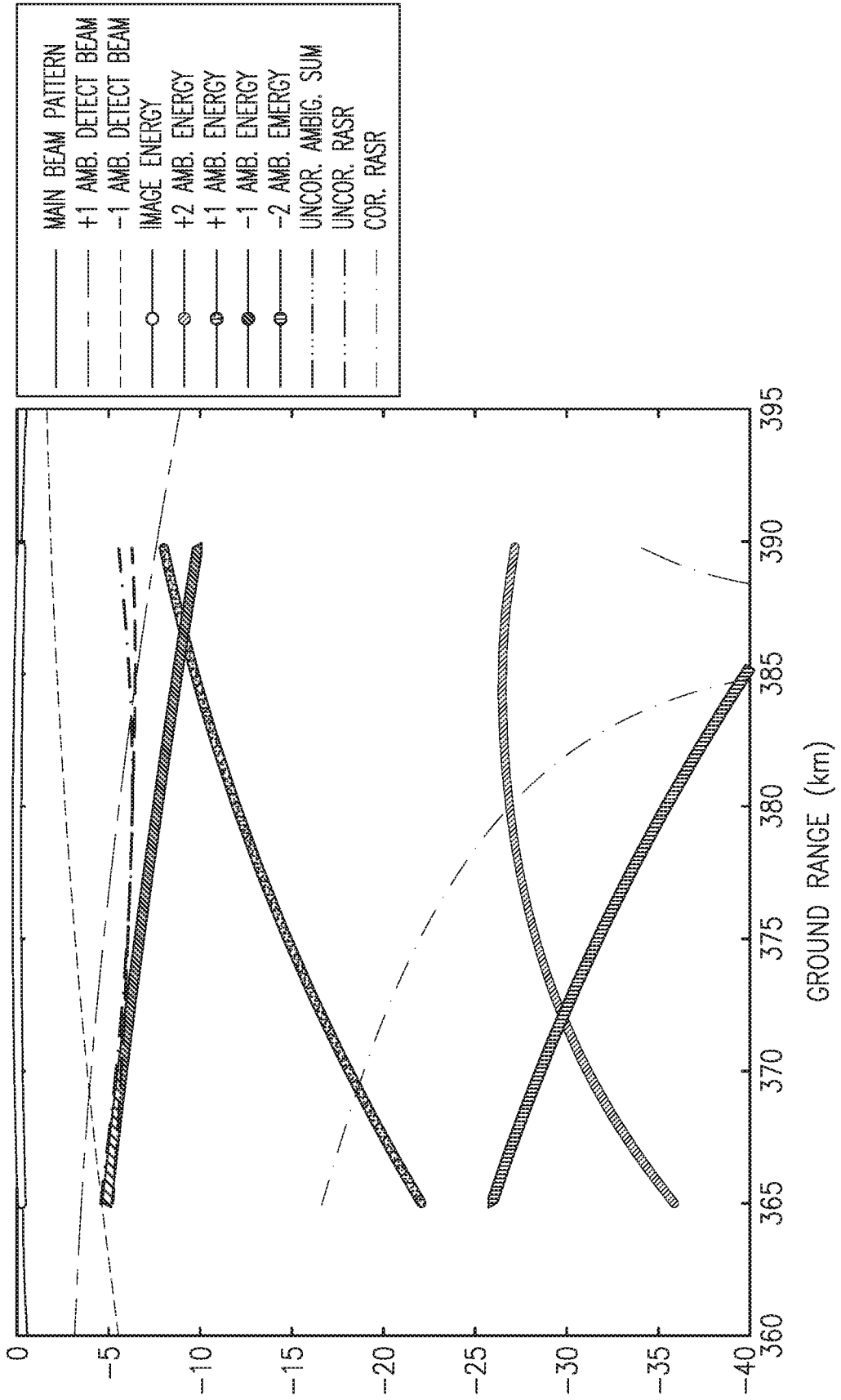

FIG. 7A

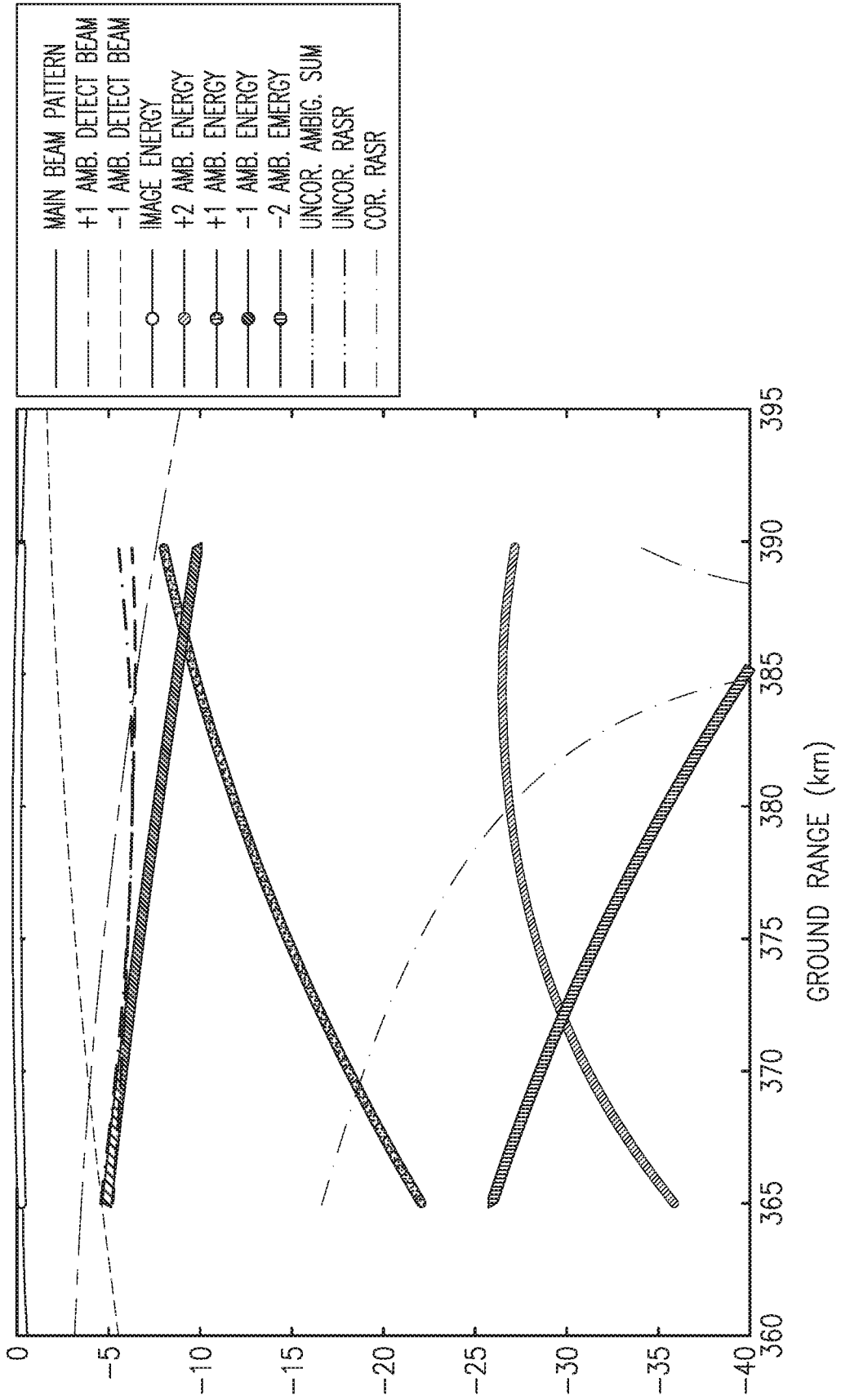

FIG. 7B

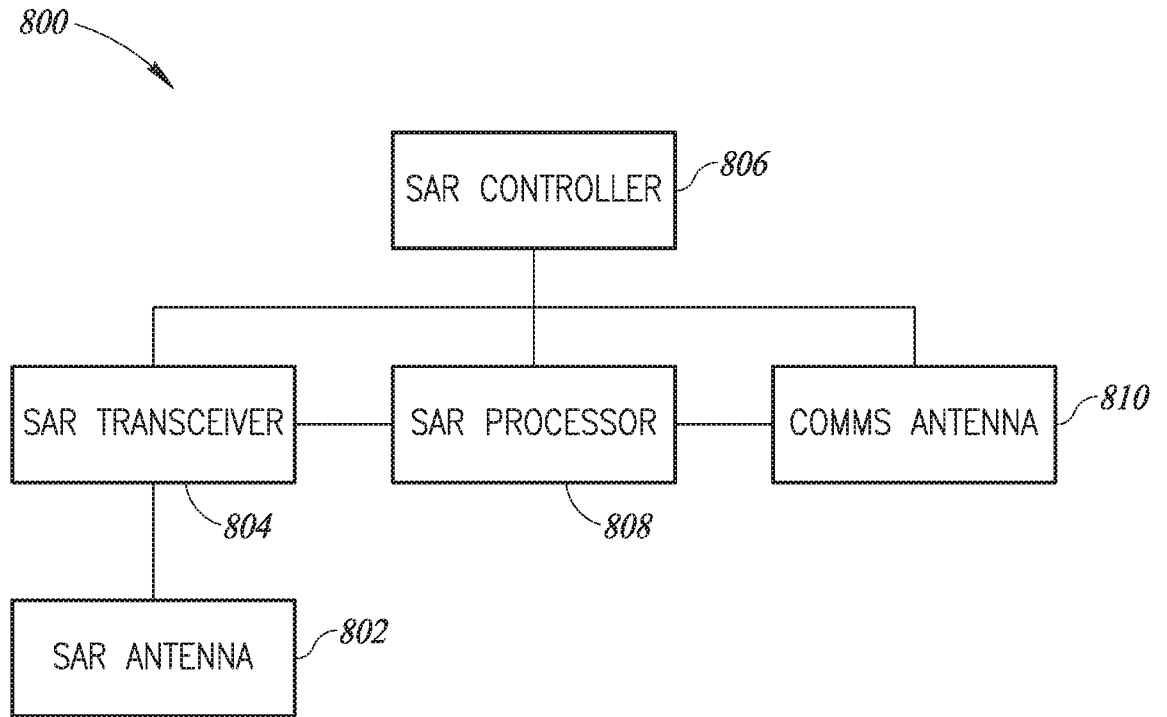

FIG. 8

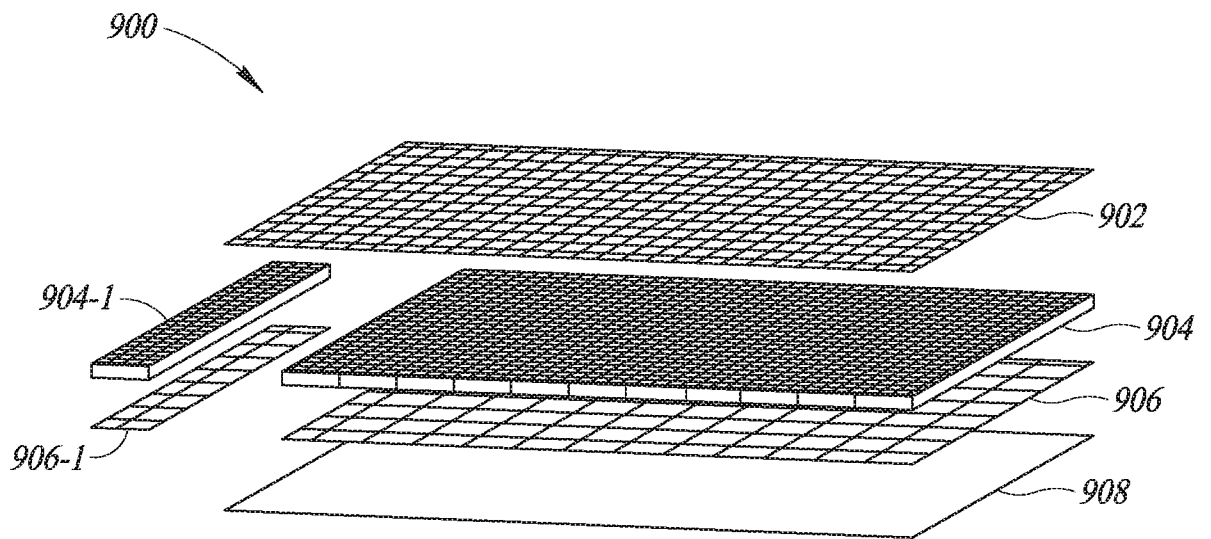

FIG. 9

13/13

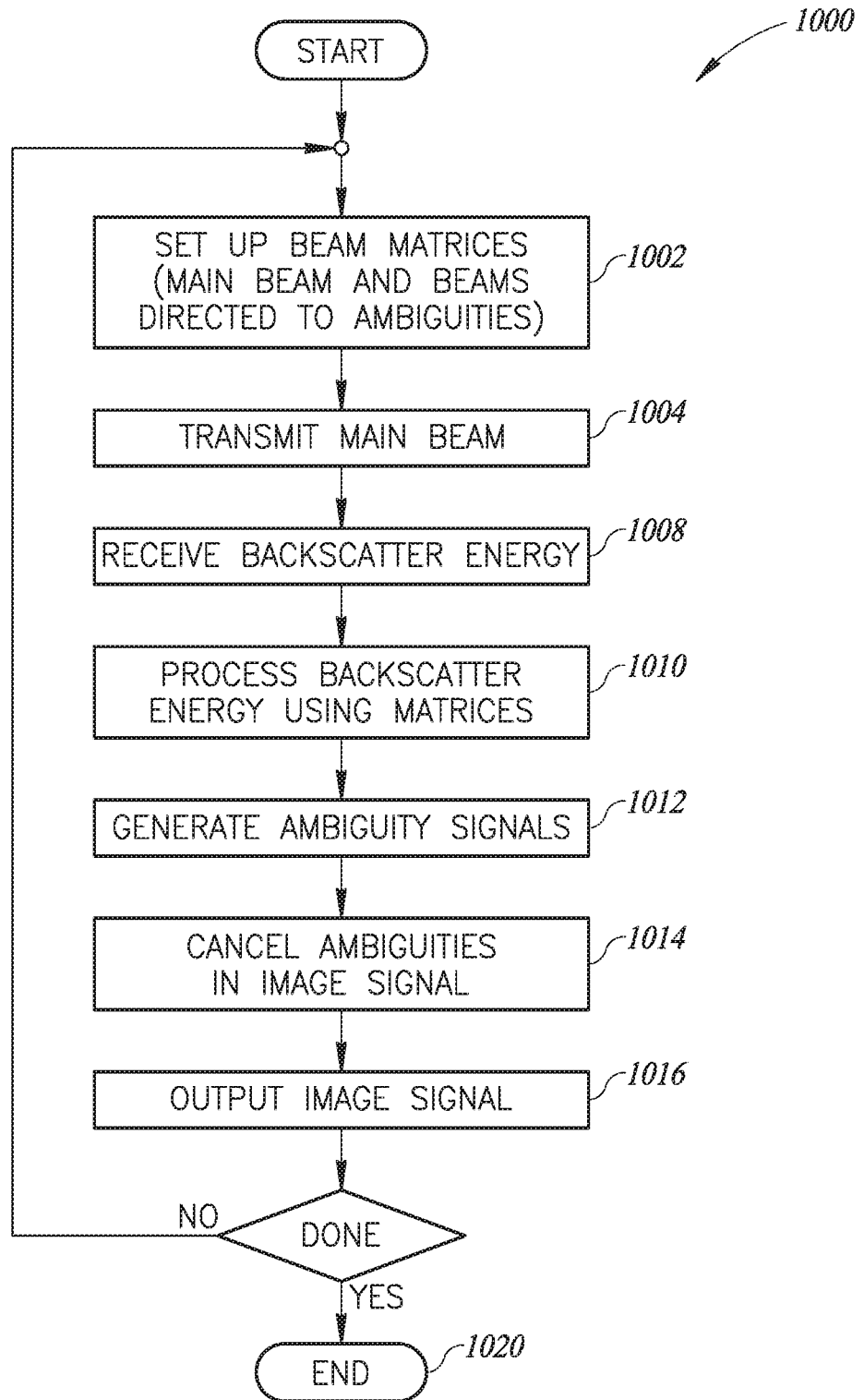

FIG. 10

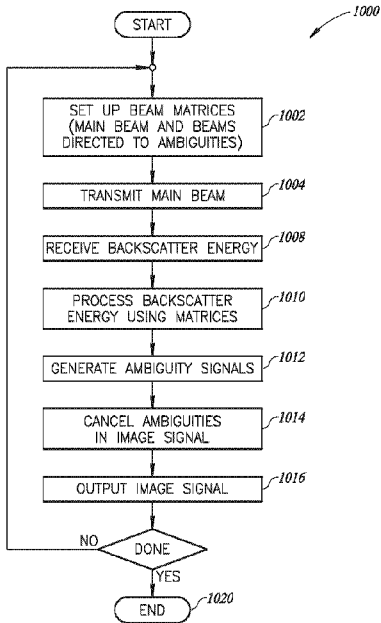

FIG. 10