



- (51) International Patent Classification:
B24B 45/00 (2006.01)
- (21) International Application Number:
PCT/US2014/041861
- (22) International Filing Date:
11 June 2014 (11.06.2014)
- (25) Filing Language: English
- (26) Publication Language: English
- (30) Priority Data:
2013-125682 14 June 2013 (14.06.2013) JP
- (71) Applicant: 3M INNOVATIVE PROPERTIES COMPANY [US/US]; 3M Center, Post Office Box 33427, Saint Paul, Minnesota 55133-3427 (US).
- (72) Inventor: YAMAHARA, Michihiro; 6-7-29, Kitashinagawa, Shinagawa-ku, Tokyo 141-8684 (JP).
- (74) Agents: BAUM, Scott A., et al.; 3M Center Office of Intellectual Property Counsel, Post Office Box 33427, Saint Paul, Minnesota 55133-3427 (US).

- (81) Designated States (unless otherwise indicated, for every kind of national protection available): AE, AG, AL, AM, AO, AT, AU, AZ, BA, BB, BG, BH, BN, BR, BW, BY, BZ, CA, CH, CL, CN, CO, CR, CU, CZ, DE, DK, DM, DO, DZ, EC, EE, EG, ES, FI, GB, GD, GE, GH, GM, GT, HN, HR, HU, ID, IL, IN, IR, IS, KE, KG, KN, KP, KR, KZ, LA, LC, LK, LR, LS, LT, LU, LY, MA, MD, ME, MG, MK, MN, MW, MX, MY, MZ, NA, NG, NI, NO, NZ, OM, PA, PE, PG, PH, PL, PT, QA, RO, RS, RU, RW, SA, SC, SD, SE, SG, SK, SL, SM, ST, SV, SY, TH, TJ, TM, TN, TR, TT, TZ, UA, UG, US, UZ, VC, VN, ZA, ZM, ZW.
- (84) Designated States (unless otherwise indicated, for every kind of regional protection available): ARIPO (BW, GH, GM, KE, LR, LS, MW, MZ, NA, RW, SD, SL, SZ, TZ, UG, ZM, ZW), Eurasian (AM, AZ, BY, KG, KZ, RU, TJ, TM), European (AL, AT, BE, BG, CH, CY, CZ, DE, DK, EE, ES, FI, FR, GB, GR, HR, HU, IE, IS, IT, LT, LU, LV, MC, MK, MT, NL, NO, PL, PT, RO, RS, SE, SI, SK, SM, TR), OAPI (BF, BJ, CF, CG, CI, CM, GA, GN, GQ, GW, KM, ML, MR, NE, SN, TD, TG).

[Continued on next page]

(54) Title: ADAPTER

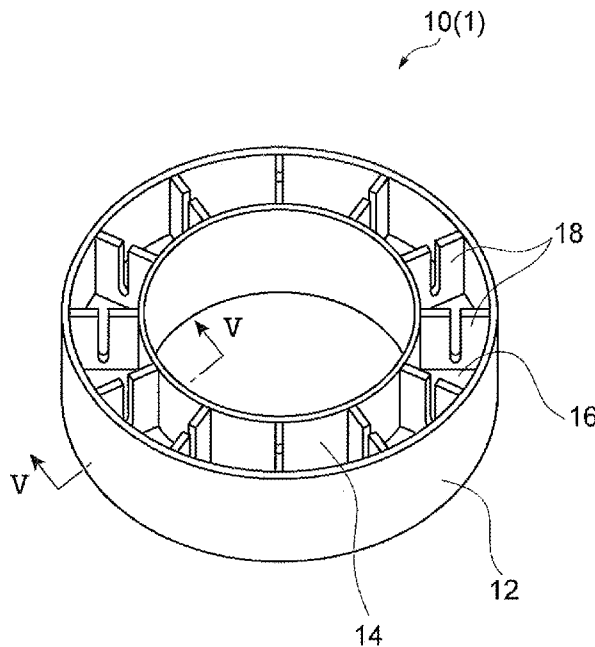

Fig. 3

(57) Abstract: An adapter according to one aspect is an adapter for fixing to a shaft of a grinding machine a grinding wheel having a through-hole where the shaft is inserted. The adapter is provided with a main body having at least a portion thereof inserted into the through-hole, the main body including an outer wall that contacts a wall of the through-hole and an inner wall that forms an opening that corresponds to the shaft, and a plurality of reinforcing parts provided in pre-determined intervals along a circumferential direction of the main body. Each reinforcing part extends from the inner wall to the outer wall, and a notch is formed in each reinforcing part.

WO 2014/201087 A1

Published:

— with international search report (Art. 21(3))

— before the expiration of the time limit for amending the claims and to be republished in the event of receipt of amendments (Rule 48.2(h))

ADAPTER

[0001] One aspect of the present invention relates to an adapter for a grinding wheel.

BACKGROUND

[0002] Grinding wheels for grinding metal members and the like are conventionally known. In Patent Document 1 given below, for example, a description is given of a grinding wheel in which a through-hole with a shaft inserted therein is formed. The grinding wheel described in the below Patent Document 1 grinds a metal member or the like by rotating the grinding wheel using the shaft.

[0003] Patent Document 1: Specification of US Reissued Patent No. 24,143

SUMMARY OF THE INVENTION

[0004] The above Patent Document 1 describes fitting the grinding wheel directly to the shaft, but if there is a significant difference in size between the shaft diameter and the grinding wheel inner diameter, it becomes difficult to assemble and match both parts.

[0005] The adapter according to one aspect of the present invention is an adapter for fixing to a shaft of a grinding machine a grinding wheel having a through-hole where the shaft is inserted. The adapter is provided with a main body having at least a portion thereof inserted into the through-hole, the main body including an outer wall that contacts a wall of the through-hole and an inner wall that forms an opening that corresponds to the shaft, and a plurality of reinforcing parts provided in predetermined intervals along a circumferential direction of the main body. Each reinforcing part extends from the inner wall to the outer wall, and a notch is formed in each reinforcing part.

[0006] Use of this type of adapter enables a gap to be easily adjusted even if a gap exists between the grinding wheel inner diameter and the shaft diameter. In other words, changing to a different size adapter allows the grinding wheel to easily attach to the shaft even if a gap exists between the grinding wheel inner diameter and the shaft diameter.

[0007] Further, because a notch is formed in the reinforcing part, the reinforcing part flexes when the adapter is inserted into the through-hole of the grinding wheel and generates a restoring force after insertion such that the reinforcing part tries to return to its original form. Because a constant pressure is applied toward the wall of the through-hole from the outer wall of the adapter by the restoring force, the adapter is securely fixed inside the grinding wheel. Therefore, if the adapter is appropriately fixed to the shaft, the grinding wheel can ultimately be securely fixed to the shaft.

EFFECT OF THE INVENTION

[0008] According to one aspect of the present invention, adjusting a gap between the grinding wheel inner diameter and the shaft diameter enables the grinding wheel to be appropriately fixed to the shaft.

BRIEF DESCRIPTION OF THE DRAWINGS

[0009] FIG. 1 is a diagram illustrating an adapter according to an embodiment inserted into a grinding wheel.

[0010] FIG. 2 is another diagram illustrating an adapter according to an embodiment inserted into a grinding wheel.

[0011] FIG. 3 is perspective view of the adapter illustrated in FIG. 1.

[0012] FIG. 4 is perspective view of the adapter illustrated in FIG. 1.

[0013] FIG. 5 is a V-V line cross-sectional view of FIG. 3.

[0014] FIG. 6 is another diagram illustrating an adapter according to an embodiment inserted into a grinding wheel.

[0015] FIG. 7 is a perspective view illustrating a modified example of an adapter according to an embodiment.

[0016] FIG. 8 is a perspective view illustrating another modified example of an adapter according to an embodiment.

[0017] FIG. 9 is a perspective view illustrating another modified example of an adapter according to an embodiment.

[0018] FIG. 10 is a perspective view illustrating another modified example of an adapter according to an embodiment.

[0019] FIG. 11 is a perspective view illustrating another modified example of an adapter according to an embodiment.

[0020] FIG. 12 is a perspective view illustrating another modified example of an adapter according to an embodiment.

[0021] FIG. 13 is a diagram illustrating the adapter illustrated in FIG. 12 inserted into another grinding wheel.

[0022] FIG. 14 is a diagram illustrating the adapter illustrated in FIG. 1 inserted into another grinding wheel.

DETAILED DESCRIPTION

[0023] Embodiments of the present invention are described below with reference to the attached drawings. In the following explanation, the same or corresponding elements are given the same reference numeral, and duplicate explanations are omitted.

[0024] First, an adapter 1 according to an embodiment will be described with reference to FIGS. 1 to 5. FIG. 1 is a diagram illustrating the adapter 1 inserted into a grinding wheel 2. FIG. 2

is another diagram illustrating the adapter 1 inserted into the grinding wheel 2. FIGS. 3 and 4 are perspective views of the adapter 1. FIG. 3 is a view from the end face of one side, and FIG. 4 is a view from the other end face. FIG. 5 is a V-V line cross-sectional view of FIG. 3.

[0025] As illustrated in FIG. 1, the adapter 1 is a member for fixing the grinding wheel 2 to a shaft S1. The grinding wheel 2 has a through-hole where the shaft S1 of a grinding machine is inserted, and the adapter 1 is inserted and securely fixed inside a wheel core 2a which forms this through-hole. The adapter 1 forms an overall ring shape to match the wheel core 2a and the shaft S1 and has a fixed width along an axis M of the shaft S1. Below, the direction along this axis M may also be referred to as the width direction of the adapter 1 and the grinding wheel 2.

[0026] The length in the width direction of the adapter 1 may be longer than the length of the width direction of the grinding wheel 2. In this case, a portion of the adapter 1 is exposed from the grinding wheel 2 as illustrated in FIG. 1. Even if the width of the adapter 1 is less than or equal to the width of the grinding wheel 2, the adapter 1 may be partially exposed when attached to the grinding wheel 2 as illustrated in FIG. 1.

[0027] Note that the type of grinding machine is not limited, and the adapter 1 may be used for any grinding machine that uses a shaft.

[0028] For example, as illustrated in FIG. 2, the adapter 1 may be used for a grinding machine having a shaft S2 formed having a screw thread C, and a nut N that corresponds to the screw thread C. The grinding wheel 2 has a through-hole where the shaft S2 of the grinding machine is inserted, and the adapter 1 is inserted inside the wheel core 2a that forms this through-hole. The grinding wheel 2 is then fixed to the shaft S2 by screwing together the nut N and the shaft S2 inserted into the through-hole of the adapter 1 and sandwiching the adapter 1 inserted into the grinding wheel 2. In the example of FIG. 2, a portion of the adapter 1 is also exposed from the grinding wheel 2.

[0029] At least one portion of a main body 10 of the adapter 1 can be inserted into the through-hole. As illustrated in FIGS. 3 and 4, the main body 10 has an outer wall 12, an inner wall 14, an annular ring part 16, and a plurality of reinforcing parts 18. Examples of material for the adapter 1 include ABS resin, nylon resin, polypropylene resin, and any of these resins with glass fiber therein, but the adapter 1 may be fabricated using materials other than these.

[0030] The outer wall 12 is a portion that contacts the wall of the through-hole of the grinding wheel 2, or in other words the wheel core 2a. The length in the width direction of the outer wall 12 may be longer than, the same as, or shorter than the length in the width direction of the grinding wheel 2. The external diameter of the main body 10, which is determined by the outer wall 12, may be the same as the diameter of the through-hole of the grinding wheel 2. The reason for making the exterior diameter of the main body 10 slightly larger than the diameter of the through-hole of the grinding wheel 2 is to securely fix the adapter 1 (main body 10) by the grinding wheel 2

[0031] The inner wall 14 is a portion that forms an opening corresponding to the shaft. The ability to optionally set the length of the width direction of the inner wall 14 is the same as with the outer wall 12.

[0032] In the present embodiment, the relationship between the inner diameter of the main body 10 determined by the inner wall 14 and the size of the diameter of the shaft is not limited. The inner diameter of the main body 10 determined by the inner wall 14 may be the same as the diameter of the shaft, or it may be slightly smaller than the diameter of the shaft as long as the shaft can pass through the opening. The reason for making the interior diameter of the main body 10 slightly smaller than the diameter of the shaft is to securely fix the adapter 1 (main body 10) by the shaft.

[0033] Alternatively, the inner diameter of the main body 10 determined by the inner wall 14 may be slightly larger than the diameter of the shaft as long as the adapter 1 that has gone through the shaft is not loose. The reason for making the interior diameter of the main body 10 slightly larger than the diameter of the shaft is to make the removal and installation of the shaft to the adapter 1 (main body 10) easier.

[0034] Even in such case, the grinding wheel 2 can be fixed to the shaft S2 by screwing together the nut N and the shaft S2 inserted into the through-hole of the adapter 1 and sandwiching the adapter 1 (main body 10) inserted into the grinding wheel 2.

[0035] The annular ring part 16 is a plate-shaped portion that connects the outer wall 12 and the inner wall 14 and extends along the radial direction from the outer wall 12 to the inner wall 14. In the present embodiment, the annular ring part 16 is provided in a position close to one end face side, as illustrated in FIGS. 3 to 5, and not in a middle portion in the width direction of the main body 10; however, the annular ring part 16 may be provided in a middle portion.

[0036] As illustrated in FIGS. 3 and 4, the plurality of reinforcing parts 18 are provided in a radial pattern on both sides of the annular ring part 16. Each reinforcing part 18 is provided so as to be interposed between the outer wall 12, the inner wall 14, and the annular ring part 16. In the present embodiment, the reinforcing parts 18 are substantially rectangular plates. It is most preferred that the thickness in the circumferential direction of the reinforcing parts 18 be set as desired, and thus, the reinforcing parts 18 do not need to be plate-shaped.

[0037] Various methods may be considered as an installation method of the reinforcing parts 18. Any number of reinforcing parts 18 may be set. The reinforcing parts 18 may also be provided on only one surface side of the annular ring part 16. In the present embodiment, the plurality of reinforcing parts 18 are provided so that a pair of reinforcing parts 18 interposes the annular ring part 16, but it is not necessary to arrange a reinforcing part 18 on one side back-to-back with a reinforcing part 18 on the other side. Further, the number of the reinforcing parts 18 on one side of the annular ring part 16 may differ from that on the other side.

[0038] A notch 20 is formed on each of the reinforcing parts 18. As illustrated in FIG. 5, the notch 20 extends along the width direction of the main body 10 from an area forming one end of the main body 10. A tip end 20a of the notch 20 is rounded (semicircular), but whether or not to round the tip end 20a is optional.

[0039] In the present embodiment, one reinforcing part 18 has one notch 20, but a plurality of notches may be formed on one reinforcing part. The length of the notch 20 provided on

the plurality of reinforcing parts 18 may be uniform or different. Furthermore, the notch 20 need not be formed on all of the reinforcing parts 18, but may be formed on only some of the reinforcing parts 18 so that the adapter 1 as a whole contracts when inserted into the grinding wheel.

[0040] As described above, one aspect of the present invention is an adapter for fixing to a shaft a grinding wheel having a through-hole where the shaft of a grinding machine is inserted. The adapter is provided with a main body where at least a portion is inserted into the through-hole and the main body includes an outer wall that contacts a wall of the through-hole and an inner wall that forms an opening that corresponds to the shaft, and a plurality of reinforcing parts provided in predetermined intervals along a circumferential direction of the main body. Each reinforcing part extends from the inner wall to the outer wall, and a notch is formed in each reinforcing part.

[0041] With this aspect, it is possible to adjust a gap between the grinding wheel inner diameter and the shaft diameter and enable the grinding wheel to be appropriately fixed to the shaft.

[0042] Further, because a notch is formed in the reinforcing part, the reinforcing part flexes when the adapter is inserted into the through-hole of the grinding wheel and generates a restoring force after insertion such that the reinforcing part tries to return to its original form. Because a constant pressure is applied toward the wall of the through-hole from the outer wall of the adapter by the restoring force, the adapter is securely fixed inside the grinding wheel. Therefore, if the adapter is appropriately fixed to the shaft, the grinding wheel can ultimately be securely fixed to the shaft.

[0043] In another aspect of the present invention, the main body has an annular ring part that connects the outer wall and the inner wall, and a plurality of reinforcing parts may be provided on the annular ring part. In this case, the reinforcing parts are supported from three directions by the outer wall, the inner wall, and the annular ring part, and the reinforcing parts which are under stress when in use can be more reliably protected.

[0044] In another aspect of the present invention, a plurality of reinforcing parts may be provided on both sides of the annular ring part. In this case, the fixing force of the adapter relative to the grinding wheel can be increased by providing more reinforcing parts that generate a restoring force.

[0045] In another aspect of the present invention, the tip end of the notches may be rounded. In this case, the area around the tip end becomes less likely to develop cracks.

[0046] In another aspect of the present invention, the inner wall may contact the shaft. In this case, a fixed pressure is applied to the shaft from the inner wall of the adapter by the restoring force of the reinforcing parts, thereby securely fixing the adapter to the shaft. Therefore, the grinding wheel can be securely fixed to the shaft by only the adapter.

[0047] Embodiments of the present invention have been described above, but the present invention is not limited to the embodiments described above. Many variations are possible as long as there is no deviation from the spirit of the invention.

[0048] If the length in the width direction of the adapter 1 is less than or equal to the length in the width direction of the grinding wheel 2, the adapter 1 as a whole can be fit into the

through-hole so that the adapter 1 does not protrude from the end of the grinding wheel as illustrated in FIG. 6. In this case, the length of the grinding wheel 2 relative to the shaft S1 can be sufficiently ensured.

[0049] In the embodiment described above, the surface of the outer wall 12 and the inner wall 14 are generally smooth, but the forms of the wall surfaces are not limited to this. The outer wall 12 and the inner wall 14 may be formed with a protruding and recessing shape. In this case, the adapter 1 is fixed to the shaft by forming a protruding and recessing shape that fits the protruding and recessing shape on the shaft or wheel core.

[0050] For example, as illustrated in a main body 21 in FIG. 7, a protruding portion 12a may be formed in the width direction on the surface of the outer wall 12. In this example, the protruding portion 12a is formed in four places at 90 degree angles.

[0051] Alternatively, as illustrated in the main body 22 in FIG. 8, a recessing portion 12b may be formed in the width direction on the surface of the outer wall 12. In this example, the recessing portion 12b is formed in four places at 90 degree angles.

[0052] Alternatively, as illustrated in the main body 23 in FIG. 9, a protruding portion 14a may be formed in the width direction on the surface of the inner wall 14. In this example, the protruding portion 14a is formed in four places at 90 degree angles.

[0053] Alternatively, as illustrated in the main body 24 in FIG. 10, a recessing portion 14b may be formed in the width direction on the surface of the inner wall 14. In this example, the recessing portion 14b may be formed in four places at 90 degree angles.

[0054] The protruding portion or the recessing portion may be formed on both the outer wall 12 and the inner wall 14. A main body 25 illustrated in FIG. 11 has a protruding portion 12a and a protruding portion 14a, and a main body 26 illustrated in FIG. 12 has a protruding portion 12a and a recessing portion 14b. Naturally, the combination of the protruding and recessing shapes formed on the outer wall 12 and the inner wall 14 is not limited to these two examples.

[0055] Here, the adapter 1 illustrated in FIGS. 7 to 12 may have a protruding portion that is integrally formed with the outer wall 12 or the inner wall 14 or it may be attached to the wall surface afterwards. Moreover, the protruding portion and the recessing portion may also be formed in two locations at a predetermined interval on the wall surface of the outer wall 12 or the inner wall 14. Also, the protruding portion or the recessing portion is provided along a reinforcing part 18, but it may be positioned between two reinforcing parts 18.

[0056] As described above, when using the adapter 1 illustrated in FIGS. 7 to 12, a protruding and recessing shape that corresponds to the grinding wheel or the shaft must be provided. An example of using the adapter 1 having the main body 26 is illustrated in FIG. 13. In this example, a recessing portion that accommodates the protruding portion 12a formed on the outer wall 12 of the main body 26 is formed on the wheel core 2b. Moreover, a protruding portion that accommodates the recessing portion 14b formed on the inner wall 14 of the main body 26 is formed on the shaft S3. In FIG. 13, the length in the width direction of the adapter 1 is less than or equal to the length in the

width direction of the grinding wheel 2, and the adapter 1 as a whole is inserted into the through-hole of the grinding wheel 2.

[0057] As described above, if the adapter 1 is appropriately fixed to the shaft, the grinding wheel can ultimately be securely fixed to the shaft.

[0058] Moreover, as illustrated in FIG. 14, the adapter 1 may be applied to a grinding wheel 3 that has a wide width. In the example of FIG. 14, the adapter 1 (main body 10) is inserted into both ends of the grinding wheel 3. Even in this modified example, the adapter 1 achieves a similar effect as that described in the above embodiment.

Claims:

1. An adapter for fixing to a shaft a grinding wheel having a through-hole where the shaft of a grinding machine is inserted, the adapter having a main body, at least a portion of the main body being inserted into the through-hole, and the main body including an outer wall contacting a wall of the through-hole and an inner wall forming an opening corresponding to the shaft; and a plurality of reinforcing parts provided in predetermined intervals along a circumferential direction of the main body, each reinforcing part extending from the inner wall to the outer wall, and a notch being formed in each reinforcing part.
2. The adapter according to claim 1, wherein the main body has an annular ring part that connects the outer wall and the inner wall and is provided with a plurality of reinforcing parts on the annular ring part.
3. The adapter according to claim 2, wherein the plurality of reinforcing parts is provided on both sides of the annular ring part.
4. The adapter according to any one of claims 1 to 3, wherein a tip end of the notch is rounded.
5. The adapter according to any one of claims 1 to 4, wherein the inner wall contacts the shaft.

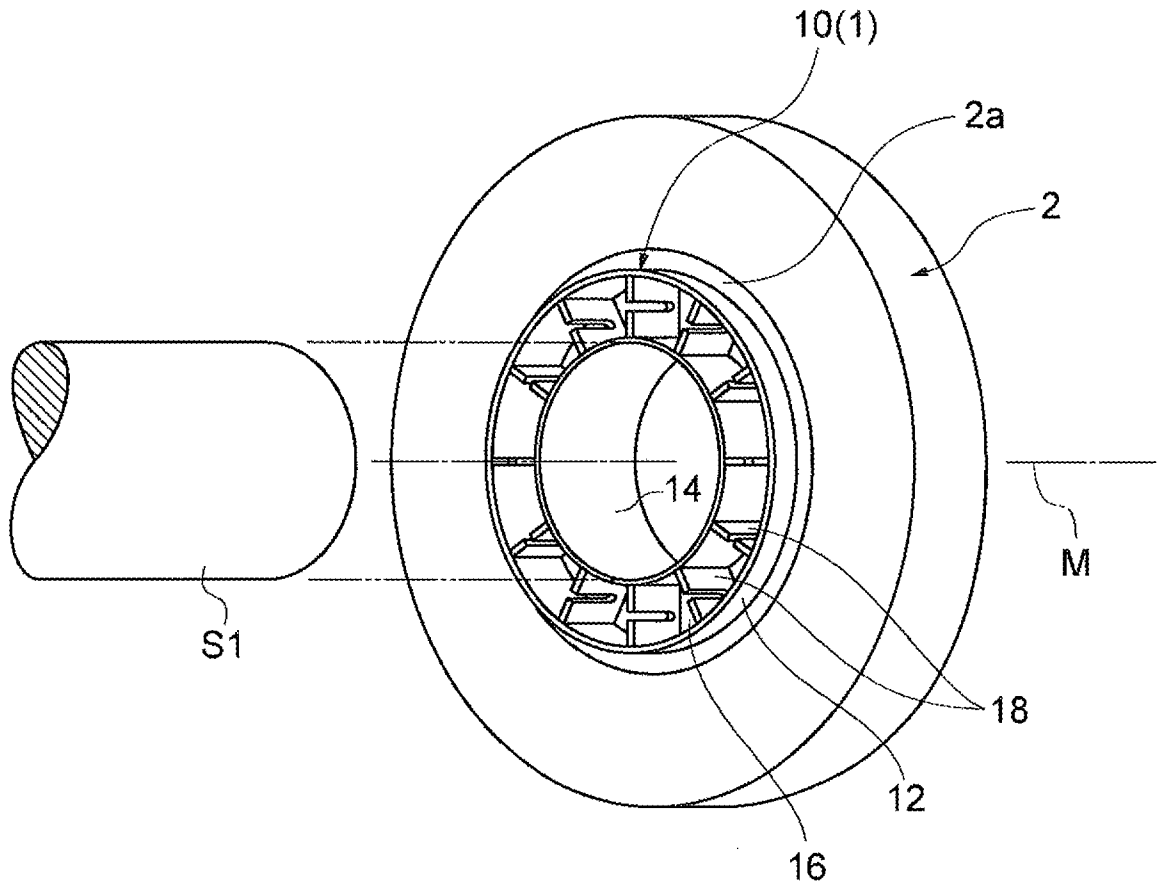

Fig. 1

2/14

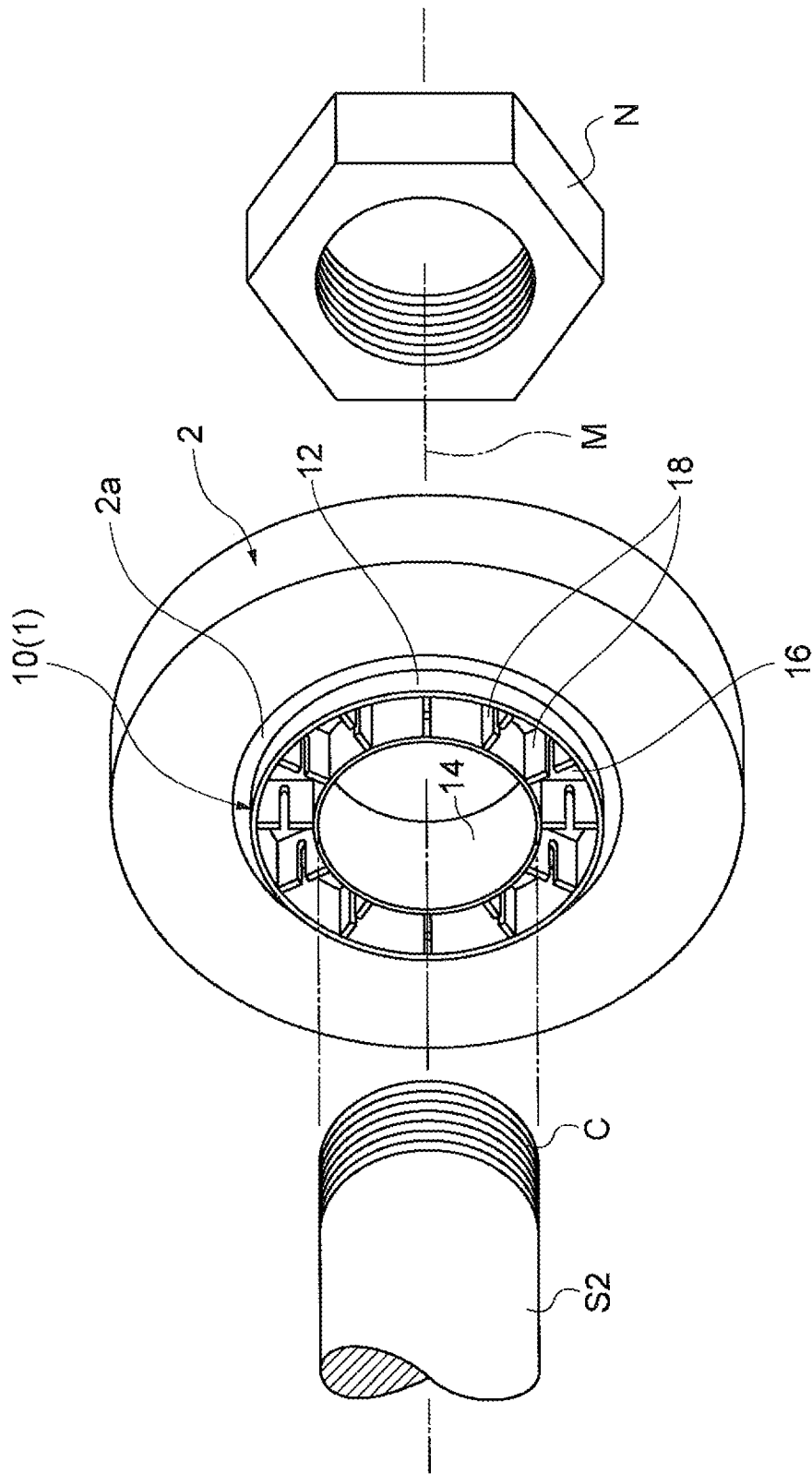

Fig. 2

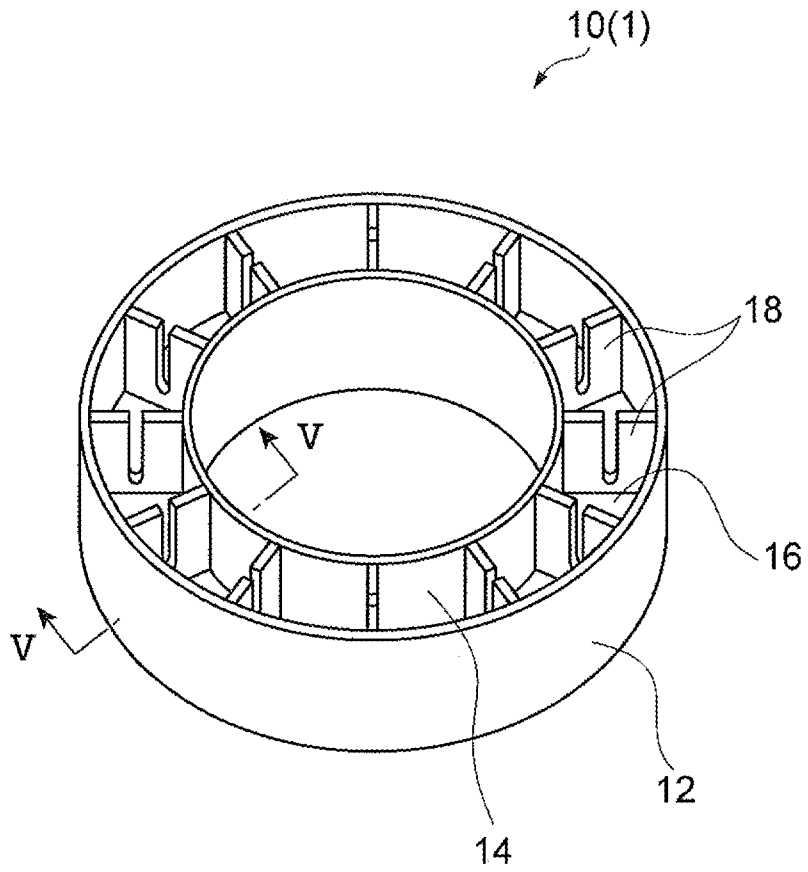

Fig. 3

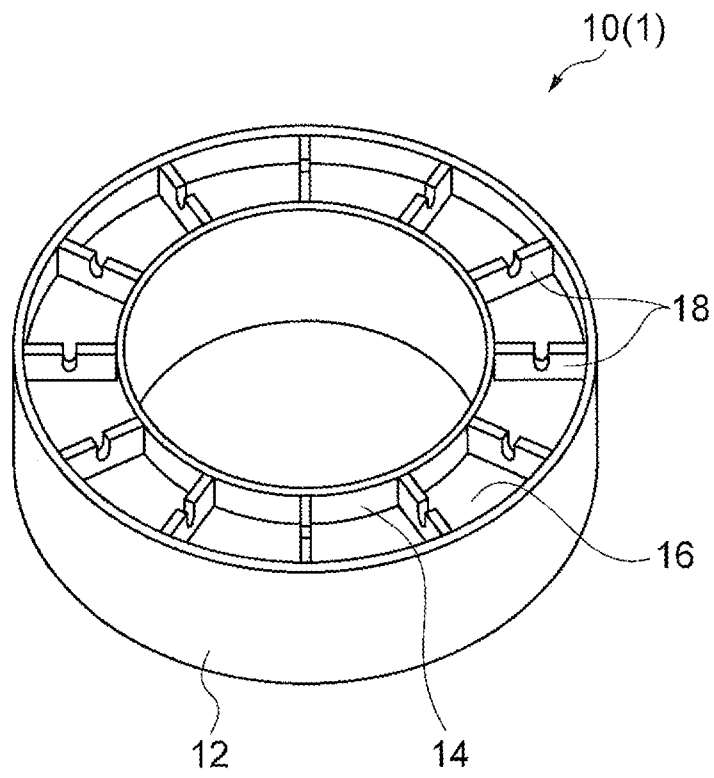

Fig. 4

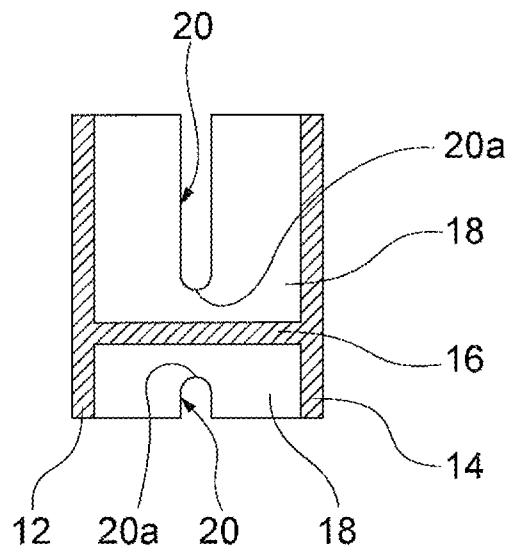

Fig. 5

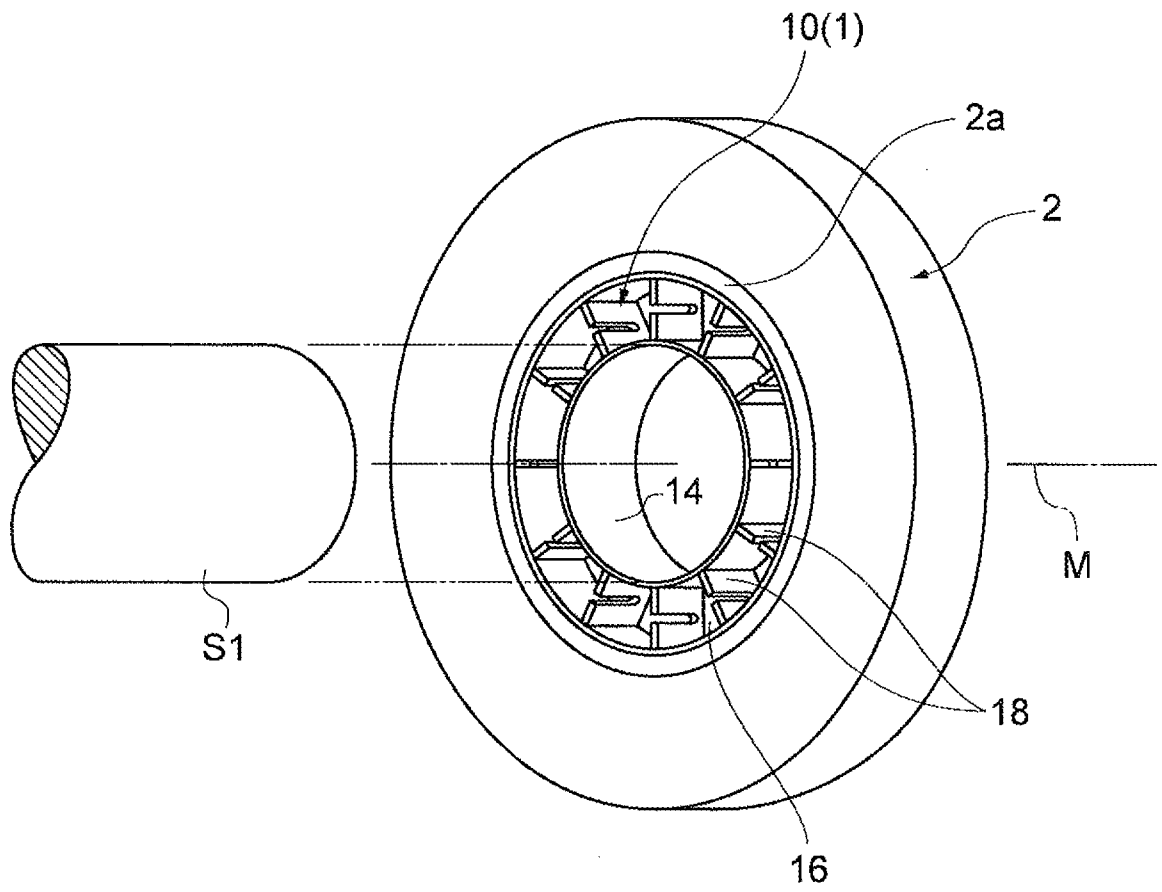

Fig. 6

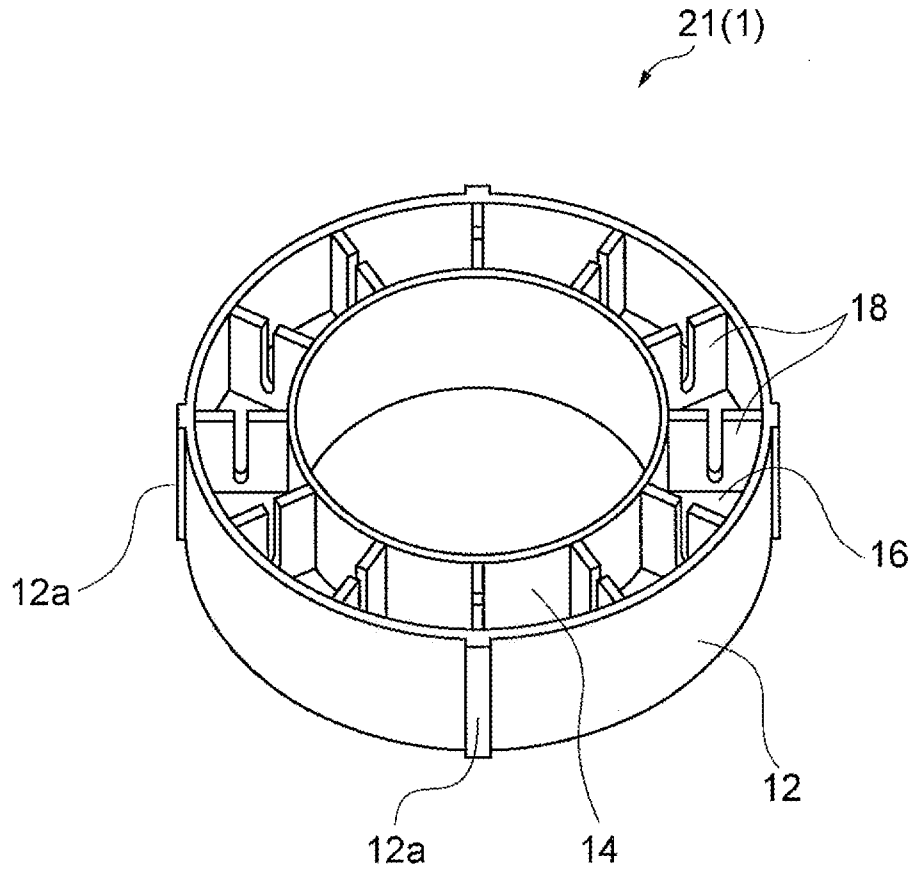

Fig. 7

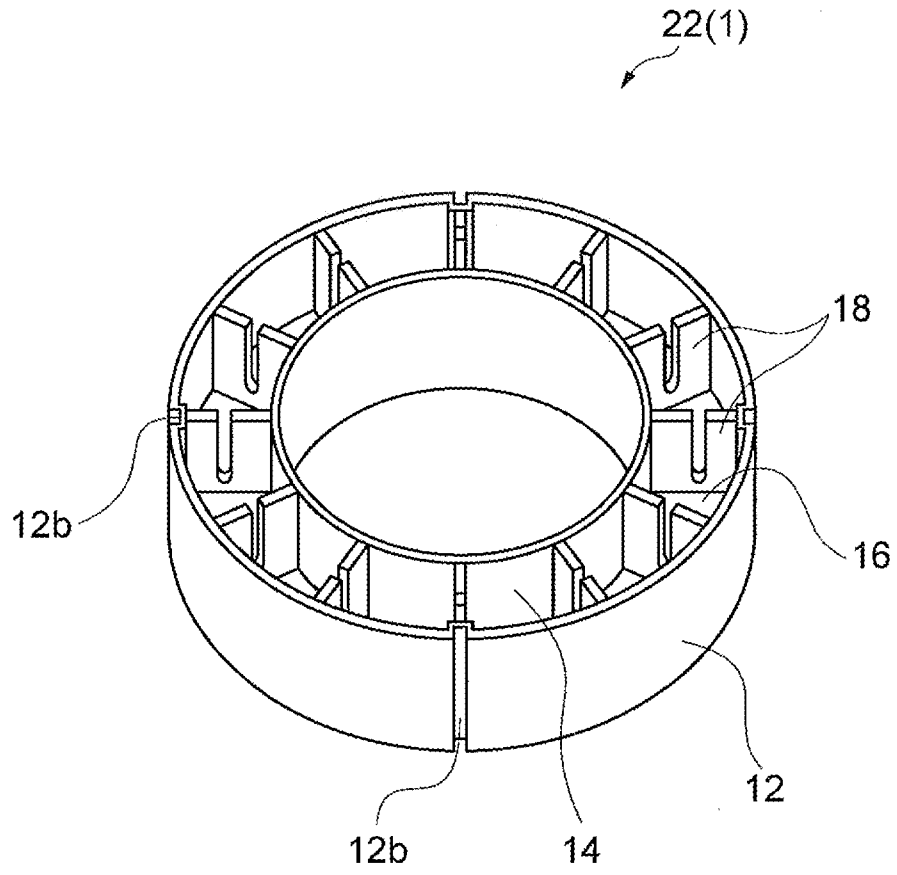

Fig. 8

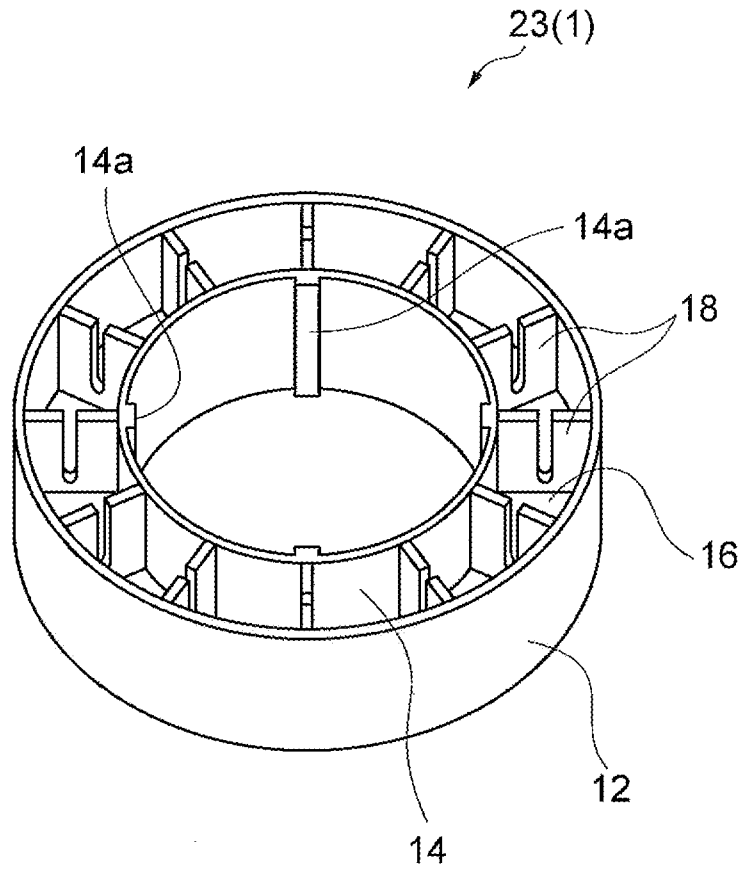

Fig. 9

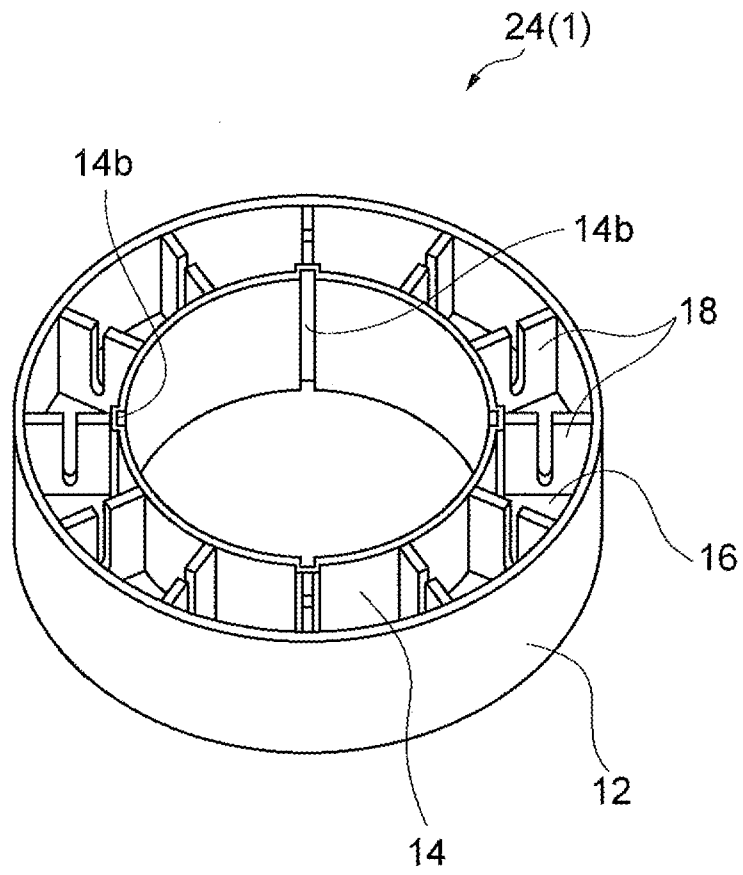

Fig. 10

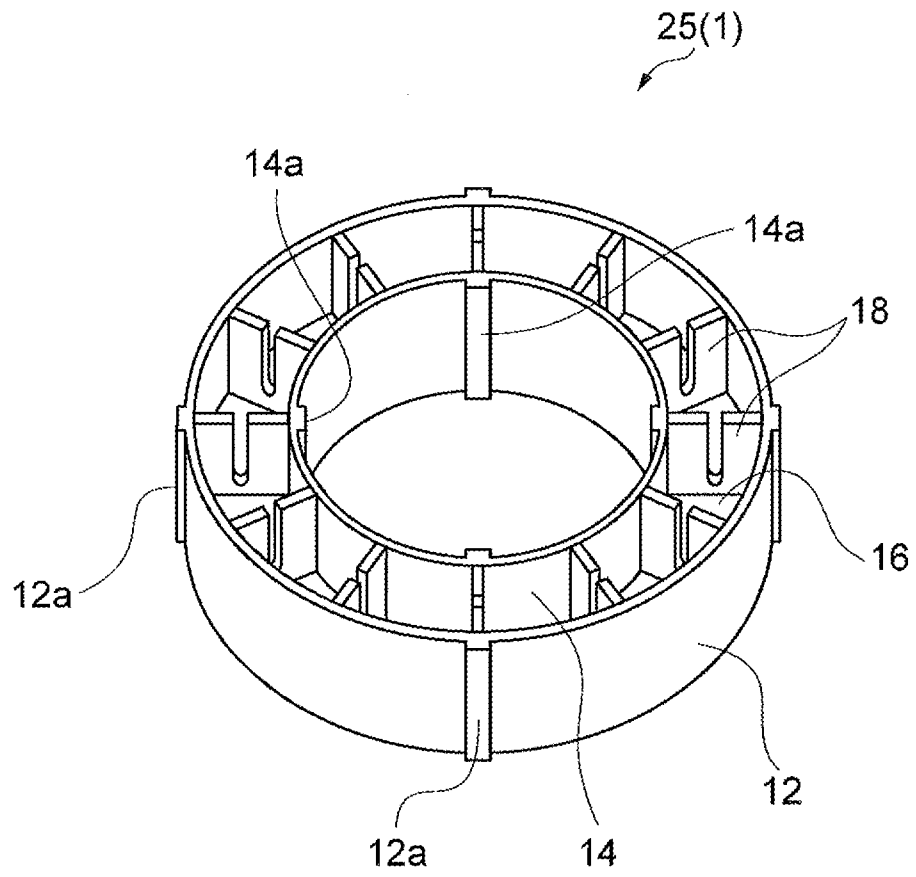

Fig. 11

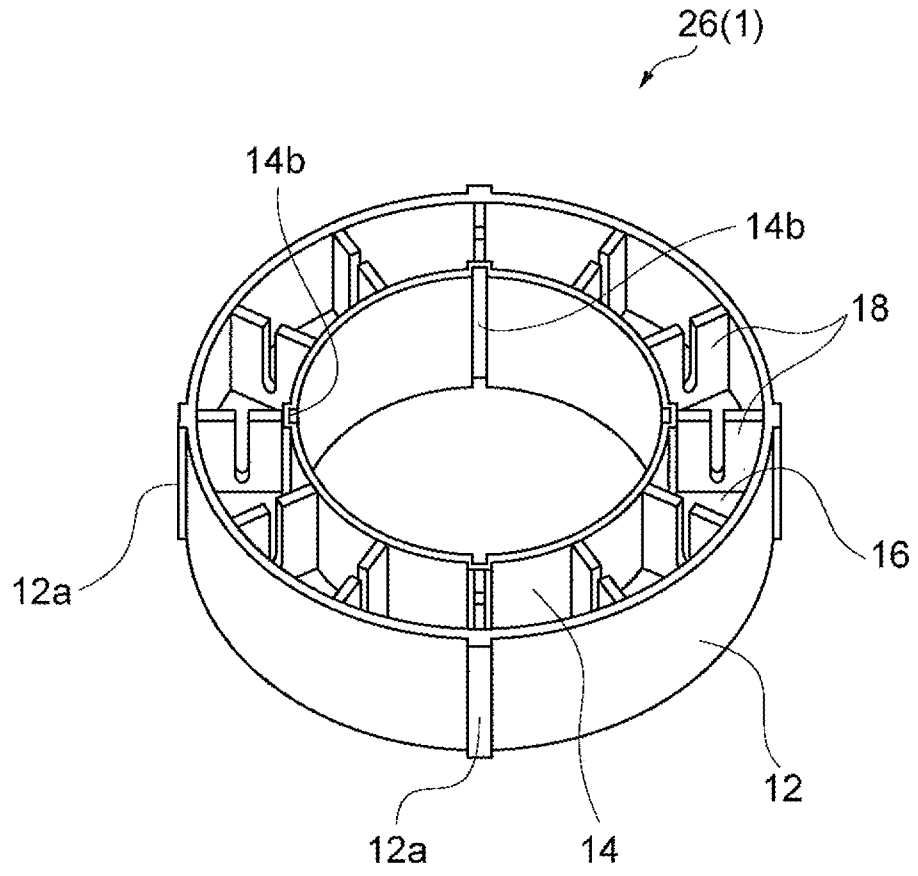

Fig. 12

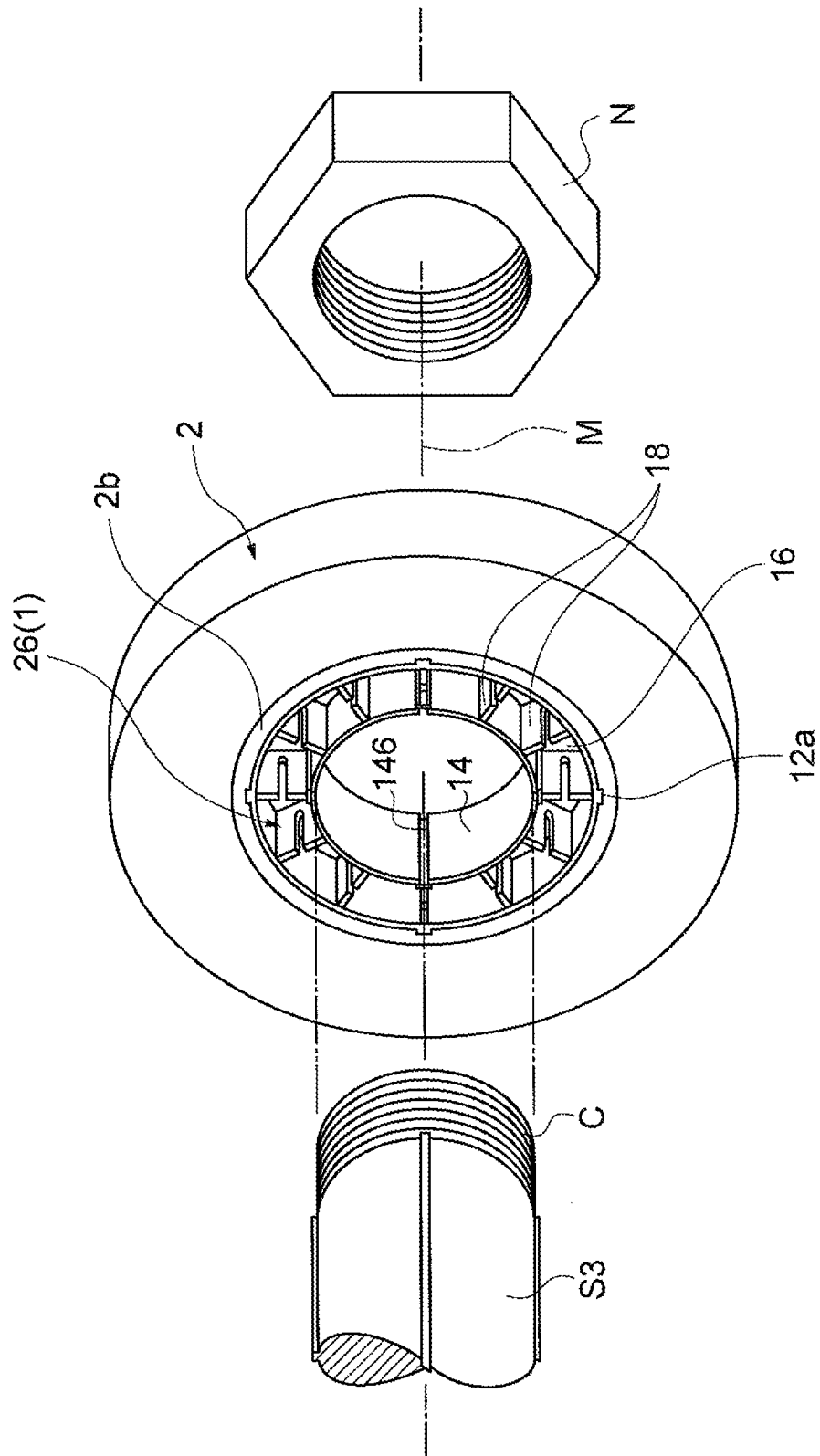

Fig. 13

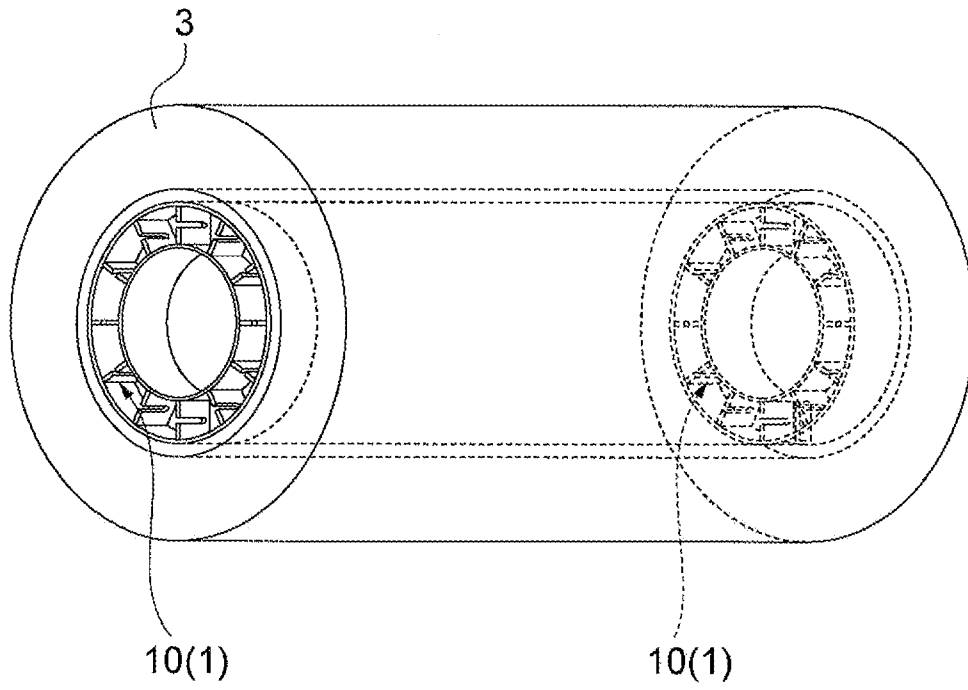

Fig. 14

A. CLASSIFICATION OF SUBJECT MATTER**B24B 45/00(2006.01)i**

According to International Patent Classification (IPC) or to both national classification and IPC

B. FIELDS SEARCHED

Minimum documentation searched (classification system followed by classification symbols)

B24B 45/00; B24B 55/02; B24B 23/02

Documentation searched other than minimum documentation to the extent that such documents are included in the fields searched

Korean utility models and applications for utility models

Japanese utility models and applications for utility models

Electronic data base consulted during the international search (name of data base and, where practicable, search terms used)

eKOMPASS(KIPO internal) & Keywords:grinding wheel, adapter, flex, reinforcing, notch

C. DOCUMENTS CONSIDERED TO BE RELEVANT

Category*	Citation of document, with indication, where appropriate, of the relevant passages	Relevant to claim No.
A	JP 2000-190217 A (MITSUBISHI MATERIALS CORP.) 11 July 2000 See paragraphs [0012]-[0036] and figures 1-5.	1-5
A	US 4878316 A (MACKAY, JR., JOSEPH H.) 07 November 1989 See column 6, lines 56-64 and figures 1, 8-9.	1-5
A	JP 11-099460 A (YANASE KABUSHIKI KAISHA) 13 April 1999 See paragraphs [0006]-[0022] and figures 1-3.	1-5
A	EP 2363241 A1 (FICAI, GIOVANNI) 07 September 2011 See paragraphs [0036]-[0071] and figures 1-3.	1-5
A	WO 01-14100 A1 (BOGALO, ADRIAN, GEORGE) 01 March 2001 See claims 1-5 and figure 1.	1-5

 Further documents are listed in the continuation of Box C. See patent family annex.

* Special categories of cited documents:

"A" document defining the general state of the art which is not considered to be of particular relevance

"E" earlier application or patent but published on or after the international filing date

"L" document which may throw doubts on priority claim(s) or which is cited to establish the publication date of another citation or other special reason (as specified)

"O" document referring to an oral disclosure, use, exhibition or other means

"P" document published prior to the international filing date but later than the priority date claimed

"T" later document published after the international filing date or priority date and not in conflict with the application but cited to understand the principle or theory underlying the invention

"X" document of particular relevance; the claimed invention cannot be considered novel or cannot be considered to involve an inventive step when the document is taken alone

"Y" document of particular relevance; the claimed invention cannot be considered to involve an inventive step when the document is combined with one or more other such documents, such combination being obvious to a person skilled in the art

"&" document member of the same patent family

Date of the actual completion of the international search

15 October 2014 (15.10.2014)

Date of mailing of the international search report

15 October 2014 (15.10.2014)

Name and mailing address of the ISA/KR

International Application Division
Korean Intellectual Property Office
189 Cheongsu-ro, Seo-gu, Daejeon Metropolitan City, 302-701,
Republic of Korea

Facsimile No. +82-42-472-7140

Authorized officer

LEE, Chang Ho

Telephone No. +82-42-481-8398

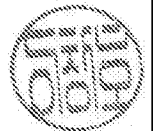

INTERNATIONAL SEARCH REPORT

Information on patent family members

International application No.

PCT/US2014/041861

Patent document cited in search report	Publication date	Patent family member(s)	Publication date
JP 2000-190217 A	11/07/2000	None	
US 4878316 A	07/11/1989	CN 1008894 B CN 87102592 A EP 0318476 A1 EP 0318476 A4 EP 0536259 A1 KR 10-1988-0701156 A US 4694615 A US 4754577 A US 4754578 A US 4760670 A US 4896463 A US 4899494 A US 4924634 A US 4934107 A US 4979336 A US 5031361 A US 5152106 A WO 87-05847 A1 WO 92-00163 A1	25/07/1990 14/10/1987 07/06/1989 20/02/1990 14/04/1993 25/07/1988 22/09/1987 05/07/1988 05/07/1988 02/08/1988 30/01/1990 13/02/1990 15/05/1990 19/06/1990 25/12/1990 16/07/1991 06/10/1992 08/10/1987 09/01/1992
JP 11-099460 A	13/04/1999	EP 0904896 B1 US 6116996 A	12/11/2003 12/09/2000
EP 2363241 A1	07/09/2011	CA 2732796 A1	05/09/2011
WO 01-14100 A1	01/03/2001	AU 2000-67431 A1	19/03/2001