

G. BEEMAN.

Stove for Railroad Cars.

No. 102,080.

Patented April 19. 1870.

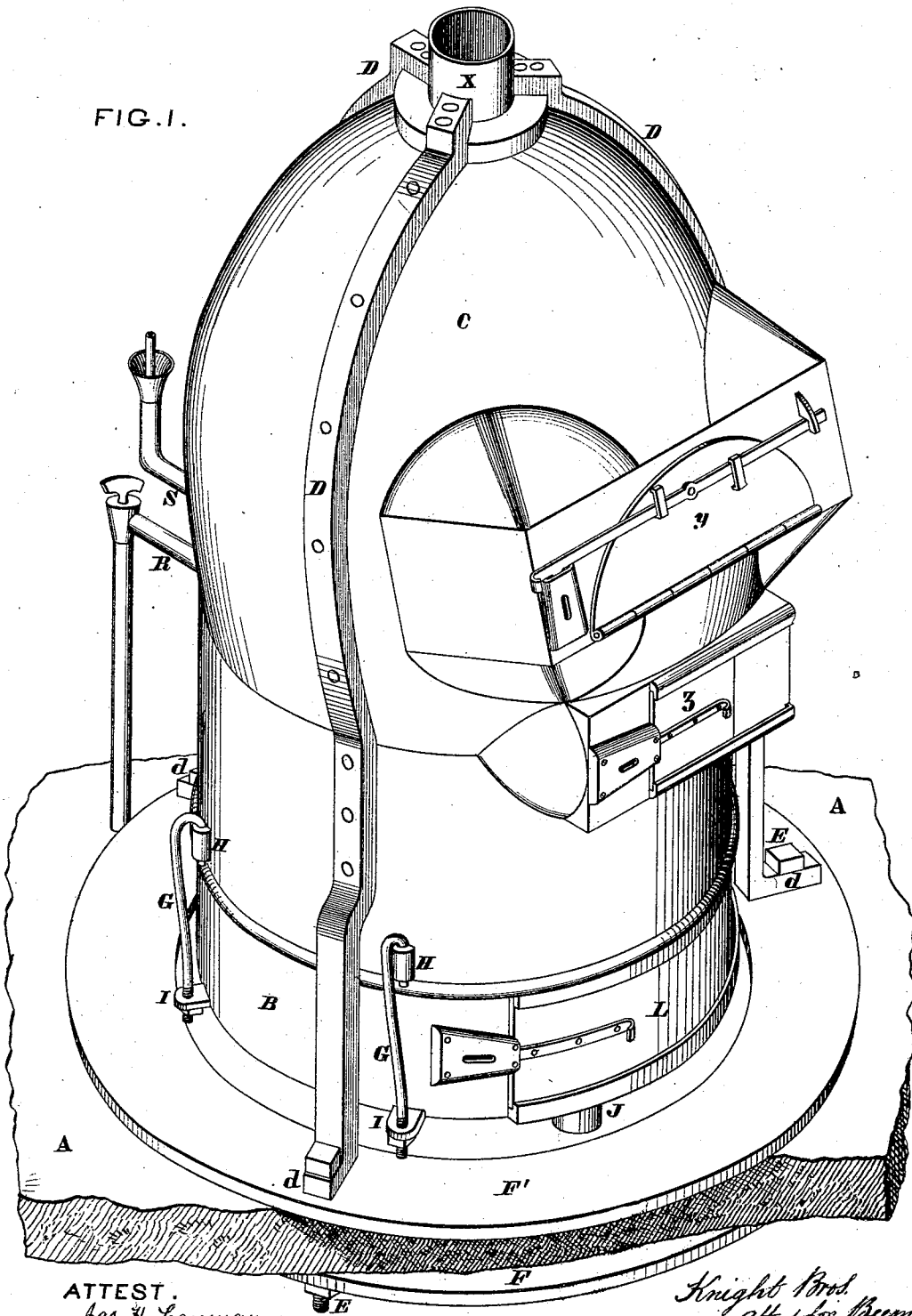

FIG. 1.

ATTEST.
Wm. H. Layman,
W. C. Hale

Knight Brod.
(attys for Beeman)

G. BEEMAN.

Stove for Railroad Cars.

No. 102,080.

Patented April 19, 1870.

FIG. 2.

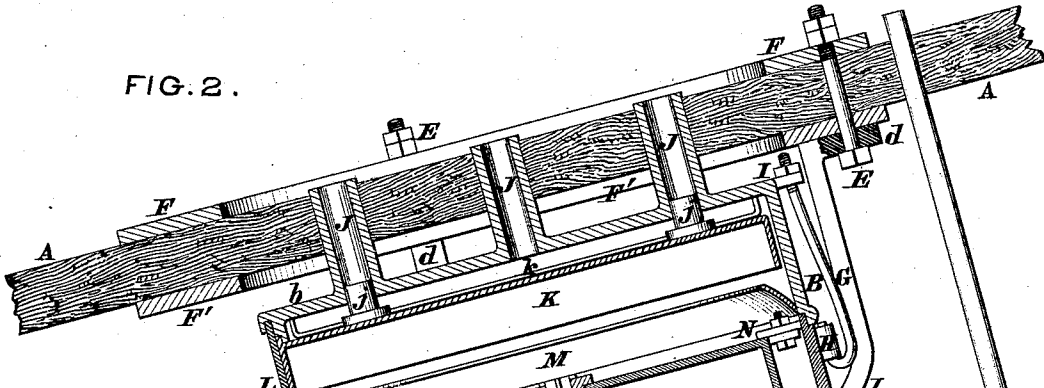

FIG. 3.

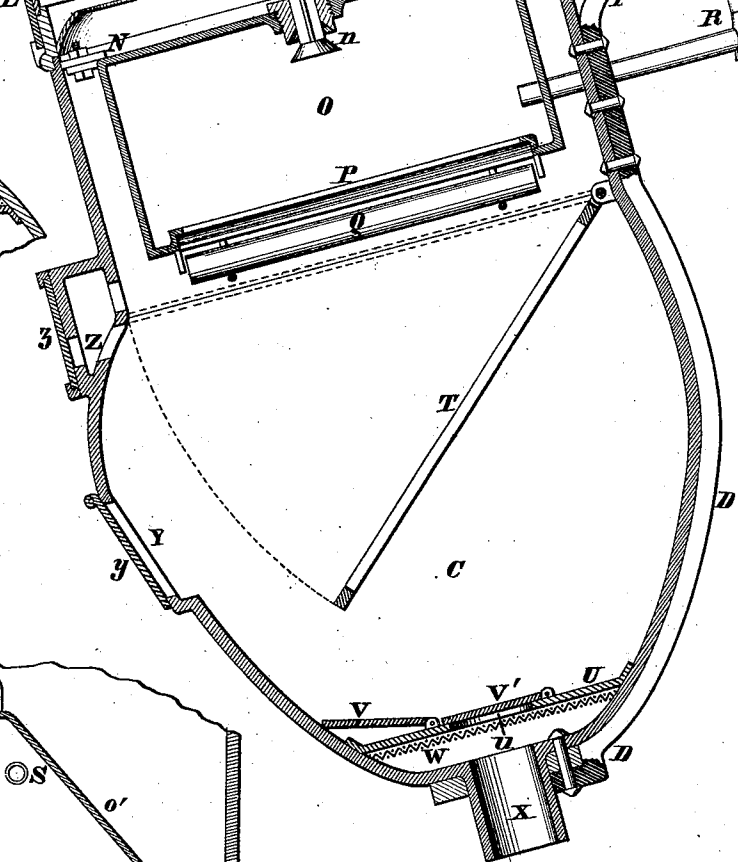
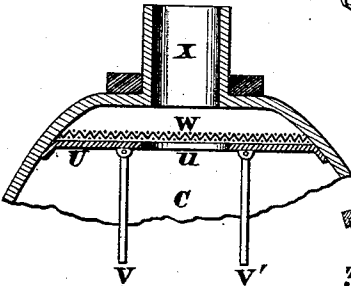
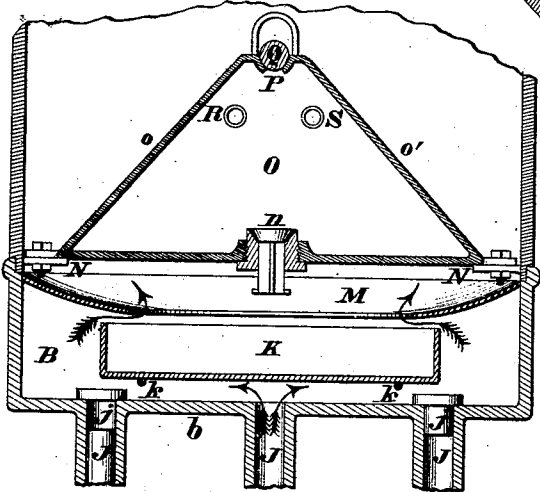

FIG. 4.



*Keight Bros.
Atty for Beeman.*

ATTEST.
W. P. Poles

United States Patent Office.

GAIN BEEMAN, OF IRONTON, OHIO.

Letters Patent No. 102,080, dated April 19, 1870.

STOVE FOR RAILROAD CARS.

The Schedule referred to in these Letters Patent and making part of the same

I, GAIN BEEMAN, of Ironton, Lawrence county, Ohio, have invented a new and useful Stove for Railroad Cars, of which the following is a specification.

Nature and Objects of the Invention.

My invention is intended to prevent the injurious effects incident to the displacement of the stove, and the escape of its burning contents in cases of collision or upsetting the car, and comprises a mode of fastening down or securing the stove to the floor or other portion of the car-bed; a peculiarly-formed and operating water-tank below the fire-grate; provisions for preventing the escape of the cinders when the car is upset; draught-inlets, under control of the conductor or attendants.

General Description with Reference to the Drawings.

Figure 1 is a perspective view of a stove embodying my invention.

Figure 2 is a vertical section of the same upset.

Figure 3 is a similar section of the upper part of the stove in its erect position.

Figure 4 is a vertical section at right angles to the plane of fig. 2 of the lower part of the stove.

A represents a portion of the floor of a railroad car. The outer portion or shell of the stove consists of a cylindrical base B and dome C, which dome is suspended within and firmly riveted to an inclosing cage or tripod, D, of wrought iron, whose feet, *d*, are firmly bolted to the car floor.

In order to give the bolts E a secure hold of the floor, I interpose two annular plates or rings F F', one, F, below, and the other one, F', above the floor through which rings the bolts pass.

The base B is suspended from the dome C, and held clear of the car floor by means of hooked rods G, which engage in eyes H on the dome, and are bolted to lugs I on the base.

The bottom *b* of the base B has a number of draught-inlets formed by pipes J, which depend through and below the car floor, and are capable of being closed by one or more caps or plugs *j*, so as to give the conductor or other responsible person more or less control of combustion by limiting the draught.

These plugs are put in or taken out at will, when the ash-pan is out, and are retained in position by the ash-pan resting upon them.

Sliding through an opening in the side of the base is an ash-pan, K, which rests upon rods *k*, and is held within the base by a locked door, L.

M represents a ledge, which, sloping inward, conducts into the pan whatever ashes drop from the fire.

Resting upon and bolted to lugs N, that project interiorly from the dome or shell is a water-tank, O, having a roof-like top, *o o'*, with a long slot, P, in its apex, for a gravitating cylindrical valve, Q, which, when the stove is capsized or overturned, opens by its own weight, so as to discharge a copious stream of water through the slot P upon the fire in the grate.

R S are respectively supply and discharge-faucets to the tank O.

n is a valve-guarded aperture in the tank bottom, which permits the entrance of air, so as to allow of a free discharge of the water in the overturned position.

T is a circular grating, hinged at one edge to the shell, so as, on the inversion of the car, to fall open, as shown in fig. 2, and by so doing to confine the fire to one side of the chamber.

U is a diaphragm near the top of the fire-chamber, and having an aperture, *u*, which, when the stove is overturned, becomes closed by one or other of the flaps or doors V V'.

Above the diaphragm U is a screen or grating, W, to prevent the escape of any embers through the neck X, when the stove is upset.

Y and Z are openings for feeding and for stirring of the fire, and are closed respectively by lock-up doors *y* and *z*.

Claims.

I claim herein as my invention—

1. The combination of the annular plates or rings F F', cage or tripod E, and bolts E, as and for the purposes set forth.
2. The arrangement of roof-formed and slotted tank O *o o'*, P, cylindrical valve Q, sloping ledge M, and base B, for the purposes set forth.
3. The provision of valve-guarded aperture *n* in the bottom of the tank, for the object stated.
4. The hinged grating T, for the purpose set forth.
5. The provision in the bottom *b* of the base B, of pipes J and plugs *j*, forming controllable draught-inlets, out of reach of irresponsible persons.

In testimony of which invention I hereunto set my hand.

GAIN BEEMAN.

Witnesses:

GEO. H. KNIGHT,
JAMES H. LAYMAN.