



(12) **DEMANDE DE BREVET CANADIEN
CANADIAN PATENT APPLICATION**

(13) **A1**

(22) Date de dépôt/Filing Date: 2019/06/18
(41) Mise à la disp. pub./Open to Public Insp.: 2020/01/11
(30) Priorité/Priority: 2018/07/11 (US16/032,168)

(51) Cl.Int./Int.Cl. *G09G 5/377* (2006.01),
G01D 21/00 (2006.01), *G02B 27/01* (2006.01),
H04L 29/10 (2006.01)
(71) Demandeur/Applicant:
THE BOEING COMPANY, US
(72) Inventeurs/Inventors:
COFFMAN, MATHEW ALBERT, US;
LEE, NATHAN CHRISTIAN, US
(74) Agent: SMART & BIGGAR LLP

(54) Titre : SYSTEME DE REALITE AUGMENTEE OFFRANT UN DISPOSITIF D'ANCRAGE PORTATIF ACTIF
(54) Title: AUGMENTED REALITY SYSTEM WITH AN ACTIVE PORTABLE ANCHOR

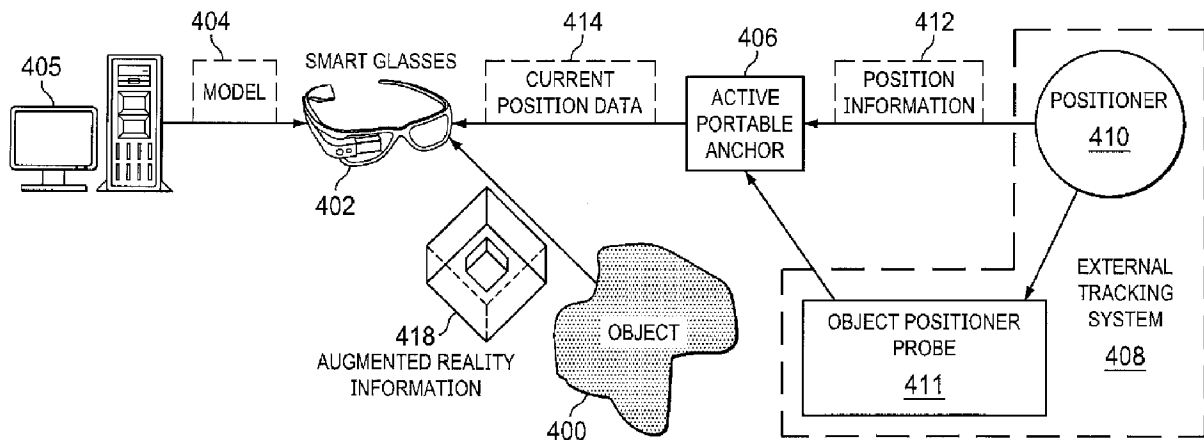

(57) **Abrégé/Abstract:**

A method, apparatus, and augmented reality system comprising a network and a communications port in the network. The communications port is configured to communicate with a portable active anchor and send a current physical anchor position of the active portable anchor relative to an object to the active portable anchor in which the current physical anchor position of the active portable anchor relative to the object is determined using a physical anchor position of the active portable anchor and a physical object position of the object.

ABSTRACT

A method, apparatus, and augmented reality system comprising a network and a communications port in the network. The communications port is configured to communicate with a portable active anchor and send a current physical anchor position of the active portable anchor relative to an object to the active portable anchor in which the current physical anchor position of the active portable anchor relative to the object is determined using a physical anchor position of the active portable anchor and a physical object position of the object.

AUGMENTED REALITY SYSTEM WITH AN ACTIVE PORTABLE ANCHOR

BACKGROUND INFORMATION

1. Field:

The present disclosure relates generally to an improved augmented reality system and, in particular, to an improved method, apparatus, and system for an augmented reality system with active anchors.

Background:

Augmented reality involves an interactive experience with a real-world environment that is augmented by information from a computer system. The information is displayed on a live view of the real-world environment seen through an augmented reality device. The information is displayed on the live view in a manner that provides descriptions or indicators about objects in the live view to a user. This information is also referred to as augmented reality information. In other cases, the augmented reality information is displayed on the live view of the real-world environment in a manner that is seamlessly interwoven such that the information perceived as part of the real-world environment is seen through the augmented reality device.

Augmented reality devices are used in many applications in real-world environments. For example, augmented reality devices can be used in manufacturing or performing maintenance on an object such as an aircraft. Augmented reality devices are used by human operators performing operations to assemble parts, fabricate parts, inspect assemblies, or other operations. Information used to augment a live view of the aircraft may include, for example, a schematic diagram, graphical indicators identifying an inconsistency, a wiring diagram, a display of components hidden under skin panels, or other types of information.

Anchors are used to describe the position of an object in the real-world environment. An anchor is also referred to as a spatial anchor and marks a position with respect to the object in the real-world environment. The anchor can be correlated to a corresponding position in a model of the object.

Displaying augmented reality information such as graphics or holograms on a live view of an object can be more accurate using the coordinate system of an anchor. These anchors can be used by the augmented reality device to orient itself. In other words, the anchors can be used by the augmented reality device to identify the position of the augmented reality device for use in displaying the augmented reality information on the live view of the object.

Currently, anchors are permanent in the real-world environment. In other words, an anchor is fixed for use in displaying augmented reality information. For example, anchor plates are a type of physical anchor and are formed or installed on an object such as a room or pipes in the room. The positions of these anchor plates are correlated to their respective positions in the model of the object to provide the augmented reality device with a reference for itself to display augmented reality information with a desired level of accuracy on the live view of object.

One drawback with using these anchors is the limited distance from which an augmented reality device can be located with respect to accuracy. As the distance of the augmented reality device from the anchor increases, the accuracy with which an augmented reality device in displaying augmented reality information on the live view of the object decreases.

For example, a distance of more than five meters from may result in an undesired level of accuracy for the augmented reality device to display the augmented reality information in positions on or proximate to the object. As a result, the number of anchors needed for desired accuracy may be greater than possible or feasible for some objects. Further, programming anchors into a model for an augmented reality system is time-consuming.

Therefore, it would be desirable to have a method and apparatus that take into account at least some of the issues discussed above, as well as other possible

issues. For example, it would be desirable to have a method and apparatus that overcome a technical problem with orienting an augmented reality device to an object in a real-world environment.

SUMMARY

In one illustrative embodiment, an augmented reality system comprises an active portable anchor, a processor system, and an augmented reality device. The active portable anchor is configured to output a current physical anchor position of the active portable anchor relative to an object. The processor system is configured to determine the current physical anchor position of the active portable anchor relative to the object using a physical anchor position of the active portable anchor and a physical object position of the object. The augmented reality device is configured to receive the current physical anchor position of the active portable anchor relative to the object from the active portable anchor. The augmented reality device is also configured to determine a current model anchor position of the active portable anchor in a model of the object using the current physical anchor position and display augmented reality information in association on a live view of the object in the augmented reality device using the current model anchor position of the active portable anchor and the model of the object. The current model anchor position of the active portable anchor in the model of the object is updated to reflect the current physical anchor position of the active portable anchor relative to the object.

In another illustrative embodiment, an augmented reality system comprises an active portable anchor and an external tracking system. The active portable anchor is configured to output a current physical anchor position of the active portable anchor relative to an object. The external tracking system is configured to determine a physical anchor position of the active portable anchor and a physical object position of the object. The current physical anchor position of the active portable anchor relative to the object that is output by the active portable anchor is

determined using the physical anchor position of the active portable anchor and the physical object position of the object.

In yet another illustrative embodiment, an augmented reality system comprises a network and a communications port in the network. The communications port is configured to communicate with a portable active anchor and send a current physical anchor position of the active portable anchor relative to an object to the active portable anchor in which the current physical anchor position of the active portable anchor relative to the object is determined using a physical anchor position of the active portable anchor and a physical object position of the object.

The features and functions can be achieved independently in various embodiments of the present disclosure or may be combined in yet other embodiments in which further details can be seen with reference to the following description and drawings.

BRIEF DESCRIPTION OF THE DRAWINGS

The novel features believed characteristic of the illustrative embodiments are set forth in the appended claims. The illustrative embodiments, however, as well as a preferred mode of use, further objectives and features thereof, will best be understood by reference to the following detailed description of an illustrative embodiment of the present disclosure when read in conjunction with the accompanying drawings, wherein:

Figure 1 is a pictorial representation of a network of data processing systems in which illustrative embodiments may be implemented;

Figure 2 is an illustration of a block diagram of an augmented reality environment in accordance with an illustrative embodiment;

Figure 3 is an illustration of a block diagram of an active portable anchor in accordance with an illustrative embodiment;

Figure 4 is an illustration of a dataflow diagram for displaying augmented reality information on a live view of an object in accordance with an illustrative embodiment;

Figure 5 is an illustration of an augmented reality environment in accordance with an illustrative embodiment;

Figure 6 is an illustration of an active portable anchor in accordance with an illustrative embodiment;

Figure 7 is an illustration of a flowchart of a process for displaying augmented reality information on a live view in accordance with an illustrative embodiment;

Figure 8 is an illustration of a flowchart of a process for outputting a current physical anchor position to orient an augmented reality device in accordance with an illustrative embodiment;

Figure 9 is an illustration of a flowchart of a process for displaying augmented reality information in accordance with an illustrative embodiment;

Figure 10 is an illustration of a flowchart of a process for orienting an augmented reality device in accordance with an illustrative embodiment;

Figure 11 is an illustration of a flowchart of a process for receiving a current physical anchor position in accordance with an illustrative embodiment;

Figure 12 is an illustration of a block diagram of a data processing system in accordance with an illustrative embodiment;

Figure 13 is an illustration of a block diagram of an aircraft manufacturing and service method in accordance with an illustrative embodiment;

Figure 14 is an illustration of a block diagram of an aircraft in which an illustrative embodiment may be implemented; and

Figure 15 is an illustration of a block diagram of a product management system in accordance with an illustrative embodiment.

DETAILED DESCRIPTION

The illustrative embodiments recognize and take into account one or more different considerations. The illustrative embodiments recognize and take into account that accuracy in positioning augmented reality information displayed on a live view of an aircraft is important in performing operations on the aircraft. For example, the

augmented reality information can be displayed on the live view to perform operations such as drilling holes, reworking an inconsistency, applying a sealant, or installing fasteners in the aircraft. In one illustrative example, the augmented reality information can show inconsistencies using visual information tags. These tags can mark the location of the inconsistencies and provide information about the inconsistencies.

The illustrative embodiments recognize and take into account that, in a dynamic environment, the use of permanent anchors is currently infeasible. Further, the illustrative embodiments recognize and take into account that techniques for programming anchors into a model for use by an augmented reality device is time-consuming. The illustrative embodiments recognize and take into account that the amount of set-up time for currently used anchors is much greater than desired.

The illustrative embodiments recognize and take into account that currently available techniques for calibrating or orienting an augmented reality device do not work well in a dynamic environment in which at least one of objects or human operators with augmented reality devices move. For example, the illustrative embodiments recognize and take into account that using fixed point or dynamic photogrammetry is taxing in resource use in augmented reality systems and requires much effort to program in features such as anchor plates on the object into the model of the object.

Further, the illustrative embodiments recognize and take into account that, with aircraft, the number of features that are usable for this type of process are few enough to be infeasible. Additionally, the illustrative embodiments recognize and take into account that the computer-aided design data would be much greater than desired without a desired resolution. The illustrative embodiments recognize and take into account that this type of technique is more suitable for smaller volumes or spaces as compared to those for an aircraft.

The illustrative embodiments also recognize and take into account that currently used anchor plates are not very useful because they are required to be in known

positions. This type of limitation makes anchor plates infeasible for use in dynamic environments in which human operators may move with respect to the aircraft.

The illustrative embodiments recognize and take into account that active portable anchors can enable augmented reality devices to quickly orient themselves to the object in an environment. The illustrative embodiments recognize and take into account that active portable anchors can be used as a calibration plate similar to current anchors, allowing an augmented reality device to recognize that an anchor is present in the real-world environment. The illustrative embodiments also recognize and take into account that an active portable anchor can also be configured to provide an augmented reality device the current position of the active portable anchor relative to the object.

The illustrative embodiments recognize and take into account that this type of solution can be implemented by utilizing a secondary location system in the form of an external tracking system. The illustrative embodiments recognize and take into account that the external tracking system operates to identify the position of the active portable anchors and relay that information through those active portable anchors, which in turn provide the information to augmented reality devices.

Thus, the illustrative embodiments provide a method, an apparatus, and a system for providing an augmented reality device an ability to locate itself within an environment using active anchors that are portable. In one illustrative example, an augmented reality system comprises an active portable anchor, a processor system, and an augmented reality device. The active portable anchor is configured to output a current physical anchor position of the active portable anchor relative to an object. The processor system is configured to determine the current physical anchor position of the active portable anchor relative to the object using a physical anchor position of the active portable anchor and a physical object position of the object.

The augmented reality device is configured to receive the current physical anchor position of the active portable anchor relative to the object from the active portable anchor. The augmented reality device is also configured to determine a current model position of the active portable anchor in a model of the object using the

current physical anchor position and display augmented reality information in association on a live view of the object in the augmented reality device using the current model anchor position of the active portable anchor and the model of the object. The model anchor position of the active portable anchor in the model of the object is dynamically updated to reflect the current physical anchor position of the active portable anchor relative to the object.

The position of an object includes the location of the object described in three dimensions. For example, the location can be described using a Cartesian coordinate system. Further, the position of the object also includes an orientation of the object. The orientation can be describe using two or more vectors in the illustrative example.

With reference now to the figures and, in particular, with reference to **Figure 1**, a pictorial representation of a network of data processing systems is depicted in which illustrative embodiments may be implemented. Network data processing system **100** is a network of computers in which the illustrative embodiments may be implemented. Network data processing system **100** contains network **102**, which is the medium used to provide communications links between various devices and computers connected together within network data processing system **100**. Network **102** may include connections, such as wire, wireless communication links, or fiber optic cables.

In the depicted example, server computer **104** and server computer **106** connect to network **102** along with storage unit **108**. In addition, client devices **110** connect to network **102**. As depicted, client devices **110** include client computer **112**, client computer **114**, and client computer **116**. Client devices **110** may be, for example, computers, workstations, or network computers. In the depicted example, server computer **104** provides information, such as boot files, operating system images, and applications to client devices **110**. Further, client devices **110** can also include other types of client devices such as mobile phone **118**, tablet computer **120**, and smart glasses **122**. In this illustrative example, some or all of client devices **110**

may form an Internet of things (IOT) in which these physical devices can connect and exchange data.

Client devices **110** are clients to server computer **104** in this example. Network data processing system **100** may include additional server computers, client computers, and other devices not shown. Client devices **110** connect to network **102** utilizing at least one of wired, optical fiber, or wireless connections.

Program code located in network data processing system **100** may be stored on a computer recordable storage medium and downloaded to a data processing system or other device for use. For example, program code may be stored on a computer recordable storage medium on server computer **104** and downloaded to client devices **110** over network **102** for use on client devices **110**.

In the depicted example, network data processing system **100** is the Internet with network **102** representing a worldwide collection of networks and gateways that use the Transmission Control Protocol/Internet Protocol (TCP/IP) suite of protocols to communicate with one another. At the heart of the Internet is a backbone of high-speed data communication lines between major nodes or host computers consisting of thousands of commercial, governmental, educational, and other computer systems that route data and messages. Of course, network data processing system **100** also may be implemented using a number of different types of networks. For example, network **102** may be comprised of at least one of the Internet, an intranet, a local area network (LAN), a metropolitan area network (MAN), or a wide area network (WAN). **Figure 1** is intended as an example, and not as an architectural limitation for the different illustrative embodiments.

As used herein, “a number of,” when used with reference to items, means one or more items. For example, “a number of different types of networks” is one or more different types of networks.

Further, the phrase “at least one of,” when used with a list of items, means different combinations of one or more of the listed items may be used, and only one of each item in the list may be needed. In other words, “at least one of” means any combination of items and number of items may be used from the list, but not all of

the items in the list are required. The item may be a particular object, a thing, or a category.

For example, without limitation, “at least one of item A, item B, or item C” may include item A, item A and item B, or item C. This example also may include item A, item B, and item C or item B and item C. Of course, any combinations of these items may be present. In some illustrative examples, “at least one of” may be, for example, without limitation, two of item A; one of item B; and ten of item C; four of item B and seven of item C; or other suitable combinations.

In one illustrative example, human operator **124** operates an augmented reality device, such as smart glasses **122**, to perform at least one of manufacturing or maintenance operations on aircraft **126**. As depicted, server computer **106** sends model **128** of aircraft **126** to smart glasses **122** for use in displaying augmented reality information to augment a live view of aircraft **126** for human operator **124**.

In this depicted example, active portable anchor **130** and external tracking system **132** provide information utilized to identify the position of smart glasses **122** relative to aircraft **126**. External tracking system **132** identifies the physical position of aircraft **126** and active portable anchor **130**. A processor system located in at least one of active portable anchor **130**, external tracking system **132**, client devices **110**, server computer **104**, or server computer **106** identifies the current physical anchor position of active portable anchor **130** relative to aircraft **126**. Active portable anchor **130** sends this current physical anchor position to smart glasses **122**.

As depicted, smart glasses **122** receives the current physical position of active portable anchor **130** from active portable anchor **130**. This current physical anchor position of active portable anchor **130** can be received by smart glasses **122** in a number of different ways. For example, the current physical anchor position can be received from at least one of a display of the current physical anchor position on active portable anchor **130** or a wireless transmission of the current physical position from active portable anchor **130**.

The current physical anchor position of active portable anchor **130** is used by smart glasses **122** to determine where to display augmented reality information on a live

view of aircraft **126**. For example, augmented reality information may be wiring for aircraft **126** located below the surface of aircraft **126**. With the current physical position, smart glasses **122** determines where to display graphics in the live view of aircraft **126** to show the wiring in the actual location of the wiring in aircraft **126**.

Smart glasses **122** determines its position relative to active portable anchor **130**. Upon calibrating itself to active portable anchor **130**, smart glasses **122** can process model **128** of aircraft **126** to display augmented reality information without user input and without using photogrammetry data of a larger model.

With respect to accuracy, active portable anchor **130** can be moved as human operator **124** moves to maintain a distance between smart glasses **122** and active portable anchor **130** such that a desired accuracy is maintained in displaying augmented reality information in positions on the live view of aircraft **126**. When active portable anchor **130** is moved, a new physical anchor position of active portable anchor **130** can be dynamically determined and provided to smart glasses **122**.

The illustration of network data processing system **100** in the components for the augmented reality system is not meant to limit the manner in which network data processing system **100** can implement it. In other illustrative examples, one or more intelligent global positioning locators may be present in addition to the ones depicted. Further, one or more users with augmented reality devices in addition to human operator **124** may be present performing operations on aircraft **126**.

In one illustrative example, network **102** includes communications port **103**. Communications port **103** is a hardware port in network **102** that is configured to provide for communications with other data processing systems or devices, such as active portable anchor **130**. The communications can be direct or indirect with one or more other devices facilitating the sending or receiving of communications. In these illustrative examples, communications port **103** is located in a network interface card, a switch, a router, or some other device.

As depicted, communications port **103** is configured to communicate with active portable anchor **130** and send a current physical anchor position of active portable

anchor **130** relative to an object, such as aircraft **126**, to active portable anchor **130** in which the current physical anchor position of active portable anchor **130** relative to the object is determined using a physical anchor position of active portable anchor **130** and a physical object position of the object. Active portable anchor **130** is configured to output the current physical anchor position of active portable anchor **130** relative to an object, such as aircraft **126**.

Further, an augmented reality device, such as smart glasses **122**, is configured to receive the current physical anchor position of active portable anchor **130** relative to the object from active portable anchor **130**. Smart glasses **122** are configured to determine a current model anchor position of active portable anchor **130** in model **128** of the object using the current physical anchor position and display augmented reality information in association on a live view of the object in the augmented reality device using the current model anchor position of active portable anchor **130** and model **128** of the object. The current model anchor position of active portable anchor **130** in model **128** of the object is dynamically updated to reflect the current physical anchor position of active portable anchor **130** relative to the object.

Thus, a technical problem with orienting an augmented reality device to an object in a real-world environment can be overcome in network data processing system **100**. One or more technical solutions may provide a technical effect of enabling an augmented reality device, such as smart glasses **122**, to orient itself with an anchor, such as active portable anchor **130**. In one or more technical solutions, active portable anchor **130** can be moved to different locations relative to an object, such as aircraft **126**, enabling maintaining a desired distance between smart glasses **122** and active portable anchor **130**, which results in maintaining a desired level of accuracy in displaying augmented reality information on a live view in smart glasses **122**. As a result, one or more of the technical solutions using active portable anchor **130** enables human operator **124** to perform operations on aircraft **126** with a desired level of accuracy when relying on the display of augmented reality information on a live view in smart glasses **122**. For example, when the operation is a manufacturing operation such as drilling a hole, the locations of holes can be

indicated in augmented reality information on the live view of aircraft **126** with a desired level of accuracy for drilling the hole.

Turning next to **Figure 2**, an illustration of a block diagram of an augmented reality environment is depicted in accordance with an illustrative embodiment. In this illustrative example, the different components shown in block form in augmented reality environment **200** can be implemented using components shown in network data processing system **100** in **Figure 1**.

Augmented reality environment **200** is an environment in which augmented reality system **202** is configured to augment live view **204** of object **206** with augmented reality information **208** seen by human operator **210** utilizing augmented reality device **212**. Object **206** may take a number of different forms. For example, object **206** can be aircraft **126** in **Figure 1**. Further, object **206** also can be selected from a mobile platform, a stationary platform, a land-based structure, an aquatic-based structure, a space-based structure, a commercial aircraft, a rotorcraft, a surface ship, a tank, a personnel carrier, a train, a spacecraft, a space station, a satellite, a submarine, an automobile, a power plant, a bridge, a dam, a house, a manufacturing facility, a building, a fuselage, an engine, a wing, a skin panel, a landing gear assembly, a monument, and other suitable objects.

In this illustrative example, augmented reality device **212** is a physical hardware device and is selected from one of a head-mounted display, an optical see-through head-mounted display, a mobile phone, a tablet computer, smart glasses, wearable computer glasses, or some other suitable hardware system that can be moved and held or worn by human operator **210**.

As depicted, live view **204** may be provided by augmented reality device **212** as a video feed on a display or by using transparent, see-through displays or lenses, such that the user is able to see the physical real-world environment through the display in augmented reality device **212**.

For example, live view **204** can be seen on a display for augmented reality device **212** in the form of a head-mounted display, smart glasses, or a tablet computer. Augmented reality information **208** can be superimposed on the display in this type

of augmented reality device **212**. In other illustrative examples, live view **204** may be provided indirectly to a display in which other information is displayed on live view **204**. Live view **204** can be provided using a camera system that displays images or video on a display device in augmented reality device **212**.

In another illustrative example, live view **204** may be seen directly by human operator **210** of augmented reality device **212** with augmented reality information **208** being displayed over what the user sees on live view **204**. When live view **204** is seen directly by the user, the detection of live view **204** can be performed by using a sensor system, such as a camera system for augmented reality device **212**. As depicted, augmented reality information **208** augments live view **204** and can take a number of different forms. For example, augmented reality information **208** may be selected from at least one of a schematic diagram, a user input window, an instruction, a graphic for a hidden structure, or holograms for components below the surface of object **206** that are invisible on live view **204** of object **206**. The components may be, for example, selected from at least one of wiring, a pipe, composite layers, an inconsistency, a joint, a line replaceable unit, or other components that may be in object **206**.

In another illustrative example, augmented reality information **208** may include a graphical indicator drawing attention to a portion of object **206**. For example, the graphical indicator may draw attention to an inconsistency such as a delamination, a crack, worn paint, an incorrect dimension, or other types of inconsistencies.

As another example, the graphical indicator may draw attention to the location in which an operation is to be performed. This operation may be, for example, a drilling operation, a fastener installation operation, an inspection operation, or some other suitable type of operation that may be used for manufacturing or maintenance of object **206**.

Further, augmented reality information **208** also may prompt human operator **210** to provide user input to verify that a change should be made to resolve an inconsistency in object **206**. In still another illustrative example, augmented reality information **208** can provide a visualization of user input made by human operator

210. For example, augmented reality information **208** may include graphical indicators that show locations where human operator **210** or another human operator has “marked” inconsistencies on object **206**.

As depicted, augmented reality system **202** includes a number of different components. In this example, augmented reality system **202** comprises active portable anchor **214**, external tracking system **216**, processor system **218**, and augmented reality device **212**.

Active portable anchor **214** is configured to output current physical anchor position **220** of active portable anchor **214** relative to physical object position **224** of object **206**.

As depicted, processor system **218** is a physical hardware system that includes one or more processor units. When more than one processor unit is present, those processor units may communicate with each other using a communications medium. When the processor units are located in the same data processing system, the communications medium may be a bus or busses in the data processing system. When the processor units are located in different data processing systems, the communications medium may be the bus or busses and a network. The processor system can be selected from at least one of a central processing unit (CPU), a graphics processing unit (GPU), a multicore processor, a physics processing unit (PPU), a digital signal processor (DSP), a network processor, or some other suitable type of processor.

In this illustrative example, processor system **218** can be located in one or more different locations. For example, processor system **218** can be located in at least one of active portable anchor **214**, external tracking system **216**, or in some other data processing system in augmented reality environment **200**.

As depicted, processor system **218** is configured to determine current physical anchor position **220** of active portable anchor **214** relative to object **206** using physical anchor position **222** of active portable anchor **214** and physical object position **224** of object **206**.

In this illustrative example, external tracking system **216** is a physical hardware system. External tracking system **216** includes at least one of a laser tracker, a laser scanner, a camera, a displacement sensor, a measurement sensor, a probe, or some other type of external tracking system.

External tracking system **216** is configured to determine physical anchor position **222** of active portable anchor **214** and physical object position **224** of object **206**. Physical anchor position **222** and physical object position **224** are described using tracking coordinate system **226** for external tracking system **216**.

In this depicted example, physical object position **224** can be placed into object coordinate system **228** for object **206**. A part of object **206** can be designated as a reference point or origin.

For example, if object **206** is an aircraft, the origin can be the nose tip of the aircraft. Physical anchor position **222** can be converted or correlated to object coordinate system **228**. Object coordinate system **228** is the coordinate system used in model **234** of object **206**.

The correlation is made such that physical anchor position **222** in tracking coordinate system **226** is converted to current physical anchor position **220** in object coordinate system **228** in which current physical anchor position **220** of active portable anchor **214** is relative to object **206**. In other words, current physical anchor position **220** is relative to a reference point such as an origin for object **206** in object coordinate system **228**.

In other words, physical anchor position **222** and physical object position **224** in tracking coordinate system **226** are correlated by being converted or transformed to use object coordinate system **228** in model **234** of object **206**. This conversion or transformation can be made when the same reference points are used for the origin of object **206**. For example, when object **206** is an aircraft, this origin can be determined, for example, by using three or more reference points. The origin can be, for example, a nose tip, a wingtip, a window, or some other feature on or within the aircraft.

As depicted, augmented reality device **212** is configured to receive current physical anchor position **220** of active portable anchor **214** relative to object **206** from active portable anchor **214**. Augmented reality device **212** is configured to determine current model anchor position **232** of active portable anchor **214** using current physical anchor position **220** in model **234** of object **206**. For example, augmented reality device **212** determines current model anchor position **232** of active portable anchor **214** in model **234** of object **206** that correlates to current physical anchor position **220** of active portable anchor **214** relative to object **206** received from active portable anchor **214**.

In this illustrative example, model **234** of object **206** can take a number of different forms. For example, model **234** can be a partial model of object **206** that contains a portion of object **206** or can contain all of object **206**. For example, when object **206** is an aircraft, model **234** can be a wing of the aircraft or the entire aircraft. In one illustrative example, the partial model of object **206** is selected from at least one of the portion of object **206** in a field of view of augmented reality device **212** or the portion of object **206** within a selected distance of augmented reality device **212**.

In still another illustrative example, model **234** of object **206** may be selected from one of a plurality of partial models that are based on dividing object **206** into regions based on various criteria. The criteria may include, for example, at least one of, a type of operation to be performed on object **206**, size limitations for the partial models, storage space available in augmented reality device **212** for a partial model, and other suitable types of criteria.

Augmented reality device **212** is configured to display augmented reality information **208** in association on live view **204** of object **206** in augmented reality device **212** using current model anchor position **232** of active portable anchor **214** and model **234** of object **206**. As a result, current model anchor position **232** of active portable anchor **214** in model **234** of object **206** is dynamically updated to reflect current physical anchor position **220** of active portable anchor **214** relative to object **206**.

In this illustrative example, computer system **236** is in communication with augmented reality device **212**. Computer system **236** sends model **234** of object

206 to augmented reality device **212** in this illustrative example. Computer system **236** is a physical hardware system and includes one or more data processing systems. When more than one data processing system is present, those data processing systems are in communication with each other using a communications medium. The communications medium may be a network. The data processing systems may be selected from at least one of a computer, a server computer, a tablet, or some other suitable data processing system.

In one illustrative example, one or more technical solutions are present that overcome a technical problem with orienting an augmented reality device to an object in a real-world environment. As a result, one or more technical solutions may provide a technical effect of enabling an augmented reality device to orient itself with an anchor. One or more technical solutions provide an active portable anchor in which this anchor can be moved to different locations enabling maintaining a desired distance between augmented reality device **212** and active portable anchor **214**, which results in maintaining a desired level of accuracy in displaying augmented reality information **208** on live view **204**.

As a result, augmented reality system **202** operates as a special purpose computer system in which active portable anchor **214** in augmented reality system **202** enables augmented reality device **212** to display augmented reality information **208** on live view **204** of object **206** with increased accuracy. For example, active portable anchor **214** is a physical component that transforms augmented reality system **202** into a special purpose computer system as compared to currently available general computer systems that do not have active portable anchor **214**.

Turning next to **Figure 3**, an illustration of a block diagram of an active portable anchor is depicted in accordance with an illustrative embodiment. In the illustrative examples, the same reference numeral may be used in more than one figure. This reuse of a reference numeral in different figures represents the same element in the different figures.

This figure depicts one manner in which active portable anchor **214** can be implemented. In this example, active portable anchor **214** comprises portable frame

300, communications unit **302**, output system **304**, and processor unit **306**. In this example, these components enable active portable anchor **214** to be used by an augmented reality device to display augmented reality information on a live view of an object. These components operate to enable active portable anchor **214** to output a current physical anchor position of active portable anchor **214** relative to an object.

As depicted, portable frame **300** is a structure that operates to support, enclose, or hold components for active portable anchor **214**. At least one of dimensions or weight of portable frame **300** is selected such that portable frame **300** can be moved by a human operator. In some cases, the dimensions or weight can be selected such that two human operators may move portable frame **300**.

Portable frame **300** can take a number of different forms. For example, portable frame **300** can be a housing, an enclosure, a platform, or some other suitable structure. In this example, communications unit **302**, output system **304**, and processor unit **306** can be physically connected to portable frame **300**.

As used herein, a first component “physically connected to” a second component means that the first component can be connected directly or indirectly to the second component. In other words, additional components may be present between the first component and the second component. The first component is considered to be indirectly connected to the second component when one or more additional components are present between the two components. When the first component is directly connected to the second component, no additional components are present between the two components.

As depicted, communications unit **302** can be implemented using Wi-Fi, Bluetooth, or some other wireless transmission technology using radio frequency waves, optical signals, or other types of wireless transmission media. For example, “Wi-Fi” is a trademark of the Wi-Fi alliance, and “Bluetooth” is a registered trademark of Bluetooth SIG, Inc.

In this illustrative example, communications unit **302** is configured to receive physical anchor position **222** of active portable anchor **214** and physical object

position **224** of object **206** as determined by external tracking system **216**. This position information can be received using a wireless communications link established by communications unit **302**.

Output system **304** is physically connected to portable frame **300**. The output from output system **304** and active portable anchor **214** can be made using at least one of a wireless transmitter or a display device.

In this example, processor unit **306** is physically connected to portable frame **300** and in communication with communications unit **302** and output system **304**. Processor unit **306** is configured to determine the current physical anchor position of the active portable anchor relative to a physical object position of an object using the physical anchor position and the physical object position; and output the current physical anchor position of the active portable anchor relative to the physical object position of the object using the output system.

The illustration of augmented reality environment **200** and the different components in **Figure 2** and **Figure 3** are not meant to imply physical or architectural limitations to the manner in which an illustrative embodiment may be implemented. Other components in addition to or in place of the ones illustrated may be used. Some components may be unnecessary. Also, the blocks are presented to illustrate some functional components. One or more of these blocks may be combined, divided, or combined and divided into different blocks when implemented in an illustrative embodiment.

Turning next to **Figure 4**, an illustration of a dataflow diagram for displaying augmented reality information on a live view of an object is depicted in accordance with an illustrative embodiment. As depicted, data flow for displaying augmented reality information on a live view of object **400** is depicted in accordance with an illustrative embodiment. In this illustrative example, smart glasses **402** are example of an implementation for augmented reality device **212** in **Figure 2**. Smart glasses **402** receives model **404** of object **400** from computer **405**. Model **404** is used by smart glasses **402** to display augmented reality information on the live view of object **400**. As depicted, graphics, information, and other data from model **404** can be

used to create augmented reality information or be displayed as augmented reality information.

In positioning augmented reality information **418** on the live view of object **400**, smart glasses **402** orients itself with respect to active portable anchor **406**. In this example, the orientation is performed by recognizing active portable anchor **406** as a reference for use in identifying the position of smart glasses **402** and correlating model **404** of object **400** with the live view of object **400**. This recognition can be made when active portable anchor **406** is in the field of view of smart glasses **402**.

Smart glasses **402** use photogrammetry sensors and processes to identify active portable anchor **406**. This identification can be based on at least one of shape, dimensions, or other visual characteristics of active portable anchor **406**. In this illustrative example, active portable anchor **406** also provides its position to smart glasses **402**. The position of active portable anchor **406** is received from active portable anchor **406** in current position data **414** and used to display augmented reality information **418** on the live view of active portable anchor **406**.

In this illustrative example, active portable anchor **406** is moveable during the operation of smart glasses **402**. The current position of active portable anchor **406** can be determined dynamically using external tracking system **408**.

In this illustrative example, external tracking system **408** includes positioner **410** and object positioner probe **411**. Object positioner probe **411** may be manipulated by at least one of a human user or a robot to touch different points on object **400**. Positioner **410** records measurements based on object positioner probe **411** touching object **400**. Object positioner probe **411** also can be used make measurements of active portable anchor **406**. These measurements may be used to identify a physical anchor position for active portable anchor **406** and a physical object position for object **400** that form position information **412**.

Position information **412** is sent to active portable anchor **406**. Active portable anchor **406** generates current position data **414** using position information **412**. Current position data **414** includes a current physical anchor position of active

portable anchor **406** relative to object **400**. Active portable anchor **406** sends current position data **414** to smart glasses **402**.

As depicted, smart glasses **402** identify the current physical anchor position of active portable anchor **406** relative to object **400** in current position data **414**. The position of active portable anchor **406** in model **404** is updated such that the current model anchor position for active portable anchor **406** corresponds to the current physical anchor position for active portable anchor **406** relative to object **400**.

Smart glasses **402** orients itself with respect to object **400** using active portable anchor **406**. With this orientation, smart glasses **402** identify the position of smart glasses **402** relative to active portable anchor **406**.

Smart glasses **402** display augmented reality information **418** on the live view of object **400**. The positioning of augmented reality information **418** on the live view can be performed with greater accuracy when active portable anchor **406** is within a desired distance of smart glasses **402**. If smart glasses **402** move, active portable anchor **406** can also be moved.

If active portable anchor **406** is moved, updates to the position in model **404** can be performed dynamically using external tracking system **408** to identify the position of active portable anchor **406** and send updated position information to active portable anchor **406**.

With reference to **Figure 5**, an illustration of an augmented reality environment is depicted in accordance with an illustrative embodiment. Augmented reality environment **501** is an example of one implementation for augmented reality environment **200** shown in block form in **Figure 2**.

In this illustrative example, aircraft **500** is an example of object **206** in **Figure 2**. Further, active portable anchor **502** is positioned relative to aircraft **500**. As depicted, external tracking system **504** identifies the position of aircraft **500** and active portable anchor **502**. External tracking system **504** comprises intelligent global positioning system (iGPS) locator **506**, intelligent global positioning system (iGPS) locator **508**, and intelligent global positioning system (iGPS) locator **510**.

These intelligent global positioning system locators include laser transmitters that scan a volume of space encompassing aircraft **500** and active portable anchor **502** from different locations to identify positions of these two objects. The positions include locations and orientations based on the coordinate system for external tracking system **504**.

In this depicted example, nose tip **512** of aircraft **500** is selected as a reference point for aircraft **500**. As depicted, nose tip **512** has a position that includes location $L1(100,200,50)$ and an orientation described as X-Vector $X1(0.7,0.7,0.14)$ and Z-Vector $Z1(-0.19, 0.28, 0.98)$. Top **514** of active portable anchor **502** is selected as a reference point for active portable anchor **502** and has a position that includes location $L2(60,80,10)$ and an orientation described as X-Vector $X2(0.44,-0.88,0.15)$ and Z-Vector $Z2(0.1, -0.1, 0.99)$.

The location of active portable anchor **502** relative to aircraft **500** can be identified by subtracting the position of nose tip **512** from the position of top **514**. The relative location is identified as $L2-L1 =$ relative location $RL(40,120,40)$. The relative orientation $RL(X'Z')$ is $X'=X2-X1 = (0.26,1.58,-0.01)$ and $Z'=Z2-Z1 = (-0.29,0.38,-0.01)$

Subtracting these positions provides a relative location in three dimensions and a relative orientation for active portable anchor **502** that is relative to aircraft **500**. This position of active portable anchor **502** can be used to update the model anchor position for active portable anchor **502** in a model of aircraft **500**.

In this depicted example, the nose tip in the model corresponding to nose tip **512** is at the origin for the model of the aircraft having a location $LM(0,0,0)$ with an orientation of $XM =$ X-Vector $(1,0,0)$ and $ZM =$ Z-Vector $(0,0,1)$. In this example, the current model anchor position in the model can be updated to reflect the position of the active portable anchor in the real-world environment. For example, the anchor location (AL) in the model is $LM(0,0,0) + RL(40,120,40) = AL(40,120,40)$ and the anchor orientation (AO) is $AO(X',Z')$, wherein $XA = (1,0,0) + (0.26,1.58,-0.01) = (1.26,1.58,-0.01)$ and $ZA = (0,0,1) + (-0.29,0.38,-0.01) = (-0.29,0.38,0.99)$.

With reference next to **Figure 6**, an illustration of an active portable anchor is depicted in accordance with an illustrative embodiment. In this illustrative example, active portable anchor **600** is an example of one implementation for active portable anchor **214** shown in block form in **Figure 2** and **Figure 3**.

As depicted, active portable anchor **600** has portable frame **606**. Flat plate **608** is physically connected to portable frame **606**. Flat plate **608** has a shape that an augmented reality device will recognize as an anchor for use in orienting itself.

Display device **604** is physically connected to flat plate **608** and provides an ability to display the position of active portable anchor **600**. Display device **604** can display, for example, a barcode, a matrix barcode, or some other suitable type of format that visually conveys the position of active portable anchor **600**. Antennas **610** are configured to receive position information from an external tracking system.

The different processes in the flowcharts in **Figures 7-9** can be implemented in hardware, software, or both. When implemented in software, the processes can take the form of program code that is run by one or more processor units located in one or more hardware devices in one or more computer systems.

With reference to **Figure 7**, an illustration of a flowchart of a process for displaying augmented reality information on a live view is depicted in accordance with an illustrative embodiment. In this depicted example, the process in **Figure 7** can be implemented in one or more components in augmented reality system **202** in **Figure 2**. For example, the different operations can be implemented by processor system **218**, which contains processors that can be located in the different hardware components in augmented reality system **202** and augmented reality device **212** in **Figure 2**.

The process begins by an external tracking system determining a physical anchor position of an active portable anchor and a physical object position of an object (operation **700**). In this illustrative example, operation **700** can be performed by one or more processor units in external tracking system **216** in **Figure 2**. These two positions, the physical anchor position and the physical object position, are in a tracking coordinate system for the external tracking system.

A processor system generates current position data (operation **702**). The current position data contains the current physical anchor position of the active portable anchor relative to the object. This current physical anchor position can be identified by subtracting the physical object position from the physical anchor position. Operation **702** can be performed by one or more processor units in the processor system located in at least one of the external tracking system and the active portable anchor.

The active portable anchor outputs the current position data (operation **704**). In the illustrative example, the output can be in a form selected from at least one of a wireless transmission or a visual display of the current position data.

The processor system updates a model of the object with the current position data (operation **706**). In operation **704**, the process updates the model to reflect a current model anchor position for the active portable anchor relative to the object in the model.

In this example, one or more processor units in the processor system perform this operation and can be located in at least one of the augmented reality device or a computer that stores or sends the model of the object to the augmented reality device, or on some other data processing and the augmented reality system.

In operation **706**, the position of the active physical anchor in the model of the object is updated to reflect the current position of the active portable anchor in the real-world environment.

An augmented reality device orients itself with the active portable anchor in a real-world environment (operation **708**). The process terminates thereafter. In this illustrative example, the augmented reality device receives and uses the current physical anchor position output by the active portable anchor to correspond the model of the object on a live view of the object in the real-world environment. The augmented reality device displays augmented reality information with increased accuracy as compared to currently used.

With reference next to **Figure 8**, an illustration of a flowchart of a process for outputting a current physical anchor position to orient an augmented reality device is

depicted in accordance with an illustrative embodiment. The process depicted in this flowchart can be implemented in active portable anchor **214** in **Figure 2**.

The process begins by identifying a current physical anchor position of an active portable anchor (operation **800**). The active portable anchor is used by an augmented reality device to display augmented reality information on a live view of an object.

In one illustrative example, the identification performed in operation **800** comprises determining, by the active portable anchor, the current physical anchor position of the active portable anchor relative to the object using a physical anchor position of the active portable anchor and a physical object position of the object. In another example, the identifying step comprises determining, by the active portable anchor, the current model anchor position of the active portable anchor in the model of the object that correlates to the current physical anchor position of the active portable anchor relative to the object received from the active portable anchor. In still another illustrative example, the identifying step comprises determining, by an external tracker, the current physical anchor position of the active portable anchor relative to the object using a physical anchor position of the active portable anchor and a physical object position of the object.

The process outputs the current physical anchor position of the active portable anchor relative to an object (operation **802**). The process terminates thereafter. This current physical anchor position can be dynamically updated when the active portable anchor is moved to maintain a desired distance from an augmented reality device.

Turning next to **Figure 9**, an illustration of a flowchart of a process for displaying augmented reality information is depicted in accordance with an illustrative embodiment. The process in **Figure 9** can be implemented in augmented reality device **212** in **Figure 2**.

The process begins by receiving a current physical anchor position of an active portable anchor relative to an object from the active portable anchor (operation **900**). The process determines a current model position of the active portable anchor in a

model of the object using the current physical anchor position of the active portable anchor relative to the object (operation **902**). The process updates the model with the current model position of the active portable anchor (operation **904**).

The process displays augmented reality information on a live view of the object in an augmented reality device using the current model position of the active portable anchor and the model of the object (operation **906**). The process terminates thereafter.

Accuracy in positioning augmented reality information on a live view of the object is increased with dynamically updating the current position of the active portable anchor in the model of the object to reflect the current physical anchor position of the active portable anchor relative to the physical object position of the object.

With reference next to **Figure 10**, an illustration of a flowchart of a process for orienting an augmented reality device is depicted in accordance with an illustrative embodiment. The process in **Figure 10** can be implemented in one or more components in augmented reality system **202**. For example, the different operations can be implemented by one or more processor units in augmented reality device **212** in **Figure 2**.

The process begins by obtaining a current physical anchor position of an active portable anchor from the active portable anchor (operation **1000**). In operation **1000**, the current physical anchor position can be displayed on a display device on the active portable anchor. The current physical anchor position can be obtained by the augmented reality device from the display device. In another illustrative example, the current physical anchor position can be obtained by the augmented reality device from a wireless transmission received by the augmented reality device from the active portable anchor.

The process sets a local coordinate system for the augmented reality device based on the current physical anchor position of the active portable anchor (operation **1002**). This position includes a location in three-dimensional space and an orientation.

The process identifies a current model anchor position of the active portable anchor in a model of an object (operation **1004**). This current model anchor position is in the coordinate system used by the model. The process loads and repositions geometries in the model for display to match the local coordinate system (operation **1006**). The process terminates thereafter. In operation **1006**, the augmented reality device loads augmented reality information from the model for display on a live view of the object with the desired position on the live view.

With reference next to **Figure 11**, an illustration of a flowchart of a process for receiving a current physical anchor position is depicted in accordance with an illustrative embodiment. The process in **Figure 11** can be implemented in augmented reality device **212** in **Figure 2**.

The process begins by identifying more than one active portable anchors in a group of active portable anchors for an object (operation **1100**). In this example, the group of active portable anchors is a plurality of active portable anchors for the object. The process selects a number of active portable anchors from the group of active portable anchors (operation **1102**). As used herein, a “number of,” when used with reference to items, means one or more items. For example, a number of active portable anchors is one or more active portable anchors.

The selection in operation **1102** can be made a number of different ways. For example, the selection of the closest active portable anchor can be based on the closest one in a field of view of an augmented reality device. In another example, more than one active portable anchors are used in a calibration and location is cross referenced using more than one anchor origin. A bias or heavier weighting can be given to the closer anchor.

The process receives a selected number of current physical anchor positions from a selected number of current active portable anchors in the plurality of active portable anchors (operation **1104**). The process terminates thereafter. For example, the augmented reality device can receive a single current anchor position of the closest active portable anchor. In yet another illustrative example, the augmented reality

device receives a selected plurality of current physical anchor positions from a plurality of current active portable anchors.

The flowcharts and block diagrams in the different depicted embodiments illustrate the architecture, functionality, and operation of some possible implementations of apparatuses and methods in an illustrative embodiment. In this regard, each block in the flowcharts or block diagrams can represent at least one of a module, a segment, a function, or a portion of an operation or step. For example, one or more of the blocks can be implemented as program code, hardware, or a combination of the program code and hardware. When implemented in hardware, the hardware may, for example, take the form of integrated circuits that are manufactured or configured to perform one or more operations in the flowcharts or block diagrams. When implemented as a combination of program code and hardware, the implementation may take the form of firmware. Each block in the flowcharts or the block diagrams may be implemented using special purpose hardware systems that perform the different operations or combinations of special purpose hardware and program code run by the special purpose hardware.

In some alternative implementations of an illustrative embodiment, the function or functions noted in the blocks may occur out of the order noted in the figures. For example, in some cases, two blocks shown in succession may be performed substantially concurrently, or the blocks may sometimes be performed in the reverse order, depending upon the functionality involved. Also, other blocks may be added in addition to the illustrated blocks in a flowchart or block diagram.

Turning now to **Figure 12**, an illustration of a block diagram of a data processing system is depicted in accordance with an illustrative embodiment. Data processing system **1200** may be used to implement server computer **104**, server computer **106**, client devices **110**, augmented reality device **212**, active portable anchor **214**, external tracking system **216**, computer system **236**, smart glasses **402**, computer **405**, active portable anchor **406**, and any other data processing system that may be used to perform operations on the different illustrative examples. As depicted, data processing system **1200** includes communications framework **1202**, which provides

communications between processor unit **1204**, memory **1206**, persistent storage **1208**, communications unit **1210**, input/output (I/O) unit **1212**, and display **1214**. In this example, communications framework **1202** may take the form of a bus system. Processor unit **1204** serves to execute instructions for software that may be loaded into memory **1206**. Processor unit **1204** may be a number of processors, a multi-processor core, or some other type of processor, depending on the particular implementation.

Memory **1206** and persistent storage **1208** are examples of storage devices **1216**. A storage device is any piece of hardware that is capable of storing information, such as, for example, without limitation, at least one of data, program code in functional form, or other suitable information either on a temporary basis, a permanent basis, or both on a temporary basis and a permanent basis. Storage devices **1216** may also be referred to as computer-readable storage devices in these illustrative examples. Memory **1206**, in these examples, may be, for example, a random-access memory or any other suitable volatile or non-volatile storage device. Persistent storage **1208** may take various forms, depending on the particular implementation.

For example, persistent storage **1208** may contain one or more components or devices. For example, persistent storage **1208** may be a hard drive, a solid-state drive (SSD), a flash memory, a rewritable optical disk, a rewritable magnetic tape, or some combination of the above. The media used by persistent storage **1208** also may be removable. For example, a removable hard drive may be used for persistent storage **1208**.

Communications unit **1210**, in these illustrative examples, provides for communications with other data processing systems or devices. In these illustrative examples, communications unit **1210** is a network interface card.

Input/output unit **1212** allows for input and output of data with other devices that may be connected to data processing system **1200**. For example, input/output unit **1212** may provide a connection for user input through at least one of a keyboard, a mouse, or some other suitable input device. Further, input/output unit **1212** may

send output to a printer. Display **1214** provides a mechanism to display information to a user.

Instructions for at least one of the operating system, applications, or programs may be located in storage devices **1216**, which are in communication with processor unit **1204** through communications framework **1202**. The processes of the different embodiments may be performed by processor unit **1204** using computer-implemented instructions, which may be located in a memory, such as memory **1206**.

These instructions are referred to as program code, computer usable program code, or computer-readable program code that may be read and executed by a processor in processor unit **1204**. The program code in the different embodiments may be embodied on different physical or computer-readable storage media, such as memory **1206** or persistent storage **1208**.

Program code **1218** is located in a functional form on computer-readable media **1220** that is selectively removable and may be loaded onto or transferred to data processing system **1200** for execution by processor unit **1204**. Program code **1218** and computer-readable media **1220** form computer program product **1222** in these illustrative examples. In the illustrative example, computer-readable media **1220** is computer-readable storage media **1224**.

In these illustrative examples, computer-readable storage media **1224** is a physical or tangible storage device used to store program code **1218** rather than a medium that propagates or transmits program code **1218**.

Alternatively, program code **1218** may be transferred to data processing system **1200** using a computer-readable signal media. The computer-readable signal media may be, for example, a propagated data signal containing program code **1218**. For example, the computer-readable signal media may be at least one of an electromagnetic signal, an optical signal, or any other suitable type of signal. These signals may be transmitted over at least one of communications links, such as wireless communications links, optical fiber cable, coaxial cable, a wire, or any other suitable type of communications link.

The different components illustrated for data processing system **1200** are not meant to provide architectural limitations to the manner in which different embodiments may be implemented. The different illustrative embodiments may be implemented in a data processing system including components in addition to or in place of those illustrated for data processing system **1200**. Other components shown in **Figure 12** can be varied from the illustrative examples shown. The different embodiments may be implemented using any hardware device or system capable of running program code **1218**.

Illustrative embodiments of the disclosure may be described in the context of aircraft manufacturing and service method **1300** as shown in **Figure 13** and aircraft **1400** as shown in **Figure 14**. Turning first to **Figure 13**, an illustration of a block diagram of an aircraft manufacturing and service method is depicted in accordance with an illustrative embodiment. During pre-production, aircraft manufacturing and service method **1300** may include specification and design **1302** of aircraft **1400** in **Figure 14** and material procurement **1304**.

During production, component and subassembly manufacturing **1306** and system integration **1308** of aircraft **1400** in **Figure 14** takes place. Thereafter, aircraft **1400** in **Figure 14** may go through certification and delivery **1310** in order to be placed in service **1312**. While in service **1312** by a customer, aircraft **1400** in **Figure 14** is scheduled for routine maintenance and service **1314**, which may include modification, reconfiguration, refurbishment, and other maintenance or service. For example, aircraft inspections during routine maintenance and service **1314** can include operations to maintain or increase at least one of safety of flight or availability of aircraft **1400** in **Figure 14**.

Each of the processes of aircraft manufacturing and service method **1300** may be performed or carried out by a system integrator, a third party, an operator, or some combination thereof. In these examples, the operator may be a customer. For the purposes of this description, a system integrator may include, without limitation, any number of aircraft manufacturers and major-system subcontractors; a third party may include, without limitation, any number of vendors, subcontractors, and

suppliers; and an operator may be an airline, a leasing company, a military entity, a service organization, and so on.

With reference now to **Figure 14**, an illustration of an aircraft is depicted in which an illustrative embodiment may be implemented. In this example, aircraft **1400** is produced by aircraft manufacturing and service method **1300** in **Figure 13** and may include airframe **1402** with plurality of systems **1404** and interior **1406**. Examples of systems **1404** include one or more of propulsion system **1408**, electrical system **1410**, hydraulic system **1412**, and environmental system **1414**. Any number of other systems may be included. Although an aerospace example is shown, different illustrative embodiments may be applied to other industries, such as the automotive industry.

Apparatuses and methods embodied herein may be employed during at least one of the stages of aircraft manufacturing and service method **1300** in **Figure 13**.

In one illustrative example, components or subassemblies produced in component and subassembly manufacturing **1306** in **Figure 13** may be fabricated or manufactured in a manner similar to components or subassemblies produced while aircraft **1400** is in service **1312** in **Figure 13**. As yet another example, one or more apparatus embodiments, method embodiments, or a combination thereof may be utilized during production stages, such as component and subassembly manufacturing **1306** and system integration **1308** in **Figure 13**. One or more apparatus embodiments, method embodiments, or a combination thereof may be utilized while aircraft **1400** is in service **1312**, during maintenance and service **1314** in **Figure 13**, or both. For example, augmented reality system **202** in **Figure 2** can be utilized during at least one of component and subassembly manufacturing **1306**, system integration **1308**, certification and delivery **1310**, in service **1312**, or maintenance and service **1314**. With the use of active portable anchor **214**, the display of augmented reality information on a live view to human operator may be performed in a manner that allows the human operator to move more freely and maintain a desired level of accuracy in displaying augmented reality information as compared to currently available techniques. A number of the different illustrative

embodiments may substantially expedite the assembly of aircraft **1400**, reduce the cost of aircraft **1400**, or both expedite the assembly of aircraft **1400** and reduce the cost of aircraft **1400**.

Turning now to **Figure 15**, an illustration of a block diagram of a product management system is depicted in accordance with an illustrative embodiment. Product management system **1500** is a physical hardware system. In this illustrative example, product management system **1500** may include at least one of manufacturing system **1502** or maintenance system **1504**.

Manufacturing system **1502** is configured to manufacture products, such as aircraft **1400** in **Figure 14**. As depicted, manufacturing system **1502** includes manufacturing equipment **1506**. Manufacturing equipment **1506** includes at least one of fabrication equipment **1508** or assembly equipment **1510**.

Fabrication equipment **1508** is equipment that may be used to fabricate components for parts used to form aircraft **1400** in **Figure 14**. For example, fabrication equipment **1508** may include machines and tools. These machines and tools may be at least one of a drill, a hydraulic press, a furnace, a mold, a composite tape laying machine, a vacuum system, a lathe, or other suitable types of equipment. Fabrication equipment **1508** may be used to fabricate at least one of metal parts, composite parts, semiconductors, circuits, fasteners, ribs, skin panels, spars, antennas, or other suitable types of parts.

Assembly equipment **1510** is equipment used to assemble parts to form aircraft **1400** in **Figure 14**. In particular, assembly equipment **1510** may be used to assemble components and parts to form aircraft **1400**. Assembly equipment **1510** also may include machines and tools. These machines and tools may be at least one of a robotic arm, a crawler, a faster installation system, a rail-based drilling system, or a robot. Assembly equipment **1510** may be used to assemble parts such as seats, horizontal stabilizers, wings, engines, engine housings, landing gear systems, and other parts for aircraft **1400**.

In this illustrative example, maintenance system **1504** includes maintenance equipment **1512**. Maintenance equipment **1512** may include any equipment needed

to perform maintenance on aircraft **1400** in **Figure 14**. Maintenance equipment **1512** may include tools for performing different operations on parts on aircraft **1400**. These operations may include at least one of disassembling parts, refurbishing parts, inspecting parts, reworking parts, manufacturing replacement parts, or other operations for performing maintenance on aircraft **1400**. These operations may be for routine maintenance, inspections, upgrades, refurbishment, or other types of maintenance operations.

In the illustrative example, maintenance equipment **1512** may include ultrasonic inspection devices, x-ray imaging systems, vision systems, drills, crawlers, and other suitable devices. In some cases, maintenance equipment **1512** may include fabrication equipment **1508**, assembly equipment **1510**, or both to produce and assemble parts that may be needed for maintenance.

Product management system **1500** also includes control system **1514**. Control system **1514** is a hardware system and may also include software or other types of components. Control system **1514** is configured to control the operation of at least one of manufacturing system **1502** or maintenance system **1504**. In particular, control system **1514** may control the operation of at least one of fabrication equipment **1508**, assembly equipment **1510**, or maintenance equipment **1512**.

The hardware in control system **1514** may include computers, circuits, networks, and other types of equipment. The control may take the form of direct control of manufacturing equipment **1506**. For example, robots, computer-controlled machines, and other equipment may be controlled by control system **1514**. In other illustrative examples, control system **1514** may manage operations performed by human operators **1516** in manufacturing or performing maintenance on aircraft **1400**. For example, control system **1514** may assign tasks, provide instructions, display models, or perform other operations to manage operations performed by human operators **1516**. In these illustrative examples, augmented reality system **202** in **Figure 2** may be implemented in control system **1514** to manage at least one of the manufacturing or maintenance of aircraft **1400** in **Figure 14**.

For example, augmented reality system **202** in **Figure 2** operates to display augmented reality information to human operators performing at least one of manufacturing or maintenance of a product such as aircraft **1400** in **Figure 14**. The augmented reality information may present instructions to perform at least one of manufacturing or maintenance operations. As another example, the augmented reality information may identify work orders or tasks to be performed at different locations on aircraft **1400**. Further, the augmented reality information displayed may guide human operators to positions on aircraft **1400** where operations should be performed.

Further, augmented reality system **202** in **Figure 2** can also be used to receive input from human operators. For example, the human operators may record inconsistencies identified from visual inspections using augmented reality system **202**.

In the different illustrative examples, human operators **1516** may operate or interact with at least one of manufacturing equipment **1506**, maintenance equipment **1512**, or control system **1514**. This interaction may be performed to manufacture aircraft **1400** in **Figure 14**.

Of course, product management system **1500** may be configured to manage other products other than aircraft **1400** in **Figure 14**. Although product management system **1500** has been described with respect to manufacturing in the aerospace industry, product management system **1500** may be configured to manage products for other industries. For example, product management system **1500** can be configured to manufacture products for the automotive industry as well as any other suitable industries.

Thus, one or more illustrative examples utilize active portable anchors that are placed on or proximate an object. These active portable anchors enable augmented reality devices to quickly orient themselves to the object in a real-world environment. Further, the active portable anchors can be used as a calibration plate similar to current anchors. In other words, an augmented reality device can recognize that an anchor is present in the real-world environment and can use this anchor in orienting

itself to display augmented reality information. The active portable anchor also provides an augmented reality device the current anchor position of the active portable anchor relative to the object.

In this manner, in one or more technical solutions, the augmented reality device can locate itself more efficiently through using the active portable anchor and more accurately display augmented reality information in positions with respect to the object. For example, graphical indicators for locations in which holes are to be formed in the object can be displayed as augmented reality information on a live view of the object in a manner that is more accurate than with currently available systems. The active portable anchor can be moved to another position with the active portable anchor being updated to send this new position to the augmented reality device.

As a result, the augmented reality system in the illustrative examples operates as a special purpose computer system in which an active portable anchor in the augmented reality system enables an augmented reality device to display augmented reality information on a live view of an object with increased accuracy. In particular, the active portable anchor is a physical component that transforms the augmented reality system into a special purpose computer system as compared to currently available general computer systems that do not have the active portable anchor.

The illustrative embodiments recognize and take into account that this type of solution can be implemented by utilizing a secondary location system in the form of an external tracking system. The illustrative embodiments recognize and take into account that the external tracking system operates to identify the location of the active portable anchors and relay that information through those active portable anchors, which in turn provide the information to augmented reality devices. Further, accuracy in positioning the augmented reality information on the live view of the object is increased with updating the current model anchor position of the active portable anchor in the model of the object to reflect a change in the current physical

anchor position of the active portable anchor relative to the object from a movement of the active portable anchor.

The description of the different illustrative embodiments has been presented for purposes of illustration and description and is not intended to be exhaustive or limited to the embodiments in the form disclosed. The different illustrative examples describe components that perform actions or operations. In an illustrative embodiment, a component may be configured to perform the action or operation described. For example, the component may have a configuration or design for a structure that provides the component an ability to perform the action or operation that is described in the illustrative examples as being performed by the component. Many modifications and variations will be apparent to those of ordinary skill in the art. Further, different illustrative embodiments may provide different features as compared to other desirable embodiments. The embodiment or embodiments selected are chosen and described in order to best explain the principles of the embodiments, the practical application, and to enable others of ordinary skill in the art to understand the disclosure for various embodiments with various modifications as are suited to the particular use contemplated.

EMBODIMENTS IN WHICH AN EXCLUSIVE PROPERTY OR PRIVILEGE IS CLAIMED ARE DEFINED AS FOLLOWS:

1. An augmented reality system comprising:

an active portable anchor configured to output a current physical anchor position of the active portable anchor relative to an object;

a processor system configured to determine the current physical anchor position of the active portable anchor relative to the object using a physical anchor position of the active portable anchor and a physical object position of the object;

an augmented reality device configured to receive the current physical anchor position of the active portable anchor relative to the object from the active portable anchor; determine a current model anchor position of the active portable anchor in a model of the object using the current physical anchor position; and display augmented reality information in association on a live view of the object in the augmented reality device using the current model anchor position of the active portable anchor and the model of the object, wherein the current model anchor position of the active portable anchor in the model of the object is dynamically updated to reflect the current physical anchor position of the active portable anchor relative to the object.

2. The augmented reality system of claim **1**, wherein the processor system is located in the active portable anchor.

3. The augmented reality system of claim 1 or 2 claim further comprising:

an external tracking system configured to determine the physical anchor position of the active portable anchor and the physical object position of the object in a coordinate system, wherein the processor system is located in the external tracking system.

4. The augmented reality system of any one of claims 1 – 3 further comprising:

a group of active portable anchors for the object, wherein the active portable anchor and the group of active portable anchors are a plurality of active portable anchors for the object and wherein the augmented reality device receives a selected number of current physical anchor positions from a selected number of current active portable anchors in the plurality of active portable anchors.

5. The augmented reality system of any one of claims 1 – 4, wherein the augmented reality device determines the current model anchor position of the active portable anchor in the model of the object that correlates to the current physical anchor position of the active portable anchor relative to the object received from the active portable anchor.

6. The augmented reality system of any one of claims 1 – 5, wherein the model of the object is a partial model of the object that comprises a portion of the object.

7. The augmented reality system of claim 6, wherein the partial model of the object is selected from at least one of the portion of the object in a field of view of the augmented reality device or the portion of the object within a selected distance of the augmented reality device.

8. The augmented reality system of any one of claims **1 – 7**, further comprising:
 - a computer system in communication with the augmented reality device, wherein the computer system sends the model of the object to the augmented reality device.
9. The augmented reality system of any one of claims **1 – 8**, wherein output from the active portable anchor is made using at least one of a wireless transmitter or a display device.
10. The augmented reality system of claim **9**, wherein the output is selected from at least one of a display of the current physical anchor position on the display device or a wireless transmission of the current physical anchor position using the wireless transmitter.
11. The augmented reality system of any one of claims **3 – 10**, wherein the external tracking system includes at least one of a laser tracker, a laser scanner, a camera, a displacement sensor, a measurement sensor, or a probe.
12. The augmented reality system of any one of claims **1 – 11**, wherein the augmented reality information is selected from at least one of a schematic diagram, a user input window, an instruction, a graphic for a hidden structure, or a hologram.
13. The augmented reality system of any one of claims **1 – 12**, wherein the object is selected from a group comprising a mobile platform, a stationary platform, a land-based structure, an aquatic-based structure, a space-based structure, an aircraft, a commercial aircraft, a rotorcraft, a surface ship, a tank, a personnel carrier, a train, a spacecraft, a space station, a satellite, a submarine, an

automobile, a power plant, a bridge, a dam, a house, a manufacturing facility, a building, a fuselage, an engine, a wing, a skin panel, a landing gear assembly, and a monument.

14. An augmented reality system comprising:

an active portable anchor configured to output a current physical anchor position of the active portable anchor relative to an object; and

an external tracking system configured to determine a physical anchor position of the active portable anchor and a physical object position of the object, wherein the current physical anchor position of the active portable anchor relative to the object that is output by the active portable anchor is determined using the physical anchor position of the active portable anchor and the physical object position of the object.

15. The augmented reality system of claim **14** further comprising:

an augmented reality device configured to receive the current physical anchor position of the active portable anchor relative to the object from the active portable anchor; determine a current model anchor position of the active portable anchor using the current physical anchor position of the active portable anchor relative to the object; and display augmented reality information in association on a live view of the object in the augmented reality device using the current model anchor position of the active portable anchor and a model of the object, wherein a model anchor position of the active portable anchor in the model of the object is dynamically updated to reflect the current physical anchor position of the active portable anchor relative to the object enabling increasing an

accuracy in displaying the augmented reality information on the live view of the object.

16. The augmented reality system of any one of claims **14 – 15**, wherein the object is selected from a group comprising a mobile platform, a stationary platform, a land-based structure, an aquatic-based structure, a space-based structure, an aircraft, a commercial aircraft, a rotorcraft, a surface ship, a tank, a personnel carrier, a train, a spacecraft, a space station, a satellite, a submarine, an automobile, a power plant, a bridge, a dam, a house, a manufacturing facility, a building, a fuselage, an engine, a wing, a skin panel, a landing gear assembly, and a monument.
17. The augmented reality system of claim **15**, wherein the model of the object is a partial model of the object that comprises a portion of the object.
18. The augmented reality system of claim **17**, wherein the partial model of the object is selected from at least one of the portion of the object in a field of view of the augmented reality device or the portion of the object within a selected distance of the augmented reality device.
19. An augmented reality system comprising:
 - a network; and
 - a communications port in the network, wherein the communications port is configured to communicate with a portable active anchor and send a current physical anchor position of the active portable anchor relative to an object to the active portable anchor in which the current physical anchor position of the active portable anchor relative to the object is

determined using a physical anchor position of the active portable anchor and a physical object position of the object.

20. The augmented reality system of claim **19**, wherein an augmented reality device is configured to receive the current physical anchor position of the active portable anchor relative to the object from the active portable anchor; determine a current model anchor position of the active portable anchor in a model of the object using the current physical anchor position; and display augmented reality information in association on a live view of the object in the augmented reality device using the current model anchor position of the active portable anchor and the model of the object, wherein the current model anchor position of the active portable anchor in the model of the object is dynamically updated to reflect the current physical anchor position of the active portable anchor relative to the object.

21. An apparatus comprising:

an active portable anchor used by an augmented reality device to display augmented reality information on a live view of an object, wherein the active portable anchor is configured to output a current physical anchor position of the active portable anchor relative to the object.

22. The apparatus of claim **21**, wherein the active portable anchor is configured to receive a physical anchor position of the active portable anchor and a physical object position of the object as determined by an external tracking system; and determine the current physical anchor position of the active portable anchor relative to the object using the physical anchor position of the active portable anchor and the physical object position of the object.

23. The apparatus of claim **22**, wherein the active portable anchor comprises:

a portable frame;

a communications unit physically connected to the portable frame, wherein the communications unit is configured to receive the physical anchor position]of the active portable anchor and the physical object position of the object as determined by the external tracking system;

an output system physically connected to the portable frame; and

a processor unit physically connected to the portable frame and in communication with the communications unit and the output system, wherein the processor unit is configured to determine the current physical anchor position of the active portable anchor relative to the physical object position of the object using the physical anchor position and the physical object position; and output the current physical anchor position of the active portable anchor relative to the physical object position of the object using the output system.

24. The apparatus of claim **23**, wherein the output system comprises at least one of a wireless transmitter or a display device.

25. The apparatus of any one of claims **21** – **24** further comprising:

the augmented reality device configured to receive the current physical anchor position of the active portable anchor relative to the object output by the active portable anchor; and display the augmented reality information on the live view of the object using the current physical anchor position to place the augmented reality information on the live view of the object.

26. The apparatus of claim **25**, wherein the active portable anchor has a shape that is recognized by the augmented reality device as an anchor for displaying the augmented reality information on the live view.

27. The apparatus of claim **25** further comprising:

a group of active portable anchors for the object, wherein the active portable anchor and the group of active portable anchors are a plurality of active portable anchors for the object, and wherein the augmented reality device receives a selected number of current physical anchor positions from a selected number of current active portable anchors in the plurality of active portable anchors.

28. The apparatus of claim **22** further comprising:

an external tracking system configured to determine the physical anchor position of the active portable anchor and the physical object position of the object.

29. The apparatus of claim **28**, wherein the external tracking system is selected from at least one of a laser tracker, a laser scanner, a camera, a displacement sensor, a measurement sensor, or a probe.

30. The apparatus of any one of claims **21** – **29**, wherein the object is selected from a group comprising a mobile platform, a stationary platform, a land-based structure, an aquatic-based structure, a space-based structure, an aircraft, a commercial aircraft, a rotorcraft, a surface ship, a tank, a personnel carrier, a train, a spacecraft, a space station, a satellite, a submarine, an automobile, a power plant, a bridge, a dam, a house, a manufacturing facility, a building, a

fuselage, an engine, a wing, a skin panel, a landing gear assembly, and a monument.

31. An augmented reality system comprising:

an augmented reality device configured to receive a current physical anchor position of an active portable anchor relative to an object from the active portable anchor; determine a current model anchor position of the active portable anchor in a model of the object using the current physical anchor position of the active portable anchor relative to the object; and display augmented reality information on a live view of the object in the augmented reality device using the current model anchor position of the active portable anchor and the model of the object, wherein accuracy in positioning the augmented reality information on the live view of the object is increased with updating the current model anchor position of the active portable anchor in the model of the object to reflect a change in the current physical anchor position of the active portable anchor relative to the object from a movement of the active portable anchor.

32. The augmented reality system of claim **31**, wherein the model of the object is a partial model of the object that comprises a portion of the object.

33. The augmented reality system of claim **32**, wherein the partial model of the object is selected from the portion of the object in a field of view of the augmented reality device and the portion of the object within a selected distance of the augmented reality device.

34. A method for displaying augmented reality information on an augmented reality device, the method comprising:

receiving, by the augmented reality device, a current physical anchor position of an active portable anchor relative to an object from the active portable anchor;

determining, by the augmented reality device, a current model anchor position of the active portable anchor in a model of the object using the current physical anchor position of the active portable anchor relative to the object; and

displaying, by the augmented reality device, the augmented reality information on a live view of the object in the augmented reality device using the current model anchor position of the active portable anchor and the model of the object, wherein accuracy in positioning the augmented reality information on the live view of the object is increased with dynamically updating the current model anchor position of the active portable anchor in the model of the object to reflect the current physical anchor position of the active portable anchor relative to a physical object position of the object.

- 35.** The method of claim **34**, wherein the model of the object is a partial model of the object that comprises a portion of the object.
- 36.** The method of claim **35**, wherein the partial model of the object is selected from the portion of the object in a field of view of the augmented reality device and the portion of the object within a selected distance of the augmented reality device.

37. The method any one of claims **34 – 36** further comprising:

receiving, by the active portable anchor, a physical anchor position of the active portable anchor and the physical object position of the object as determined by an external tracking system;

determining, by the active portable anchor, the current physical anchor position of the active portable anchor relative to the physical object position of the object using the physical anchor position of the active portable anchor and the physical object position of the object ; and

outputting, by the active portable anchor, the current physical anchor position of the active portable anchor relative to the physical object position of the object to the augmented reality device.

38. The method of any one of claims **34 – 37** further comprising:

receiving, by the active portable anchor, the current physical anchor position of the active portable anchor relative to the object.

39. The method of any one of claims **34 – 38**, wherein the current physical anchor position of the active portable anchor relative to the physical object position of the object is output to the augmented reality device by an output system selected from at least one of a wireless transmitter or a display device.

40. The method of any one of claims **34 – 39**, wherein the object is selected from a group comprising a mobile platform, a stationary platform, a land-based structure, an aquatic-based structure, a space-based structure, an aircraft, a commercial aircraft, a rotorcraft, a surface ship, a tank, a personnel carrier, a train, a spacecraft, a space station, a satellite, a submarine, an automobile, a

power plant, a bridge, a dam, a house, a manufacturing facility, a building, a fuselage, an engine, a wing, a skin panel, a landing gear assembly, and a monument.

41. A method for orienting an augmented reality device, the method comprising:

identifying a current physical anchor position of an active portable anchor, wherein the active portable anchor is used by the augmented reality device to display augmented reality information on a live view of an object; and

outputting the current physical anchor position of the active portable anchor relative to the object.

42. The method of claim **41**, wherein the identifying step comprises:

determining, by the active portable anchor, the current physical anchor position of the active portable anchor relative to the object using a physical anchor position of the active portable anchor and a physical object position of the object.

43. The method of any one of claims **41** – **42**, wherein the identifying step comprises:

determining, by the active portable anchor, a current model anchor position of the active portable anchor in a model of the object that correlates to the current physical anchor position of the active portable anchor relative to the object received from the active portable anchor.

44. The method of any one of claims **41 – 43**, wherein the identifying step comprises:

determining, by an external tracker, the current physical anchor position of the active portable anchor relative to the object using a physical anchor position of the active portable anchor and a physical object position of the object.

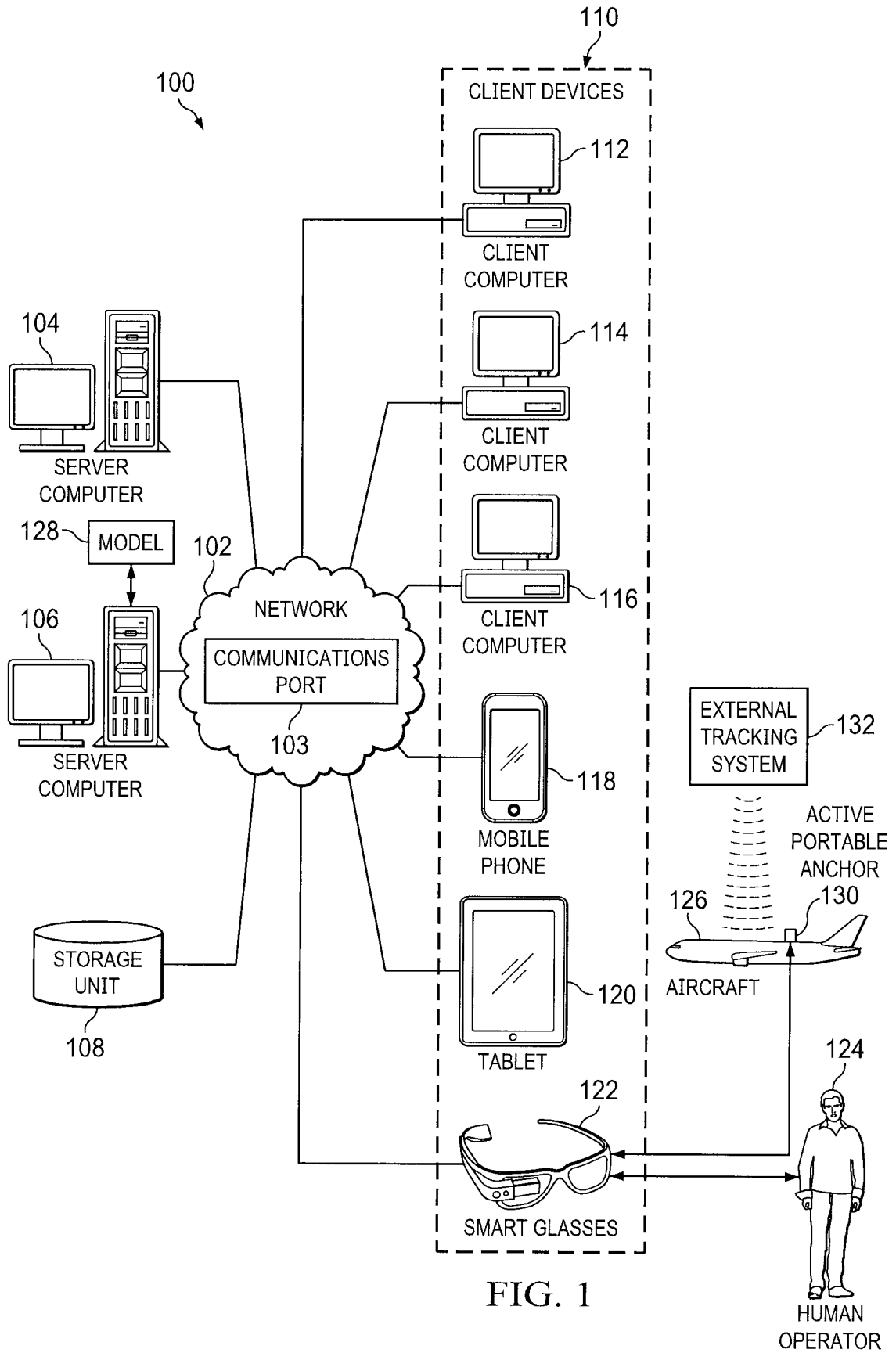

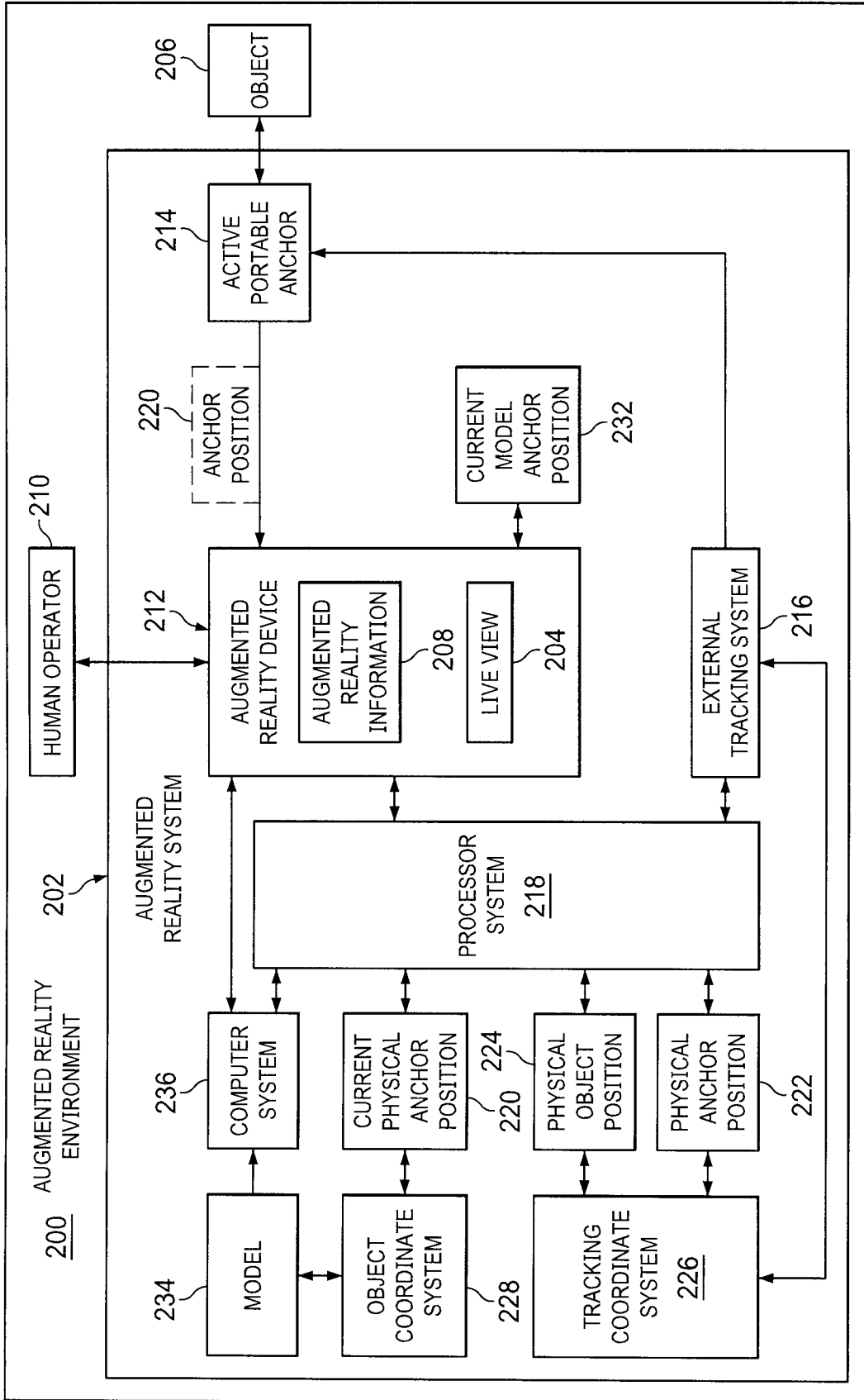

FIG. 2

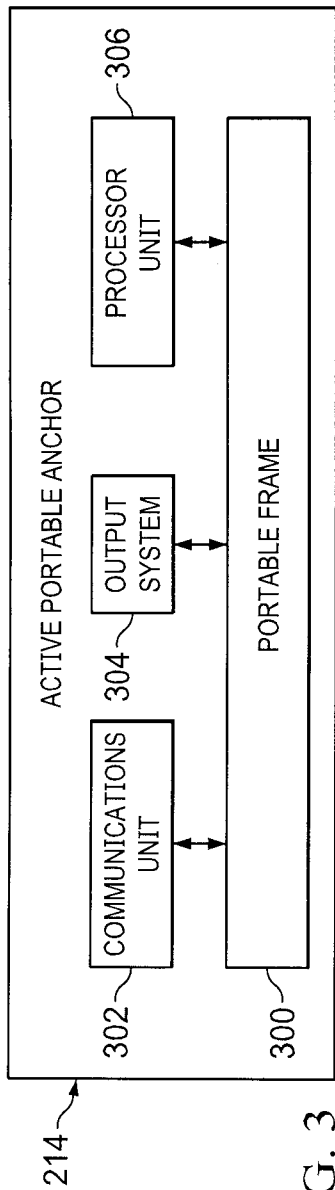

FIG. 3

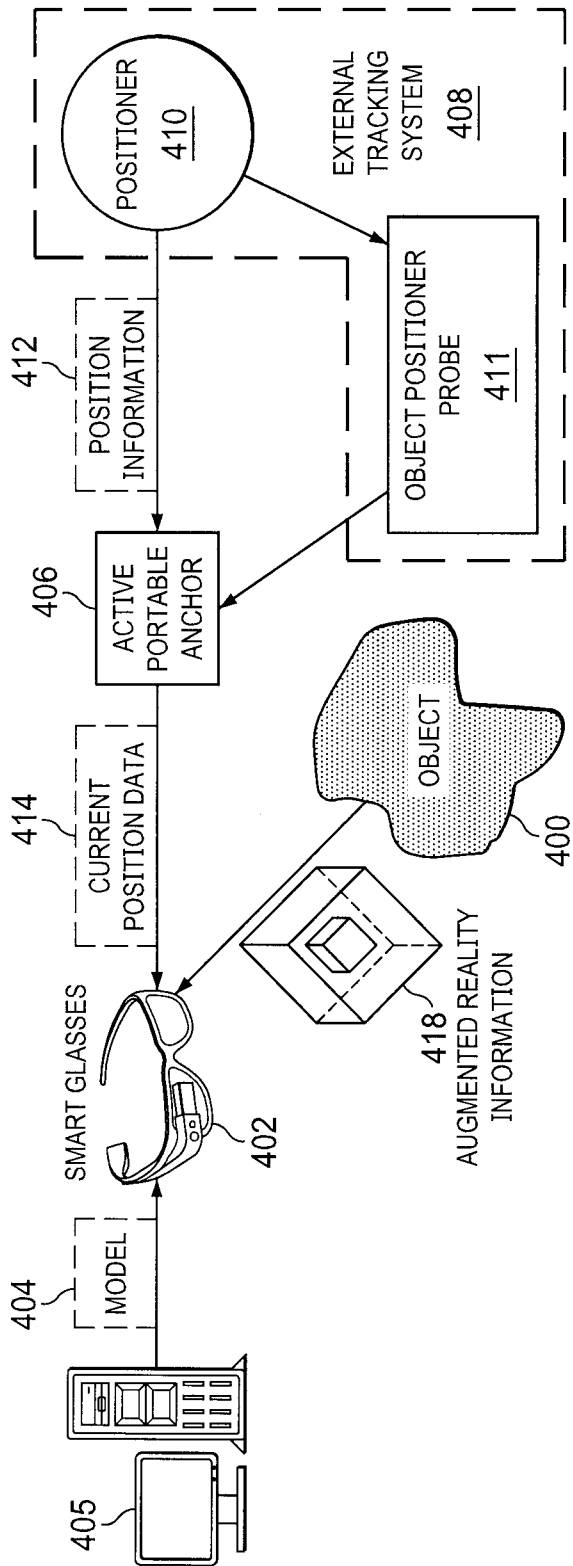

FIG. 4

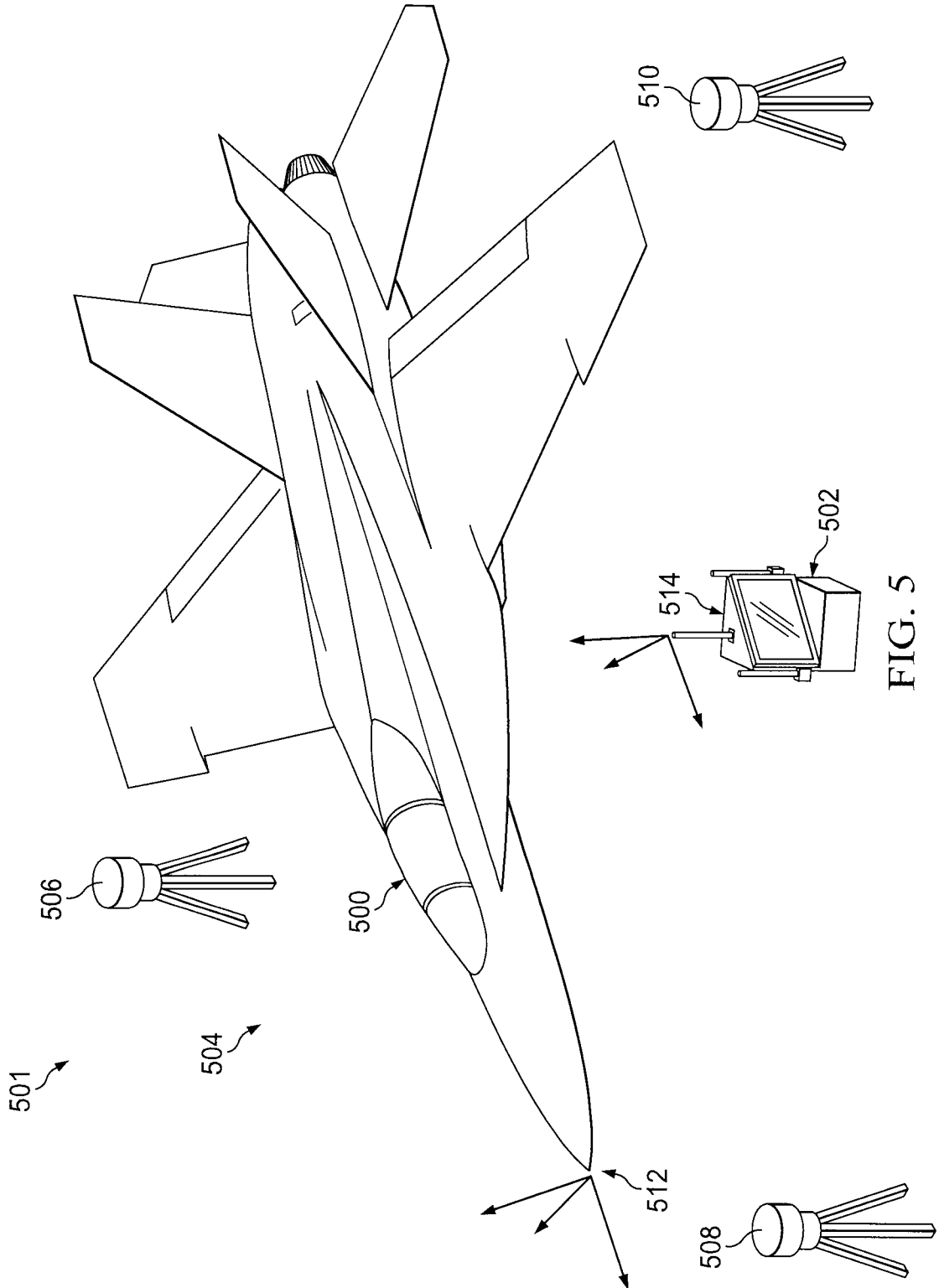

FIG. 5

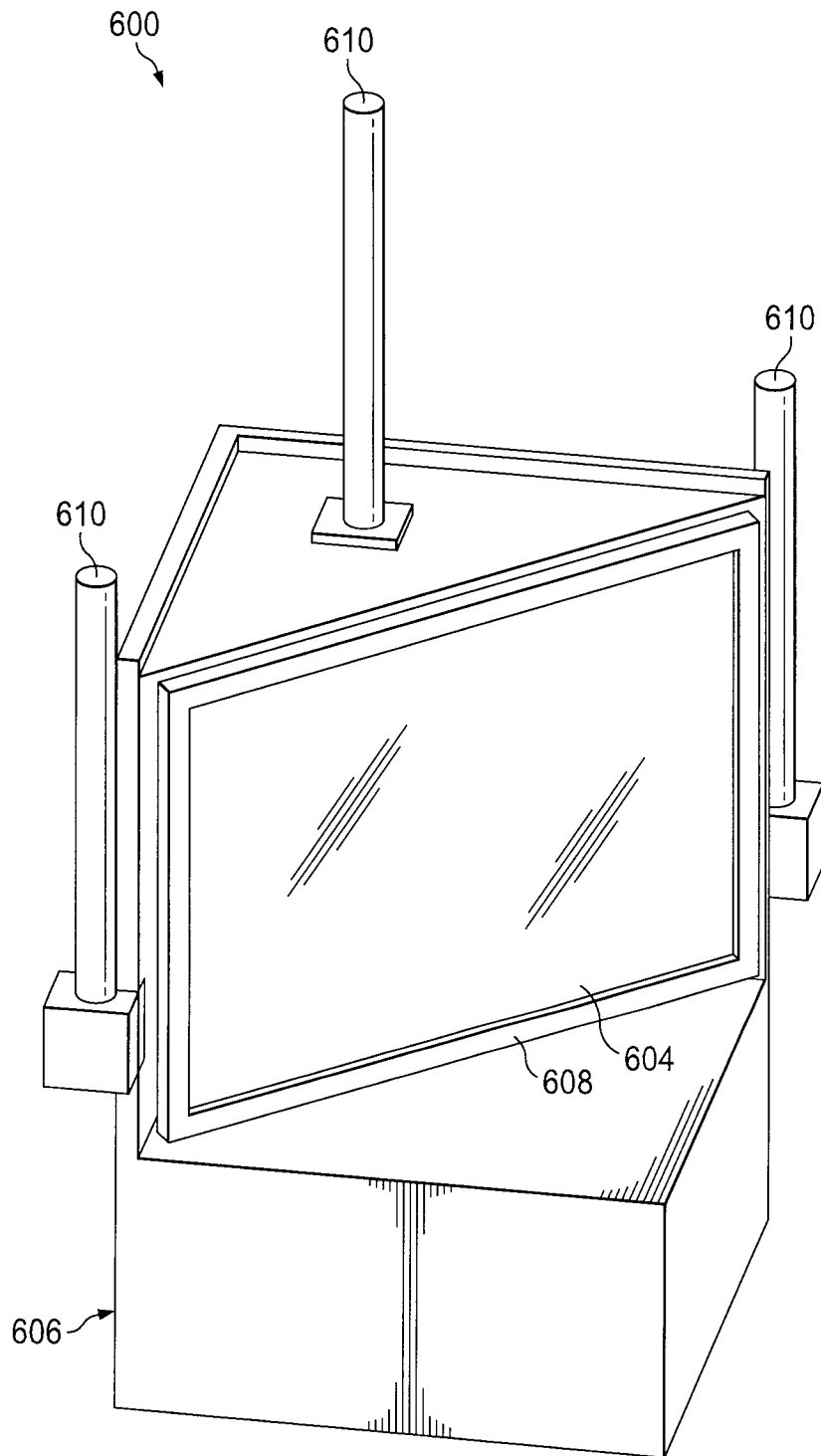

FIG. 6

6/11

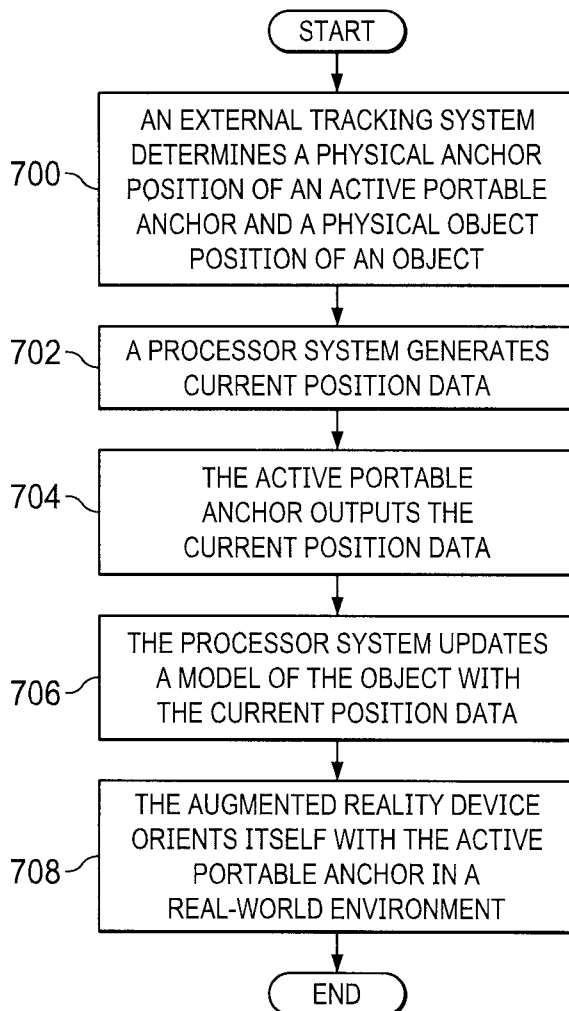

FIG. 7

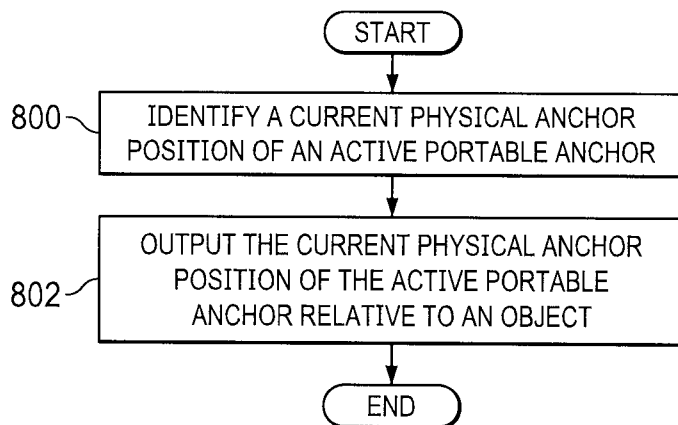

FIG. 8

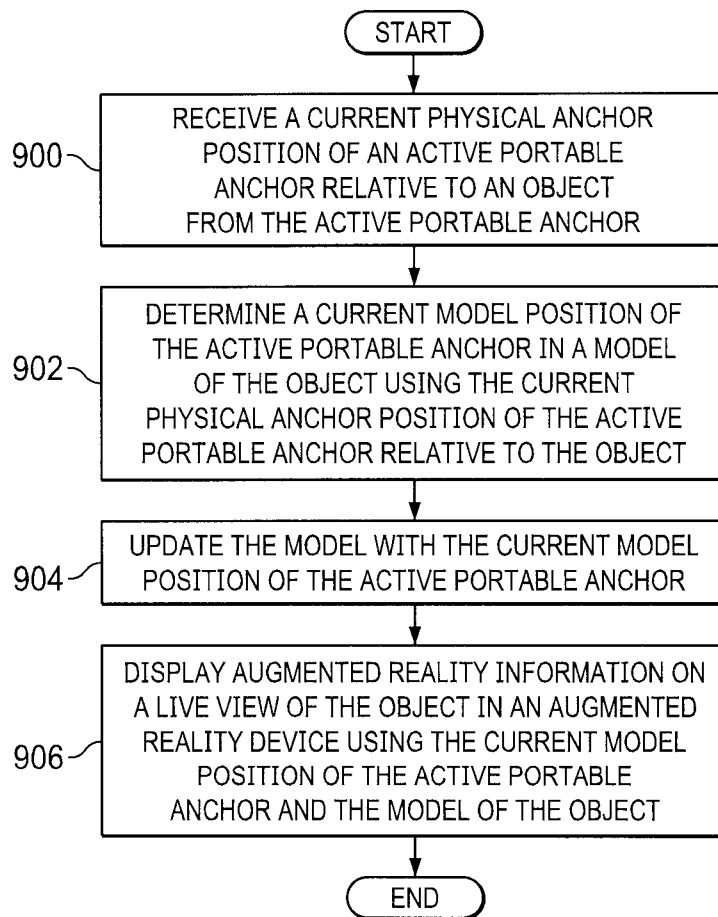

FIG. 9

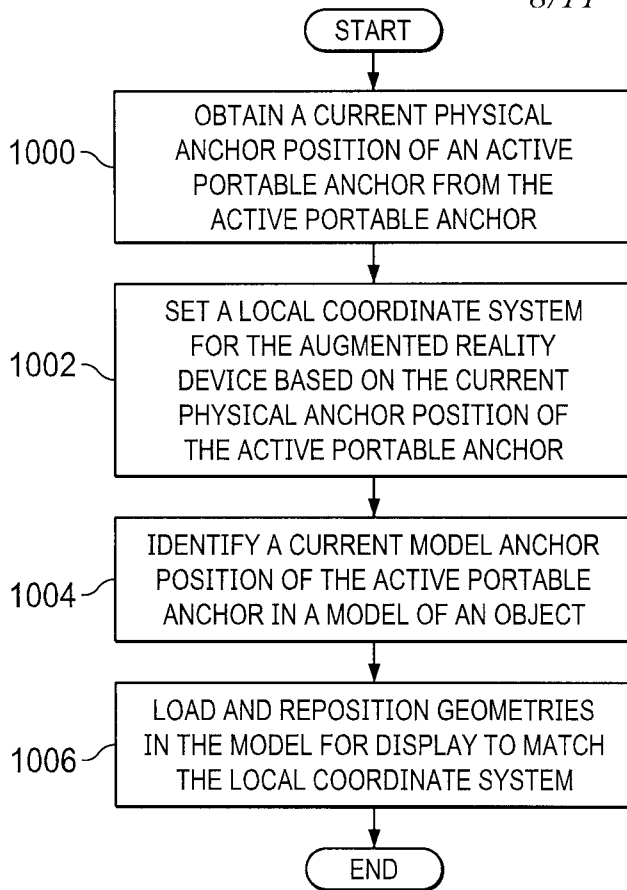

FIG. 10

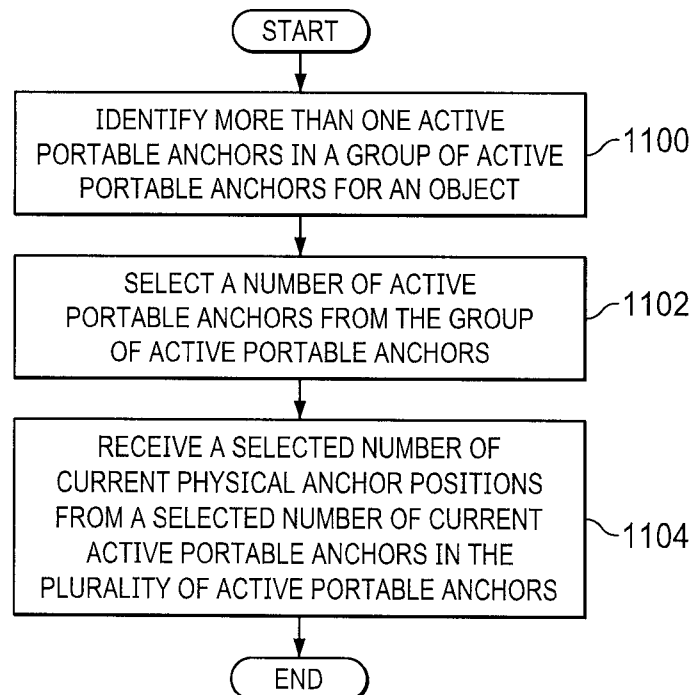

FIG. 11

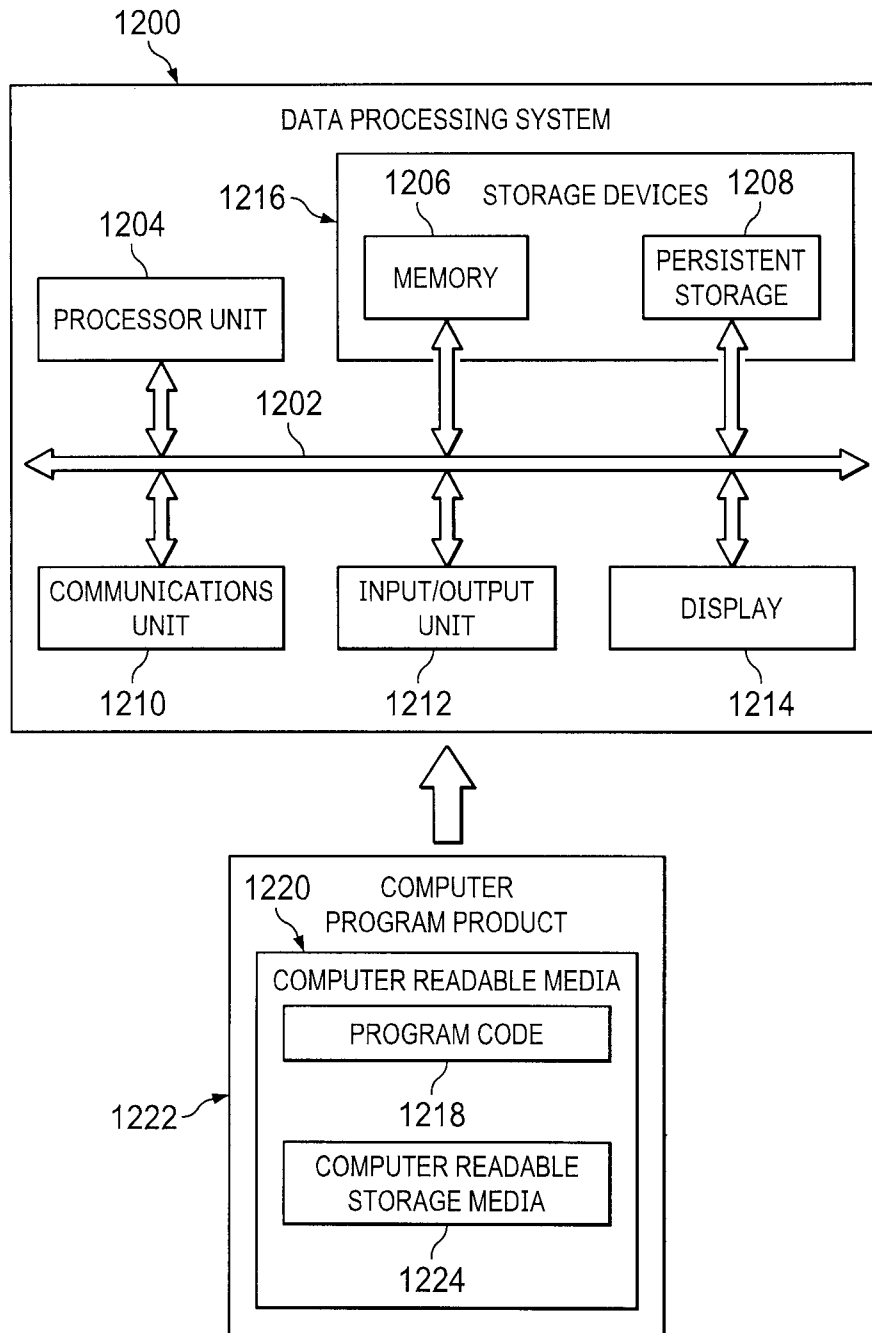

FIG. 12

10/11

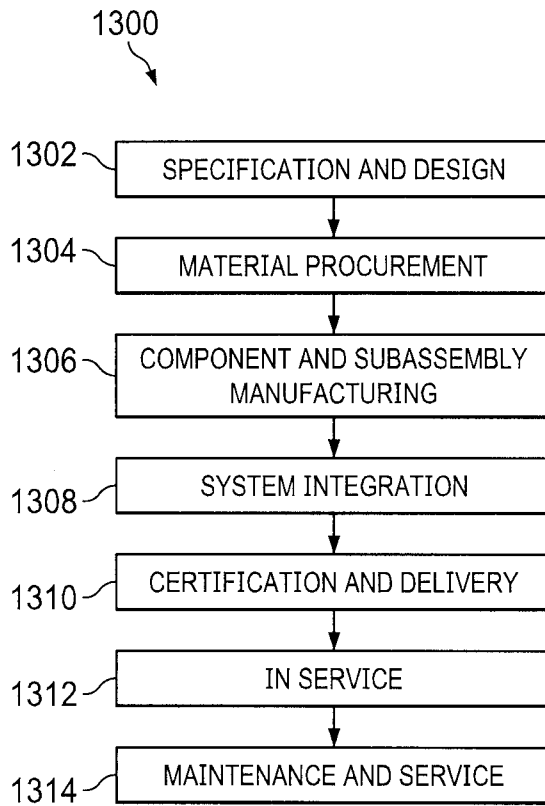

FIG. 13

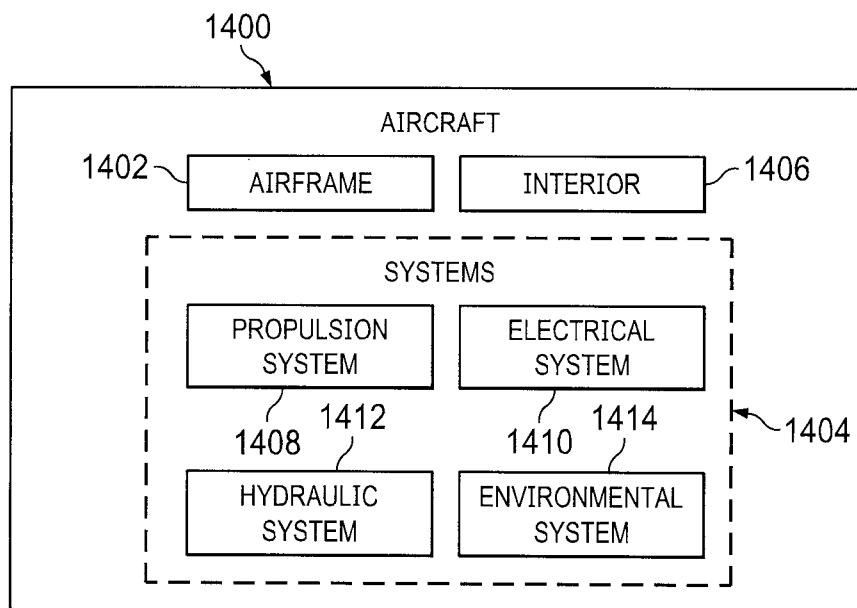

FIG. 14

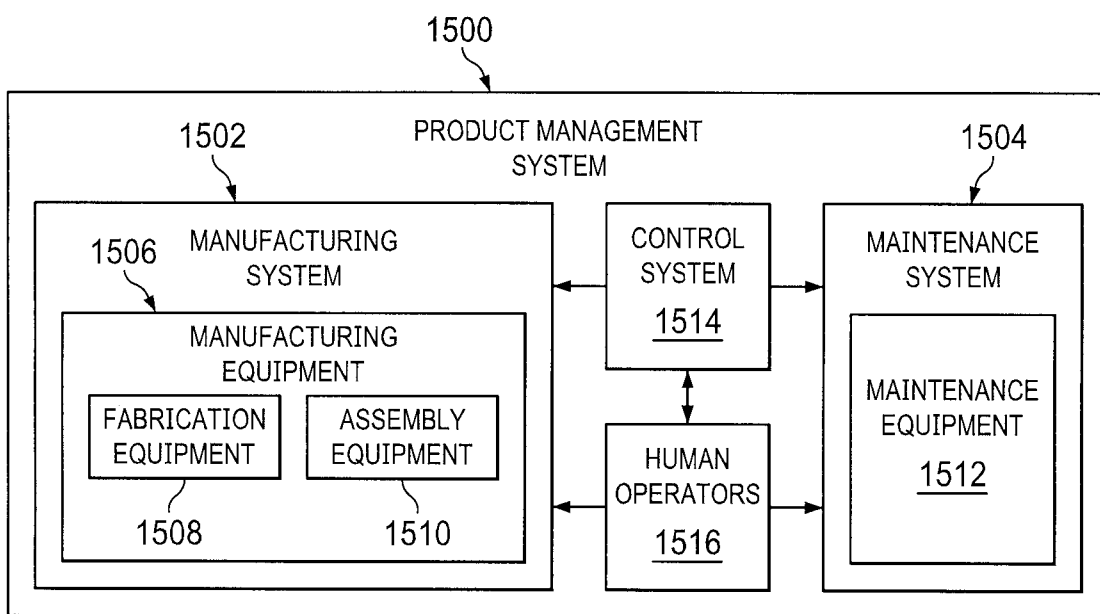

FIG. 15

