

J. H. RIDINGS.

COMBINED HAY RAKE, TEDDER, AND LOADER.

No. 521,247.

Patented June 12, 1894.

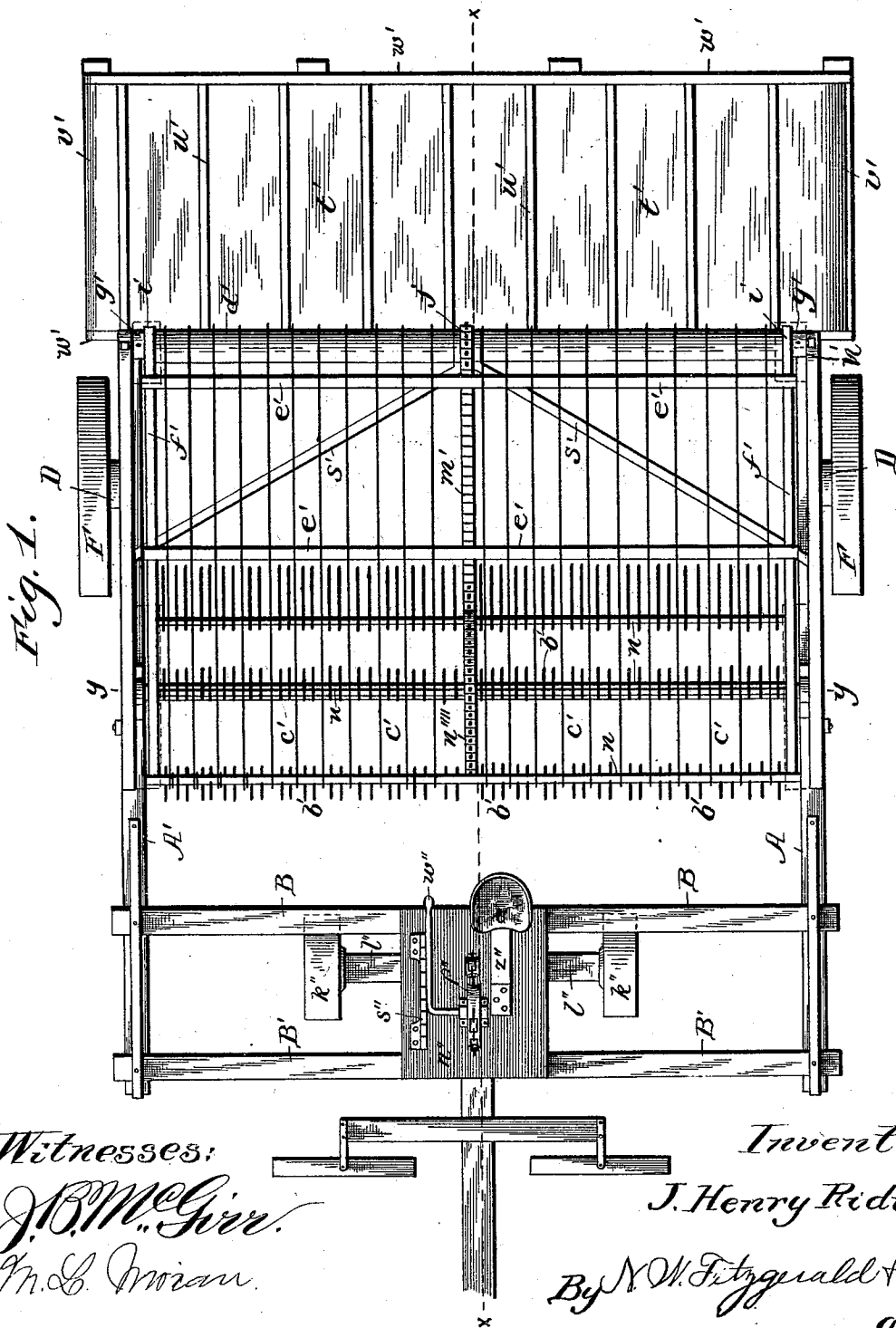

Witnesses:

J. B. McGinn.
W. L. Inman.

Inventor:

J. Henry Ridings

By W. H. Fitzgerald & Co.

attys

J. H. RIDINGS.

COMBINED HAY RAKE, TEDDER, AND LOADER.

No. 521,247.

Patented June 12, 1894.

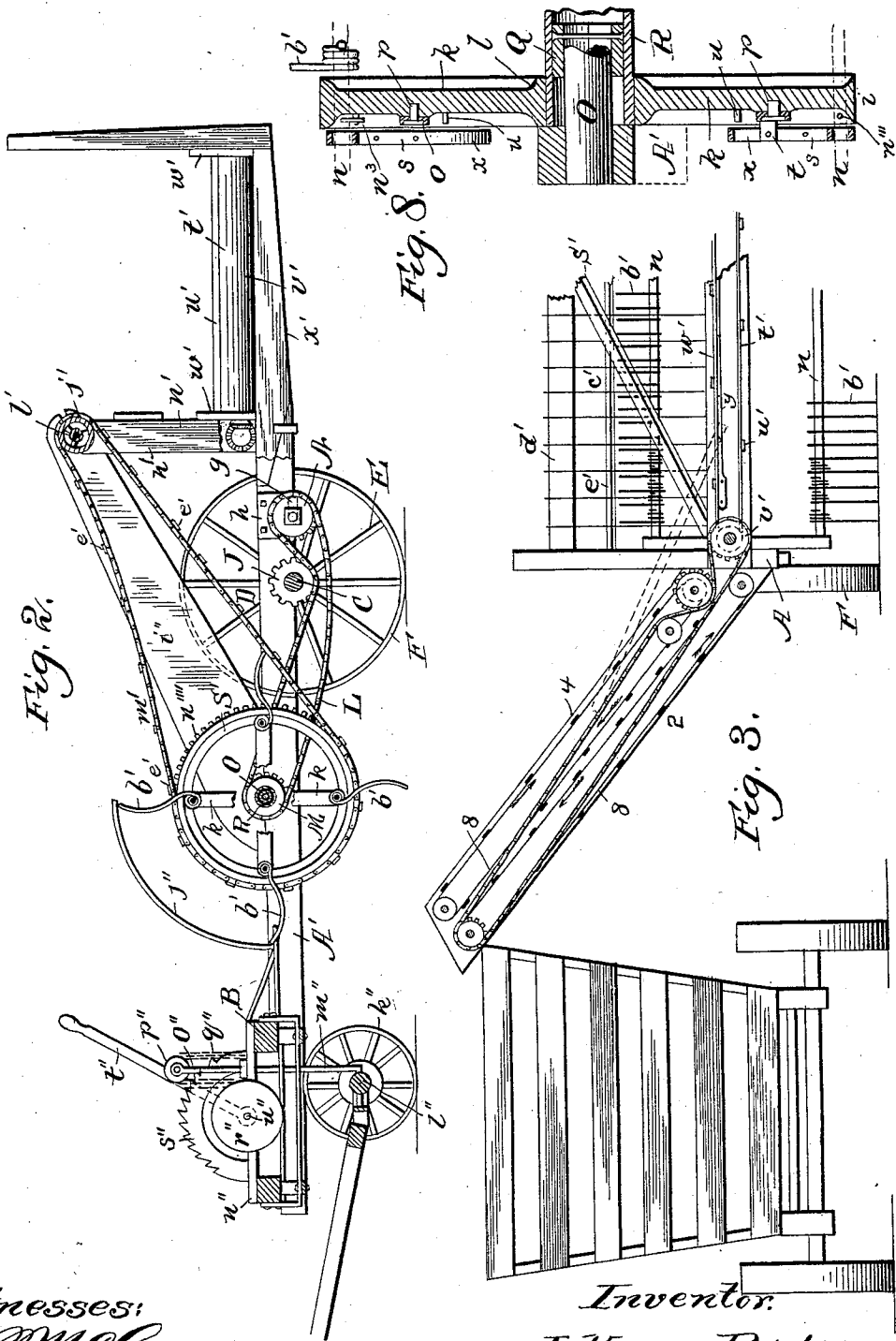

Witnesses:
J. B. McGirr.
M. L. Moran.

Inventor.
J. Henry Ridings
 By *N. W. Fitzgerald & Co.*

attys

J. H. RIDINGS.
COMBINED HAY RAKE, TEDDER, AND LOADER.

No. 521,247.

Patented June 12, 1894.

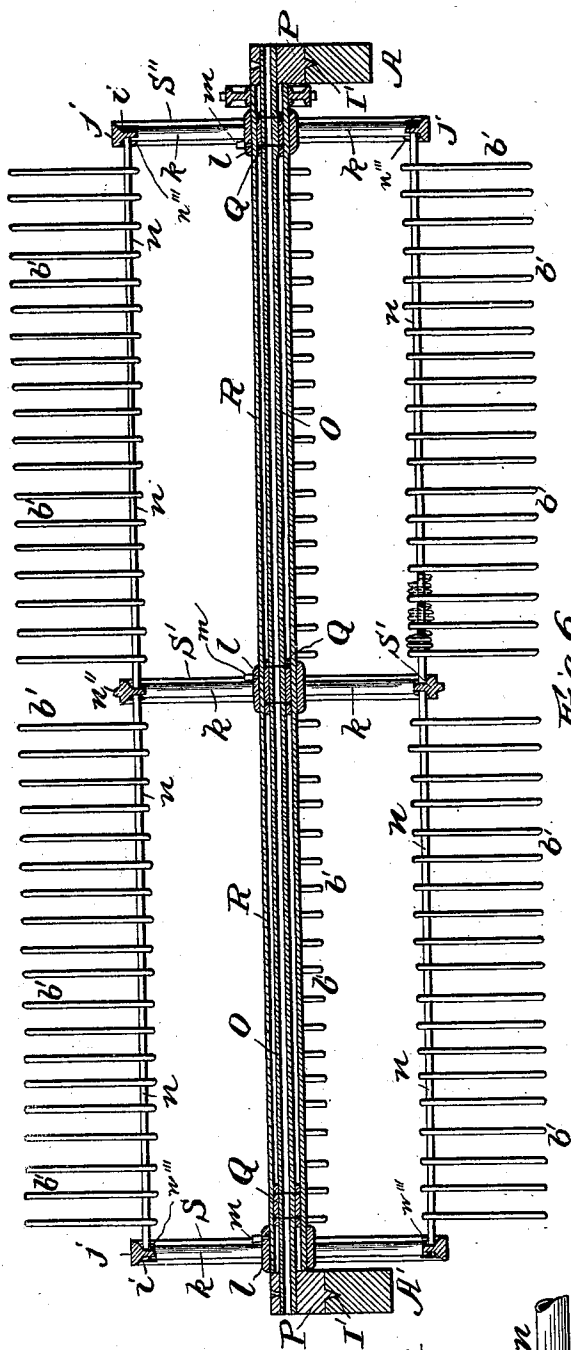

Fig. 4.

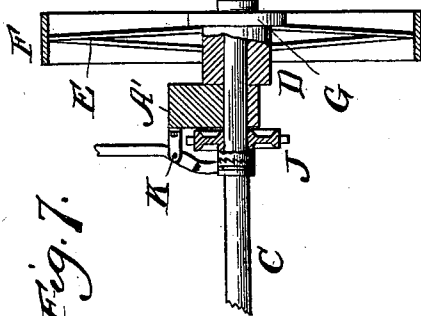

Fig. 7.

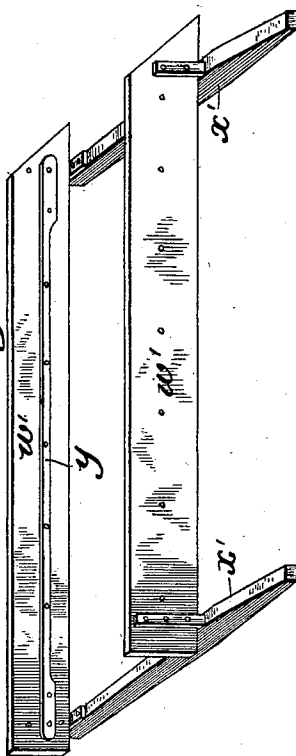

Fig. 6.

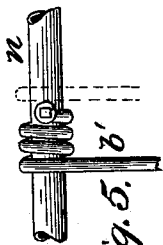

Fig. 5.

Witnesses:

J. B. McGivern
M. L. Moran

Fig. 4

Inventor:

J. Henry Ridings

By N. H. Fitzgerald & Co.
attys

(No Model.)

5 Sheets—Sheet 5.

J. H. RIDINGS. COMBINED HAY RAKE, TEDDER, AND LOADER.

No. 521,247.

Patented June 12, 1894.

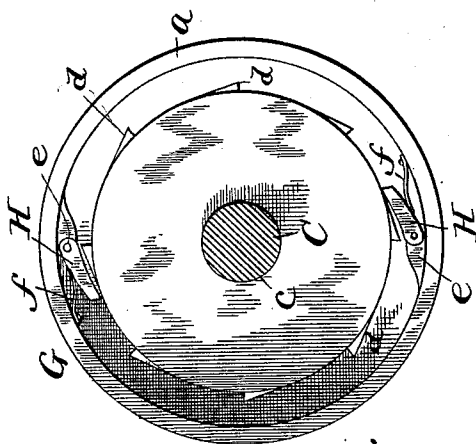

Fig. 13.

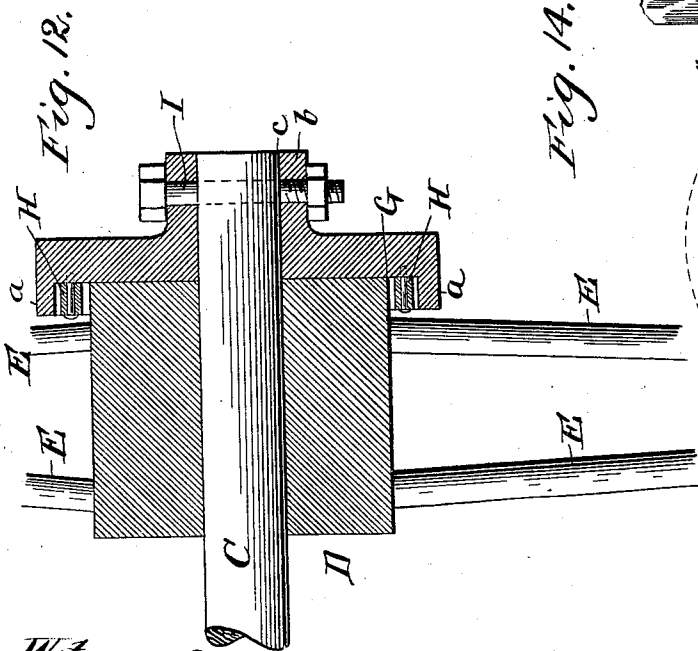

Fig. 12.

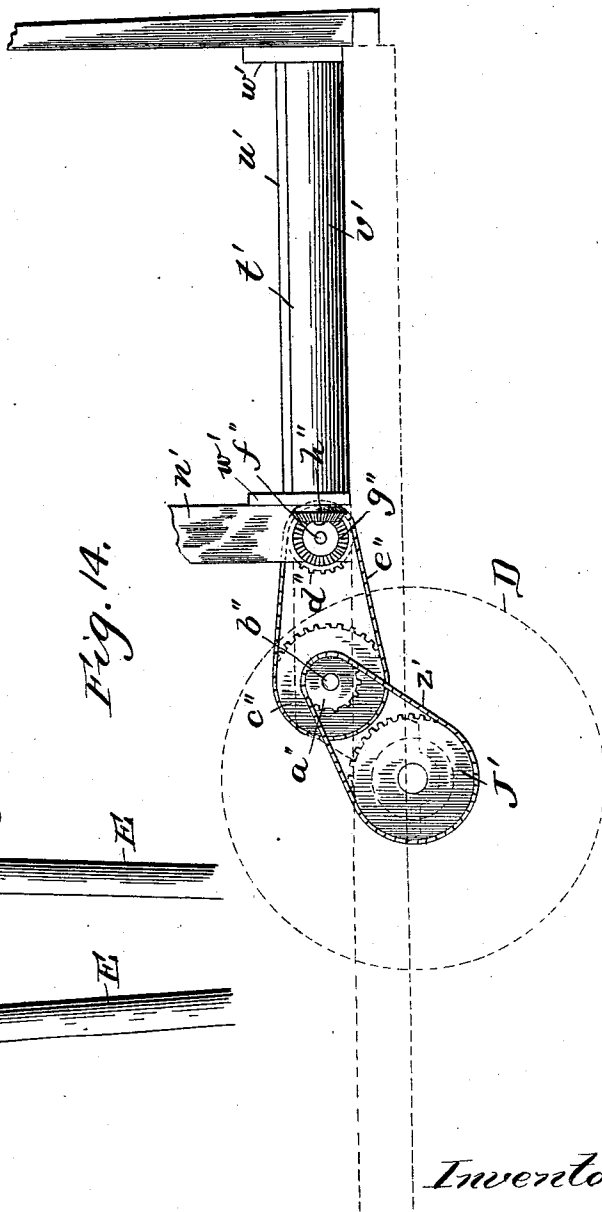

Fig. 14.

Witnesses:

J. B. McGivver
M. S. Moran

Inventor:

J. Henry Ridings

By *N. W. Fitzgerald & Co.*
attys.

UNITED STATES PATENT OFFICE.

JOHN HENRY RIDINGS, OF MORRIS, ILLINOIS.

COMBINED HAY RAKE, TEDDER, AND LOADER.

SPECIFICATION forming part of Letters Patent No. 521,247, dated June 12, 1894.

Application filed March 31, 1893. Renewed April 17, 1894. Serial No. 507,931. (No model.)

To all whom it may concern:

Be it known that I, JOHN HENRY RIDINGS, a citizen of the United States of America, residing at Morris, in the county of Grundy and State of Illinois, have invented certain new and useful Improvements in a Combined Hay Rake, Tedder, and Loader, of which the following is a specification, reference being had therein to the accompanying drawings.

My invention relates to a combined hay-rake, tedder, and loader of novel and improved construction; and this invention has for its object to provide an organization of apparatus assembled together in one concrete or unit machine capable, by special adjustments and arrangements, of the several particular functions or operations hereinafter described,—and furthermore, to produce a machine of this class which shall be simple and compact in construction, easy of interchange and adjustment, efficient in its several distinct operations, durable in use, accessible and interchangeable in all its essential parts, and comparatively inexpensive in cost and maintenance. For the attainment of these objects, and for other purposes hereinafter enumerated, my invention consists, in brief, in certain details of construction, arrangement and combination of parts, all of which will be more fully described hereinafter, and the specific points of novelty in which will be pointed out in the appended claims.

In the accompanying drawings, I have shown certain features and parts which I deem adequate for successfully carrying out my invention in practice, however, it will be clearly manifest that numerous minor changes, variations, and departures may be made without deviating from the spirit and scope of my invention as long as the fundamental principles of the same are adhered to, which principles are defined and set forth in the claims.

Referring to the said drawings forming a part of this specification:—Figure 1 is a top plan view of the complete machine as used as a hay-rake and side-deliverer, the latter mechanism being connected with a loader (not shown), or adapted to deposit the raked hay along the line of travel of the apparatus. Fig. 2 is a longitudinal vertical section taken on the plane indicated by the line $x-x$ Fig. 1. Fig. 3 is a rear elevation, partly in section, showing the loading mechanism arranged in

operative relation to the delivery mechanism shown in Figs. 1 and 2. Fig. 4 is a sectional view through the axis of the rotary raker and its attached and auxiliary mechanism, taken on the line $y-y$ of Fig. 1 the tripping mechanism on the outer head being removed in this view for the sake of clearness. Fig. 5 is a detail view showing the manner of securing a raking tooth to its support. Fig. 6 is a detail perspective view of the side-delivery frame. Fig. 7 is a detail view, partly in section and partly broken away, showing one end of the main or driving axle, one ground wheel thereon, the journal bearing, clutch-mechanism, &c., it being understood that the opposite end of the main axle is similarly arranged and provided. Fig. 8 is a detail sectional view of one of the raker cylinder-heads and its attached parts. Fig. 9 is a detail end elevation of Fig. 9. Fig. 10 is a detail sectional view through the center of the forward portion of the machine, showing the arrangement of the elevating lever and its co-operating devices. Fig. 11 is a rear elevation, partly in section, illustrating the construction and manner of supporting the roll at and above the edge of the side-delivery apron, which roll carries traveling conveyer-bands operated by the main cylinder. Fig. 12 is an enlarged detail section of one of the driving wheel hubs. Fig. 13 is a detail front or face elevation of Fig. 13; and Fig. 14 is a detail view showing the end of the side deliverer and the gearing for driving the same from the main axle.

Like letters and numerals of reference indicate the same or corresponding parts in the various views of the drawings.

The frame-work of the machine and other stationary and merely auxiliary parts are of such shape, size, strength, configuration, and material as found necessary or desirable under the demands of practice to support the incumbent and operating parts in their proper relative and co-operative positions; and therefore, the said frame-work, &c., may be changed and varied to correspond with such changes and variations in the structure as occasioned by experience or practical tests.

Referring to Figs. 1, 2, and 11, A, A', are the two side-beams of the frame, extending longitudinally on both sides of the machine, respectively, and are braced and held together rigidly at their front ends by cross-beams, B, B', and supported at their rear

ends by the main-axle, C, carrying at each extremity a drive-wheel, D, and mounted in bearings upon the side-beams, A, A'. The length of the main-axle, and the distance the side-beams are spaced apart approximately equal the width of the raking mechanism; and as I desire in practice to make machines of various raking widths, it will be obvious that the length of the main-axle is varied to suit the requirements, such as the various widths of mowing machines. The hub of each drive-wheel, D, is preferably of cast-iron with wrought iron spokes, E, E, secured in the hub at their inner ends, and at their outer extremities severally riveted into the rim or tread, F, of the drive-wheel. As shown, these spokes are set apart at their inner ends, and at their outer terminals are arranged in a common vertical plane to give strength and rigidity to the wheel, see Fig. 13. On the outer face of each hub is secured a disk-shaped cap, G, comprising an inwardly projecting horizontal circumferential flange, *a*, forming a circular recess on the inner face of the cap circumscribed by the flange, *a*, and a central outwardly projecting horizontal circular boss, *b*, longitudinally pierced by a circular bore, *c*, for the axle. This cap is slipped over the hub proper in the manner shown in Fig. 13; and the adjacent periphery of the hub is provided with a series of teeth or notches, *d*, *d*, designed to be engaged by the spring pressed dogs, H, H, pivotally attached to lugs, *e*, *e*, which, in turn, are fastened to the flange, *a*. The dogs are held in engagement with the teeth on the hub by a band-spring, *f*, one for each dog, attached rigidly at one end by a rivet to the flange, *a*, and having its free end exerting tension against the side of the pawl or dog. The cap, G, is keyed to the main-axle by the key-pin, I, consisting of a bolt fitted with a nut. By this construction, the drive wheels are prevented from backward movement yet are free to revolve in the opposite or forward direction.

The side-beams, A, A', are severally supported on the main-axle inside of the hubs of the drive-wheels, by ordinary boxes constituting bearings for the axle; and inside of each side-beam and in proximity thereto is a sprocket-wheel, J, or J', keyed rigidly to the main axle, the sprocket-wheel, J, driving the raking mechanism through the medium of a chain-belt, while the sprocket-wheel, J', imparts motion to the side-deliverer in a similar manner. Inside of each sprocket-wheel is an ordinary clutch-device, K, one being shown in dotted lines and the other in full lines in Fig. 7. By means of this clutch-mechanism, either sprocket-wheel may be thrown out of engagement with the main-axle, as will be readily understood.

L indicates a chain-belt running over sprocket-wheel J at the rear, and fitting over and communicating motion to the sprocket-wheel, M, on the rotatable cylinder-shaft at

the front of the machine. N is an idler-sprocket or belt-tightener journaled on its adjacent side-beam, and serving simply to maintain the belt in an engagement with the spurs of the sprocket-wheel, J. For this construction see Fig. 2. As shown in dotted lines in said figure, the arbor upon which the idler-wheel is journaled is made transversely movable and adjustable by being seated in an elongated slot, *g*, in a cast-plate, *h*, bolted to the side-beam, whereby the idler can be adjusted to vary the tension of the chain-belt by any ordinary device (not shown).

Referring now to Figs. 1, 2, 4, 9 and 10, O, is a stationary shaft of the raking cylinder fixed and supported at its respective extremities in stirrup-boxes, P, P, on the side-beams. As will be seen in Fig. 4, the lower half of each box, P, is provided on its under side with an angular downwardly projecting pointed tooth, I', which is driven down into the wooden side-beam and serves to keep the boxing there in place. In addition to this, the lower section of each box may be bolted to the side-beams to prevent any possibility of displacement. The shaft, O, is preferably hollow or tubular throughout its length, and accordingly, I make the same of a section of ordinary gas-pipe of sufficient diameter and strength, and of such length as to terminate at each end flush with the side-beams of the frame. Approximately at each end of the shaft, O, and also at its central point, is mounted thereon a stationary sectional boxing, Q, which I shall specifically term herein a "spacing boxing" owing to its peculiar function. Each of these boxings is made in two halves, each semi-cylindrical in shape, and bolted through the main-shaft by rivets passing through both halves of both boxings, and also through the cylinder-shaft. The heads of the rivets are countersunk to be flush with the exterior surface of each boxing, see Fig. 4. There are three boxings, P, on the cylinder-shaft,—one in the center, and two respectively near its extremities. One end boxing is about three inches from its adjacent side-beam, while the other is about four inches. Over the cylinder-shaft and its spacing-boxings, is rotatably fitted a larger gas-pipe or cylinder, R, and keyed thereto are three cylinder-heads or skeleton drums, S, S', S''; the heads, S, and S'', being severally on the extremities of the shaft, while the head, S', is mid-way the same. The two end-heads are keyed directly over and in vertical alignment with the end-boxings, and each cylinder-head comprises a narrow metallic rim or tread, *z*, held in position and stayed by radial spokes, *k*, *k*, projecting from a central hub or web, *l*. In a suitable aperture in the hub is secured the key-pin, *m*, by which each cylinder-head is fastened to the shaft, R. Transversely through each rim, *z*, are made four openings to receive and hold the four transversely extending shafts, *n*, *n*, which, in turn, carry the movable raking teeth of the

cylinder. These shafts, n, n , are held against
 endwise movement in the openings of the
 heads by transverse limit-pins, n''', n''' ,
 respectively at the ends of said shafts, as
 shown. As will be seen by an inspection
 of Fig. 10, there are four spokes, k, k , and at a
 point near the outer end of each spoke is piv-
 oted a spring-actuated pawl, o , attached to
 the face of the spoke by a pivot-pin, p , and
 working against the tension of the band-
 spring, q , fastened at one end by a rivet to the
 side of the spoke, and pressing at its other
 free end against the curved rear end of the
 pawl, o . The forward curved portion of the
 pawl is provided with a sloping notch or rec-
 cess, r , designed to receive and hold a detent
 on a trip-lever on the end of a raker-teeth
 shaft, as hereinafter explained.

On one side of the machine, the ends of
 the cross-shafts, n, n , project through the per-
 forations in the rim of the cylinder-head a
 prescribed distance, and on such protruding
 ends are rigidly secured the trip-levers, s, s ,
 each consisting of a strip of flat-iron looped
 at its rear end around the end of the shaft,
 doubled back upon itself, and there bolted,
 forming a tight connection around the end of
 the shaft. This trip-lever is in a vertical
 plane slightly beyond or outside of the adja-
 cent or corresponding pawl, o , and to each
 trip-lever approximately at the end of the
 loop is fastened a lateral detent or latch, t ,
 adapted to enter into and engage the sloping
 recess, r , in the pawl, o . Each pawl is lim-
 ited in its swing or movement by a stop-pin,
 u , on each spoke, k , slightly behind the pivot-
 pin, p . On the end of the stationary shaft,
 O , is rigidly secured the trip-roller arm, v ,
 fastened to said shaft in a similar manner to
 the trip-levers, s , and carrying at its forward
 extremity a cam-acting roller, w , journaled
 between the prongs formed on the end of
 said arm. The roller arm is arranged in the
 plane of the pawls, o , and projects out rad-
 ially from the shaft in such position that it
 will engage the curved rear ends of the pawls,
 o , successively as the latter begin to descend
 from their highest vertical position, and will
 throw the detents or latches, out of the rec-
 esses, r , just as the raker teeth, which are
 carried by the cross-shafts, n , deliver the
 raked up hay to the carriers. The liberation
 of the trip-levers allows the raker-teeth (by
 the rotation of the shafts, n), to be folded for-
 wardly upon the cylinder, out of the way of the
 cross-bars of the carrier-mechanism, as the
 raker-teeth are carried below the plane of the
 carrier and opposite the ground. They are re-
 turned to their operative positions success-
 ively by devices hereinafter described. This
 roller arm, v , projects at an angle of about forty-
 five degrees from a right-angle formed be-
 tween a horizontal plane of the shaft, O , and a
 vertical plane; and between such horizontal
 plane and the lowermost vertical position of
 the raker-teeth is another roller-arm, z , fixed
 to the shaft, O , in a manner similar to the roll-

er-arm, and in the vertical plane common to the
 trip-levers. At the outer end of the arm, z , is
 fixed the roller, a' , arranged in such position
 with relation to any descending trip-lever as
 to throw it back into such a position that the
 detent, t , will engage in the recess, r , as it be-
 gins to near its operative raking position at
 the bottom of the cylinder. The raker-teeth
 b', b' , are attached to the several shafts, n, n ,
 at regular intervals apart, as shown in Fig.
 4, and each tooth, b' , is made of a single piece
 of elastic metal, such as rod-steel or iron
 coiled at its inner end around the particular
 shaft, n , and riveted there in position, see Fig.
 9. The outer ends of all the raker-teeth on
 each shaft are in the same plane and project
 radially from their supports. Between any
 adjacent pair of teeth, b' , travels an endless
 carrier or band, c' , encircling the shafts, n, n ,
 at its forward end or turn, and running over
 a roll, d' , at the rear of the machine, which
 roll is in a higher horizontal plane than the
 cylinder at the front. Thus, it will be un-
 derstood that there are a number of endless
 bands, c' , arranged to travel parallel and side
 by side over the raker-cylinder and the roll,
 d' . These bands are tied transversely to-
 gether by cross-bars, e' , spaced apart equal
 distances and wide enough for the purposes
 of operation. The connection between the
 cross-bars, e' , and the bands, c' is made by
 the latter being coiled around the respective
 bars by a single turn or convolution. At
 each side of the machine the several ends of
 the cross-bars, e', e' , are fastened to the belts
 or chains, f' , which are carried by the smooth
 treads, i , of the end-cylinder-heads and the
 ends of the roller, d' . The treads, i , may be
 grooved to prevent the belts or chains from
 slipping laterally if desired.

From the foregoing description, it will be
 apparent that as the raker-teeth carry up the
 hay the latter is delivered by the teeth to the
 carriers and conveyed back to the rear by the
 same. At the same time the delivery is made
 the trip-mechanism throws the raker-teeth
 out of rigid position so as to permit them to
 fly back out of the way of the cross-bars
 which fit up against each set of teeth. Then,
 as such raker-teeth descend coming nearer
 their renewed operative raking positions,
 they are again thrown into rigid or set posi-
 tion by the roller, a' .

The first action of the tripping mechanism
 causes the raker-teeth to fly back and release
 the hay, as well as permitting them to be out
 of the way of the cross-bars.

The roller, d' , is journaled at both ends in
 the uprights or standards, n', n' , and is di-
 vided centrally to permit the sprocket wheel,
 j' , to be keyed in the annular recess thus
 formed between the adjacent faces of the
 roller. This sprocket-wheel is keyed to the
 roller shaft, consisting of the gas-pipe, l' , run-
 ning centrally and longitudinally of the roll,
 see Fig. 12. A sprocket-chain, m' , travels
 over the sprocket, j' , and the sprocket n''''

on the central cylinder-head, S' ; and to this sprocket chain are secured the centers of the cross-bars of the endless carriers. In this manner motion is communicated from the cylinder to the roller, d' .

The roller, d' , is supported centrally by the bifurcated casting, o' , consisting of the two bearing arms, p' , p' serving as journal supports for the gas-pipe or shaft, l' , and the splayed attaching wings, q' , q' , bolted to the apex of the inverted V-shaped frame, r' , comprising the two oblique standards s' , s' , joined at their converging and abutting ends at an acute angle, as shown in Fig. 12, and attached severally at their opposite extremities to the side-beams, A , A' . Thus the rear roller, d' , is supported at its ends by the vertical standards, n' , n' , and at its central point by the casting, o' , on the frame, r' .

Referring now to Figs. 1, 2, and 6, the side-delivery mechanism is placed transversely of the machine behind the rear roller, d' , and in a lower horizontal plane than the latter so that hay carried back by the carriers will drop by gravity on the side-deliverer, and be delivered by the same either upon the ground or to the loading mechanism hereinafter described. This side delivery mechanism consists of an endless apron or canvas, t' , provided with surface cross-slats, u' , extending across the width of the canvas, and spaced a certain distance apart. The carrier apron, t' , runs over two rolls, v' , v' , respectively at the ends of the side-deliverer, each roll being suitably journaled at its ends in the side-plates, w' , of the side-delivery frame. The framework of this mechanism comprises two backwardly extending extension-bars, x' , attached severally at their inner ends to the ends of the side-beams, A , A' , and serving as supports for the several parts of the side-deliverer. The side-plates, w' , are removably fastened in a vertical manner to the extension-bars, x' , and are each rectangular in shape with one extremity square while the other is chamfered or inclined, as shown. These two plates are spaced a distance apart approximately equal to the width of the carrier apron, and each is provided on its inner surface adjacent to the edge of the said apron with a strip, y , bolted thereon and forming a guideway for the ends of the cross-slats of the apron.

As shown in Fig. 15, motion is communicated to the side-delivery apron by means of a sprocket-chain, z' , running over the sprocket-wheel, J' , at one end, and over the sprocket-pinion, a'' , at the other end. The pinion, a'' , is keyed to a stud-shaft, b'' , journaled to the frame-work and carries another sprocket-wheel, c'' , which is connected to the sprocket-wheel, d'' , by a chain-belt, e'' . The sprocket, d'' , is on a counter-shaft, f'' , journaled on one of the side-beams, and carries a bevel-gear, g'' , intermeshing with a pinion, h'' , on the end of one of the shafts of a roll, v' .

i'' , i'' , respectively designate side-boards

or guides of the frame of the machine, each made of the required material and in the desired shape and dimensions. In front each side-board is fastened to the adjacent side-beam by an angle-iron (not shown) which is bolted to the side beam and to the outer side of the board. At the rear, each side board is supported at the top of the end-frame in a suitable manner (not shown), thus occupying an inclined position. The ends of the roller-shaft, l' , extend through slotted bearing openings in the rear ends of these boards.

In Fig. 2 is shown a shield or guard embracing the end of the cylinder to keep the hay from being caught by any of the moving parts. This shield or guard is not shown in any other view and forms no material of novel feature of my invention.

k'' , k'' , indicate severally the ground-wheels at the front of the machine, each of suitable size, strength, and construction, and journaled on the respective ends of the front-axle, l'' , which in turn, is attached rigidly at its center to a vertical shaft, m'' , passing up through a cross-plate, n'' , on the front-platform of the machine, and terminating in a forked support, o'' , for the roller, p'' . This support, o'' , is swiveled in the end of the shaft and between the prongs of the same the roller, p'' , is journaled. Over this roller passes a chain, q'' , fastened at one end to one of the cross-bars of the frame, and at its other, attached to the winding drum, r'' , trunnioned in end-bearings in the frame.

s'' is an arc-shaped rack-bar bolted to the platform, and serves to hold the vibratory crank-lever, t'' , keyed at its lower end to the drum-shaft, w'' , and provided at its upper end with a pawl-lever, v'' , having a pivotally connected lever handle, w'' , at its upper end, and jointed to the stop-pawl, x'' , at its lower extremity. By this construction, the operator can, by swinging the lever in the proper direction, raise and lower the front portion of the frame-work to which the chain is attached, by winding or unwinding the latter about the drum, r'' , the rack-bar and operating lever serving to hold the chain in any desired position about the drum.

The front platform and framework of the machine are made of suitable strength and configuration to suit requirements, having brace-rods, cross bars, foot-rests, &c. On the front-platform is an inclined standard, z'' , secured at its lower end to the framework, and at its upper end carrying an ordinary seat for the operator. The construction of the parts just described is shown in Figs. 1, 2, and 11.

The draft-appliances are secured to the front-axle and are of any desired or approved construction.

From the foregoing description, it will be understood, that by using all the parts described, except the side-delivery apparatus, the hay can be raked up and passed back over the rear roller, d' , to the ground, the hay

being lifted in advance of the center of the cylinder and carried back in a continuous sheet. In this capacity the machine would be in the nature of a tedder for raking up the hay and aerating it; then dropping it lightly on the ground. With the side deliverer, it would deposit the hay sidewise or laterally of the machine in a continuous windrow.

The side-delivery-mechanism is made detachable from the rear end of the machine so that it may be readily removed according to the demands of operation by any approved or ordinary means (not shown).

In conjunction with the side-delivery rake I employ an automatic loading mechanism which I shall proceed to describe in detail.

Referring to Fig. 2 indicates an inclined chute which is fixed detachably to the discharge end of the side-delivery frame, in any suitable manner and it comprises the side-plates 4, 4, each made of sheet metal such as steel with inturned guiding flanges to prevent the bellying of the endless carrier hereinafter described. The open lower end of this chute communicates with the side-deliverer, and it is so supported as to prevent sagging, any approved securing and bracing devices being employed. Two endless aprons or carriers, 8, 8, are arranged to travel up through the chute with their inner adjacent surfaces separated a prescribed distance and traveling in the same direction, that is, upwardly. By means of these two carriers, the hay is elevated to the top of the chute and dropped into a wagon. The train of sprocket-gearing is shown clearly in Fig. 3 so arranged that it gives motion to the inner surfaces of the carriers in the same direction, and can be varied and changed according to requirements. Such gearing receives its motion from the roll, *v'*. The inner sides of the side-plates, 4, 4, are provided with guide ways similar to those on the side-plates of the side-deliverer, there being two guide-strips on each side-plate, one for each apron or carrier. The aprons, 8, 8, are each provided on their outer surfaces with spaced carrying slats arranged corresponding to those on the apron of the side-deliverer, and having their ends in engagement with, and traveling under, the guide-strips on the inner side of the side-plates.

In operation, the hay is raked up by the slightly curved raker-teeth of the cylinder, and carried back by the endless carriers, *c'*, and dropped off lightly behind the machine on the ground. In this operation, no appreciable amount of the hay is turned over, it being simply raked up and lightly and gently dropped behind the machine thus subjecting it to an aerating process, and leaving it on the ground in loose layers through which the air and sun can readily penetrate, thus facilitating the curing of the same. This method of handling hay that has been subjected to a heavy dew or rain will be found greatly advantageous, and moreover, will serve to

loosen hay pressed down by the wheels of the mower, or which has been trodden in a packed mass by the hoofs of the draft horses.

When in use in the aforesaid capacity, my machine is in the nature of a tedder.

The operation of raking the hay from the ground may be briefly set forth as follows: As the drive-wheels of the machine are making one full revolution, they travel about twelve feet, and now dividing the twelve feet by four (there being four raker-teeth-shafts) I find a width of thirty-six inches raked by one row of raker-teeth, and while the machine is practically stationary, one row of teeth will rake eighteen inches of the ground; thus, the raking is effected half by the raker-cylinder and half by the forward movement of the machine, and the slight scraping action due to this movement presses the masses of hay closely together, and is thereby instrumental in producing clean and thorough work.

When the side-delivery attachment is in use, the machine is called a side-delivery rake. The object of throwing the hay sidewise in continuous windrows is to deposit the same in a position that a supplemental loader may conveniently carry it up into a wagon. When the operator desires to throw the hay upon the ground with the side-deliverer, the width of two swaths can be thrown into one common windrow by projecting one width of rake onto another, and then throwing the two onto stubble. In the old forms of loaders a greater part of the hay is left upon the ground, but with my invention this difficulty is entirely obviated.

When my improved loader is in an operative position, the hay is taken from the discharge end of the side-deliverer, and conveyed to the top of the chute, from which point it is dropped into a wagon which is arranged beside and moves with the harvester.

The advantage derived from the arrangement of the loader, whereby it projects laterally from, and is carried by, the harvester frame is as follows:—A hay-fork such as is ordinarily employed for transferring the hay from the wagon to the barn-loft is capable of lifting about one-half of a wagon-load, that is, the front or rear half, at one time. When hay is deposited in the wagon from the rear end, it becomes twisted or intermeshed, and no dividing line is formed between the front and rear portions of the load. But when the loading is accomplished from the side, as contemplated hereby, (the wagon being driven abreast with the harvester and parallel therewith) the front half may be filled and subsequently (the team being driven ahead sufficiently) the rear half may also be filled, thus enabling the load to be removed readily by means of a fork.

All the parts of the machine are simple, durable and interchangeable, and can be kept in repair and operative condition by any unskilled person. Suitable lubricating orifices

or devices are provided throughout, and in deed, all mechanical expedients for efficiency and convenience are present.

Having thus fully described my invention, what I claim, and desire to secure by Letters Patent, is—

1. In a combined hay-rake, tedder, and loader, the combination, of a suitable framework vertically adjustable at its front or draft end; a raker cylinder rotatably mounted on the front end of the machine; a series of raker-teeth mounted in rows on shafts journaled around the surface of said cylinder; a detent arm on the end of each shaft; a spring-pressed pawl pivoted to the cylinder and adapted to hold the detent arm in a set raking position; a trip roller supported in stationary position and adapted to throw the pawl out of engagement with the detent arm; another roller similarly arranged and supported for throwing the detent arm back into set position in engagement with the pawl after the aforesaid disengagement; an endless carrier arranged in operative relation to the raker-cylinder at the front, and communicating with a side-delivery mechanism at its rear; a side delivery mechanism detachably secured at the rear end of the framework; and an automatic loader detachably fixed to the side-delivery mechanism and adapted to carry up and deliver the hay into a wagon traveling alongside.

2. In a machine of the class described, the combination, with a suitable framework supported by ground-wheels; of a raker-cylinder on the front portion of the framework and rotatably mounted on a stationary transverse shaft located in front of the driving axle; rows of movable raking teeth on the raker-cylinder; tripping mechanism for throwing said teeth into and out of operative position; and comprising a series of spring-pressed pawls and co-acting detents controlling the positions of the raking teeth of the raker-cylinder, a trip-roller carried by the stationary transverse shaft and adapted to throw the pawls out of engagement with their detents, and another trip-roller similarly arranged on the transverse shaft in a different vertical plane and designed to replace the detents in engagement with their pawls after disengagement sprocket gearing driving said cylinder; and the driving axle carrying drive-wheels and connected with the raker-cylinder by intermediate sprocket-gearing.

3. In a machine of the class described, the combination, with a suitable framework supported by ground wheels; of a raker-cylinder rotatably mounted upon a fixed support on the forward part of the machine in advance of the driving axle; a series of movable raker-teeth carried by said cylinder; tripping mechanism on one end of said cylinder and arranged to automatically throw said teeth into and out of operative position; and comprising a series of spring-pressed pawls and co-acting detents controlling the positions of the

raking teeth of the raker-cylinder, a trip-roller carried by the stationary transverse shaft and adapted to throw the pawls out of engagement with their detents, and another trip-roller similarly arranged on the transverse shaft in a different vertical plane and designed to replace the detents in engagement with their pawls after disengagement bands or carriers arranged to receive and carry back the hay from the rake; sprocket gearing for imparting motion both to the rake and to the carriers; and a main axle carrying drive-wheels and connected with the raker-cylinder and carrier mechanism by intermediate sprocket-gearing.

4. In a machine of the class described, the combination, with a raker-cylinder rotatably mounted on the machine, of a series of raker-teeth mounted in rows on shafts journaled around the periphery of said cylinder,—a detent-arm on the end of each shaft,—a spring-pressed pawl pivoted to the cylinder and adapted to hold the detent arm in a set raking position,—a trip-roller supported in stationary position and adapted to throw the pawl out of engagement with the detent-arm,—and another trip-roller similarly arranged and supported for throwing the detent-arm back into set position in engagement with the pawl after the aforesaid disengagement.

5. In a machine of the class described, the combination with the raker-cylinder comprising three cylinder heads carrying transverse shafts serially disposed around the surface of the cylinder and provided with movable raker-teeth; of a tubular shaft to which said heads are keyed; and a tubular stationary support for the tubular shaft of the cylinder, provided with spacing boxings to separate the two shafts from each other.

6. In a machine of the class described, the combination, with the raker-cylinder having two smooth end-heads and a central head, the latter being provided with spurs around its periphery, all of said heads being keyed on a tubular shaft enveloping a stationary support fixed to the framework—of a sprocket-belt passing over the central head,—a roll at the rear of the machine journaled in suitable supports and carrying a centrally disposed sprocket-wheel in alignment with the central head of the cylinder and in engagement with the said sprocket-belt,—loose belts carried by the end-heads and rear roll,—intermediate bands traveling around the raker-cylinder and rear roll,—raker-teeth arranged in rows on the raker-cylinder with a carrier band between any two adjacent pair of raker-teeth,—and means for actuating the cylinder, sprocket-wheels, belts, and bands.

In testimony whereof I affix my signature in presence of two witnesses.

J. HENRY RIDINGS.

Witnesses:
E. L. PLOVER,
A. G. WOODBURY.