

(19)



(11)

EP 4 216 740 B1

(12)

EUROPEAN PATENT SPECIFICATION

(45) Date of publication and mention of the grant of the patent:
06.11.2024 Bulletin 2024/45

(21) Application number: **21778490.9**

(22) Date of filing: **21.09.2021**

(51) International Patent Classification (IPC):
A24F 40/42^(2020.01) A24F 40/485^(2020.01)

(52) Cooperative Patent Classification (CPC):
A24F 40/42; A24F 40/465; A24F 40/485; A24F 40/10

(86) International application number:
PCT/EP2021/075974

(87) International publication number:
WO 2022/063793 (31.03.2022 Gazette 2022/13)

(54) **AN AEROSOL-GENERATING SYSTEM AND A CARTRIDGE FOR AN AEROSOL-GENERATING SYSTEM WITH A SEALED LIQUID RESERVOIR**

AEROSOLERZEUGENDES SYSTEM UND KARTUSCHE FÜR EIN AEROSOLERZEUGENDES SYSTEM MIT EINEM ABGEDICHTETEN FLÜSSIGKEITSRESERVOIR

SYSTÈME DE GÉNÉRATION D'AÉROSOL ET CARTOUCHE POUR UN SYSTÈME DE GÉNÉRATION D'AÉROSOL COMPORTANT UN RÉSERVOIR DE LIQUIDE SCELLÉ

(84) Designated Contracting States:
AL AT BE BG CH CY CZ DE DK EE ES FI FR GB GR HR HU IE IS IT LI LT LU LV MC MK MT NL NO PL PT RO RS SE SI SK SM TR

(30) Priority: **23.09.2020 EP 20197786**

(43) Date of publication of application:
02.08.2023 Bulletin 2023/31

(73) Proprietor: **Philip Morris Products S.A. 2000 Neuchâtel (CH)**

(72) Inventor: **FREDERICK, Guillaume 2000 Neuchâtel (CH)**

(74) Representative: **Reddie & Grose LLP The White Chapel Building 10 Whitechapel High Street London E1 8QS (GB)**

(56) References cited:
**EP-A1- 3 463 534 EP-B1- 3 463 534
WO-A1-2013/159245 WO-A1-2015/180168
WO-A1-2019/105811 US-A1- 2015 305 406
US-A1- 2015 342 257 US-A1- 2016 029 699**

EP 4 216 740 B1

Note: Within nine months of the publication of the mention of the grant of the European patent in the European Patent Bulletin, any person may give notice to the European Patent Office of opposition to that patent, in accordance with the Implementing Regulations. Notice of opposition shall not be deemed to have been filed until the opposition fee has been paid. (Art. 99(1) European Patent Convention).

Description

[0001] The present disclosure relates to an aerosol-generating system and a cartridge for an aerosol-generating system. In particular, the present disclosure relates to an aerosol-generating system having and a cartridge for an aerosol-generating system that generates an aerosol by atomising a liquid aerosol-forming substrate.

[0002] Aerosol-generating systems that vapourise a liquid aerosol-forming substrate to generate an aerosol are well known. An e-cigarette is an example of this type of system. Using a liquid substrate has the advantage of allowing generation of large quantities of aerosol from a relatively compact source of aerosol-forming substrate. For aerosols for user inhalation, it is also desirable that the generated aerosol contains water and aerosol-formers that are in a liquid phase at temperatures suitable for user inhalation.

[0003] The liquid is typically stored in a liquid storage container or reservoir. The reservoir may be refillable or may be part of a disposable cartridge. During use, liquid must be able to leave the reservoir in order to form an aerosol that can be delivered to a user. However, leakage of liquid from the reservoir before use is undesirable, both because the amount of liquid then available for forming aerosol is reduced, and because leaked liquid may damage or interfere with operation of other components of the cartridge or system. It is also undesirable for contaminants to be able to enter the reservoir prior to use, as they may affect the quality of the aerosol produced by the system. It may further be desirable to prevent contact of the liquid aerosol-forming substrate with users' skin if the liquid aerosol-forming substrate contains substances that are irritating or harmful to the skin in the concentration that they are found in the liquid aerosol-forming substrate.

[0004] Typically, the liquid aerosol-forming substrate is contained in a cartridge and, prior to use, the whole cartridge is hermetically sealed in secondary packaging. This protects the liquid from contaminants during shipping and transport and protects the end user from contact with the liquid prior to use. However, this solution does not prevent leakage of liquid from the reservoir to other parts of the cartridge or system prior to use. As aerosol generating systems typically include electrical components that may not operate correctly in contact with liquid, this is undesirable. The requirement for the user to remove the sealed secondary packaging prior to use is also inconvenient for users.

[0005] WO2013159245A1 discloses an electronic cigarette that comprises a separate cartridge unit and a vaporiser unit. The cartridge unit has a cartridge tube containing a liquid with a seal sealing the liquid within the cartridge tube. The vaporiser unit has a piercer and a heater, with the front side of the vaporiser unit moveable into engagement with the cartridge unit, causing the piercer to pierce the seal in preparation for use of the electronic cigarette.

[0006] It would be desirable to provide a system and cartridge that allows liquid to be sealed from other components of the system during storage and transport and keeps liquid in pristine condition prior to use, but which is also more convenient for end users.

[0007] According to this disclosure there is provided a cartridge for an aerosol-generating system. The cartridge comprises a housing containing a sealed liquid reservoir. The cartridge comprises a heater assembly within the housing. The heater assembly comprises a heating element and a piercing element. The heater assembly is movable relative to the housing from a first position in which the piercing element is outside the sealed liquid reservoir to a second position in which the piercing element penetrates the liquid reservoir. The heater assembly comprises a sealing surface that forms a liquid tight seal with the housing or the liquid reservoir when the heater assembly is in the second position.

[0008] This arrangement allows the liquid aerosol-forming substrate to be sealed from other components of the cartridge prior to use. It also means that secondary packaging for the cartridge is not necessary. The liquid reservoir is unsealed by moving the heater assembly relative to the housing of the cartridge. This allows the reservoir to be unsealed by moving a relatively small component of the cartridge. In the second position, in which the piercing element penetrates the liquid reservoir and the reservoir is thereby unsealed, the liquid in the liquid reservoir may be able to flow or be transferred to the heater element of the heater assembly. The heater assembly may be configured to vaporise liquid at or close to the heater element. The cartridge may advantageously be configured to retain the liquid within the cartridge housing when the heater assembly is in the second position. The cartridge may be configured to allow vapour generated by the heater element to escape the cartridge when the heater assembly is in the second position.

[0009] The cartridge may be configured so that the heater assembly is moved from the first position to the second position as part of the normal process of coupling the cartridge to another component of the aerosol-generating system prior to use. The heater assembly may comprise an engagement surface facing away from the reservoir and accessible from an exterior the cartridge. The engagement surface may be pressed against a contact surface on the other component of the aerosol-generating system to move the heater assembly from the first position to the second position.

[0010] This arrangement also allows the heater assembly to be positioned close to the other component of the aerosol-generating system, which typically contains a source of power for the heating element, during use. This makes it less complex to deliver power to the heating element, both in embodiments in which power is delivered as electrical current through electrical connections and in embodiments in which power is delivered by electromagnetic induction.

[0011] The sealing surface that forms a liquid tight seal

with the housing or the liquid reservoir when the heater assembly is in the second position ensures that liquid is prevented from undesirably leaking from the housing during use. As used herein, a "liquid tight" seal means a seal that substantially prevents the passage of liquid and so prevents leakage of liquid. The sealing surface may advantageously form a liquid tight seal with the housing when the heater assembly is in the second position. The housing may advantageously be rigid and liquid impermeable. The sealing surface may form a liquid tight seal with the liquid reservoir when the heater assembly is in the second position. The liquid reservoir may be defined at least partially by the housing of the cartridge.

[0012] The liquid reservoir may be defined at least partially by a pierceable member. The pierceable member may comprise a sealing foil. In the second position, the piercing element may penetrate the sealing foil. The pierceable member may be a laminated foil. The pierceable member may comprise an elastomeric septum. The pierceable member may comprise a resilient plug. The pierceable member may form a liquid tight seal around the pierceable member.

[0013] The pierceable member may form a liquid tight seal with a remainder of a housing of the liquid reservoir prior to use of the cartridge, before the heater assembly is moved to the second position. The pierceable member may form a hermetic seal with a remainder of a housing of the liquid reservoir prior to use of the cartridge, before the heater assembly is moved to the second position. A hermetic seal may ensure that the liquid aerosol-forming substrate within the reservoir is maintained in pristine condition prior to use.

[0014] The heater assembly may be moved relative to the housing from the first position to the second position. The heater assembly may be moved relative to the housing from the first position to the second position in any suitable manner. In some embodiments, the heater assembly may slide relative to the housing. The heater assembly may slide relative to the housing in a direction parallel to a longitudinal axis of the system. The heater assembly may slide relative to the housing in a direction parallel to a direction in which the cartridge and a power supply component are coupled together. In some embodiments, the heater assembly may be rotatable relative to the housing.

[0015] The piercing element may be hollow. Liquid from the liquid reservoir may flow through the piercing element when the heater assembly is in the second position.

[0016] The heater assembly may comprise a plurality of piercing elements. The heater assembly may comprise two, three, four or more piercing elements.

[0017] The heater assembly may comprise a heater holder. The heater holder may comprise the piercing element or piercing elements. The heater holder may support the heating element.

[0018] The heater holder is configured to withstand the temperatures to which the heating element is raised for

heating of the aerosol-forming substrate.

[0019] The heater holder may be formed from any suitable materials that can withstand the temperatures to which the heating element is raised for heating of the aerosol-forming substrate. Preferably, the heater holder comprises a thermally insulative material. Advantageously, forming the heater holder from a thermally insulative material may minimise heat transfer from the heating element to the heater holder. Preferably, the heater holder comprises an electrically insulative material. The heater holder may be formed from a durable material. The heater holder may be formed from a liquid impermeable material. The heater holder may be formed from a mouldable plastics material, such as polypropylene (PP) or polyethylene terephthalate (PET). The heater holder may be a single moulded component comprising the piercing element or piercing elements.

[0020] In some embodiments, the heater holder is tubular. The tubular heater holder may define an internal passage or central bore. In some embodiments, the heater assembly extends into the internal passage of the heater holder. In some preferred embodiments, the heating element extends into the internal passage of the heater holder. The heating element may extend across the internal passage of the heater holder. The heating element may be supported by the heater holder to span the central bore. Where the heating element extends across the internal passage of the heater holder, the heating element may comprise a first mounting region at a first side of the heating element in contact with the heater holder, and a second mounting region at a second side of the heating element, opposite the first side, in contact with the heater holder. Advantageously, arranging the heating element to contact the heater holder at opposite sides may enable the heater holder to robustly secure the heating element in position in the cartridge.

[0021] The internal passage of the heater holder may extend substantially along a longitudinal axis. In some embodiments, the heating element is substantially planar, and the heating element extends parallel to the longitudinal axis. In some embodiments, the heating element is substantially planar and the heating element extends perpendicular to the longitudinal axis.

[0022] In some embodiments, the internal passage of the heater holder may form part of an air passage of the cartridge. In these embodiments, a heating region of the heating element may be arranged in the internal passage of the heater holder.

[0023] In some embodiments, the internal passage of the heater holder may form a wall of the liquid reservoir of the cartridge when the heater assembly is in the second position. In these embodiments, the at least one mounting region of the heating element may extend into the internal passage of the heater holder.

[0024] The tubular heater holder may comprise at least one side wall. The tubular heater holder may have an open end, such that the internal passage of the heater holder is open at least at one end. The at least one side

wall of the tubular heater holder may define an opening between the ends of the tubular heater holder. The at least one mounting region of the heating element may extend into the opening of the tubular heater holder. In some embodiments, where the heating element comprises a plurality of mounting regions, the at least one side wall of the tubular heater holder defines a plurality of openings between the ends of the tubular heater holder. In these embodiments, each mounting region of the heating element may extend into one of the plurality of openings of the at least one side wall of the tubular heater holder.

[0025] The heater holder may comprise the piercing element or piercing elements as a single moulded component.

[0026] The heater assembly may comprise a gasket. The sealing surface may be provided by the gasket. The gasket may be mounted on the heater holder. The gasket may comprise a plurality of sealing ribs, each rib forming part of the sealing surface and providing a seal with the outer housing. The gasket may comprise an elastomeric material. The ribs may comprise an elastomeric material. The gasket may be compressed between the cartridge housing and the heater holder when the heater assembly is in the second position.

[0027] The sealing surface may form a liquid tight seal with the housing when the heater assembly is in the first position. This prevents undesirable ingress of liquid into the cartridge prior to use.

[0028] The heater assembly may further comprise a wicking element. The wicking element may be in fluid communication with the heater element. The wicking element may be in fluid communication with the liquid reservoir when the heater assembly is in the second position. The wicking element may be arranged to convey aerosol-forming substrate from the liquid reservoir to the heating element. In particular, the wicking element may be arranged to convey aerosol-forming substrate from the liquid reservoir across a major surface of the heating element. The heating element may be fixed to the wicking element. The heating element may be integral with the wicking element. The heating element may comprise at least a portion of the wicking material.

[0029] The provision of a wicking element improves the wetting of the heating element and so increases aerosol generation by the system. It allows the heating element to be made from materials that do not themselves provide good wicking or wetting performance. The wicking element may be formed, for example, from cotton, rayon or glass fibre.

[0030] In some embodiments, the heating assembly comprises a plurality of heating elements. Where the heater assembly comprises a plurality of heating elements and a wicking element, each heating element may be arranged in fluid communication with the wicking element. In some embodiments, the heater assembly comprises a plurality of heating elements and a plurality of wicking elements.

[0031] In some preferred embodiments, the heater assembly comprises a first heating element, and a second heating element, the second heating element being spaced apart from the first heating element. A wicking element may be arranged in the space between the first heating element and the second heating element. In some particularly preferred embodiments, the first heating element, second heating element, and wicking element are substantially planar, and the first heating element is arranged at a first side of the planar wicking element, and the second heating element is arranged at a second side of the planar wicking element, opposite the first side.

[0032] Preferably, the heater assembly is arranged substantially outside of the liquid reservoir. In particular, the or each heating element of the heater assembly may be arranged substantially outside of the liquid reservoir. In particular, preferably, at least a portion of the major surfaces of the or each heating element is not in direct contact with the liquid reservoir in the first position or the second position. Preferably, at least a portion of each of two opposing major surfaces of the heater assembly are in direct contact with air in an airflow passage in the system.

[0033] In some embodiments, the cartridge contains a retention material for holding a liquid aerosol-forming substrate. The retention material may be positioned in the liquid reservoir, or between the liquid reservoir and the heating element. The retention material may be a foam material, a sponge material or a collection of fibres. The retention material may be formed from a polymer or co-polymer. In one embodiment, the retention material is a spun polymer. The retention material may be formed from any of the materials described above as suitable for the wicking element.

[0034] Where the aerosol-generating system comprises a wicking element and a retention material, the wicking element and the retention material may be formed from the same material, or different materials. The retention material may be in fluid communication with the heating element. The retention material may contact the heating element. The retention material may be in fluid contact with a wicking element of the heater assembly. The retention material may contact a wicking element of the heater assembly.

[0035] The cartridge may comprise an aerosol-forming substrate. As used herein, the term "aerosol-forming substrate" refers to a substrate capable of releasing volatile compounds that can form an aerosol. Volatile compounds may be released by heating the aerosol-forming substrate. Preferably, the liquid reservoir contains a liquid aerosol-forming substrate.

[0036] The aerosol-forming substrate may be liquid at room temperature. The aerosol-forming substrate may comprise both liquid and solid components. The liquid aerosol-forming substrate may comprise nicotine. The nicotine containing liquid aerosol-forming substrate may be a nicotine salt matrix. The liquid aerosol-forming sub-

strate may comprise plant-based material. The liquid aerosol-forming substrate may comprise tobacco. The liquid aerosol-forming substrate may comprise a tobacco-containing material containing volatile tobacco flavour compounds, which are released from the aerosol-forming substrate upon heating. The liquid aerosol-forming substrate may comprise homogenised tobacco material. The liquid aerosol-forming substrate may comprise a non-tobacco-containing material. The liquid aerosol-forming substrate may comprise homogenised plant-based material.

[0037] The liquid aerosol-forming substrate may comprise one or more aerosol-formers. An aerosol-former is any suitable known compound or mixture of compounds that, in use, facilitates formation of a dense and stable aerosol and that is substantially resistant to thermal degradation at the temperature of operation of the system. Examples of suitable aerosol formers include glycerine and propylene glycol. Suitable aerosol-formers are well known in the art and include, but are not limited to: polyhydric alcohols, such as triethylene glycol, 1,3-butanediol and glycerine; esters of polyhydric alcohols, such as glycerol mono-, di- or triacetate; and aliphatic esters of mono-, di- or polycarboxylic acids, such as dimethyl dodecanedioate and dimethyl tetradecanedioate. The liquid aerosol-forming substrate may comprise water, solvents, ethanol, plant extracts and natural or artificial flavours.

[0038] The liquid aerosol-forming substrate may comprise nicotine and at least one aerosol-former. The aerosol-former may be glycerine or propylene glycol. The aerosol former may comprise both glycerine and propylene glycol. The liquid aerosol-forming substrate may have a nicotine concentration of between about 0.5% and about 10%, for example about 2%.

[0039] The heater assembly may comprise a susceptor element that is configured to be inductively heated. The, or each, heating element may be a susceptor element.

[0040] As used herein, a "susceptor element" means an element that is heatable by penetration with an alternating magnetic field. A susceptor element is typically heatable by at least one of Joule heating through induction of eddy currents in the susceptor element, and hysteresis losses.

[0041] The use of inductive heating may be particularly advantageous in a system in which a liquid reservoir is unsealed immediately prior to use. As the element that is heated in an inductive heating system, namely the susceptor, does not need to have conductive electrical connections to other components of the system, such as the control circuitry and the power supply.

[0042] The susceptor element of the susceptor assembly may comprise a heating region and at least one mounting region. The heating region is a region of the susceptor element that is configured to be heated to a temperature required to vapourise the aerosol-forming substrate upon penetration by a suitable alternating magnetic field.

[0043] The heating region may comprise a first material that is a magnetic material heatable by penetration with an alternating magnetic field. The term "magnetic material" is used herein to describe a material which is able to interact with a magnetic field, including both paramagnetic and ferromagnetic materials. The first material may be any suitable magnetic material that is heatable by penetration with an alternating magnetic field. In some preferred embodiments, the first material comprises a ferritic stainless steel. Suitable ferritic stainless steels include AISI 400 series stainless steels, such as AISI type 409, 410, 420 and 430 stainless steels.

[0044] In some preferred embodiments, the heating region consists of the first material. However, in other embodiments, the heating region comprises the first material and one or more other materials. Where the heating region comprises the first material and one or more other materials, the heating region may comprise any suitable proportion of the first material. For example, the heating region may comprise at least 10 per cent by weight of the first material, or at least 20 per cent by weight of the first material, or at least 30 per cent by weight of the first material, or at least 40 per cent by weight of the first material, or at least 50 per cent by weight of the first material, or at least 60 per cent by weight of the first material, or at least 70 per cent by weight of the first material, or at least 80 per cent by weight of the first material, or at least 90 per cent by weight of the first material.

[0045] The at least one mounting region of the susceptor element may be a region of the susceptor element that is configured to contact a heater holder. The at least one mounting region may be in contact with a heater holder. As used herein, the term "contact" means both direct contact and indirect contact. The heating region may be configured to heat to a substantially higher temperature than the mounting region in the presence of an alternating magnetic field. This may be due to material differences between the heating region and the mounting region, geometric differences between the heating region and the mounting region, or both material and geometric differences.

[0046] Preferably, the at least one mounting region is in direct contact with the heater holder. As used herein, the term 'direct contact' means contact between two components without any intermediate material, such that the surfaces of the two components are touching each other.

[0047] The at least one mounting region may be in indirect contact with the heater holder. As used herein, the term 'indirect contact' is used to mean contact between two components via one or more intermediate materials interposed between the two components, such that the surfaces of the two components are not touching each other. For example, the at least one mounting region is in indirect contact with the susceptor element when a layer of adhesive is provided between a surface of the at least one mounting region and a surface of the heater holder.

[0048] The at least one mounting region may comprise a second material. The second material may be a non-magnetic material. The term "non-magnetic material" is used herein to describe a material which does not interact with a magnetic field, and is not heatable by penetration with an alternating magnetic field. The second material may be any suitable non-magnetic material. In some embodiments, the second material is a non-magnetic metal. For example, the second material may be a non-magnetic austenitic stainless steel. Suitable austenitic stainless steels include AISI 300 series stainless steels, such as AISI type 304, 309 and 316 stainless steels.

[0049] The heater holder may be in contact with the second material at the at least one mounting region of the susceptor element. The heater holder may contact the susceptor element at the second material only. Advantageously, providing contact between the heater holder and the susceptor element at the second material may help to minimise heat transfer from the susceptor element to the heater holder.

[0050] In some embodiments, the second material is non-metallic. For example, the second material may be a ceramic material.

[0051] In some embodiments, the second material is an electrically conductive material. As used herein, an "electrically conductive" material means a material having a volume resistivity at 20 degrees Celsius ($^{\circ}\text{C}$) of less than about 1×10^{-5} ohm-metres (Ωm), typically between about 1×10^{-5} ohm-metres (Ωm) and about 1×10^{-9} ohm-metres (Ωm). Suitable electrically conductive materials include metals, alloys, electrically conductive ceramics and electrically conductive polymers. Suitable electrically conductive materials may include gold and platinum.

[0052] In some embodiments, the second material is an electrically insulative material. Advantageously an electrically insulative second material may help to minimise heat transfer from the susceptor element to the heater holder. As used herein, an "electrically insulating" material means a material having a volume resistivity at 20 degrees Celsius ($^{\circ}\text{C}$) of greater than about 1×10^6 ohm-metres (Ωm), typically between about 1×10^9 ohm-metres (Ωm) and about 1×10^{21} ohm-metres (Ωm). Suitable electrically insulating materials include glasses, plastics and certain ceramic materials.

[0053] In some embodiments, the second material is a thermally insulative material. Advantageously a thermally insulative second material may help to minimise heat transfer from the susceptor element to the heater holder. As used herein, the term "thermally insulative" refers to a material having a bulk thermal conductivity of less than about 5 Watts per metre Kelvin ($\text{mW}/(\text{m K})$) at 23°C and a relative humidity of 50% as measured using the modified transient plane source (MTPS) method.

[0054] In some embodiments, the second material is a thermally conductive material. As used herein, the term "thermally conductive" refers to a material having a bulk thermal conductivity of at least about 10 Watts per metre

Kelvin ($\text{mW}/(\text{m K})$) at 23°C and a relative humidity of 50% as measured using the modified transient plane source (MTPS) method.

[0055] In some embodiments, the second material may be a hydrophilic material. In some embodiments, the second material may be an oleophilic material. Advantageously, providing a hydrophilic second material or an oleophilic second material may encourage the transport of the aerosol-forming substrate through the susceptor element.

[0056] In some embodiments, the second material comprises a cellulosic material. For example, the second material may comprises rayon.

[0057] In some preferred embodiments, the at least one mounting region consists of the second material. However, in other embodiments, the at least one mounting region comprises the second material and one or more other materials. Where the at least one mounting region comprises the second material and one or more other materials, the at least one mounting region may comprise any suitable proportion of the second material. For example, the at least one mounting region of the susceptor element may comprise: at least 10 per cent by weight of the second material, or at least 20 per cent by weight of the second material, or at least 30 per cent by weight of the second material, or at least 40 per cent by weight of the second material, or at least 50 per cent by weight of the second material, or at least 60 per cent by weight of the second material, or at least 70 per cent by weight of the second material, or at least 80 per cent by weight of the second material, or at least 90 per cent by weight of the second material.

[0058] The at least one mounting region may comprise the first material. However, the at least one mounting region comprises a lower proportion of the first material than the heating region. The proportion by weight of the first material in the heating region may be greater than the proportion by weight of the first material in the at least one mounting region. For example: the heating region of the susceptor element may comprise at least 90 percent by weight of the first material, and the at least one mounting region of the susceptor element may comprise less than 10 percent by weight of the first material, or the heating region of the susceptor element may comprise at least 80 percent by weight of the first material, and the at least one mounting region of the susceptor element may comprise less than 20 percent by weight of the first material, or the heating region of the susceptor element may comprise at least 70 percent by weight of the first material, and the at least one mounting region of the susceptor element may comprise less than 30 percent by weight of the first material, or the heating region of the susceptor element may comprise at least 60 percent by weight of the first material, and the at least one mounting region of the susceptor element may comprise less than 40 percent by weight of the first material, or the heating region of the susceptor element may comprise at least 50 percent by weight of the first material, and the at least

one mounting region of the susceptor element may comprise less than 50 percent by weight of the first material.

[0059] The at least one mounting region may comprise: 90 per cent or less by weight of the first material, or 80 per cent or less by weight of the first material, or 70 per cent or less by weight of the first material, or 60 per cent or less by weight of the first material, or 50 per cent or less by weight of the first material, or 40 per cent or less by weight of the first material, or 30 per cent or less by weight of the first material, or 20 per cent or less by weight of the first material, or 10 per cent or less by weight of the first material.

[0060] The at least one mounting region may comprise: at least 10 percent by weight of the second material, and less than 90 percent by weight of the first material, or at least 20 percent by weight of the second material, and less than 80 percent by weight of the first material, or at least 30 percent by weight of the second material, and less than 70 percent by weight of the first material, or at least 40 percent by weight of the second material, and less than 60 percent by weight of the first material, or at least 50 percent by weight of the second material, and less than 50 percent by weight of the first material, or at least 60 percent by weight of the second material, and less than 40 percent by weight of the first material, or at least 70 percent by weight of the second material, and less than 30 percent by weight of the first material, or at least 80 percent by weight of the second material, and less than 20 percent by weight of the first material, or at least 90 percent by weight of the second material, and less than 10 percent by weight of the first material.

[0061] The heating region may comprise the second material. For example, the heating region may comprise: 90 per cent or less by weight of the second material, or 80 per cent or less by weight of the second material, or 70 per cent or less by weight of the second material, or 60 per cent or less by weight of the second material, or 50 per cent or less by weight of the second material, or 40 per cent or less by weight of the second material, or 30 per cent or less by weight of the second material, or 20 per cent or less by weight of the second material, or 10 per cent or less by weight of the second material.

[0062] The heating region may comprise: at least 10 percent by weight of the first material, and less than 90 percent by weight of the second material, or at least 20 percent by weight of the first material, and less than 80 percent by weight of the second material, or at least 30 percent by weight of the first material, and less than 70 percent by weight of the second material, or at least 40 percent by weight of the first material, and less than 60 percent by weight of the second material, or at least 50 percent by weight of the first material, and less than 50 percent by weight of the second material, or at least 60 percent by weight of the first material, and less than 40 percent by weight of the second material, or at least 70 percent by weight of the first material, and less than 30 percent by weight of the second material, or at least 80 percent by weight of the first material, and less than 20

percent by weight of the second material, or at least 90 percent by weight of the first material, and less than 10 percent by weight of the second material.

[0063] The heating region may comprise any suitable proportion of the susceptor element. For example, the heating region may comprise at least 90 per cent of the surface area of the susceptor element, at least 80 per cent of the surface area of the susceptor element, or at least 70 per cent of the surface area of the susceptor element. The heating region may have any suitable size and shape for heating aerosol-forming substrate at the required rate to generate the desired amount of inhalable aerosol.

[0064] The at least one mounting region may comprise any suitable proportion of the susceptor element. Typically the at least one mounting region comprises a smaller proportion of the susceptor element than the heating region. For example, the at least one mounting region may comprise 10 per cent or less of the surface area of the susceptor element, or 20 percent or less of the surface area of the susceptor element. The at least one mounting region may have any suitable size and shape for providing a robust connection between the susceptor element and the heater holder.

[0065] In some embodiments, the at least one mounting region is located adjacent a periphery of the heating region, wherein the heating region has a length and a width, and the at least one mounting region has a length and a width. Preferably, the length of the at least one mounting region is less than the length of the heating region. In some embodiments, the length of the at least one mounting region is no more than half of the length of the heating region. In some embodiments, the length of the at least one mounting region is no more than a quarter of the length of the heating region. Preferably, the width of the at least one mounting region is less than the width of the heating region. In some embodiments, the width of the at least one mounting region is no more than half of the width of the heating region. In some embodiments, the width of the at least one mounting region is no more than a quarter of the width of the heating region.

[0066] In some embodiments, the at least one mounting region is fixed to a heater holder. The at least one mounting region may be fixed to a heater holder by an adhesive.

[0067] The at least one mounting region of the susceptor element may be arranged at any suitable position relative to the heating region of the susceptor element. In some preferred embodiments, the at least one mounting region of the susceptor element is at a periphery of the susceptor element. For example, the at least one mounting region may be located at one side of the susceptor element.

[0068] In some preferred embodiments, the at least one mounting region comprises a plurality of mounting regions. The susceptor element may comprise any suit-

able number of mounting regions. For example, the susceptor element may comprise one, two, three, four, five, or six mounting regions. Advantageously, providing the susceptor element with a plurality of mounting regions may enable the heater holder to provide more robust support to the susceptor element compared to a susceptor element having a single mounting region.

[0069] In some embodiments, the plurality of mounting regions may comprise a first mounting region, and a second mounting region, the first mounting region being positioned at one side of the susceptor element, and the second mounting region being positioned at the same side of the susceptor element as the first mounting region. In some of these embodiments, the first mounting region is positioned at a first end of the susceptor element, and the second mounting region is positioned at a second end of the susceptor element, opposite the first end.

[0070] In some embodiments, the plurality of mounting regions comprises a first mounting region and a second mounting region, the first mounting region being positioned at a first side of the susceptor element, and the second mounting region being positioned at a second side of the susceptor element, opposite to the first side. In some of these embodiments, the heating region has a length, and the first mounting region and the second mounting region are positioned at the same position along the length of the heating region. In some of these embodiments, the first mounting region and the second mounting region are positioned at one end of the susceptor element. In some of these embodiments, the heating region has a length, and the first mounting region and the second mounting region are positioned centrally along the length of the heating region. In some of these embodiments, the heating region has a length, and the first mounting region and the second mounting region are positioned at different positions along the length of the heating region. In some of these embodiments, the first mounting region is positioned at a first end of the susceptor element, and the second mounting region is positioned at a second end of the susceptor element, opposite to the first end.

[0071] In some preferred embodiments, the plurality of mounting regions comprises a first mounting region and a second mounting region, the second mounting region being positioned opposite the first mounting region.

[0072] In some preferred embodiments, the plurality of mounting regions comprises: a first pair of mounting regions positioned at a first end of the susceptor element, at opposite sides of the susceptor element; and a second pair of mounting regions positioned at a second end of the susceptor element at opposite sides of the susceptor element, the second end of the susceptor element being opposite the first end.

[0073] In some embodiments, the plurality of mounting regions comprises a plurality of pairs of mounting regions, each pair of mounting regions including a first mounting region positioned at a first side of the susceptor element, and a second mounting region positioned at a

second side of the susceptor element, the second side of the susceptor element being opposite the first side of the susceptor element.

[0074] In some embodiments, the plurality of mounting regions comprises a plurality of pairs of mounting regions, each pair of mounting regions including a first mounting region and a second mounting region, the second mounting region being positioned opposite the first mounting region.

[0075] The thickness of the susceptor element is advantageously between 2 and 10 times the skin depth of the material of the susceptor element at the frequency of operation of the system. When multiple susceptor layers are used, having a thickness greater than the skin depth minimises interaction between different susceptor layers. Having the susceptor layers less than 10 times the skin depth ensures that there is not an excessive mass of susceptor material to heat. Advantageously the susceptor or heating element assembly has a thickness of no greater than 2 millimetres. This allows the heating element or elements to be placed inside and to span a small airflow channel.

[0076] The, or each, heating element may be a resistively heated heating element. The heater assembly may comprise a plurality of electrical connectors connected to the, or each, heating element and configured for connection to a power supply in another component of the aerosol-generating system. The electrical connector may comprise a connection surface accessible from an exterior of the cartridge. The connection surface may be part of the engagement surface.

[0077] The resistively heated heating element may comprise a mounting region and a heating region, as described above in relation to a susceptor element, wherein, in use, the heating region is heated to a higher temperature than the mounting region. The heating region may comprise different materials to the mounting region. The heating region may have a different geometry to the mounting region. The heating region may be positioned between two electrical connectors.

[0078] The, or each, heating element may take any suitable form. The heating element may comprise, for example, a mesh, flat spiral coil, fibres or a fabric. In some embodiments, the heating element may comprise a sheet or a strip.

[0079] Advantageously the heater assembly is configured to hold only a small volume of liquid aerosol-forming substrate, sufficient for a single user puff. This is advantageous because it allows that small volume of liquid to be vaporised rapidly, with minimal heat loss to other elements of the system or to liquid aerosol-forming substrate that is not vaporised. Advantageously, the heater assembly may hold between 2 millilitres and 10 millilitres of liquid aerosol-forming substrate.

[0080] At least a portion of the heating element may be fluid permeable. In some embodiments, the heating element is fluid permeable. As used herein a "fluid permeable" element means an element that allows liquid or

gas to permeate through it. The heating element may have a plurality of openings formed in it to allow fluid to permeate through it. In particular, the heating element may allow the aerosol-forming substrate, in either gaseous phase or both gaseous and liquid phase, to permeate through it.

[0081] In some preferred embodiments, the, or each, heating element may comprise a mesh. The heating element may comprise an array of filaments forming a mesh. As used herein the term "mesh" encompasses grids and arrays of filaments having spaces therebetween. The term mesh also includes woven and non-woven fabrics.

[0082] The filaments may define interstices between the filaments and the interstices may have a width of between 10 micrometres and 100 micrometres. Preferably the filaments give rise to capillary action in the interstices, so that in use, the source liquid is drawn into the interstices, increasing the contact area between the heating element and the liquid.

[0083] The filaments may form a mesh of size between 160 and 600 Mesh US (+/- 10%) (i.e. between 160 and 600 filaments per inch (+/- 10%)). The width of the interstices may be between 35 micrometres and 140 micrometres, or between 25 micrometres and 75 micrometres. For example, the width of the interstices may be 40 micrometres, or 63 micrometres. The percentage of open area of the mesh, which is the ratio of the area of the interstices to the total area of the mesh is preferably between 25 and 56%. The mesh may be formed using different types of weave or lattice structures. Alternatively, the filaments consist of an array of filaments arranged parallel to one another.

[0084] The filaments may be formed by etching a sheet material, such as a foil. This may be particularly advantageous when the heater assembly comprises an array of parallel filaments. If the heating element comprises a mesh or fabric of filaments, the filaments may be individually formed and knitted together.

[0085] Preferably, the mesh is sintered. Advantageously, sintering the mesh creates electrical bonds between filaments extending in different directions. In particular, where the mesh comprises one or more of woven and non-woven fabrics, it is advantageous for the mesh to be sintered to create electrical bonds between overlapping filaments.

[0086] The mesh may also be characterised by its ability to retain liquid, as is well understood in the art.

[0087] The filaments of the mesh may have a diameter of between 8 micrometres and 100 micrometres, between 30 micrometres and 100 micrometres, between 8 micrometres and 50 micrometres, or between 8 micrometres and 39 micrometres. The filaments of the mesh may have a diameter of 50 micrometres.

[0088] The filaments of the mesh may have any suitable cross-section. For example, the filaments may have a round cross section or may have a flattened cross-section.

[0089] Advantageously, in embodiments in which the heating element is a susceptor element, the mesh may have a relative permeability between 1 and 40000. When a reliance on eddy currents for a majority of the heating is desirable, a lower permeability material may be used, and when hysteresis effects are desired then a higher permeability material may be used. Preferably, the material has a relative permeability between 500 and 40000. This may provide for efficient heating of the susceptor element.

[0090] Where the heating element comprises a mesh, the heating region may comprise filaments of the first material. In some embodiments, the heating region may comprise filaments of the first material and filaments of the second material. The heating region may comprise filaments of the first material in a first direction, and filaments of the second material in a second direction, different to the first direction.

[0091] Where the heating element comprises a mesh, the at least one mounting region may comprise filaments of the second material. In some embodiments, the at least one mounting region may comprise filaments of the first material and filaments of the second material. The at least one mounting region may comprise filaments of the first material in a first direction, and filaments of the second material in a second direction, different to the first direction.

[0092] Where the heating element comprises a mesh, the mesh may be woven. A woven mesh comprises filaments in a weft direction, and filaments in a warp direction.

[0093] Where the heating element comprises a woven mesh, at least one mounting region may comprise filaments of the second material in a weft direction. The heater holder may be in contact the heating element at the at least one mounting region at filaments extending in the weft direction. The heater holder may be in contact the heating element at the at least one mounting region at filaments extending in the weft direction only, and not in contact with filaments extending in the warp direction. Advantageously, forming the filaments of the at least one mounting region that extend in the weft direction from the second material may reduce heat transfer from the heating element to the heater holder compared to a heating element having filaments in the weft direction at the at least one mounting region formed from the first material.

[0094] Advantageously, the cartridge comprising an airflow channel through the cartridge, extending from an air inlet, past the heating element to an air outlet when the heater assembly is in the second position. The air outlet may be in a mouthpiece portion of the outer housing. The airflow channel may pass through the heater assembly. In particular, the airflow channel may pass through the heater holder.

[0095] A portion of the heater assembly, and in particular the heating element, may be within the airflow passage. A heating region of the heating element may be within the airflow passage. Aerosol-forming substrate va-

porised by the heating element may escape into the airflow passage. The vapour may condense to form an aerosol within the airflow passage. The aerosol may be drawn out of the aerosol-generating system through the air outlet. The air outlet may be provided in a mouth end of the aerosol-generating system, through which generated aerosol can be drawn by a user.

[0096] The heating element or heating elements, or susceptor assembly, may have a first surface parallel to the first plane and a second surface parallel to the first plane, opposing the first surface, wherein at least a portion of both the first and second surfaces are in direct contact with air in the airflow passage. Advantageously, the airflow passage extends parallel to the first plane in a vicinity of the heating element or heating elements.

[0097] A first side of the heating element may face the mouth end and a second side of the heating element may face the connection end. However, preferably, the heating element is planar and extends in a plane that is substantially parallel to a longitudinal axis of the cartridge, extending between the mouth end and the connection end. Where the planar heating element extends in a plane that is substantially parallel to a longitudinal axis of the cartridge, the first and second sides of the heating element face opposite sides of the system.

[0098] The liquid reservoir may surround a portion of the airflow channel. The airflow passage may pass through the liquid reservoir. For example, the liquid reservoir may have an annular cross-section defining an internal passage, and the airflow passage may extend through the internal passage of the liquid reservoir.

[0099] Where the heater holder is a tubular heater holder, the internal passage of the tubular heater holder may form a portion of the enclosed airflow passage. The enclosed airflow passage may extend from the air inlet at the connection end of the cartridge, through the internal passage of the tubular heater holder, through the internal passage of the liquid reservoir to the air outlet at the mouth end opening.

[0100] In some embodiments, at least a portion of the airflow passage is defined between the heater holder and an outer housing of the cartridge. At least a portion of the airflow passage may be defined between the liquid reservoir and the outer housing of the cartridge. In some embodiments, the enclosed airflow passage may extend from the air inlet, through a passage between the heater holder and the outer housing, through a passage between the liquid reservoir and the outer housing to the air outlet.

[0101] The present disclosure also provides an aerosol generating system comprising a cartridge as described above and a reusable device that is configured to couple to, or engage with, the cartridge, wherein the reusable device may comprise a power supply for providing energy to the heating element. The cartridge is one component of the aerosol generating system and the reusable device is another component of the aerosol generating system. The aerosol generating system may consist

of the cartridge and the reusable device.

[0102] The reusable device may comprise a housing. The housing may be elongate. The housing may comprise any suitable material or combination of materials. Examples of suitable materials include metals, alloys, plastics or composite materials containing one or more of those materials, or thermoplastics that are suitable for food or pharmaceutical applications, for example polypropylene, polyetheretherketone (PEEK) and polyethylene. The material is preferably light and non-brittle.

[0103] The aerosol generating system may be configured so that the heater assembly is moved from the first position to the second position as a consequence of the cartridge being coupled to the reusable device. The reusable device may comprise a contact surface that engages an engagement surface on the heating assembly when the cartridge is coupled to the reusable device to urge the heater assembly into the second position, the engagement surface on the heating assembly facing away from the reservoir.

[0104] In embodiments employing resistive heating, the contact surface may include electrical contacts configured to engage with corresponding electrical connectors on the cartridge. Electrical power may be delivered to the heating element through the electrical contacts and electrical contacts when the cartridge and reusable device are engaged with one another.

[0105] The reusable device housing may define a cavity for receiving at least a portion of the cartridge. The reusable device may comprise one or more air inlets. The one or more air inlets may enable ambient air to be drawn into the cavity.

[0106] The reusable device may have a connection end configured to connect the reusable device to a cartridge. The connection end may comprise a cavity for receiving at least a portion of the cartridge.

[0107] The reusable device may have a distal end, opposite the connection end. The distal end may comprise an electrical connector configured to connect the aerosol-generating device to an electrical connector of an external power source, for charging the power source of the aerosol-generating device.

[0108] In embodiments configured for inductive heating, the reusable portion comprises one or more inductor coils configured to generate a variable magnetic flux through the heating element. The one or more inductor coils may be arranged outside the cavity. The cavity may be open at connection end. The contact surface may be at the distal end of the cavity. At least one of the inductor coils may be a planar inductor coil and the susceptor element may be planar and arranged parallel to the planar induction coil when the reusable device is engaged with the cartridge.

[0109] The cartridge housing may comprise an outer housing. The outer housing may be formed from a durable material. The outer housing may be formed from a liquid impermeable material. The outer housing may be formed from a mouldable plastics material, such as poly-

propylene (PP) or polyethylene terephthalate (PET). The outer housing may be formed from the same material as the heater holder or may be formed from a different material.

[0110] The heater assembly may be arranged in the outer housing. The heater holder may be arranged in the outer housing. In some embodiments, the heater holder may be integrally formed with the outer housing.

[0111] The outer housing may define a portion of the liquid reservoir. The outer housing may define the liquid reservoir. The outer housing and the liquid reservoir may be integrally formed. Alternatively, the liquid reservoir may be formed separately from the outer housing, and arranged in the outer housing.

[0112] Advantageously, providing the cartridge with a heater holder that couples the heating element to the housing may separate the heating element from the outer housing, such that the outer housing is not required to be configured to withstand the temperatures to which the heating element is raised for heating of the aerosol-forming substrate. This may enable the cartridge to be made from less durable and less expensive materials.

[0113] The aerosol-generating system may be a handheld aerosol-generating system configured to allow a user to puff on a mouthpiece to draw an aerosol through a mouth end opening. The aerosol-generating system may have a size comparable to a conventional cigar or cigarette. The aerosol-generating system may have a total length between about 30 millimetres and about 150 millimetres. The aerosol-generating system may have an external diameter between about 5 millimetres and about 30 millimetres.

[0114] The aerosol-generating system may be configured to deliver nicotine or cannabinoids to a user. The aerosol-generating system may be an electrically operated smoking device.

[0115] The aerosol-generating system may comprise control circuitry. The control circuitry may be in the reusable device. The control circuitry may comprise a microprocessor. The microprocessor may be a programmable microprocessor, a microcontroller, or an application specific integrated chip (ASIC) or other electronic circuitry capable of providing control. The control circuitry may be configured to supply power to the at least one inductor coil or to the heating element continuously following activation of the device or may be configured to supply power intermittently, such as on a puff-by-puff basis. The power may be supplied to the heating assembly in the form of pulses of electrical current, for example, by means of pulse width modulation (PWM). The control circuitry may comprise DC/AC inverter, which may comprise a Class-D or Class-E power amplifier. The control circuitry may comprise further electronic components. For example, in some embodiments, the control circuitry may comprise any of: sensors, switches, display elements.

[0116] The aerosol-generating system may comprise a power source. The power source may be contained in the reusable device. The power source may be a DC

power supply. The power source may be a battery. The battery may be a Lithium based battery, for example a Lithium-Cobalt, a Lithium-Iron-Phosphate, a Lithium Titanate or a Lithium-Polymer battery. The battery may be a Nickel-metal hydride battery or a Nickel cadmium battery. The power source may be another form of charge storage device such as a capacitor. The power source may be rechargeable and be configured for many cycles of charge and discharge. The power source may have a capacity that allows for the storage of enough energy for one or more user experiences of the aerosol-generating system; for example, the power source may have sufficient capacity to allow for the continuous generation of aerosol for a period of around six minutes, corresponding to the typical time taken to smoke a conventional cigarette, or for a period that is a multiple of six minutes. In another example, the power source may have sufficient capacity to allow for a predetermined number of puffs or discrete activations of the atomiser assembly.

[0117] The present disclosure additionally provides an aerosol generating system comprising: a housing containing a sealed liquid reservoir; a heater assembly within the outer housing, the heater assembly comprising a heating element and a piercing element, and wherein the heater assembly is movable relative to the outer housing from a first position in which the piercing element is remote from the sealed liquid reservoir to a second position in which the piercing element penetrates the liquid reservoir; and a power supply for providing energy to the heating element.

[0118] In this aspect, the heater assembly may be provided in a reusable part of the system rather than in a replaceable cartridge. The sealed liquid reservoir may be provided as a replaceable component, separate to the other components of the system, such as the heater assembly.

[0119] The system may comprise any one or more of the features of the cartridge and system described above. For example, the aerosol generating system may comprise one or more inductor coils configured to generate a variable magnetic flux through the heating element. At least one of the inductor coils may be a planar inductor coil and the susceptor element may be planar and arranged parallel to the planar induction coil. The sealed liquid reservoir may be a separate and replaceable component of the system.

[0120] The present disclosure additionally provides cartridge for an aerosol-generating device, comprising: a housing containing a sealed liquid reservoir; a heater assembly within the housing, the heater assembly comprising a susceptor element configured to be heated by penetration of a variable magnetic field and a piercing element, and wherein the heater assembly is movable relative to the sealed liquid reservoir from a first position in which the piercing element is remote from the sealed liquid reservoir to a second position in which the piercing element penetrates the liquid reservoir. In this cartridge, either, or both, of the heater assembly and the liquid res-

ervoir may move relative to the housing to move from the first position to the second position.

[0121] The cartridge may comprise any one or more of the features of the cartridge described above. For example, the heater assembly may comprise a transport material for conveying liquid from to a heating surface of the susceptor when the heater assembly is in the second position.

[0122] It will be appreciated that any features described herein in relation to one embodiment of a cartridge or an aerosol-generating device may also be applicable to other embodiments of cartridges and aerosol-generating devices according to this disclosure. A feature described in relation to one embodiment may be equally applicable to another embodiment in accordance with this disclosure. It will also be appreciated that an aerosol-generating system according to this disclosure may be provided in an aerosol-generating device without a cartridge. Accordingly, any of the features described herein with relation to a cartridge may be equally applicable to an aerosol-generating device.

[0123] Examples will now be further described with reference to the figures in which:

Figure 1a shows a schematic illustration of an aerosol-generating system according to an example of the present disclosure;

Figure 1b shows a schematic illustration of the aerosol-generating system of Figure 1a rotated by 90 degrees about a central longitudinal axis of the aerosol-generating system;

Figure 2a shows a schematic illustration of a cartridge for the aerosol-generating system of Figures 1a and 1b;

Figure 2b shows a schematic illustration of the cartridge of Figure 2a rotated by 90 degrees about a central longitudinal axis of the cartridge;

Figure 2c shows a schematic illustration of the cartridge of Figure 2a, wherein the cartridge is in a use configuration;

Figure 3a shows a side view of a susceptor assembly of the cartridge of Figures 1a and 1b;

Figure 3b shows a perspective view of the susceptor assembly of Figure 3a;

Figure 3c shows a plan view of the susceptor assembly of Figure 3a;

Figure 4a is a perspective view of a heater assembly according to an example of the present invention;

Figure 4b is a cross-section of the heater assembly of Figure 3b;

Figure 5a is a partial view of a cartridge including a heater assembly as shown in Figure 3a, in a first prior to use;

Figure 5b is a partial view of a cartridge including a heater assembly as shown in Figure 3a, in a second ready for use;

Figure 6a shows a schematic illustration of a cartridge for an aerosol-generating system in accord-

ance with another example of the present disclosure, wherein the cartridge is in a storage configuration; Figure 6b shows a schematic illustration of the cartridge of Figure 6a, wherein the cartridge is in a use configuration;

Figure 7a shows a schematic illustration of an aerosol-generating system according to a second example of the present disclosure, the aerosol-generating system comprising the cartridge of Figures 6a and 6b received in an aerosol-generating device; Figure 7b shows a schematic illustration of the aerosol-generating system of Figure 7a rotated by 90 degrees about a central longitudinal axis of the aerosol-generating system;

Figure 8a shows a schematic illustration of an aerosol-generating system according to another example of the present disclosure;

Figure 8b shows a schematic illustration of the aerosol-generating system of Figure 8a rotated by 90 degrees about a central longitudinal axis of the aerosol-generating system;

Figure 9a shows a schematic illustration of a cartridge for the aerosol-generating system of Figures 8a and 8b;

Figure 9b shows a schematic illustration of the cartridge of Figure 9a rotated by 90 degrees about a central longitudinal axis of the cartridge; and

Figure 9c shows a schematic illustration of the cartridge of Figure 9a, wherein the cartridge is in a use configuration.

[0124] Figure 1a shows a schematic illustration of an aerosol-generating system according to an example of the present disclosure. Figure 1b shows a schematic illustration of the aerosol-generating system of Figure 1a rotated by 90 degrees about a central longitudinal axis of the aerosol-generating system. The system comprises a cartridge 10 and a device 60, which are coupled together to form the aerosol-generating system. The aerosol-generating system is portable and has a size comparable to a conventional cigar or cigarette.

[0125] The cartridge 10 is shown alone in Figures 2a, 2b and 2c. Figure 2a shows the cartridge with the heater assembly in a first position, prior to use. Figure 2b shows the cartridge rotated by 90 degrees about a central longitudinal axis of the cartridge. Figure 2c shows the cartridge in a use configuration, where the heater assembly has moved to the second position.

[0126] The cartridge 10 comprises a heater assembly comprising a susceptor assembly mounted in a heater holder. The susceptor assembly 12 is shown in more detail in Figures 3a, 3b and 3c. The susceptor assembly 12 is planar, and thin, having a thickness dimension that is substantially smaller than a length dimension and a width dimension. The susceptor assembly 12 is shaped in the form of a cross, and comprises three layers, a first susceptor element 16, a second susceptor element 18, and a wicking element 20 arranged between the first and

second susceptor elements 16, 18. Each of the first susceptor element 16, the second susceptor element 18, and the wicking element 20 generally forms the shape of a cross, and each element has the same length and width dimensions. The first and second susceptor elements 16, 18 are substantially identical, and comprise a sintered mesh formed from ferritic stainless steel filaments and austenitic stainless steel filaments, as described in more detail below. The wicking element 20 comprises a porous body of rayon filaments. The wicking element 20 is configured to deliver liquid from the outer, exposed surfaces of the wicking element 20 to the first and second susceptor elements 16, 18.

[0127] Each of the first and second susceptor elements 16, 18 comprises a pair of mounting regions 22 and a heating region 24. The heating region 24 is a substantially rectangular region located centrally on the susceptor elements 16, 18. The pair of mounting regions 22 are also substantially rectangular regions located at the periphery of the heating region 24, at opposite sides of the heating region 24. In this embodiment, the mounting regions 22 are arranged at the same central position along the length of the heating region 24.

[0128] Each of the pair of mounting regions 22 has a smaller surface area than the heating region 24. The length l_m of each of the mounting regions 22 is less than the length l_h of the heating region 24, and the width w_m of each of the mounting regions 22 is less than the width w_h of the heating region 24. In this embodiment, the heating region 24 has a length l_h of about 6.50 millimetres, and a width w_h of about 3.50 millimetres, and each of the mounting regions 22 has a length l_m of about 2.50 millimetres, and a width w_m of about 1.15 millimetres. As such, each of the first and second susceptor elements 16, 18 has a total maximum length of about 6.50 millimetres, and a total maximum width of about 5.80 millimetres.

[0129] The heating region 24 is configured to be heatable by penetration with an alternating magnetic field, for vapourising an aerosol-forming substrate. The pair of mounting regions 22 are configured to contact the heater holder 14, such that the heater holder 14 can support the susceptor assembly 12 in position in the cartridge 10. The pair of mounting regions 22 are configured to minimise heat transfer from the susceptor assembly 12 to the heater holder 14.

[0130] Each of the first and second susceptor elements 16, 18 comprises a mesh having filaments extending in a first direction, and filaments extending in a second direction, substantially perpendicular to the first direction. The heating region 24 comprises filaments of AISI 410 stainless steel, a ferritic stainless steel, extending in both the first and second directions. The pair of mounting regions 22 comprise filaments of AISI 410 stainless steel extending in the first direction, and filaments of AISI 316 stainless steel, an austenitic stainless steel, extending in the second direction. Accordingly, the heating region 24 is comprised of a magnetic material, and the pair of mounting regions 22 are in part comprised of a magnetic

material, and in part comprised of a non-magnetic material. The proportion by weight of the AISI 410 stainless steel in the heating region 24 is greater than the proportion by weight of the AISI 410 in each of the pair of mounting regions 22.

[0131] Providing the first and second susceptor elements 16, 18 with mounting regions 22 having a reduced cross-section compared to the heating region 24, and at least partially comprising the mounting regions 22 from a non-magnetic material helps to reduce heating of the mounting regions 22 when the susceptor elements are penetrated by an alternating magnetic field. Such a configuration also helps to reduce heat transfer from the susceptor assembly 12 to the heater holder 14.

[0132] It will be appreciated that in other embodiments the heating region 24 and the pair of mounting regions 22 may be formed from other combinations of magnetic and non-magnetic materials. For example, in some embodiments the heating region 24 comprises filaments of AISI 410 stainless steel, a ferritic stainless steel, extending in the first direction, and filaments of AISI 316 stainless steel, an austenitic stainless steel, extending in the second directions. In these embodiments, the pair of mounting regions 22 may comprise filaments of AISI 316 stainless steel extending in both the first and second directions. Accordingly, in these embodiments, the heating region 24 is in part comprised of a magnetic material, and in part comprised of a non-magnetic material, and the pair of mounting regions 22 consist of a non-magnetic material.

[0133] The heater holder 14 comprises a tubular body formed from a mouldable plastic material, such as polypropylene. The tubular body of the heater holder 14 comprises a side wall defining an internal passage 26, having open ends. A pair of openings 28 extend through the side wall, at opposite sides of the tubular heater holder 14. The openings 28 are arranged centrally along the length of the heater holder 14.

[0134] The susceptor assembly 12 is arranged inside the internal passage 26 of the tubular heater holder 14, and extends in a plane parallel to a central longitudinal axis of the heater holder 14. The heating region 24 of the first and second susceptor elements 16, 18 is arranged entirely within the internal passage 26 of the heater holder 14, and each of the mounting regions 22 extends through one of the openings 28 in the side wall of the heater holder 14. The openings 28 in the side wall of the heater holder 14 are sized to accommodate the susceptor assembly 12 with a friction fit, such that the susceptor assembly is secured in the heater holder 14. The friction fit between the susceptor assembly 12 and the heater holder 14 results in the mounting regions 22 directly contacting the heater holder 14 at the openings 28. The susceptor assembly 12 and the heater holder 14 are secured together such that movement of the heater holder 14 also moves the susceptor assembly 12.

[0135] It will be appreciated that the susceptor assembly 12 and the heater holder 14 may be secured together

by other means. For example, in some embodiments the susceptor assembly 12 is secured to the heater holder 14 by an adhesive at the mounting regions 22 of the susceptor assembly 12, such that the mounting regions 22 indirectly contact the heater holder 14.

[0136] The heater holder 14 comprises a base 30 that partially closes one end of the internal passage 26. The base 30 comprises a plurality of air inlets 32 that enable air to be drawn into the internal passage 26 through the partially closed end.

[0137] The heater holder 14 further comprises a pair of piercing elements 34 extending from an outer surface of the side wall, towards the open end of the heater holder 14 opposite the end partially closed by the base 30. The openings 28 in the sidewall of the heater holder 14 are arranged between the piercing elements 34 around the circumference of the side wall, such that the piercing elements 34 are offset from the openings 28 around the circumference of the side wall of the tubular heater holder by about 90 degrees. Each of the piercing elements 34 comprises hollow spike facing in the direction of the open end of the heater holder 14.

[0138] The cartridge 10 further comprises an outer housing 36 formed from a mouldable plastics material, such as polypropylene. The outer housing 36 generally forms a hollow cylinder, defining an internal space in which the susceptor assembly 12 and the heater holder 14 are contained.

[0139] The outer housing 36 forms a first portion of the cartridge 10, and the susceptor assembly 12 and the heater holder 14 form a second portion of the cartridge 10. The second portion of the cartridge is slidable relative to the first portion of the cartridge between a storage configuration, as shown in Figures 2a and 2b, and a use configuration, as shown in Figure 2c.

[0140] The cartridge 10 has a mouth end, and a connection end, opposite the mouth end. The outer housing 36 defines a mouth end opening 38 at the mouth end of the cartridge 10. The connection end is configured for connection of the cartridge 10 to an aerosol-generating device, as described in detail below. The susceptor assembly 12 and the heater holder 14 are located towards the connection end of the cartridge 10. The external width of the outer housing 36 is greater at the mouth end of the cartridge 10 than at the connection end, which are joined by a shoulder 37. This enables the connection end of the cartridge to be received in a cavity of an aerosol-generating device, with the shoulder 37 locating the cartridge in the correct position in the device. This also enables the mouth end of the cartridge 10 to remain outside of the aerosol-generating device, with the mouth end conforming to the external shape of the aerosol-generating device.

[0141] A liquid reservoir 44 is defined in the cartridge for holding a liquid aerosol-forming substrate 42. The liquid reservoir 44 is located towards the mouth end of the outer housing 36, and comprises an annular space defined by the outer housing 36. The annular space has an

internal passage 48 that extends between the mouth end opening 38, and the open end of the internal passage 26 of the heater holder 14. An annular space 46 into which liquid from the reservoir flows after the reservoir has been pierced is located towards the connection end of the outer housing 36, and is defined between an inner surface of the outer housing 36 and an outer surface of the heater holder 14. The base 20 of the tubular heater holder 14 is provided with an annular, ribbed, elastomeric gasket 50 that extends between the outer surface of the tubular susceptor 14 and the internal surface of the outer housing 36. The gasket 50 provides a liquid tight seal between the heater holder 14 and the outer housing 36, ensuring that the second portion 46 of the liquid reservoir 40 is capable of holding the liquid aerosol forming substrate 42.

[0142] The base 30 comprises an engagement surface that engages contact surfaces on protrusions 63 in the cavity 64 of the reusable aerosol generating device, when the cartridge is engaged with the device.

[0143] The liquid reservoir 44 is fluidly isolated from by an aluminium foil seal 52, which is pierceable by the piercing elements 34 of the heater holder to allow liquid aerosol-forming substrate 42 to flow into the space 46 and to the heater assembly, as described in more detail below.

[0144] An air passage is formed through the cartridge 10 by the internal passage 26 of the heater holder 14, and the internal passage 48 through the first portion 44 of the liquid reservoir 40. The air passage extends from the air inlets 32 in the base 30 of the heater holder 14, through the internal passage 26 of the heater holder 14, and through the internal passage 48 of the first portion 44 of the liquid reservoir 40 to the mouth end opening 38. The air passage enables air to be drawn through the cartridge 10 from the connection end to the mouth end.

[0145] In the storage configuration, as shown in Figures 2a and 2b, the base 30 of the heater holder 14 extends out of the outer housing 36, and the piercing elements 34 of the heater holder 14 are spaced from the seal 52 in the direction of the connection end of the cartridge 10. In this configuration, the liquid aerosol-forming substrate 42 is held in the liquid reservoir 44, and is isolated from the space 46 by the seal 52. Accordingly, in the storage configuration the susceptor assembly 12 is isolated from the aerosol-forming substrate 42. Advantageously, sealing the liquid aerosol-forming substrate 42 in the reservoir 44 may entirely prevent the liquid aerosol-forming substrate 42 from leaking out of the cartridge 10 while the cartridge is in the storage configuration.

[0146] In the use configuration, as shown in Figure 2c, the heater holder 14 and the susceptor assembly 12 are pushed into the outer housing 36, towards the mouth end. As the heater holder 14 is pushed towards the mouth end of the outer housing 36 by the engagement with the protrusions 63, the gasket 50 at the base 30 of the heater holder 14 slides over the inner surface of the outer hous-

ing 36, maintaining a liquid tight seal between the inner surface of the outer housing 36 and the outer surface of the tubular heater holder body as the base of the heater holder 14 is received in the outer housing. As the piercing elements 34 of the heater holder 14 are moved towards the mouth end, the piercing elements 34 contact and pierce the seal 52, allowing fluid communication between the liquid reservoir 44, and the space 46. The liquid aerosol-forming substrate 42 in the liquid reservoir 44 is released into the space 46, and the susceptor assembly 12 is exposed to the liquid aerosol-forming substrate 42. In the use configuration, the mounting regions 22 of the first and second susceptor elements 16, 18, and the corresponding portions of the wicking element 20 that extend into the space 46, are able to draw the liquid aerosol-forming substrate 42 from the space 46 to the heating region 24 of the first and second susceptor elements 16, 18. As a result, in the use configuration the cartridge 10 is ready for use to generate an aerosol by heating the aerosol-forming substrate 42.

[0147] The aerosol-generating device 60 comprises a generally cylindrical housing 62 having a connection end and a distal end opposite the connection end. A cavity 64 for receiving the connection end of the cartridge is located at the connection end of the device 60, and an air inlet 65 is provided through the outer housing 62 at the base of the cavity 64 to enable ambient air to be drawn into the cavity 64 at the base.

[0148] The device 60 further comprises an inductive heating arrangement arranged within the housing 62. The inductive heating arrangement includes a pair of inductor coils 66, 68, control circuitry 70 and a power supply 72. The power supply 72 comprises a rechargeable nickel cadmium battery, that is rechargeable via an electrical connector (not shown) at the distal end of the device. The control circuitry 70 is connected to the power supply 72, and to the first and second inductor coils 66, 68, such that the control circuitry 70 controls the supply of power to the inductor coils 66, 68. The control circuitry 70 is configured to supply an alternating current to the first and second inductor coils 66, 68.

[0149] The pair of inductor coils comprises a first inductor coil 66, and a second inductor coil 68. The first inductor coil 66 is arranged at a first side of the cavity 64, and the second inductor coil 68 is arranged at a second side of the cavity 64, opposite the first inductor coil 66. Each of the inductor coils 66, 68 is substantially identical, and comprises a planar coil having a rectangular cross-section, formed from rectangular cross-section wire. Each of the inductor coils 66, 68 extends substantially in a plane, with the first coil 66 extending in a first plane and the second coil 68 extending in a second plane. The first and second planes are substantially parallel to each other, and extend substantially parallel to a central longitudinal axis of the cavity 64 at the connection end of the device 60. When the cartridge 10 is received in the cavity 64, the susceptor assembly 12 is arranged between the first and second inductor coils 66, 68, and the plane of

the susceptor assembly 12 is arranged substantially parallel to the first and second planes.

[0150] Flux concentrators 69 are provided around each of the inductor coils in order to contain and concentrate the magnetic field within the cavity. The flux concentrators 69 may be formed from a magnetic material, such as iron.

[0151] Each of the first and second inductor coils 66, 68 is configured such that when the alternating current is supplied to the inductor coils 66, 68, the inductor coil generates an alternating magnetic field in the cavity 64. The alternating magnetic field generated by each of the inductor coils 66, 68 is directed substantially perpendicular to the plane of the susceptor assembly 12, and the susceptor elements 16, 18.

[0152] The inductive heating arrangement is also configured such that the second inductor coil 68 generates an alternating magnetic field in the cavity 64 that is equal and opposite to the alternating magnetic field generated in the cavity 64 by the first inductor coil 66. In this embodiment, the first and second inductor coils 66, 68 are connected together in series, and are substantially identical, but are wound in opposite senses. In this configuration, the first and second inductor coils 66, 68 generate alternating magnetic fields in the cavity 64 with substantially equal magnitudes, but in substantially opposite directions.

[0153] Figure 4a is a perspective view of a heater holder 14 and susceptor assembly 12. Figure 4b is a cross-section of Figure 4a, rotated through 90 degrees. The heater holder is a moulded plastic component and is generally tubular. The heater holder includes integral hollow piercing elements 34, on opposite sides of the tubular heater holder. The central bore of the heater holder forms part of the airflow passage through the cartridge. The susceptor assembly 12 is arranged generally parallel with the axis of the airflow passage. It can be seen that when the piercing elements 34 penetrate the foil seal of the liquid reservoir, liquid can flow through the hollow piercing elements into the space 46 and from there is drawn into the ends of the susceptor assembly.

[0154] Figure 5a is a perspective view of the heater holder and susceptor assembly of Figures 4a and 4b within a cartridge, in a first position prior to use. Figure 5b shows the cartridge of Figure 5b with the heater assembly pushed into the second position.

[0155] In Figure 5a the base 30 protrudes from the outer housing 36. The piercing elements 34 have not penetrated the foil sealing member 52 and the liquid is retained in reservoir 44

In Figure 5b the base 30 is pushed into the outer housing 36 so that the piercing element 34 have been pushed through the foil sealing member. The liquid in the reservoir then flows into the space 46 and into contact with the susceptor assembly 12.

[0156] It can be seen that this arrangement provides a convenient way to unseal the liquid reservoir just prior to use of the system. The user is not required to perform

any additional actions to unseal the reservoir before they couple the cartridge to the reusable device component.

[0157] It will be appreciated that the sealing member 52, so far described as comprising a foil, could take the form of a plug or septum that seals around the piercing elements when they puncture the sealing member. This may allow an alternative design in which the gasket 50 is not required.

[0158] Figures 6a and 6b show schematic illustrations of a cartridge 10 for an aerosol generating device according to another embodiment of the present disclosure. The cartridge 10 shown in Figure 6a is substantially similar to the cartridge 10 shown in Figures 2a, 2b and 2c, and like features are denoted by like reference numerals.

[0159] The cartridge 10 comprises two susceptor assemblies 12, mounted in a heater holder 14. Each susceptor assembly 12 is planar, and thin, and is shaped in the form of the letter "C". Each susceptor assembly 12 has the same three layered configuration as the susceptor assembly 12 of Figures 3a-3c, having a wicking element arranged between a first and second susceptor element (not shown). Each susceptor element has a rectangular heating region and two mounting regions arranged at one side of the heating region, at opposite ends of the heating region.

[0160] The heater holder 14 comprises a tubular body, comprising a side wall defining an internal passage 26, having open ends. Two pairs of openings 28 extend through the side wall, each pair of openings 28 having one opening located at one side of the heater holder 14, and another opening located at the opposite side of the heater holder 14.

[0161] In this embodiment, each of the two susceptor assemblies 12 is arranged substantially outside of the internal passage 26 of the tubular heater holder 14, and extends in a plane parallel to a central longitudinal axis of the heater holder 14. The heating region of each susceptor element is arranged entirely outside of the internal passage 26, and each of the mounting regions extends through one of the openings 28 in the side wall of the heater holder.

[0162] The heater holder comprises a base 30 that partially closes one end of the internal passage 26. In this embodiment, the base 30 forms a liquid tight seal with the internal passage 26, such that the internal passage is configured to hold a liquid. The base 30 comprises a plurality of air inlets 32; however, the air inlets 32 are arranged outside of the internal passage 26.

[0163] The heater holder 14 further comprises a pair of piercing elements 34 extending from an inner surface of the side wall, into the internal passage 26, towards the central longitudinal axis of the heater holder 14.

[0164] The cartridge 10 further comprises an outer housing 36 that generally forms a hollow cylinder, defining an internal space in which the susceptor assembly 12 and the heater holder 14 are contained. The outer housing 36 forms a first portion of the cartridge 10, and the susceptor assembly 12 and the heater holder 14 form

a second portion of the cartridge 10. The second portion of the cartridge is slidable relative to the first portion of the cartridge between a storage configuration, as shown in Figure 6a, and a use configuration, as shown in Figure 6b.

[0165] The cartridge 10 has a mouth end defining a mouth end opening 38, and a connection end configured for connection of the cartridge 10 to an aerosol-generating device. The susceptor assembly 12 and the heater holder 14 are located towards the connection end of the cartridge 10. The external width of the outer housing 36 is greater at the mouth end of the cartridge 10 than at the connection end, which are joined by a shoulder 37.

[0166] A liquid reservoir 40 is defined in the cartridge for holding a liquid aerosol-forming substrate 42. The liquid reservoir 44 is located towards the mouth end of the outer housing 36, and comprises a cylindrical space defined by an internal wall of the outer housing 36. A space 46 is located towards the connection end of the outer housing 36, and comprises a cylindrical space defined by the internal passage 26 of the heater holder 14.

[0167] The liquid reservoir 44 and space 46 are fluidly isolated from each other by an aluminium foil seal 52, which is pierceable by the piercing elements 34 of the heater holder to allow liquid aerosol-forming substrate 42 to flow between the first and second portions 44, 46 of the liquid reservoir.

[0168] A first passage 48 is defined between an outer surface of the internal wall defining the liquid reservoir 44, and an inner surface of an external wall of the outer housing 36. The first passage 48 extends between the mouth end opening 38, and the heater holder 14. A second passage 49 is defined between the inner surface of the external wall of the outer housing 36 and the outer surface of the heater holder 14. The base 30 of the tubular heater holder 14 is provided with an annular, ribbed, elastomeric gasket 50 that extends between the outer surface of the tubular susceptor 14 and the internal surface of the external wall of the outer housing 36. The gasket 50 provides an air tight seal between the heater holder 14 and the outer housing 36.

[0169] An air passage is formed through the cartridge 10 by the first and second passages 48, 49. The air passage extends from the air inlets 32 in the base 30 of the heater holder 14, through the second passage 49, and through the first passage 48 to the mouth end opening 38. The air passage enables air to be drawn through the cartridge 10 from the connection end to the mouth end.

[0170] In the storage configuration, as shown in Figure 6a, the base 30 of the heater holder 14 extends out of the outer housing 36, and the piercing elements 34 of the heater holder 14 are spaced from the seal 52 in the direction of the connection end of the cartridge 10. In this configuration, the liquid aerosol-forming substrate 42 is held in the liquid reservoir 44, and is isolated from the space 46 by the seal 52.

[0171] In the use configuration, as shown in Figure 6b, the heater holder 14 and the susceptor assembly 12 are

pushed into the outer housing 36, towards the mouth end. As the heater holder 14 is pushed towards the mouth end of the outer housing 36, the gasket 50 at the base 30 of the heater holder 14 slides over the inner surface of the outer housing 36, maintaining an air tight seal between the inner surface of the outer housing 36 and the outer surface of the tubular heater holder body as the base of the heater holder 14 is received in the outer housing. As the piercing elements 34 of the heater holder 14 are moved towards the mouth end, the piercing elements 34 contact and pierce the seal 52, allowing fluid communication between the liquid reservoir 44, and the space 46. The liquid aerosol-forming substrate 42 in the liquid reservoir 44 is released into the space 44, and the susceptor assembly 12 is exposed to the liquid aerosol-forming substrate 42. In the use configuration, the mounting regions 22 of the susceptor elements, and the corresponding portions of the wicking element that extend into the second portion 46 of the liquid reservoir 40, are able to draw the liquid aerosol-forming substrate 42 from the space 46 to the heating regions 24 of the susceptor elements.

[0172] Figures 7a and 7b show an aerosol-generating system comprising the cartridge 10 of Figures 6a and 6b in the use configuration, received in an aerosol-generating device 60. Figure 7b shows the aerosol-generating system of Figure 7a rotated through 90 degrees about the longitudinal axis of the system. The aerosol-generating device 60 is substantially similar to the aerosol-generating device 60 shown in Figures 1a and 1b, and like features are denoted by like reference numerals.

[0173] The aerosol-generating device 60 comprises a generally cylindrical housing 62 having a connection end and a distal end opposite the connection end. A cavity 64 for receiving the connection end of the cartridge is located at the connection end of the device 60, and an air inlet 65 is provided through the outer housing at the base of the cavity 64 to enable ambient air to be drawn into the cavity 64 at the base. The cavity includes a projection 63 at the base of the cavity that provides a contact surface against which the engagement surface on the base of the cartridge is pressed as the cartridge is inserted into the cavity. This urges the heater assembly into the second position.

[0174] The device 60 further comprises an inductive heating arrangement arranged within the housing 62. The inductive heating arrangement includes two pairs of inductor coils, control circuitry 70 and a power supply 72. Only one pair of inductor coils 90, 91 is visible in Figure 7b. The power supply 72 comprises a rechargeable nickel cadmium battery, that is rechargeable via an electrical connector (not shown) at the distal end of the device. The control circuitry 70 is connected to the power supply 72, and to the inductor coil 90, such that the control circuitry 70 controls the supply of power to the inductor coil 90. The control circuitry 70 is configured to supply an alternating current to the inductor coil 90.

[0175] The inductor coils comprise a pair of opposing

planar inductor coils positioned around each susceptor assembly 12 when the cartridge 10 is received in the cavity 64. The inductor coils have a size a shape matching the size and shape of the heating regions of the susceptor elements.

[0176] The inductor coils 90, 91 are configured such that when the alternating current is supplied to the inductor coils, the inductor coils generate opposing alternating magnetic fields on opposite sides of the susceptor assemblies 12. The alternating magnetic fields generated by the inductor coils are directed substantially perpendicular to the plane of the susceptor assemblies 12, and the susceptor elements. As an alternative a single helical coil positioned around the cavity could be used instead.

[0177] In operation, when a user puffs on the mouth end opening 38 of the cartridge 10, ambient air is drawn into the base of the cavity 64 through air inlet 65, and into the base of the cavity 64 through air inlets 32 in the base 30 of the cartridge 10, as shown by the arrows in Figure 7a. The ambient air flows through the cartridge 10 from the base 30 to the mouth end opening 38, through the air passage, and over the susceptor assemblies 12.

[0178] The control circuitry 70 controls the supply of electrical power from the power supply 72 to the inductor coils 90, 91 when the system is activated. The control circuitry 72 may include an airflow sensor (not shown), and the control circuitry 72 may supply electrical power to the inductor coil 66 when user puffs on the cartridge 10 are detected by the airflow sensor.

[0179] When the system is activated, an alternating current is established in the inductor coils 90, 91, which generates alternating magnetic fields in the cavity 64 that penetrate the susceptor assembly 12, causing the heating regions of the susceptor elements to heat. Liquid aerosol-forming substrate in the space 46 is drawn into the susceptor assemblies 12 through the wicking elements to the heating regions of the susceptor elements. The liquid aerosol-forming substrate at the heating regions of the susceptor elements is heated, and volatile compounds from the heated aerosol-forming substrate are released into the air passage of the cartridge 10, which cool to form an aerosol. The aerosol is entrained in the air being drawn through the air passage of the cartridge 10, and is drawn out of the cartridge 10 at the mouth end opening 38 for inhalation by the user.

[0180] Figures 8a and 8b show an aerosol-generating system of another embodiment, using resistive heating rather than inductive heating. Figure 8b shows the aerosol-generating system of Figure 8a rotated through 90 degrees about the longitudinal axis of the system. The aerosol-generating device 100 is similar to the aerosol-generating device 60 shown in Figures 1a and 1b, and like features are denoted by like reference numerals. However, in place of inductor coils a pair of electrical contacts 110 are provided in the cavity 64. The electrical contacts 110 also provide a contact surface that urges the heater assembly of the cartridge into a second position, as described below with reference to Figure 9c. The

electrical contacts provide electrical power to the cartridge 120 from the power supply 72, under the control of control circuitry 70

[0181] The cartridge 120 of the embodiment of Figures 8a and 8b is shown in separately in Figures 9a, 9b and 9c. Figure 9a shows the cartridge with the heater assembly in a first position, prior to use. Figure 9b shows the cartridge rotated by 90 degrees about a central longitudinal axis of the cartridge. Figure 9c shows the cartridge in a use configuration, where the heater assembly has moved to the second position.

[0182] The cartridge 120 of Figures 9a, 9b and 9c is identical to the cartridge 10 of Figure 2a, 2b and 2c except that instead of an inductively heated susceptor assembly, a resistively heated heating element 112 is provided in the heater holder. The heating element 112 comprises a stainless steel mesh and a wicking element. A pair of electrical connectors 113 are provided, one on each side of the heating element and extending through the base 30 to allow for connection with the electrical contacts 110 in the device 100. In all other respects, and notably the arrangement for penetrating the liquid reservoir, the cartridge is the same as the cartridge 10 shown in Figures 2a, 2b and 2c. As the cartridge is inserted into the cavity of the device 100, the electrical connectors 113 engage the contacts 100. As the cartridge housing is pushed further in the distal direction, the heater assembly is pushed to the second position within the cartridge housing as, shown in Figure 9c. In this position, the liquid reservoir has been penetrated and the liquid is transferred to the heating element. The electrical connectors 113 are in contact with electrical contacts 110 and electrical current can be supplied to the heating element under the control of the control circuitry.

Claims

1. A cartridge (10) for an aerosol-generating system, comprising:

a housing (36) containing a sealed liquid reservoir (44);
 a heater assembly (14) within the housing (36), the heater assembly (14) comprising a heating element (12) and a piercing element (34), and wherein the heater assembly (14) is movable relative to the housing (36) from a first position in which the piercing element (34) is outside the sealed liquid reservoir (44) to a second position in which the piercing element penetrates (34) the liquid reservoir (44), wherein the heater assembly (14) comprises a sealing surface that forms a liquid tight seal with the housing (36) or the liquid reservoir (44) when the heater assembly (14) is in the second position and wherein the heating element (12) comprises a susceptor element (16, 18) that is configured to be induc-

tively heated.

2. A cartridge (10) according to claim 1, wherein the heater assembly (14) comprises a wicking material (20) for conveying liquid to a heating surface of the heating element (12).
3. A cartridge (10) according to claim 2, wherein the heating element comprises at least a portion of the wicking material (20).
4. A cartridge (10) according to any preceding claim, wherein the piercing element (34) is hollow.
5. A cartridge (10) according to any one of the preceding claims, wherein the heater assembly (14) comprises gasket (50), and wherein the sealing surface is provided by the gasket (50).
6. A cartridge (10) according to claim 5, wherein the gasket (50) comprises a plurality of sealing ribs, each rib providing a seal with the outer housing (36).
7. A cartridge (10) according to any one of the preceding claims, wherein the heater assembly (14) comprises an engagement surface facing away from the reservoir (44) and accessible from an exterior the cartridge (10).
8. A cartridge (10) according to any preceding claim, comprising a mouth end configured to be placed in a user's mouth and a connection end opposite the mouth end, wherein the heater assembly in the first position is positioned at the connection end and moves closer to the mouth end to reach the second position.
9. A cartridge (10) according to any one of the preceding claims, wherein the liquid reservoir (44) comprises sealing foil and wherein in the second position the piercing element penetrates the sealing foil.
10. A cartridge (10) according to any one of the preceding claims, comprising an airflow channel through the cartridge (10), extending from an air inlet (32), past the heating element (12) to an air outlet when the heater assembly is in the second position.
11. A cartridge (10) according to claim 10, wherein the liquid reservoir (44) surrounds a portion of the airflow channel.
12. An aerosol generating system comprising a cartridge (10) according to any one of the preceding claims and a reusable device that is configured to couple to the cartridge (10), wherein the reusable device comprises a power supply (72) for providing energy to the heating element (12).

13. An aerosol generating system according to claim 12, wherein the reusable device comprises a contact surface that engages an engagement surface on the heating assembly (14) when the cartridge (10) is coupled to the reusable device to urge the heater assembly (14) into the second position, so that the heater assembly (14) is moved from the first position to the second position as a consequence of the cartridge (10) being coupled to the reusable device, the engagement surface on the heating assembly (14) facing away from the reservoir (44).
14. An aerosol generating system according to claim 12 or 13, wherein the reusable portion comprises one or more inductor coils (66, 68) configured to generate a variable magnetic flux through the heating element (12).

Patentansprüche

1. Patrone (10) zum Gebrauch in einem Aerosolerzeugungssystem, umfassend:
- ein Gehäuse (36), das einen abgedichteten Flüssigkeitsvorratsbehälter (44) enthält; eine Heizvorrichtungsbaugruppe (14) innerhalb des Gehäuses (36), wobei die Heizvorrichtung (14) ein Heizelement (12) und ein Durchstechelement (34) umfasst, und die Heizvorrichtung (14) relativ zu dem Gehäuse (36) aus einer ersten Position, in der sich das Durchstechelement (34) außerhalb des abgedichteten Flüssigkeitsvorratsbehälters (44) befindet, in eine zweite Position beweglich ist, in der das Durchstechelement (34) in den Flüssigkeitsvorratsbehälter (44) eindringt, wobei die Heizvorrichtungsbaugruppe (14) eine Dichtungsfläche aufweist, die eine flüssigkeitsdichte Dichtung mit dem Gehäuse (36) oder dem Flüssigkeitsvorratsbehälter (44) bildet, wenn sich die Heizvorrichtungsbaugruppe (14) in der zweiten Position befindet, und wobei das Heizelement (12) ein Suszeptorelement (16, 18) umfasst, das zum induktiven Erwärmen ausgelegt ist.
2. Patrone (10) nach Anspruch 1, wobei die Heizvorrichtungsbaugruppe (14) ein Dochtmaterial (20) zum Transportieren von Flüssigkeit zu einer Heizfläche des Heizelements (12) umfasst.
3. Patrone (10) nach Anspruch 2, wobei das Heizelements wenigstens einen Abschnitt des Dochtmaterials (20) umfasst.
4. Patrone (10) nach einem beliebigen vorhergehenden Anspruch, wobei das Durchstechelement (34) hohl ist.
5. Patrone (10) nach einem beliebigen der vorhergehenden Ansprüche, wobei die Heizvorrichtungsbaugruppe (14) eine Dichtung (50) umfasst, und wobei die Dichtungsfläche durch die Dichtung (50) vorgesehen ist.
6. Patrone (10) nach Anspruch 5, wobei die Dichtung (50) eine Vielzahl von Dichtungsrippen umfasst, wobei jede Rippe eine Dichtung mit dem Außenmantel (36) vorsieht.
7. Patrone (10) nach einem beliebigen der vorhergehenden Ansprüche, wobei die Heizvorrichtungsbaugruppe (14) eine von dem Vorratsbehälter (44) abgewandte Eingriffsfläche aufweist, die von außerhalb der Patrone (10) zugänglich ist.
8. Patrone (10) nach einem beliebigen vorhergehenden Anspruch, umfassend ein zum Platzieren in dem Mund eines Benutzers ausgelegtes Mundende und ein dem Mundende gegenüberliegendes Verbindungsende, wobei die Heizvorrichtungsbaugruppe in der ersten Position an dem Verbindungsende positioniert ist und sich näher an das Mundende bewegt, um die zweite Position zu erreichen.
9. Patrone (10) nach einem beliebigen der vorhergehenden Ansprüche, wobei der Flüssigkeitsvorratsbehälter (44) eine Dichtungsfolie umfasst und wobei das Durchstechelement in der zweiten Position die Dichtungsfolie durchsticht.
10. Patrone (10) nach einem beliebigen der vorhergehenden Ansprüche, umfassend einen Luftstromkanal durch die Patrone (10), der sich von einem Lufteinlass (32) an dem Heizelement (12) vorbei zu einem Luftauslass erstreckt, wenn sich die Heizvorrichtungsbaugruppe in der zweiten Position befindet.
11. Patrone (10) nach Anspruch 10, wobei der Flüssigkeitsvorratsbehälter (44) einen Abschnitt des Luftstromkanals umgibt.
12. Aerosolerzeugungssystem, umfassend eine Patrone (10) nach einem der vorhergehenden Ansprüche und eine wiederverwendbare Vorrichtung, die zum Koppeln mit der Patrone (10) ausgelegt ist, wobei die wiederverwendbare Vorrichtung eine Energieversorgung (72) zur Bereitstellung von Energie an das Heizelement (12) aufweist.
13. Aerosolerzeugungssystem nach Anspruch 12, wobei die wiederverwendbare Vorrichtung eine Kontaktfläche aufweist, die mit einer Eingriffsfläche an der Heizvorrichtungsbaugruppe (14) in Eingriff kommt, wenn die Patrone (10) mit der wiederverwendbaren Vorrichtung gekoppelt ist, um die Heizvorrichtungsbaugruppe (14) in die zweite Position zu drängen,

sodass die Heizvorrichtungsbaugruppe (14) als Folge des Koppelns der Patrone (10) mit der wiederverwendbaren Vorrichtung von der ersten Position in die zweite Position bewegt wird, wobei die Eingriffsfläche an der Heizvorrichtungsbaugruppe (14) von dem Vorratsbehälter (44) abgewandt ist.

14. Aerosolerzeugungssystem nach Anspruch 12 oder 13, wobei der wiederverwendbare Abschnitt eine oder mehrere Induktorspulen (66, 68) aufweist, die zum Erzeugen eines variablen Magnetflusses durch das Heizelement (12) ausgelegt sind.

Revendications

1. Cartouche (10) pour un système de génération d'aérosol, comprenant :

un logement (36) contenant un réservoir de liquide scellé (44) ;

un ensemble de chauffage (14) au sein du logement (36), l'ensemble de chauffage (14) comprenant un élément de chauffage (12) et un élément de perçage (34), et dans laquelle l'ensemble de chauffage (14) est mobile par rapport au logement (36) depuis une première position dans laquelle l'élément de perçage (34) est en dehors du réservoir de liquide scellé (44) vers une deuxième position dans laquelle l'élément de perçage pénètre (34) le réservoir de liquide (44), dans laquelle l'ensemble de chauffage (14) comprend une surface de scellement qui forme un scellement étanche aux liquides avec le logement (36) ou le réservoir de liquide (44) lorsque l'ensemble de chauffage (14) est dans la deuxième position et dans laquelle l'élément de chauffage (12) comprend un élément susceptible (16, 18) qui est configuré pour être chauffé par induction.

2. Cartouche (10) selon la revendication 1, dans laquelle l'ensemble de chauffage (14) comprend un matériau à effet de mèche (20) pour acheminer un liquide vers une surface de chauffage de l'élément de chauffage (12).

3. Cartouche (10) selon la revendication 2, dans laquelle l'élément de chauffage comprend au moins une portion du matériau à effet de mèche (20).

4. Cartouche (10) selon l'une quelconque des revendications précédentes, dans laquelle l'élément de perçage (34) est creux.

5. Cartouche (10) selon l'une quelconque des revendications précédentes, dans laquelle l'ensemble de chauffage (14) comprend un joint (50), et dans la-

quelle la surface de scellement est fournie par le joint (50).

6. Cartouche (10) selon la revendication 5, dans laquelle le joint (50) comprend une pluralité de nervures de scellement, chaque nervure fournissant un scellement avec le logement extérieur (36).

7. Cartouche (10) selon l'une quelconque des revendications précédentes, dans laquelle l'ensemble de chauffage (14) comprend une surface de mise en prise tournée à l'opposé du réservoir (44) et accessible depuis l'extérieur de la cartouche (10).

8. Cartouche (10) selon l'une quelconque des revendications précédentes, comprenant une extrémité buccale configurée pour être placée dans la bouche d'un utilisateur et une extrémité de raccordement opposée à l'extrémité buccale, dans laquelle l'ensemble de chauffage dans la première position est positionné au niveau de l'extrémité de raccordement et se rapproche de l'extrémité buccale pour atteindre la deuxième position.

9. Cartouche (10) selon l'une quelconque des revendications précédentes, dans laquelle le réservoir de liquide (44) comprend un opercule de scellement et dans laquelle, dans la deuxième position, l'élément de perçage pénètre dans l'opercule de scellement.

10. Cartouche (10) selon l'une quelconque des revendications précédentes, comprenant un canal d'écoulement d'air à travers la cartouche (10), s'étendant depuis une entrée d'air (32), au-delà de l'élément de chauffage (12) jusqu'à une sortie d'air lorsque l'ensemble de chauffage est dans la deuxième position.

11. Cartouche (10) selon la revendication 10, dans laquelle le réservoir de liquide (44) entoure une portion du canal d'écoulement d'air.

12. Système de génération d'aérosol comprenant une cartouche (10) selon l'une quelconque des revendications précédentes et un dispositif réutilisable qui est configuré pour se coupler à la cartouche (10), dans lequel le dispositif réutilisable comprend une alimentation électrique (72) pour fournir de l'énergie à l'élément de chauffage (12).

13. Système de génération d'aérosol selon la revendication 12, dans lequel le dispositif réutilisable comprend une surface de contact qui met en prise une surface de mise en prise sur l'ensemble de chauffage (14) lorsque la cartouche (10) est couplée au dispositif réutilisable pour pousser l'ensemble de chauffage (14) dans la deuxième position, de sorte que l'ensemble de chauffage (14) est déplacé de la première position à la deuxième position en conséquen-

ce du couplage de la cartouche (10) au dispositif réutilisable, la surface de mise en prise sur l'ensemble de chauffage (14) étant tournée à l'opposé du réservoir (44).

5

- 14.** Système de génération d'aérosol selon la revendication 12 ou 13, dans lequel la portion réutilisable comprend une ou plusieurs bobines d'induction (66, 68) configurées pour générer un flux magnétique variable à travers l'élément de chauffage (12).

10

15

20

25

30

35

40

45

50

55

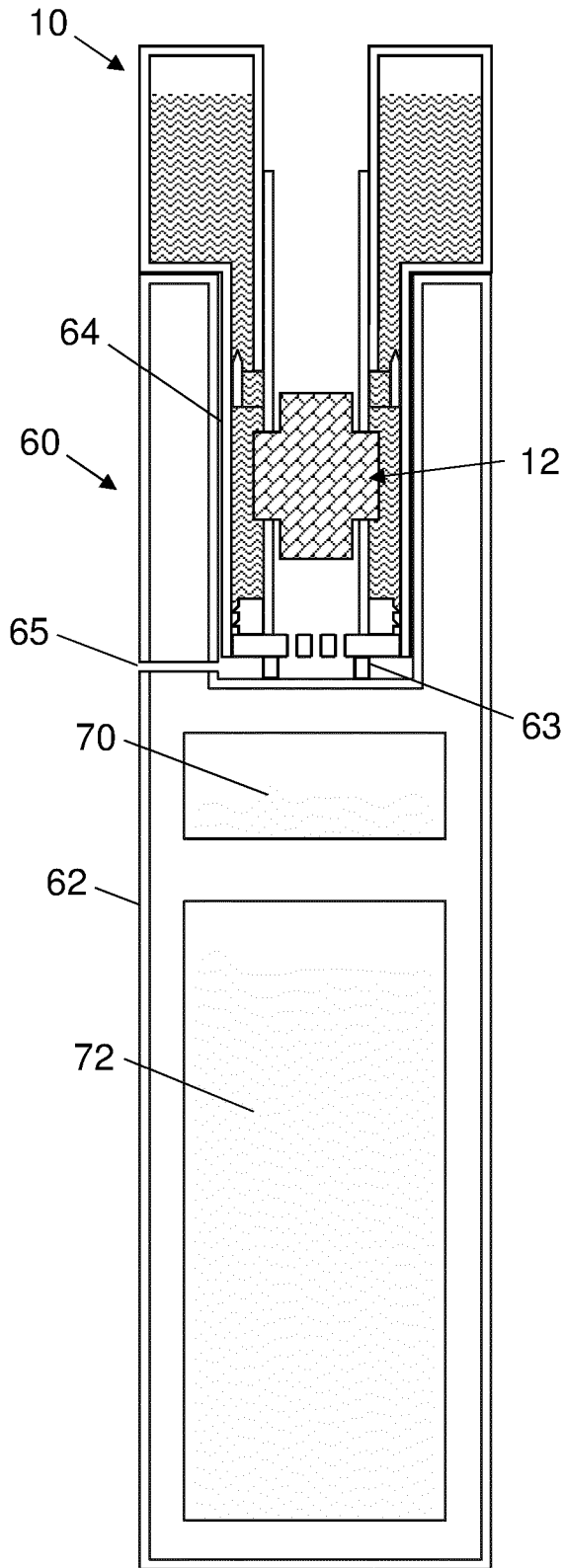

Figure 1a

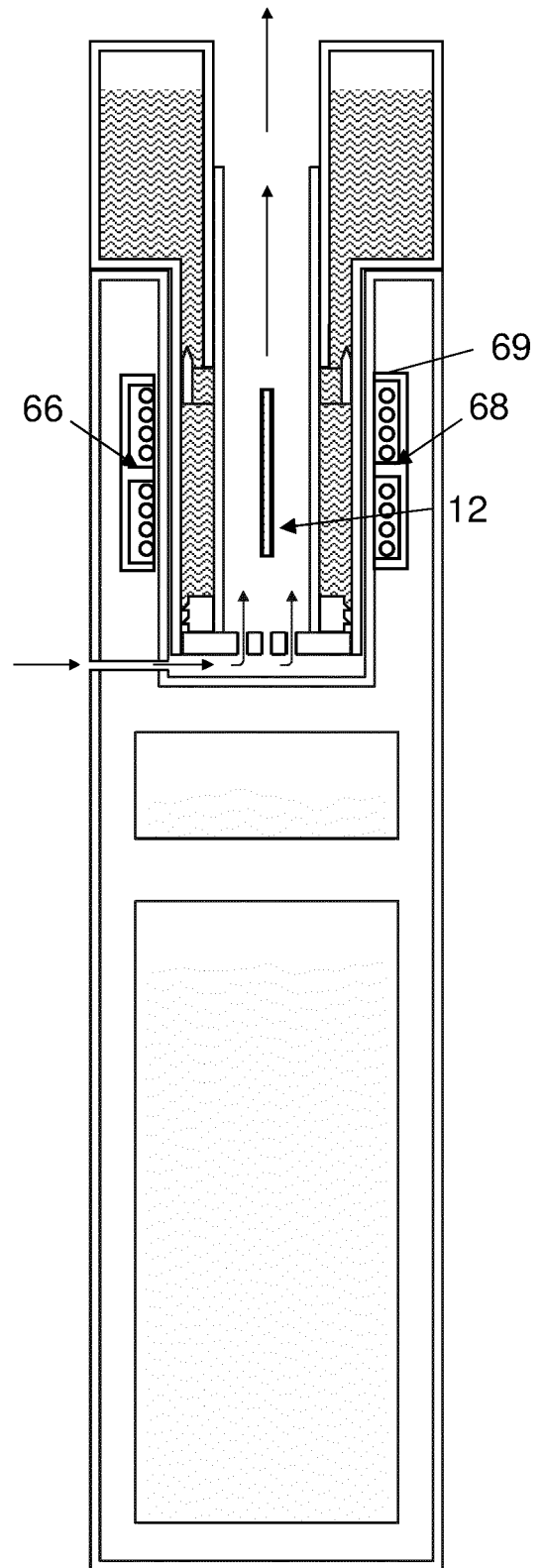

Figure 1b

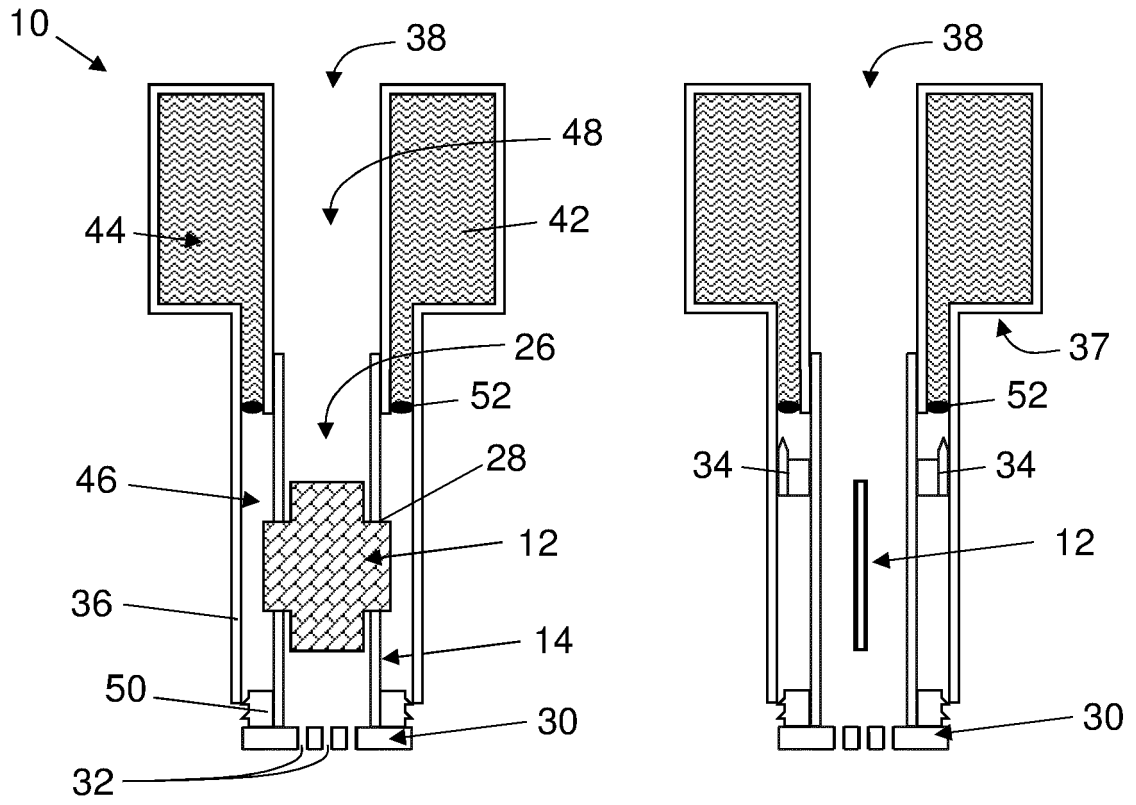

Figure 2a

Figure 2b

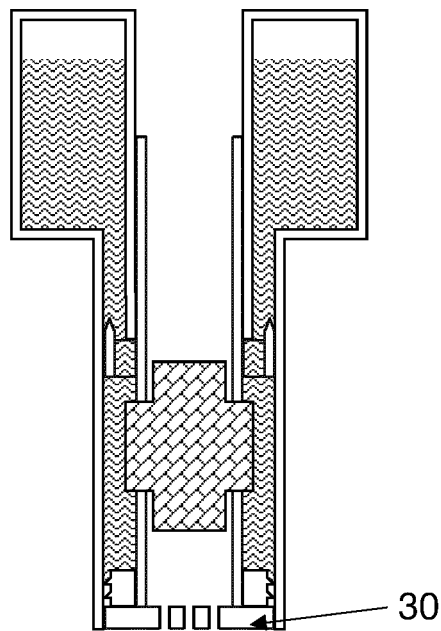

Figure 2c

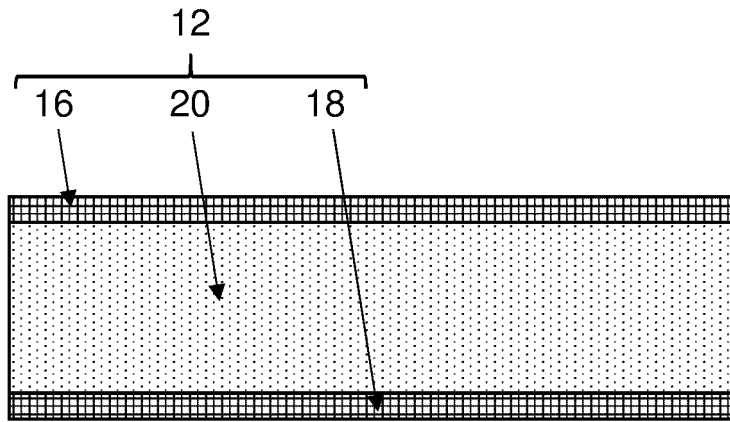

Figure 3a

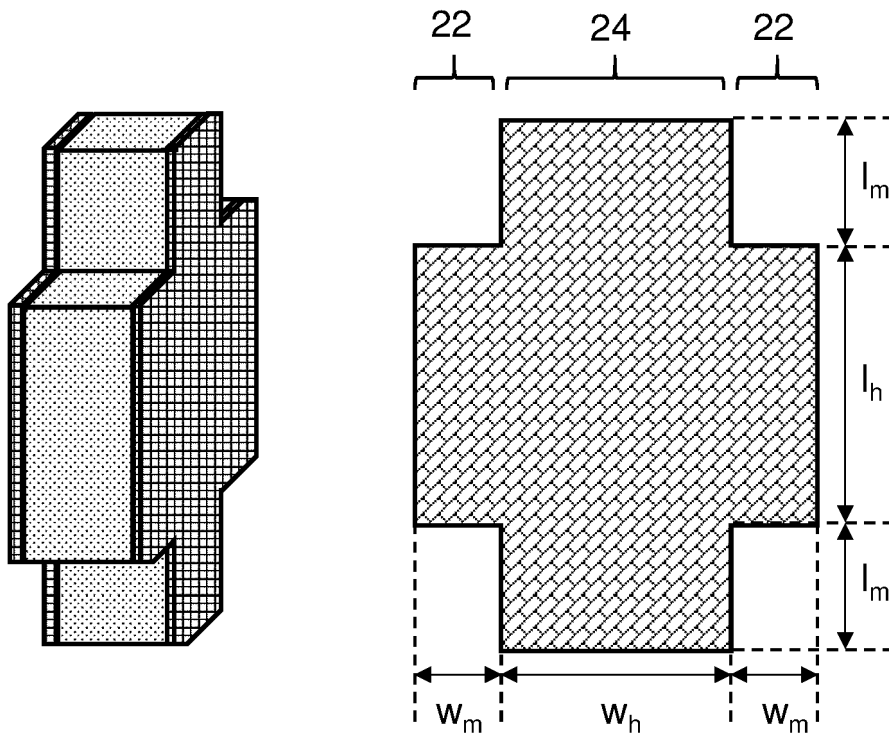

Figure 3b

Figure 3c

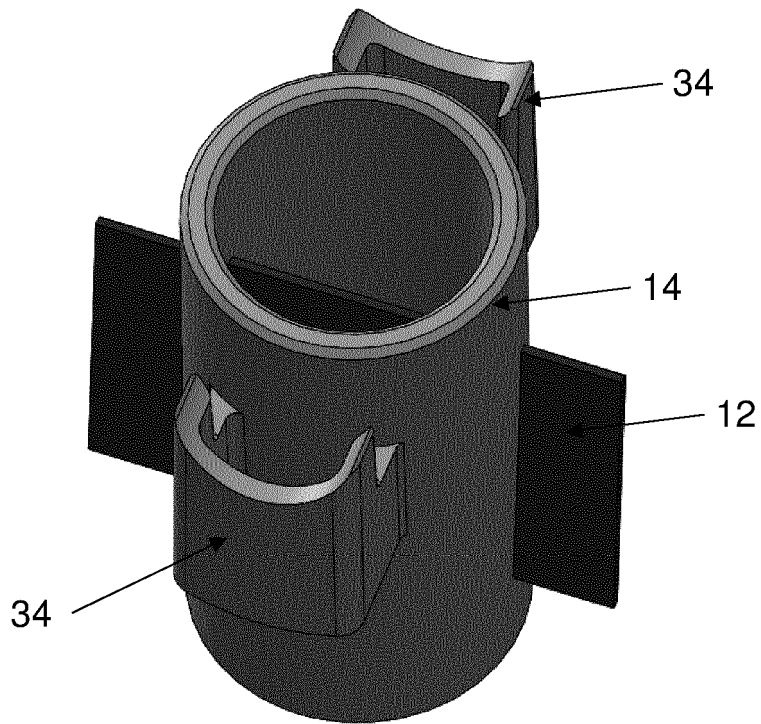

Figure 4a

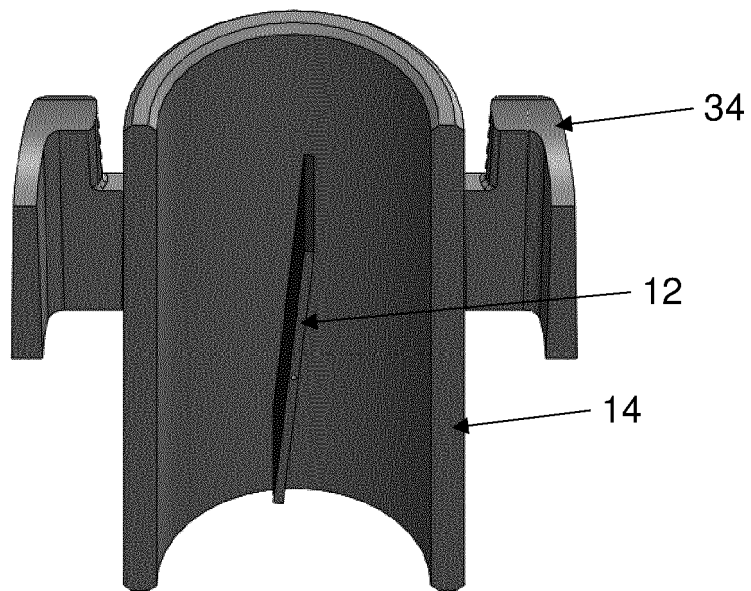

Figure 4b

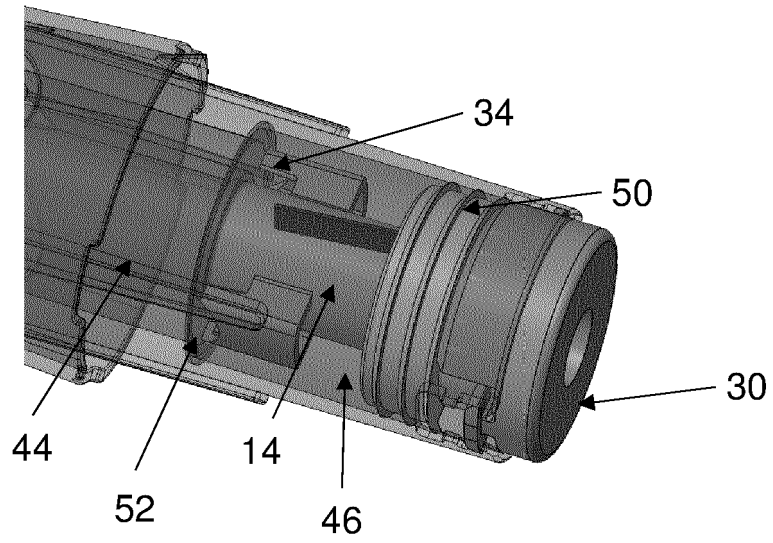

Figure 5a

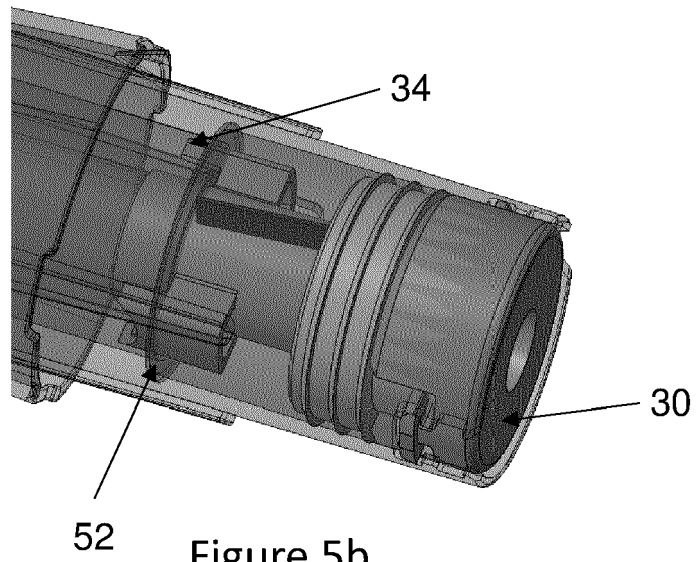

Figure 5b

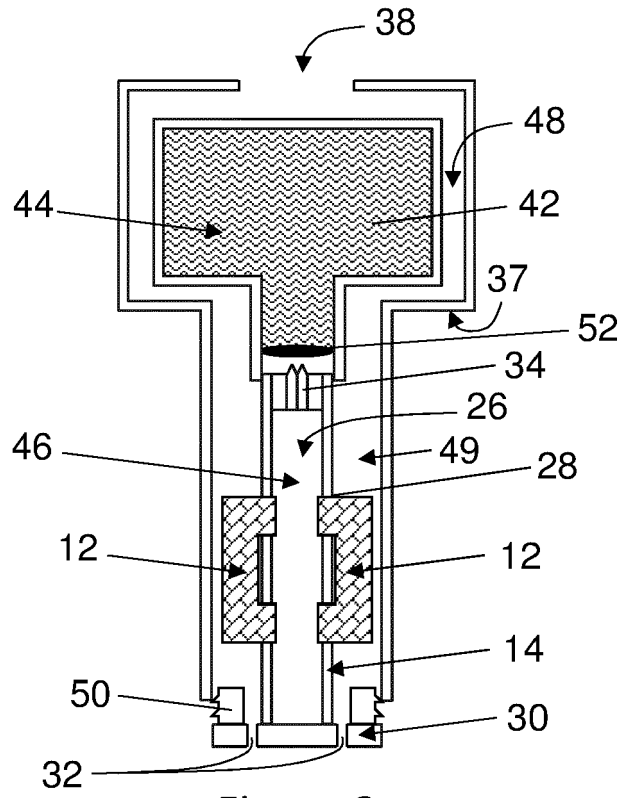

Figure 6a

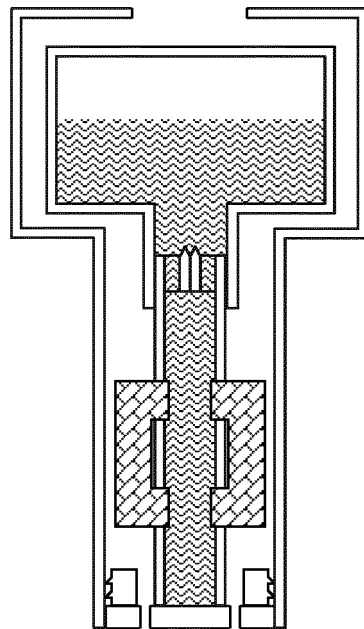

Figure 6b

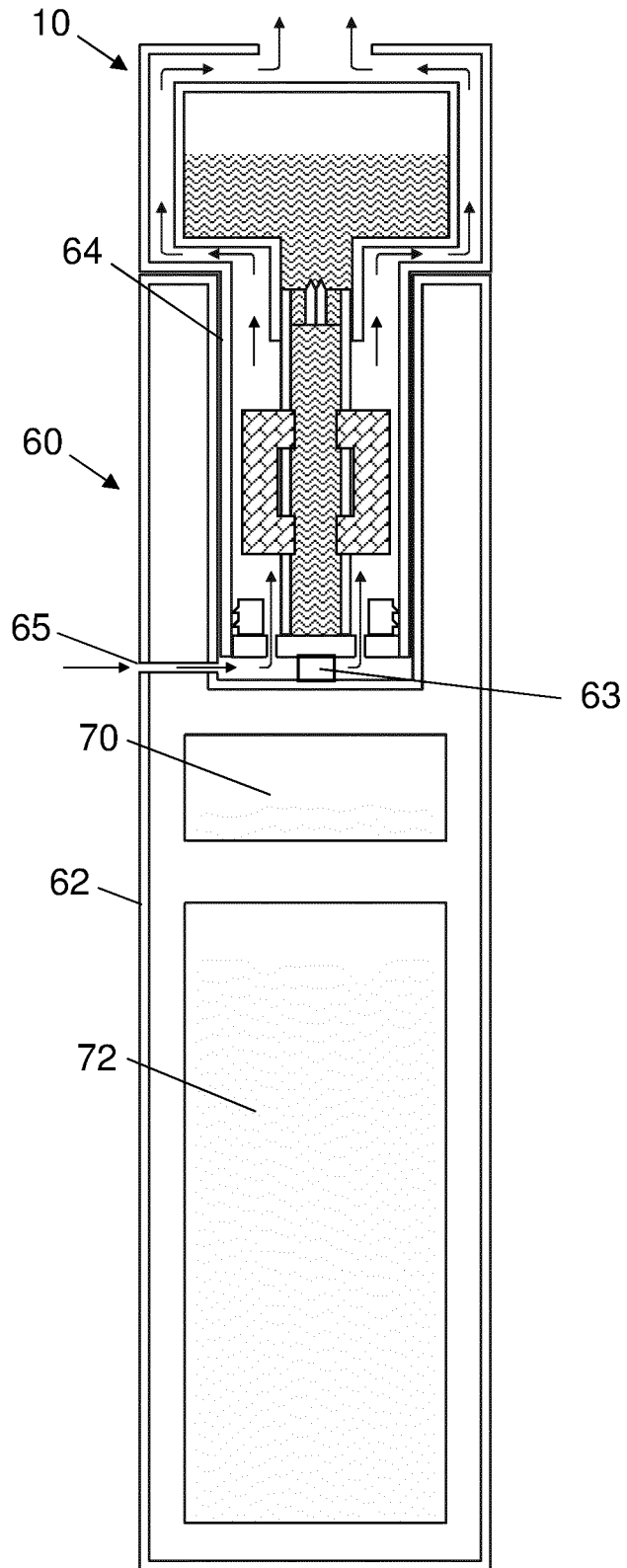

Figure 7a

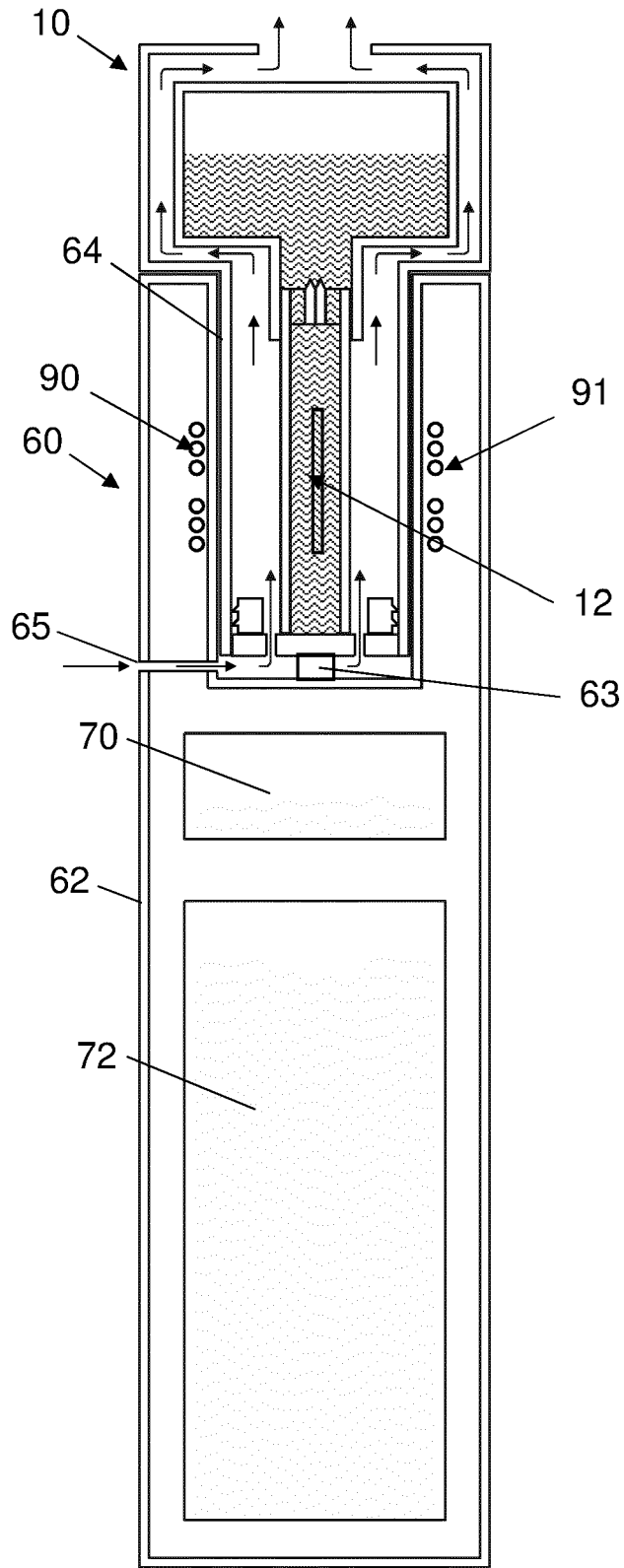

Figure 7b

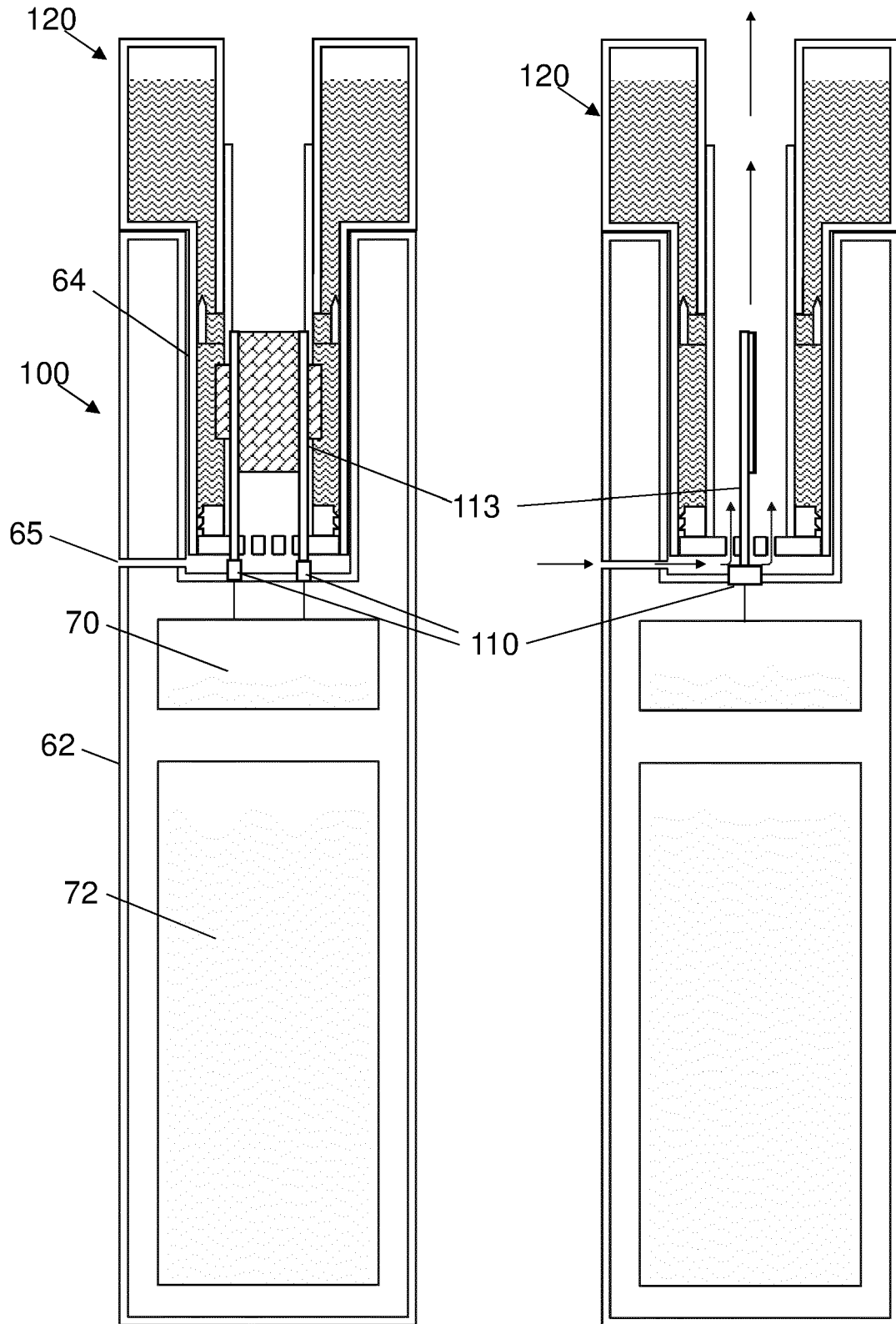

Figure 8a

Figure 8b

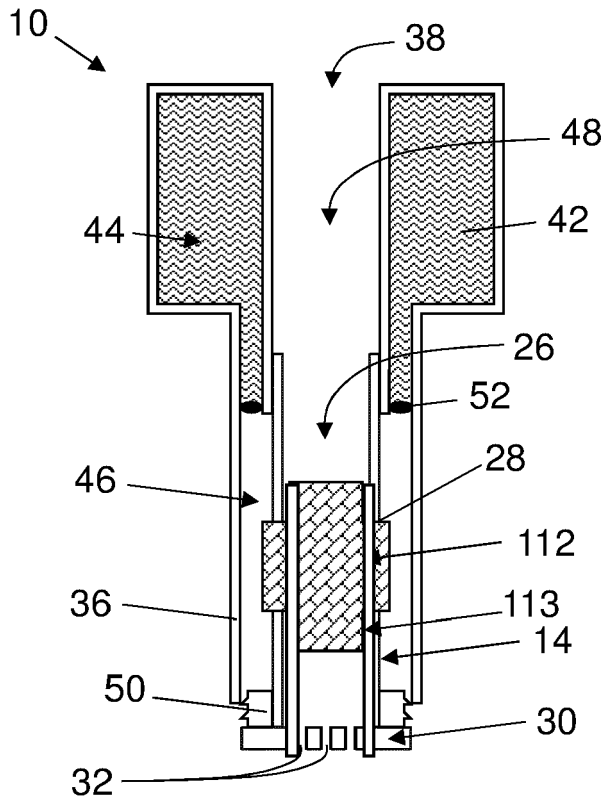

Figure 9a

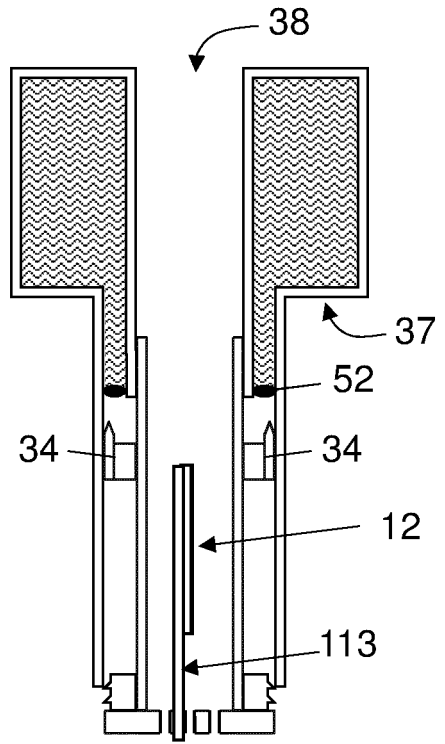

Figure 9b

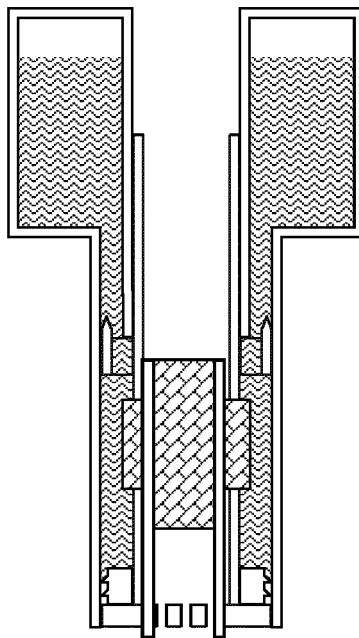

Figure 9c

REFERENCES CITED IN THE DESCRIPTION

This list of references cited by the applicant is for the reader's convenience only. It does not form part of the European patent document. Even though great care has been taken in compiling the references, errors or omissions cannot be excluded and the EPO disclaims all liability in this regard.

Patent documents cited in the description

- WO 2013159245 A1 [0005]